



This is a digital copy of a book that was preserved for generations on library shelves before it was carefully scanned by Google as part of a project to make the world's books discoverable online.

It has survived long enough for the copyright to expire and the book to enter the public domain. A public domain book is one that was never subject to copyright or whose legal copyright term has expired. Whether a book is in the public domain may vary country to country. Public domain books are our gateways to the past, representing a wealth of history, culture and knowledge that's often difficult to discover.

Marks, notations and other marginalia present in the original volume will appear in this file - a reminder of this book's long journey from the publisher to a library and finally to you.

Usage guidelines

Google is proud to partner with libraries to digitize public domain materials and make them widely accessible. Public domain books belong to the public and we are merely their custodians. Nevertheless, this work is expensive, so in order to keep providing this resource, we have taken steps to prevent abuse by commercial parties, including placing technical restrictions on automated querying.

We also ask that you:

- + *Make non-commercial use of the files* We designed Google Book Search for use by individuals, and we request that you use these files for personal, non-commercial purposes.
- + *Refrain from automated querying* Do not send automated queries of any sort to Google's system: If you are conducting research on machine translation, optical character recognition or other areas where access to a large amount of text is helpful, please contact us. We encourage the use of public domain materials for these purposes and may be able to help.
- + *Maintain attribution* The Google "watermark" you see on each file is essential for informing people about this project and helping them find additional materials through Google Book Search. Please do not remove it.
- + *Keep it legal* Whatever your use, remember that you are responsible for ensuring that what you are doing is legal. Do not assume that just because we believe a book is in the public domain for users in the United States, that the work is also in the public domain for users in other countries. Whether a book is still in copyright varies from country to country, and we can't offer guidance on whether any specific use of any specific book is allowed. Please do not assume that a book's appearance in Google Book Search means it can be used in any manner anywhere in the world. Copyright infringement liability can be quite severe.

About Google Book Search

Google's mission is to organize the world's information and to make it universally accessible and useful. Google Book Search helps readers discover the world's books while helping authors and publishers reach new audiences. You can search through the full text of this book on the web at <http://books.google.com/>



Eng 4249.21.9



HARVARD
COLLEGE
LIBRARY



PRINCIPLES
OF
RADIO COMMUNICATION

BY

J. H. MORECROFT

*Associate Professor of Electrical Engineering,
Columbia University*

ASSISTED BY

A. PINTO

Assistant to Chief Electrical Engineer, New York Edison Co.

AND

W. A. CURRY

Instructor in Electrical Engineering, Columbia University

NEW YORK
JOHN WILEY & SONS, Inc.
LONDON: CHAPMAN & HALL, LIMITED
1921

~~TH~~
6550
~~38~~

Eng. 4249.21.9

Dec. 14, 1921
HARVARD UNIVERSITY
ENGINEERING SCHOOL

~~43~~
~~IT~~

~~31~~

HARVARD COLLEGE LIBRARY
TRANSFERRED FROM THE
ENGINEERING SCHOOL
1929

Copyright, 1921
By J. H. MORECROFT

82412
52-100
34

PRINTED BY
BRAUNWORTH & CO.
BOOK MANUFACTURERS
BROOKLYN, N. Y.

PREFACE

THE student desiring to familiarize himself with the theory and practice of Radio Communication should be thoroughly grounded in the ordinary laws of continuous and alternating-current circuits; he should also have a clear physical conception of the transient conditions continually occurring in such circuits. These elementary ideas are best obtained by considering the electric current from the electron view point, i.e., as a comparatively slow drift of innumerable minute negative electric charges, which, at the same time they are drifting through the substance of the conductor, are executing haphazard motions with very high velocities, continually colliding with each other and with the molecules of which the conductor is composed.

Due to the extremely high frequencies encountered in radio practice it is necessary to expand somewhat one's ideas of resistance, inductance, and capacity, the so-called constants of the electric circuit. As a result of the non-uniformity of current distribution the resistance of a conductor at high frequency is generally much higher in a radio circuit than it is at ordinary engineering frequencies; due to non-penetration of magnetic flux and hysteretic lag, the apparent permeability of an iron core is much less at radio frequencies than at the customary sixty cycles; due to imperfect polarization of dielectrics the apparent specific inductive capacity of an insulator may be much decreased at radio frequencies and the heating due to dielectric losses may be thousands of times as great as is the case in ordinary engineering practice. Furthermore, due to the unavoidable internal capacity, the apparent inductance of even an air core coil may be expected to vary at high frequencies; in fact, a piece of apparatus which is physically a coil, when used at radio frequencies, may, by electric measurement, be found a condenser.

All of the effects indicated above are treated in the early chapters of the text, not in as comprehensive manner as is possible, to be sure, but with sufficient thoroughness to open the student's eyes to the possible peculiar behavior of circuits when excited by the very high frequencies of radio practice.

Because of its importance to the radio art a considerable part of the text is given over to the theory and behavior of the thermionic three-

electrode tube; at the time this material was compiled there was no comprehensive treatment of the subject anywhere, but there has recently appeared an excellent volume on Vacuum Tubes (by H. J. Van der Bijl) which every student of radio should carefully peruse. It is hoped that the subject matter presented in this text may supplement, rather than duplicate, that given in the above mentioned volume; the actual behavior of tubes in typical circuits is covered in this text in a more thorough manner than has been attempted in other texts, and practically all the theoretical deductions are substantiated by experimental data, much of which has been obtained in the author's laboratory.

A chapter has been devoted to each important phase of the radio art; there is also incorporated a short course of elementary experiments which may well be carried out by electrical engineering students especially interested in Radio. For those desiring to specialize in Radio, the material given in the body of the text will furnish ideas for unlimited further experimentation.

On certain parts of the text very valuable assistance has been given by the author's former colleague, Mr. A. Pinto, and by Mr. W. A. Curry, who is at present associated with him in radio instruction; due credit is given to them on the title page of the text.

J. H. M.

COLUMBIA UNIVERSITY,
April, 1921.

ERRATA

- Page 20, 13th line from bottom. For 6.38 read 6.28.
- 37, 11th line from bottom. Insert " of current " after " equation ".
- 41, 14th line from bottom should read: sine wave of current is the square root of one-half the (maximum value)².
- 46, 6th line from top. Insert R after I_m .
48. For eq. 22 read: $p = \frac{E_m I_m}{2} \cos \phi (1 - \cos 2\omega t)$.
73. At bottom of page add line: We might keep B fixed and vary the value of the capacity of condenser C_1 .
- 80, next to last line. For L read L_1 .
- 80, last line. For $(L'_c - L'_d) - M'$ read $(L'_c + L'_d) - M'$.
- 86, 9th line. For circuit 2 read circuit 1.
93. In legend of Fig. 91 for eqs. 64 and 65 read eqs. 84 and 85.
- 99, Fig. 97. For frequencies lower than 68 cycles reverse the dashed and full line curves.
- 171, 4th line from bottom. For $1000\mu\mu h$ read $1000\mu h$.
- 208, last equation on page. Insert \sin before $(2\pi 110.5t)$.
- 379, Fig. 13. Negative end of heating battery connects to thimble
- 434, 21st line. Insert μ before E_g .
- 456, second equation. Multiply right-hand side by R .
- 492, Eq. 46. For $2\pi L_1$ read $4\pi L_1$.
- 505, Eq. 77. For $\omega(L_2 - M) - \frac{1}{\omega C_2}$ read $\omega(L_2 - M) - \frac{1}{\omega C_1}$.
- 506, last equation. For b^2 read b .
- 591, 17th line from bottom. For smaller read larger.
733. The right-hand side of eq. 16 is twice as large as it should be (because of incorrect reference to eq. 9). Divide it by the factor 2 as well as the subsequent formulæ and problems depending on it, including eqs. 17, 18, 19, 20, 21, and 22.
- 733, Fig. 46. For $\sin \theta$ read $\cos \theta$.
- 774, 3d line from bottom. For 80 read 79.
- 821, 4th line. For $L_1 \mp 2M + L_2$ read $L_1 \pm 2M + L_2$.
- 822, Fig. 34. Insert ammeter A in a condenser lead instead of where shown.
- 889, 4th and 5th lines. Delete: adjusting the secondary turns so as to give maximum secondary current and.

665, 5th line from bottom, For equation 16 read L_1

CONTENTS

CHAPTER I

FUNDAMENTAL IDEAS AND LAWS

	PAGES
Electrons—Electric fields—Induced charges—Electric current—Conductors and insulators—Continuous and alternating current—Wave shape—Magnetic fields—Units—Induced e.m.f.—Self-induction—Coupling—Capacity—Oscillograph—Current flow in inductive and condensive circuits—Time constant—Alternating-current flow in various circuits—Effect of frequency—Transients in inductive circuits—Resonance—Decrement—Decrement from resonance curve—Parallel circuits—Various types of coupling—Effect of neighboring circuits on resistance and reactance—Resonance in coupled circuits—Resonance in electrically long circuits	1-110

CHAPTER II

RESISTANCE—INDUCTANCE—CAPACITY

General concept of resistance—Various factors affecting resistance—Skin effect and its elimination—Skin effect in coils—Eddy currents in iron cores—Characteristics of iron core coils—Resistance of arc and spark—Resistance of an antenna.	
Coefficient of self-induction—Self-induction of single vertical wire—Single horizontal wire—Single circular turn—Single layer solenoid—Flat spiral—Toroid—Single layer square coil—Flat square coil—Multilayer coil—Mutual induction of two single turns—Coaxial solenoids—Two-wire antenna—Two concentric coils—Two coaxial spirals.	
Capacity in general—Capacity of an isolated sphere—Parallel circular plates—Single vertical wire—Mutual capacity of two horizontal wires—Multiplate condenser—Forms of condensers—Specific inductive capacity—Losses on condensers—Phase difference of a condenser—Internal capacity coils—Natural period of coils	111-178

CHAPTER III

GENERAL VIEW OF RADIO COMMUNICATION

Wave motion in water—Electro-magnetic waves—Velocity of propagation—Different types of waves—Spark telegraphy—Continuous-wave telegraphy—Radio telephony—Receiving station—Selectivity—Interference—Simultaneous sending and receiving—Atmospheric disturbance—Elimi-	
---	--

	PAGES
nation of atmospheric disturbance—Attenuation of waves—Day and night variation in signal strength—Seasonal variation—Amounts of power required—"Freak" transmission	179-201

CHAPTER IV

LAWS OF OSCILLATING CIRCUITS

Condenser discharge through inductance—Effect of condenser leakage—Frequency—Wave-length—Voltage and current relations—Damping and decrement—Decay of current, voltage and energy—Effect of spark gap—Number of waves in a train—Effective value of damped sine wave current—Effect of neighboring circuits upon oscillatory discharge—Coupled pendulums—Oscillations in coupled circuits—Phases and amplitudes of currents—Vector diagram of currents in coupled circuits—Frequency of beats—Quenching gap—Oscillatory circuit excited by continuous voltage—Oscillatory circuit excited by application of alternating voltage—Periodic disturbances in oscillatory circuit—Oscillatory circuit excited by pulse—Impulse excitation of parallel resonant circuit—Oscillatory circuit excited by damped sine wave and resonance curve for such a case	202-274
---	---------

CHAPTER V

SPARK TELEGRAPHY

Normal transmission equipment—Battery and coil—Alternators for radio transmitters—Transformers—Condensers—Resonance conditions in audio frequency circuit—Different types of spark gaps—Oscillation transformer—Energy distribution curves of a transmitter and effect of coupling—Adjustment of a spark transmitter—Elements of a receiving set—Need of a rectifier—Types of coupling—The telephone receiver—Crystal rectifiers—Vacuum tube detector—Adjustment of receiving set—Wave-lengths and ranges of transmission in spark telegraphy—Arrangement of apparatus in typical transmitting stations	275-363
---	---------

CHAPTER VI

VACUUM TUBES AND THEIR OPERATION IN TYPICAL CIRCUITS

Possibility of electron emission—Theoretical prediction of electron evaporation—Electron atmosphere—Power required to produce emission—Two-electrode vacuum tube—Fleming valve—Space charge and its effects—Three-electrode tube—Deforest audion—Potential distribution in three-electrode tube—Uses of three-electrode tube—Operating limits of a tube—Effect of gas—Ionization—Evacuation of a tube—Detection of gas in a tube—Characteristic curves of typical three-electrode tubes—Free grid potential—Equation of plate current—Resistance of tube circuits—Capacity of input circuit—Three-electrode tube as detector—Action of grid condenser—Triode as generator of alternating current power—Output and efficiency—Heating of plates—Phase relations in a triode—Possibility of self-excitation—Triode as detector of continuous	
--	--

wave signals—Analysis of typical circuits used for self-excitation with conditions necessary for oscillation—Starting and stopping oscillations—Parasitic frequencies—Circuits used with triode as detector—Criterion for oscillation in detector tube—Peculiar noises in autodyne circuits—Regenerative circuits for spark signal reception—Triodes in parallel—Alternating-current power supply for plate circuit—Special forms of tubes—Detailed study of triode as power converter—Triode characteristics when used as amplifier.....	364-577
---	---------

CHAPTER VII

CONTINUOUS-WAVE TELEGRAPHY

Advantages of continuous-wave telegraphy—High-frequency generators—Poulsen arc—Elementary theory of oscillating arc—Types of oscillation of arc—Commercial form of arc—High-frequency alternators—Alexanderson alternator—Goldschmidt alternator—Frequency transformers using iron cores—Marconi multiple-gap generator—Methods of signaling used with different generators—Reception of continuous-wave signals—Tone wheel—Heterodyne—Effect of upper harmonics on beat reception—Arrangement of apparatus in continuous-wave tube transmitters.....	578-645
---	---------

CHAPTER VIII

RADIO TELEPHONY

Field of use—The transmitter—The receiver—Modulation—The microphone transmitter—Analysis of modulation—Percentage modulation—Schemes for modulation—The vacuum tube in radio telephony—Heising scheme of modulation and its analysis—Alexanderson scheme of modulation—Analysis of modulated wave—Oscillating tube as receiver—Effect of decrements upon quality of speech—Multiplex radio telephony—Amounts of power used and distances covered—Arrangement of apparatus in a commercial set—Simultaneous transmission and reception.....	646-693
--	---------

CHAPTER IX

ANTENNÆ AND RADIATION

Radiation from simple antenna—Effects of moving electric and magnetic fields—Open and closed electric systems—Fields involved in radiation—Radiated field at a distance from the antenna—Radiation from a coil—Excitation of the transmitting antenna—Various types of antennæ and their characteristics—Relation between simple antenna and coil antenna—Antennæ for air ships—Underwater antennæ—Ground antennæ—Law of radiation from an antenna—Radiation resistance—Current in receiving antenna—Merits of different types of antennæ—Limitation of transmission formulæ—Counterpoises—Antenna resistance—Natural wave-length of an antenna—Current and voltage distribution along an antenna and effect of loading—Direction finders—Reliability of direction finders—Transient effects in an antenna.....	694-780
---	---------

CHAPTER X

WAVEMETERS AND THEIR USE

	PAGES
Frequency and wave-length—Principle of wavemeter—Extending range of a wavemeter—Schemes for indicating resonance—Classification of resonance indicators—Condenser for even scale—Autodyne wavemeter—Measuring the wave-length of a transmitter—Energy distribution—Decrement determination with spark transmitter—Determination of decrement of wavemeter—Decremeter—Measurement of constants of an antenna—Mutual induction and coefficient of coupling determination—An improvised wave-meter.....	781-823

CHAPTER XI

AMPLIFIERS

Amplifiers in general—Characteristics of triodes—Effect of plate circuit resistance and reactance—Classification of amplifiers—Transformer-repeating amplifiers—Construction of transformers for audio-frequency—Impedance of telephone receivers—Connections of transformer-repeating amplifier—Transformer-repeating amplifiers for high frequencies—Resistance amplifier—Proper resistances for repeating—Grid condenser and leak—Inductance-repeating amplifier—Filters and their characteristics—Stability of amplifiers—Tube noises—Arrangement of apparatus in amplifiers.....	824-879
---	---------

CHAPTER XII

RADIO EXPERIMENTS

Resonance curves—Buzzer-generator and crystal detector characteristics—Study and use of wavemeter—Setting up and adjusting a spark transmitter—Measurement of antenna constants—Continuous current characteristics of three-electrode tube—Three-electrode tube as detector of damped waves—Determination of tube constants—Triode as power converter—Triode as source of power in self-exciting circuit—Resistance measurements at high frequency—Oscillating triode as receiver of continuous-wave signals—Study of the audio-frequency amplifier—Study of radio-telephone set.....	880-919
---	---------

PRINCIPLES

OF

RADIO COMMUNICATION

CHAPTER I

FUNDAMENTAL IDEAS AND LAWS

Nature of Electricity.—Everyone is more or less familiar with elementary experiments having to do with electrically charged bodies. Fur, if rubbed on a dry day, crackles and gives off minute sparks; a glass rod rubbed with a cloth becomes electrified and will attract small bits of paper, cotton, etc.; due to wind friction, and other causes, clouds become intensely electrified and are able to break down the insulating strength of the air and produce sparks thousands of feet long.

In what way does an electrified body, or electrically charged body, differ from one in the uncharged, or neutral, state? A reasonable answer to this question is found in the modern conception of the constitution of matter.

Electrons.—It has been firmly established that every atom of matter is charged with minute particles¹ of negative electricity, so-called *electrons*. An electron, when detached from the atom of matter with which it was associated, shows none of the properties of ordinary matter. It does not react chemically with other electrons to produce some new substance; moreover, all electrons are similar, no matter from what type of atom they have been extracted. Thus an electron from the hydrogen atom acts precisely the same as the electrons from atoms of oxygen, iron, chlorine, or any other substance. It seems that the *electron is nothing but electricity*.

¹ It may seem difficult at first to think of electricity as made up of separate, discrete, quantities instead of a continuous distribution of electric charge, but it is pointed out that according to modern concept *energy itself* is always present as a certain number of *unit quantities*; that is, energy itself is to be "counted" in terms of the smallest possible quantity, called a "quantum."

It is definite in amount, always being exactly the same, and is generally believed to be the smallest possible quantity of electricity, i.e., electricity cannot be subdivided into quantities smaller than the electron.

The constants of the electron are: Radius = 2×10^{-13} cm.; mass = 8.8×10^{-28} grams; charge = 1.59×10^{-19} coulomb.¹ The mass of the electron depends upon the velocity with which it is moving; the value given here holds good only if the electron is traveling at velocities considerably less than the velocity of light, say less than 10^9 cm./sec.

For many years it has been the custom for physicists to speak of positive electricity and negative electricity; from this standpoint the electron is negative electricity. All electrons are the same kind, or polarity, hence it follows that *the electron is the smallest possible quantity of negative electricity.*

Charged Body.—From the electron viewpoint a negatively charged body is one having more than its normal number of electrons and a positively charged body is one having less than its normal number of electrons.

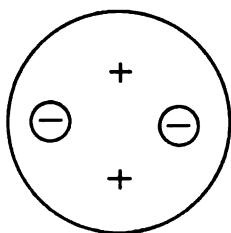

FIG. 1. — Conventional model of a simple, neutral, atom.

Let the circular shape in Fig. 1 represent an atom of hydrogen;² the small circles with the minus sign in them represent the electrons associated with the normal hydrogen atom. The normal atom is not charged; it does not exert any attractive or repulsive force on the other atoms, due to its electrical state.

The structure of the atom itself, whatever it may be, is always charged electrically positive; in the normal atom there are enough electrons to just neutralize the positive charge of the atom itself.

The normal atom acts like an uncharged body, therefore, not because it has no electrical charge associated with it, but because it has just as much negative charge as it has positive charge, and these two charges neutralize one another in so far as action of the atom on other bodies is concerned.

If one electron is removed from the atom by some means or other (represented in Fig. 2) the balance between positive and negative charge is destroyed; an excess of positive charge exists on the atom and the atom is positively charged. The electron which has been removed from the atom constitutes a negative charge. If the electron is allowed to go back

¹The student who is particularly interested in the theoretical and experimental work from which these values are obtained is referred to "Conduction of Electricity through Gases," by J. J. Thomson.

²In recent years much work has been done in investigation of the structure of the atom; an interesting and elementary exposition of some of the modern views is given in "The Nature of Matter and Electricity," by Comstock and Troland.

to the atom the balance of charge is restored and the atom is again uncharged, or neutral.

A positively charged body, therefore, is one which has been deprived of some of its normal number of electrons; a negatively charged body is one which has acquired more than its normal number of electrons. Thus when a piece of sealing wax is rubbed with dry flannel the wax becomes negatively charged and the flannel becomes positively charged. The friction between the wax and the flannel must have rubbed some of the electrons off the flannel molecules and left them on the surface of the wax.

The extra electrons on the wax are attracted by the deficient molecules of the flannel (positive and negative charges attract each other) and if the flannel and wax are left together after being rubbed they soon lose their charges; the molecules of the flannel regain their proper number of electrons.

Number of Electrons Removable from an Atom.—Although there may be a great number of electrons associated with an atom or molecule it is generally not possible to remove more than one; in a body which is positively charged most of the atoms are neutral, having their proper complement of electrons; others have had one electron removed. If but few of the atoms of a body have had an electron removed the body has a small charge; the more highly the body is charged the more deficient atoms there are on it.

From this viewpoint it seems that the amount of charge on a body should be counted; the charge consists of discrete things. Instead of saying that a body has a certain amount of negative electricity on it, we might more reasonably say that a certain number of electrons have been deposited on it.

Electric Fields.—If a light substance, such as a pith ball, is touched to a charged body, it becomes charged with electricity of the same polarity as that on the body itself; as like charges repel one another the pith ball will be repelled from the charged body. By experimenting it may be found that the repulsive force between the pith ball and the original charge exists even when there is considerable distance between the two. The space surrounding a charged body is evidently under some kind of strain which enables it to act upon a charged body with a force, attractive or repulsive, according to the relative polarities of the two charges. This space surrounding a charged body, in which another charged body is acted upon by a force tending to move it, constitutes an *electric field*, sometimes called an electrostatic field.

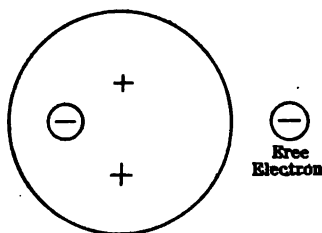

FIG. 2.—Conventional model of a simple atom charged positively, one of its electrons being free.

Such an electric field surrounds every charged body; it really extends to infinity in all directions from the charged body, but as the force becomes very small as the distance is increased it is generally considered that the electric field due to a charge extends but a short distance from the charge. For example, the field due to a piece of charged sealing wax is negligible at a point a few feet distant from the wax, so we say that the field of this charge extends but a few feet from the wax. On the other hand the electric field produced by a large, highly charged, wireless antenna may extend several thousand feet from the antenna.

Electric Fields Represented by Lines.—In diagrams the electric field surrounding a charge is most easily depicted by drawing lines from the charged body into the surrounding space. The direction of the lines, properly drawn, gives the direction of the electric force and the relative

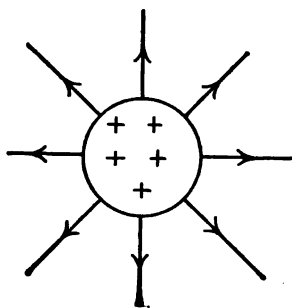

FIG. 3.—Electric field around a charged, isolated, sphere represented by radial lines.

closeness of the lines in various parts of the diagram shows the relative strengths of the field at these points, the closer the lines the more intense the field. A line of force originating on a positive charge is properly shown ending on an equal negative charge. In diagrams it is not always convenient to represent them; they may be shown as discontinuous. It must not be supposed, however, that the electric force itself is discontinuous; it always continues from a positive charge to a negative charge.

Fig. 3 shows how lines may be used to represent the electric field; it shows a positively charged metal ball supposedly far enough away from other bodies to be considered as by itself. The lines of force originate on the surface of the sphere and extend as radii in all directions. The arrow head on the lines indicates the direction in which a *positive charge* would be urged if placed in that part of the field.

The lines are closest together at the surface of the sphere, indicating that the force is greatest at this point, a fact easily proved experimentally. Although the lines are shown as discontinuous, ending in uncharged space, each line really extends in some direction until it encounters a negative charge. In the case of a metallic sphere, suspended in the air distant from other bodies, the lines should all be shown as ending on the earth's surface as suggested in Fig. 4. Fig. 5 represents the electric field between two parallel metallic plates, one of which has been charged positively and the other negatively. Moreover, as all the lines originating on the positive plate are shown as ending on the negative plate, it shows that the two plates have been given equal charges. The field is properly

shown as very intense between the two plates, weaker towards the edges, and very weak in the space not directly included between the two plates.

Closed and Open Electric Systems.—In Fig. 5 most of the electric field is shown directly between the plates on which the charges are situated;

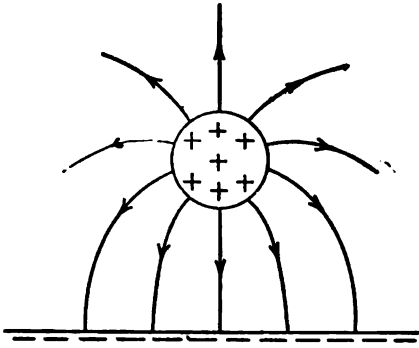

FIG. 4.

FIG. 4.—Charged body near the earth has its electric field radial near the body, all lines of force, however, bending over so that they end on the earth.

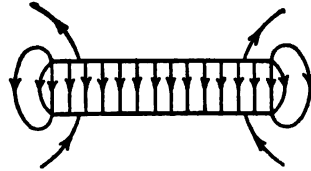

FIG. 5.

FIG. 5.—Two metallic plates, close to one another, one charged positively and the other negatively, have an intense electric field between the plates, and weak field elsewhere.

such distribution of lines indicates a nearly closed electric system. The field illustrated in Fig. 4 is a comparatively open one; the distinction between open and closed fields is not a very sharp one, but is nevertheless a very important one for the radio engineer.

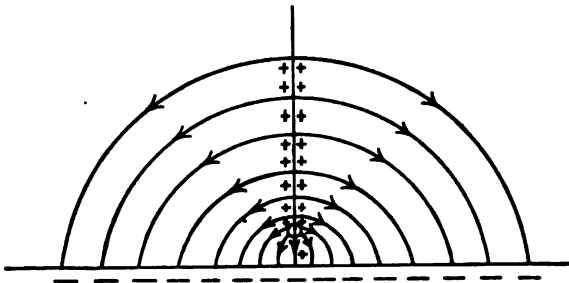

FIG. 6.—The electric field around a charged vertical wire.

Fig. 6 represents a vertical wire antenna, such as Marconi used in his early experiments; the electric field when the antenna is charged has the form shown. If the antenna is bent over in the form of an inverted L, the field has the form shown in Fig. 7. With the antenna in this form

most of the electric field is evidently included directly between the earth's surface and the antenna wire, so the field is a closed one as contrasted with that of Fig. 6, which is regarded as an open field. The operating characteristics of the two antenna shown are quite different, the difference being due to the different distribution of the field in the two cases.

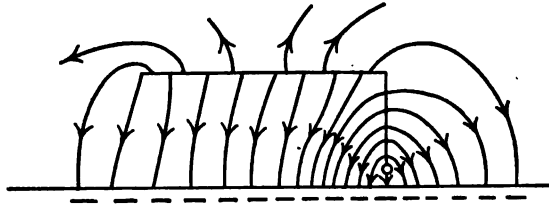

FIG. 7.—The electric field around an ordinary antenna.

Induced Charges.—Suppose a charged metal ball is brought close to another conducting body, as a metal rod, the rod being uncharged. Experiment shows that as the rod is brought into proximity of the brass ball the rod itself becomes charged in a peculiar way. If the ball is positively charged that end of the rod nearer to it becomes charged negatively and the farther end becomes positively charged as indicated in Fig. 8. As a whole the rod is not charged, there being as much negative charge as

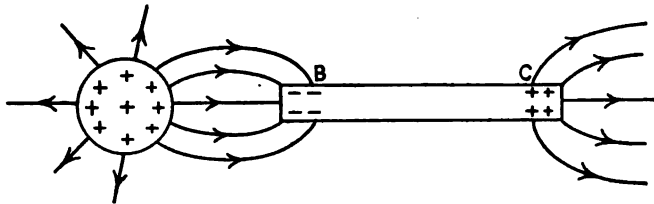

FIG. 8.—A charged body inducing charges on a metal rod.

there is positive charge. These charges which have been produced on the rod through the action of the charged ball are called *induced charges*.

Charges induced on a body are always double in kind; as much positive charge appears as does negative. However, if in Fig. 8 a wire having one end connected to the earth is touched to the end of the rod marked C, the positive charge which has been induced at this end of the rod will run off to the earth, and when the wire is removed there will be left of the rod only the negative charge.

Bound and Free Charges.—In the case considered above the positive charge runs off to the earth because there is no force tending to hold it on the rod, on the contrary it is being repelled by the positive charge on the ball. The negative charge at B is held from running off to earth

by the attractive force of the positive charge on the ball. The negative charge on the rod is called a *bound* charge and the positive charge which runs away if given the opportunity is called a *free* charge.

An illustration of the way in which this method of producing charges is useful in radio circuits is shown in Fig. 9. The charge on ball *A* is to produce a charge of the opposite kind on the conductor *F* through the two condensers *BC* and *DE*. When *A* comes in contact with *B*, this becomes positively charged.

A negative charge appears at *C* due to the inducing action of *B*. An equal positive charge must appear at *D* and this must induce a negative charge on *E*. But if a negative charge appears at *E* there must be an equal positive charge induced

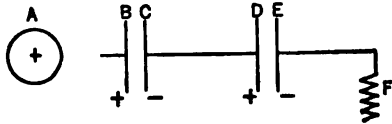

FIG. 9.—A charged body inducing charges on conductor *F*, acting through two condensers.

on *F*. If now the conductor *F* is connected to the ground this positive will run off to earth and there will be left on the conductor *EF* a negative charge. This charge will, however, be bound by the positive charge on *D*; if *B* is now grounded (connected to earth) its charge will run off and so the negative charge on *C* becomes free. This free charge on *C* will combine with the positive charge on *D* and neutralize it, thus leaving on the conductor *EF* a free negative charge.

Induced Charges from the Electron Viewpoint.—As will be explained later, the electrons in a metallic conductor are more or less free to pass from one atom of the substance to another; they are continually moving around the complex molecular structure of atoms comprising the metal. When the rod of Fig. 8 is brought into the neighborhood of the charged ball the electric field due to the charge on the ball acts on the free electrons of the rod, attracting them. Hence the free electrons of the rod tend to congregate at that end of the rod which is nearest to the ball; they constitute the negative charge at this end of the rod.

But if the rod was uncharged before coming into the influence of the charged ball there must be just enough electrons on it to neutralize the positive charges of the atoms. If more than a proper portion of the electrons gather at one end of the rod there must necessarily be a shortage of them at the other end. This shortage of electrons at the end *C* of the rod constitutes the positive charge at this end.

When the end *C* is grounded, the positive atoms of the rod cannot leave the rod and go into the earth, but electrons from the earth can run up into the rod and they do so, being attracted by the deficient atoms at *C*. These electrons from the earth appear in sufficient quantity to make the atoms at *C* neutral. When the wire connecting the rod to the earth is removed and the charged ball is also removed the rod has on it a free

negative charge, the quantity of charge being equal to the number of electrons which came from the earth into the rod.

An Essential Difference between Positive and Negative Charge.—As before stated, the electrons from all substances are the same; the electrons have none of these qualities by which we distinguish and classify matter. It is possible to have electrons in space entirely devoid of matter; a negative charge can exist in a perfect vacuum.

The question may be raised—How can it be a perfect vacuum if there are electrons present? By a vacuum we mean a space in which there is no material substance, solids which can be bodily removed, liquids which can be poured out, or gases which can be pumped out. A glass vessel which has been evacuated as perfectly as modern pumping methods can accomplish may nevertheless be filled with millions of electrons.

From our conception of the positive charge, however, it is evident that a positive charge must always be associated with matter, in fact the smallest positive charge is an atom of matter from which an electron has been removed. If in a glass bulb supposedly evacuated it can be shown that under some circumstances positive charges exist the vacuum is only partial; to the same extent that positive charges occur in the supposedly vacuous space, must matter of some kind (generally gas) be present.

The Electric Current.—The electric current is more familiar to everyone than the electric charge. The current manifests itself in various ways, by generating heat and light, by producing mechanical forces such as those required to ring a doorbell or pull a subway train, by producing chemical changes such as occur in the production of aluminum, or electroplating, by producing death if it flows through a living organism with sufficient intensity, etc.

Older conceptions of the electric current made it a peculiar fluid of some kind, others made it consist of two fluids with different properties. From the electron standpoint the conception of the electric current is easy to comprehend and enables one to give a fairly logical explanation of the various actions of the current.

Nature of the Electric Current. *An Electron in Motion Constitutes an Electric Current.*—The amount of electricity on one electron is so small that the current produced by one electron in motion would not be detectable by the finest current-measuring instrument, even the most sensitive. To produce currents of the magnitude occurring in every-day experience requires the motion of electrons measured in billions of billions per second.

An ordinary incandescent lamp requires a current of about one ampere; such a current requires that about 10^{19} electrons flow past any point in the circuit each second. This large number per second might be brought about by a comparatively few electrons moving rapidly or by a great

many moving more slowly. Contrary to what one would naturally think the progressive movement of the electrons is very slow. To produce a current of one ampere in a copper wire one millimeter in diameter requires that the average velocity of the electrons be only .01 cm. per second.

Although the progressive motion of the electrons is very slow, as indicated above, it must not be thought that the actual velocity of the electrons is small. If we assume the "equi-partition of energy" idea of thermo-dynamics and thus calculate the average velocity of the electrons in a copper wire, at ordinary temperature, we obtain a result of about 6×10^6 cm. per second. That is, even when no current is flowing in the wire the electrons have a haphazard motion, due to the thermal agitation of the atoms (or molecules), which give them, on the average, a velocity of about 35 miles per second.

Now when current flows the required progressive velocity of the electrons is only a fraction of a centimeter per second; with a current so large that the copper wire is heated to the melting-point the velocity of drift of the electrons is less than 1 cm. per second. Thus an accurate concept of the electric current in a conductor shows it to be an inappreciable "drift" of the electrons which have, due to temperature effects, heterogeneous velocities millions of times as great as the velocity of drift.

The reason for the slow progressive motion of the electrons is to be seen in the tremendous number of collisions they have with the molecules of the substance. A given electron, acted upon by the potential gradient in the wire carrying current, accelerates very rapidly and would acquire tremendous velocities if it did not continually collide with the more massive molecules; the mean free path of the free electrons in a copper wire is so small that, between successive collisions, the electron falls through a very small potential difference and hence gains a velocity (along the conductor) due to the current, which is extremely small.

Suppose that we wanted to measure the rate of flow of people past a given point in a large city; the unit of flow might be 100,000 persons per hour. At any time there will be people going in all directions, some uptown, some downtown, and some crosstown. In the morning a million people pass a certain point where the flow is to be ascertained. If 200,000 move in the uptown direction and 800,000 move downtown, the net flow is 600,000 people. If this number of people pass in one hour the flow is 6 units downtown. At noon time again a million people pass the same place let us suppose; 400,000 move uptown 400,000 move downtown and 150,000 move crosstown west and 50,000 move crosstown east. The net flow is now 100,000 people west and if this number pass in one hour the flow is one unit west. Some of the people would be moving rapidly and others going more slowly and some might, at times, be standing still.

The picture suggested by the above traffic analysis probably gives one a reasonable idea of the motion of electrons in a conductor carrying current; it is of course too simple, because of the immense number of electrons in a conductor and the tremendous number of collisions occurring between the electrons. When a conductor is carrying no current the motion of the electrons resembles that of the individuals in a stationary crowd; there is a deal of agitation among the electrons, but they, on the whole, show no progress along the conductor.

Electromotive Force.—Suppose a copper rod, having in itself the heterogeneously moving electrons suggested above, is connected at its two ends to a battery as shown in Fig. 10. The end *A* of the rod becomes positive with respect to end *B* and the electrons, instead of moving backwards and forwards to the same extent, progress slowly towards *A*. When they arrive at *A* they leave the copper rod, move down the connecting

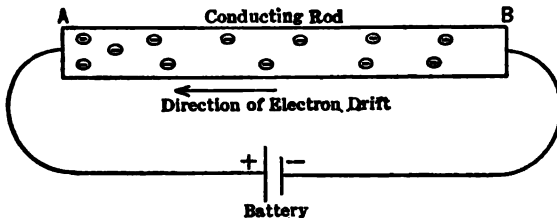

FIG. 10.—Electric current caused by flow of free electrons.

wire, through the battery, through the other connecting wire, and so back to the rod. As long as the circuit remains closed as shown the electrons will continue to move around the circuit, bounding backward, forward, and across the conductor, but on the whole progressing gradually around the circuit; this progression of the electrons constitutes the electric current. The cause of the flow is the battery; it holds one end of the rod positive with respect to the other and so maintains the flow of electrons. The maintenance of this difference of electric pressure (or difference of potential) across the rod is due to chemical changes going on inside the battery.

A piece of apparatus which has the ability to maintain one of its terminals at a higher potential than the other, even though current is allowed to flow through it, is said to develop an *electromotive force*. As sources of electromotive force for the production of currents on a commercial scale we have only the ordinary battery and the electric generator. The battery depends upon chemical action for maintaining its difference of potential and the generator depends upon the conductors of its armature being driven through the magnetic field produced by its field poles.

Electromotive Force and Difference of Potential.—It is well to distinguish between electromotive force and difference of potential. Thus two brass balls, one charged positively and the other negatively, have a difference of potential between them and they will, if connected by a wire, cause a momentary flow of current through the connecting wire; when sufficient electrons have passed from the negatively charged ball to neutralize the positive charge on the other the current will cease. There is no action taking place which tends to maintain the difference of potential between the two balls; such a combination does not generate an electromotive force (hereafter abbreviated e.m.f.).

In the case of the battery or generator, however, when the two terminals are connected by a wire a current flows and continues to flow until the battery is worn out or the generator is stopped; such devices develop or generate an e.m.f. These ideas are depicted in Fig. 11.

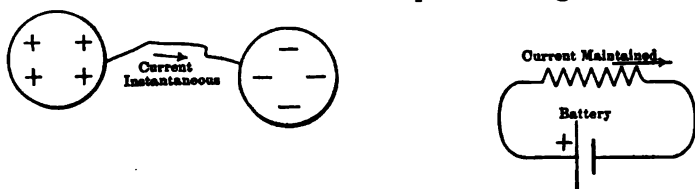

FIG. 11.—Illustrating difference between electromotive force and potential difference.

Direction of Flow of Current.—It has been accepted as convention that in a wire connecting the poles of a battery the current flow is from the positive pole of the battery to the negative. But by reference to Fig. 10 it is evident that in the connecting wire the electrons flow from the negative pole of the battery to the positive. Hence it must be remembered that although we shall talk of the current flowing from the positive terminal to the negative terminal of a battery or generator the electrons (which really are the current) are flowing in the opposite direction. In dealing with currents through vacua the motion of the electrons themselves is generally had in mind and we often say that the electron current flows from the negative to the positive terminal of the vacuum tube. Although this sounds anomalous it is a correct statement of the facts.

Conductors and Insulators.—Roughly speaking a conductor is a body which readily permits the passage of an electric current and an insulator is a body which offers a very high resistance to the passage of the current. There is no sharp distinction between conductors and insulators, however; a material which for some cases would be regarded as an insulator would, in other circumstances, be regarded as a conductor. Also a substance which is a good insulator at low temperatures may be a fair conductor at high temperatures.

Glass is the most striking illustration of this change of character with

change of temperature; at ordinary temperature it ranks high with the very best insulators, but if it is heated in some way to a red heat it becomes a fair conductor and will permit the passage of enough current to melt itself.

Difference between Conductors and Insulators from the Electron Viewpoint.—When a conductor is carrying an electric current the electrons throughout the substance of the conductor are moving gradually along through the substance of the conductor. Now in a solid body, such as a metallic conductor, the atoms or molecules comprising the substance are practically fixed in position. They are not actually stationary in space at ordinary temperature of course; as a matter of fact the atoms have an irregular to-and-fro motion similar to that of the electron. But *there cannot be a progressive motion of the atoms as there may be of the electrons*. The reason for this is more or less evident. Suppose a copper wire is fastened to the terminals of a battery and that current is flowing as indicated in Fig. 10. The electrons move all the way around the circuit through the wire, connections, solution in the battery, etc.

As the atoms of copper are charged positively after an electron has left them it might seem that as the electrons move from *B* to *A* through the wire the atoms would move from *A* to *B*, then into and through the battery and so back to the wire. But the atoms are the real substance of the wire, and hence if the atoms should progress one way or the other it would result in the copper itself being carried from one end of the wire to the other and then through the battery. This state of affairs is not possible in solid bodies like metals, it would result in the mixing of metals wherever a current left one metal and went into another.

In chemical solutions, e.g., copper sulphate in water, the salt molecule breaks up into two parts, one of which has one electron more than its proper number, the other part lacking one electron. The two parts of the molecule are called ions; the metallic ion (in above case, copper) lacks one electron and so is charged positively. If now a current is passed through such a solution the metallic ion does move through the solution and is carried from the solution to one of the wires by which the current is lead into the solution. Here the copper itself is transported by the current and we have the process of electro-plating.

From what has been said it follows that if the molecules of a body cling to the electrons so tightly that none of them are free to move away from the molecule there can be no current in such a substance. As long as the molecule keeps all its electrons it remains electrically neutral, and so has no tendency to move when in an electric field. This is the essential difference between insulators and conductors; in the one the electrons cannot move from the atom or molecule and in the other the electrons are perfectly free to leave the atom.

Disruptive Strength of an Insulator.—With the above idea in mind the possibility of break-down of an insulator, due to high voltage, becomes apparent. For low voltage the force tending to move the electron is not sufficient to break it loose from its atom. But it is reasonable to believe that, if the voltage gradient is made sufficiently high, any atom can be forced to let go of one electron, and such is the case. Such fine insulators as glass and mica break down and carry current when a great enough voltage is employed.

Effect of Temperature on the Disruptive Strength of an Insulator.—Imagine a good insulator heated by some outside source of power. The rise in temperature increases the to-and-fro motion of its molecules with the result that the collisions between the various molecules become more frequent and violent as the temperature is raised. As these collisions occur the resulting disturbances in the molecular structure tend to weaken the hold of the molecule on its electrons. Hence if an electric force is impressed and maintained as an insulator is heated the combination of electric force and weakening of the molecular holding power will result in some electrons leaving their molecules; the electric force then urges them along through the substance of the insulator with the result that a small current occurs. This would be interpreted by the man testing the insulator as a weakening of the insulating power of the substance.

Generally the partial breakdown of an insulator as described above is rapidly followed by the giving away of the insulator completely; as current, even though small, flows through the insulator it generates more heat thus still further decreasing the disruptive strength.

This effect of temperature upon the disruptive strength of an insulator is very important to the radio engineer. A glass or mica condenser, properly designed to operate in a radio circuit at 15,000 volts may, by improper use, be broken down when operating at only 5000 volts. Condensers heat up, when being used, due to various causes; in normal operation the condenser is excited only a small fraction of the time as the sending key is opened and closed. In the intervals when the key is open the cause of the heating is removed and the condenser has a chance to cool off; this alternate heating and cooling results in a certain mean temperature at which temperature the condenser has sufficient disruptive strength to withstand the voltage employed.

If now the normal operating voltage is put on the condenser and maintained continuously, the heating action is much greater than when the voltage is applied intermittently (normal operation) and in a short time the dielectric is likely to puncture. Condensers which are designed for operation at a certain voltage with spark telegraphy (intermittent excitation) will nearly always fail if operated at the same voltage for undamped wave signaling (continuous excitation).

Resistance.—In a conductor where the electrons are free to leave the atom their progressive motion is hindered by collisions with the atoms of the substance. *This hindrance to their free progress constitutes the electrical resistance of the conductor.* It differs, as might well be expected, in different metals, and it varies with the temperature. As the temperature of a metal increases the agitation of its atoms or molecules increases and this results in more hindrance to the progressive motion of the electrons because of the more frequent collisions between the electrons and the atoms.

The increase in number of collisions between the electrons and atoms with increase in the flow of electrons (more current) gives the atoms themselves an increased agitation, which really means a higher temperature; this accounts for the well-known fact that when a conductor carries current it always heats to some extent and heats more with large than with small currents.

Continuous Current and Alternating Current.—If the electrons in a conductor continually progress in the same direction the flow is called a *continuous current*, or *direct current*. Such is the current supplied by an ordinary battery.

If the battery is connected to the conductor first in one direction and then in the reversed direction, by some sort of a commutator, Fig. 12, the progressive motion of the electrons will reverse with every reversal of the battery connection. If this reversal of flow takes place at regular, short, periods of time the alternate ebb and flow of the electrons constitute an *alternating current*. In ordinary power circuits supplied with alternating current this reversal takes place about 60 times per second; the alternating

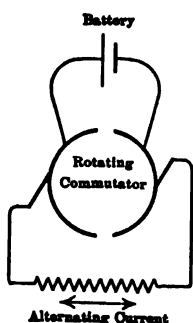

FIG. 12.—A battery in combination with a rotating commutator may produce an alternating current.

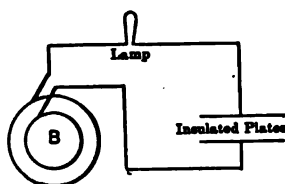

FIG. 13.—The lamp will burn even though there is a perfect insulator in series with the circuit.

currents used in radio circuits reverse much more rapidly, perhaps a million times per second.

Possibility of Alternating Current Flowing in a Circuit in Series with which there is a Perfect Insulator.—Suppose a circuit connected as indicated in Fig. 13; *B* is a source of alternating e.m.f. and *A* consists of two

metal plates separated by paraffined paper or mica. The disruptive strength of the insulator is such that for any voltage that *B* can give the insulation is perfect. A small incandescent lamp is inserted in the circuit to detect the current which may be flowing. The lamp will burn as soon as machine *B* is excited. Now if the lamp and *condenser* (the combination of two conducting plates and separating insulator) is connected to a battery which gives about the same voltage as machine *B* gives, the lamp will not burn, showing that there is no current in the circuit. Hence this circuit which is open for continuous current (i.e., it will not pass current) does permit the flow of alternating current.

The alternating current is possible because of the number of electrons required to *charge the condenser*. As the voltage of the alternator reverses in direction the condenser charges first in one direction and then in the other; this alternating charge and discharge requires the alternating flow of electrons throughout the whole circuit.

A simple analogy is shown in Fig. 14. Suppose a cylindrical chamber *A*, divided in the middle by a thin rubber diaphragm *B*, connected to a

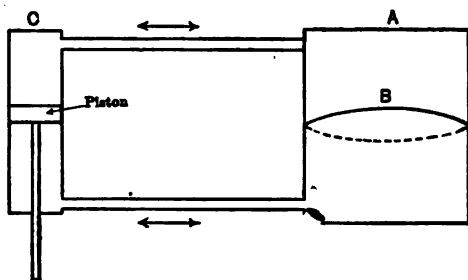

Fig. 14.—Hydraulic analogue of an alternating current circuit containing a condenser.

reciprocating action, valveless, pump *C*. As the pump works back and forth, water will circulate back and forth in the connecting pipes, constituting an alternating current flow of water. The diaphragm *B* will bend first in one direction and then in the other as the water reverses its flow.

Now suppose that a centrifugal action pump be substituted for the reciprocating pump (Fig. 15). This type of pump tends to force water always in the same direction. If the pump is so connected as to force water into the bottom of *A* and suck it out of the top of *A*, the flow of water will last long enough to stretch the diaphragm into some such position as *B'*, and then the flow will cease. At this position of the diaphragm the backward pressure of the stretched rubber will be just great enough to balance the pressure generated by the pump. In this water system the water would flow while the diaphragm was being displaced

from its normal central position to position B' , and then the flow would cease because the pump would not be able to further displace the diaphragm.

The water system corresponds very closely to the electrical circuit having a condenser in series with it and excited by a continuous e.m.f.; in such a circuit the current flows long enough to charge the condenser to such an extent that its back pressure (pressure tending to discharge the condenser) is just equal to the impressed e.m.f. and then the current ceases. It is to be remembered, however, that if the pressure is alternating there will be a flow in the system all the time, the current being an alternating one.

In electric circuits, therefore, it is possible to send an alternating current through a circuit in which continuous current cannot flow. Such

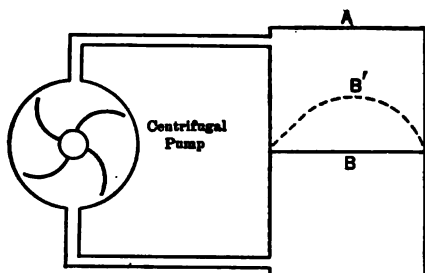

FIG. 15.—Hydraulic analogue of a direct current circuit containing a condenser.

use of a condenser occurs frequently in radio; the condenser so used is called a stopping or "blocking" condenser.

The Electric Generator.—Except for very small sets and emergency outfits the power for a radio set is obtained from a generator of either the continuous or alternating-current type. The continuous-current generator is equipped with a commutator and supplies a continuous e.m.f.; that is, the e.m.f. impressed on the connected circuit is always in the same direction and practically constant in value. There are slight pulsations in the value of the voltage, perhaps a fraction of 1 per cent, at the frequency of commutation; this frequency is in the neighborhood of 1000 cycles per second. Although these pulsations are so small, they have a deal of importance in certain radio sets using vacuum tubes for the generation of high-frequency currents.

The alternating-current generator (or simply *alternator*) has no commutator, but generally has slip rings on which its brushes make contact. The e.m.f. furnished by such a machine alternates in direction many times per second; for radio use the generators ordinarily employed give several hundred complete reversals of voltage per second.

The number of complete reversals per second is called the *frequency* of the generator; thus a 500-cycle generator is one giving 500 complete reversals of e.m.f. per second.

Wave Shape and Effective Values.—The form of voltage wave generated by a well-designed alternator is such that it can be closely represented by a sine curve as shown in Fig. 16. Expressed in the form of an equation,

$$e = E_m \sin \omega t \quad (1)$$

where

- e = the value of voltage at any instant of time;
- E_m = the maximum value of the voltage generated;
- $\omega = 2\pi f$, f being the frequency of the voltage.

The same units are used for measuring alternating voltage and current as are used for continuous voltage and current. But as the voltage

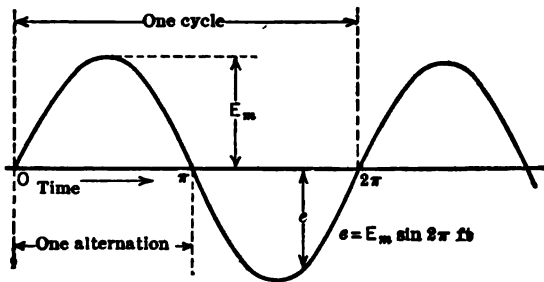

Form of alternating cmf.

FIG. 16.—Sine wave of e.m.f.

and current of an alternating current circuit are continually changing in value and reversing in direction, some value intermediate to the maximum and minimum value must be chosen as the unit. It is shown in all elementary texts on alternating currents that when the current flows according to the law of a sine curve *the alternating current will produce heat at the same rate as one ampere continuous current if the maximum value of the alternating current is 1.41 amperes.*

To get the value of that continuous current which will give the same heating effect as a certain alternating current, therefore, we take .707 of the maximum value of the alternating current. That value of continuous current which will produce the same heating effect as the alternating current in question is called the *effective* value of the alternating current. It is approximately .7 of the maximum value.

In the same way the effective value of an alternating e.m.f. (sine wave shape assumed) is .707 of its maximum value. Thus, if a sine wave

of voltage has a maximum value of 141 volts its effective value (or equivalent continuous voltage as far as producing heating is concerned) is 100 volts.

Magnetic Field.—The action of the magnet is familiar to everyone. If a piece of iron is placed in the vicinity of the magnet a force of attraction is set up between the two and the piece of iron will, if free to move, be drawn to the magnet.

All the region surrounding a magnet, in which the magnet is able to exert a force on pieces of magnetic material, is said to be filled with the field of the magnet. Thus the magnetic field is exactly analogous to the electric field surrounding an electrically charged body.

The magnetic field is represented by lines in just the same way as the electric field; the direction of the lines indicates the way in which the north pole of a compass would be urged if placed at that point of the field, and the proximity of the lines to each other serves to show the relative intensity of the magnetic force at various points of the field.

Magnetic Field Set Up by an Electric Current.—The field of the permanent steel magnet is interesting historically, but it plays very little part in the electrical engineering of to-day. When an electric current flows through a conductor a magnetic field is set up around that conductor; such a field is frequently called an *electro-magnetic field*. The magnetic fields used in modern apparatus are practically all of this type.

The strength of a magnetic field set up by an electric current depends upon the strength of the current, in general being directly proportional to the current strength. The direct proportionality holds good for magnetic fields without iron; use of iron in the magnetic circuit makes the relation between current and strength of field a complex one.

Ampere-Turns.—When the magnetic field is produced by a coil of several turns its intensity is much greater than if only one turn were used. The magnetizing effect of a current depends not only on the strength of current, but also on the number of turns through which the current flows. In fact the magnetizing effect of a coil is proportional to the product of the current strength and the number of turns in the coil; this product is called the *ampere-turns* of the coil. If a coil consists of one turn and is carrying a current of one ampere it has one ampere-turn; a coil of twenty turns carrying 2.7 amperes has fifty-four ampere-turns.

Direction of the Magnetic Field Produced by a Current.—The direction of magnetic field around a conductor carrying a current may be easily determined by the application of the following rule. Imagine the conductor grasped in the right hand, fingers around the conductor, with the extended thumb pointing along the conductor in the direction in which the current is flowing; the fingers then point in the direction of the magnetic field. This is illustrated in Fig. 17; it is to be remembered that

this rule assumes the commonly accepted direction of flow of current; in Fig. 17 the electrons are flowing in the opposite direction to that marked current.

As follows at once from the rule given above the direction of magnetic field reverses when the current reverses. If an alternating current is passed through a wire or coil the magnetic field produced will also be an alternating one, having the same frequency as the current, and *reversing simultaneously with the current.*¹

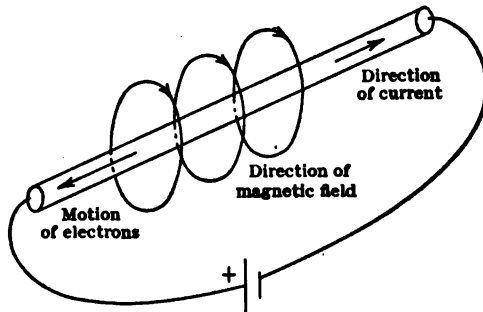

FIG. 17.—Direction of the magnetic field produced by a current.

Iron in the Magnetic Field.—In most electrical apparatus depending on the magnetic field for its operation the field is produced by currents flowing in coils. But the coils are usually fitted with iron cores so that the magnetic circuit consists partly of iron and partly of air. The reason for the use of iron in magnetic fields of electrical devices lies in its high permeability, i.e., the relatively high flux density produced by a given coil in iron compared to what it would produce if only air were used in the magnetic circuit.

The magnetic permeability of a substance is the ratio of the flux density produced in this substance by a certain magnetomotive force (magnetizing force) compared to the flux density the same magnetomotive force would produce in air.

For most substances the permeability has a value of unity; nickel, cobalt, and iron are the notable exceptions. Of these three iron is by all means the most important, not alone because of its comparative cheapness (and hence utility for electrical apparatus), but because of the high value of the permeability. For good magnetic iron it may be as high as several thousand; that is, if a given coil produces 500 lines of flux with a magnetic path of air it will produce perhaps a million lines of flux if iron is used for the whole magnetic circuit.

¹ This statement is strictly accurate only for the magnetic field in the immediate neighborhood of the conductor; for more distant points the magnetic field reverses somewhat later than the current. This idea is taken up more in detail on p. 700.

When the magnetic circuit of a device is made up partly of air and partly of iron, the flux produced by a given coil is intermediate to that which would be produced in a complete iron path, and that which would be produced in a complete air path. The shorter the part of the path through air compared to that through iron the higher will be the flux induced. The permeability of iron varies greatly with the treatment it received during manufacture; also for a given specimen it varies greatly with the magnetizing force used. This point will be taken up in more detail in the next chapter, under the head of *self induction* and its variations.

Units of Current, E.M.F., Resistance, etc.—The unit of current is the ampere; it is that flow of electrons which will deposit 1.118 milligrams of silver per second from a silver nitrate solution in a standard voltameter.

The unit of e.m.f. is the volt; it is generally defined in terms of the voltage of a standard Weston cell, which gives an e.m.f. of 1.0183 volts. The volt is therefore defined as 1.0000/1.0183 of the voltage generated by a standard Weston cell.

The unit of resistance is the ohm; it is really defined already¹ when the ampere and the volt have been defined because the three units are directly connected by Ohm's law. However, it is also defined as the resistance of a column of pure mercury weighing 14.4521 grams at 0° Centigrade and having a height of 106.3 cm., the cross-section being uniform.

The unit of quantity is the coulomb; it is the quantity of electricity transported by a current of one ampere flowing for one second. Another way of defining it is in terms of electrons; it is the amount of electricity contained on 6.38×10^{18} electrons.

The unit of work is the joule; it is the amount of energy required to transport one coulomb of electricity through an opposing potential difference of one volt. It is also the amount of work done in one second by a current of one ampere flowing against a pressure of one volt.

The unit of power is the watt; it is the rate at which work is done by a current of one ampere flowing against a pressure of one volt. It is therefore a rate of work equal to one joule per second.

Resistance of a Conductor.—The resistance of a circuit depends first of all on the kind of material used in making up the circuit; it depends upon the length of conductor used in making the circuit and upon the cross-sectional area of the conductor. This relation may be expressed by the equation,

$$R = \rho l / a, \quad \dots \dots \dots (2)$$

¹The ohm and the ampere are really the two fundamental units of the practical system. See American Handbook for Electrical Engineers, p. 1773.

where ρ = the specific resistance of the material used;

l = the length of the conductor;

a = the cross-sectional area of the conductor.

When the length of the conductor is one cm. and the area is one sq. cm. the value of R is the specific resistance per cm.³, and when the conductor has a length of one foot and an area of one circular mil the value of R is the specific resistance per mil-foot. In engineering the latter specification is more frequently used.

The specific resistance of some of the more common conductors is given in the accompanying table:

SPECIFIC RESISTANCE OF COMMON METALS, ALLOYS, AND SOLUTIONS

Substance.	Composition.	Microhms per Cm. ³ at 0° C.	Temperature Coefficient Referred to 0° C.
Advance	Copper-nickel	48.8	.000018
Aluminum	Pure	2.62	.00423
Brass	66 Cu + 34 Zn	6.29	.00158
Calido	Ni + Cr + Fe	100.	.00034
Carbon	Lamp filament	4000.	— .0003
Constantan	60Cu + 40Ni	49.	.00000
Copper	Standard	1.589	.00427
Copper	Electrolytic	1.56	.00428
German Silver	18Ni + Cu + Zn	33.1	.00031
La la soft	Cu + Ni	47.1	.00000
Iron	Pure	8.85	.00625
Iron	Hard steel	45.	.00161
Manganin	Cu + Mn + Ni	{ 40. 70.	{ .00001 .00004
Nickel	Electrolytic	6.93	.00618
Silver	Electrolytic	1.47	.00400
Tungsten	Hard	5.42	.0051
	Per Cent Solution.	Ohms per Cm. ³	
H ₂ SO ₄	5	4.80	— .012
	10	2.55	.013
	20	1.53	.014
	30	1.35	.016
	50	1.85	.019
	70	4.68	.026
KOH	20	2.01	— .020
HCl	20	1.31	— .015
HNO ₃	20	1.41	— .014
NaCl	2	37.	— .023
	5	14.9	.022
	10	8.2	.021
	20	5.1	.022

Practically all solutions have a minimum resistance with a density of solution between 20 and 30 per cent.

The resistance of a metal varies with the temperature, in general being directly proportional to the absolute temperature. This relation is approximately expressed for all *pure* metals by the equation,

$$R_t = R_0 (1 + at), \quad (3)$$

where

R_t = the resistance at t degrees Centigrade;

R_0 = the resistance at 0 degrees Centigrade;

t = the temperature at which the resistance is desired;

a = the temperature coefficient of resistance.

The value of a is very nearly .004 for all pure metals, for copper it has been decided to take a as .00427, at 0° C.

A statement which gives the above rule in words is as follows—the resistance of a pure metal increases approximately 1 per cent for each 2.5° rise in temperature above 0° C.

The resistance of a field coil of a generator which has a resistance of 25 ohms at ordinary temperature might have a resistance of 30 ohms after the machine had been operating a few hours; the rise would be due to the heating of the coil. A tungsten lamp has a resistance when hot about twelve times as much as the resistance it has at room temperature.

In certain materials the resistance may show considerable departure from the rule given above, thus in carbon an increase in temperature brings about a decrease in resistance. In a certain alloy of nickel and copper there is practically no change in resistance with ordinary temperature changes.

There are very strange resistance changes in certain substances, e.g., a large change in resistance takes place in selenium, according to the amount of illumination it receives; bismuth shows a large change in resistance, as it is introduced into a magnetic field and is sometimes used to measure the strength of magnetic field by the determination of its resistance.

The resistance of a salt or acid solution such as we have in primary or secondary batteries depends among other things upon the strength of the solution. This variation does not follow a simple law; there is a certain strength of solution which gives minimum resistance. For sulphuric acid solution such as is used in lead storage batteries the mixture which gives minimum resistance is made up with 30 per cent (by weight) acid.

The effect of temperature of the resistance of electrolytes is to give a decrease of resistance with an increase of temperature. The resistance decrease is about 2 per cent per degree Centigrade.

In case a circuit is carrying an alternating current the resistance may show all sorts of variations; it may be changed by bringing a piece of iron, or another circuit, into its magnetic field, by varying the frequency or

strength of current. These changes of resistance in so far as they have importance in radio work will be considered in the next chapter.

Induced Electromotive Force.—When current passes through a coil of wire it sets up a magnetic field in the coil and the strength of this field varies as the current varies. Now it is a fundamental law of the electric circuit that when the strength of magnetic field through a coil is varied an *e.m.f. is induced in the coil*; this law, which was discovered by Faraday, is called the law of induced e.m.f. The application of this law underlies the design and operation of nearly all electrical machinery and circuits.

Magnitude of Induced E.M.F.—The magnitude of the induced voltage depends upon the rapidity with which the magnetic field is changing and upon the number of turns in the coil, it being directly proportional to each of these factors. It is written

$$e = -N \times \frac{d\phi}{dt}, \dots \dots \dots (4)$$

in which

- e = the voltage induced at any instant of time;
- N = the number of turns in the coil;
- ϕ = the flux through the coil.

The minus sign is necessary because of the relation between the direction of the induced e.m.f. and the change in magnetic field, i.e., increase or decrease.

Direction of Induced E.M.F.—The change of flux is of course produced by a change of current; if the flux is decreasing it must be that the current in the coil is decreasing. *The direction of the induced e.m.f. is always such as to prevent the change of current which is producing the induced voltage.* Hence when the current (or flux) is decreasing, the direction of the induced e.m.f. is such as to prevent the decrease of current.

Suppose a circuit arranged as shown in Fig. 18; A is the battery, B is a coil, C is a switch, across which is connected a resistance D . With the switch closed current will flow in the direction of the arrow and will be fixed in magnitude by the voltage of the battery and the resistance of the coil. The resistance D will play no part in fixing the value of the current, because with the switch closed this resistance is cut out of the circuit, or short-circuited.

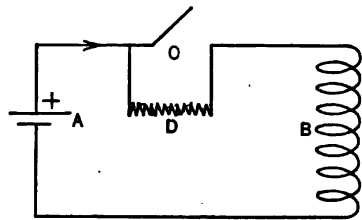

FIG. 18.—Opening the switch will reduce the current in the circuit.

A certain flux ϕ , will be set up in the coil, the value of this flux being fixed by the current. If now the switch is opened the current must change

to some lower value because of the added resistance D . This lower current will produce a lower flux ϕ_2 . While the flux is changing from ϕ_1 to ϕ_2 an e.m.f. will be set up in the coil B and the direction of the e.m.f. will be the same as the battery e.m.f., i.e., it will assist the battery e.m.f. in tending to maintain the current at its original value.

In Fig. 19 the switch is supposed to be closed until time A and here it is opened. The flux will decrease from the value AE to BF , the time taken for the change being that shown on the diagram between A and B . The decreasing flux generates a voltage in the coil shown by the curved line AIB , and this is in the same direction as the battery voltage, hence the total voltage acting in the circuit during the time $A-B$ is shown by the curved line GJH .

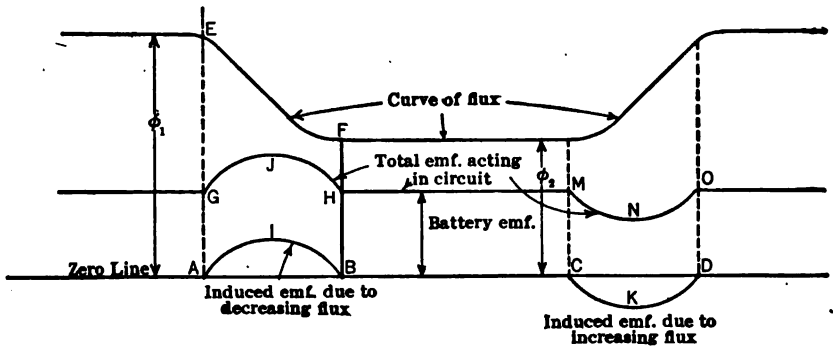

FIG. 19.—Curves showing direction of induced e.m.f.'s when current is increasing and when decreasing.

When the switch is closed again at time C the flux increases from ϕ_2 to ϕ_1 ; the induced voltage is now in the opposite direction and is shown by the curved line CKD ; it results in a total circuit voltage less than the battery voltage, as shown by the curved line MNO . (The shape of the induced voltage will not be exactly that shown by the lines of Fig. 19; these curves are only approximate indications of the actual form of the induced voltage. The exact form will depend upon the sparking taking place at the switch, etc.)

Summarizing the facts brought out by Fig. 19 and its explanation we have the proposition that when the current in an inductive circuit is decreasing the induced voltage acts to increase the total voltage of the circuit, when the current is increasing the induced voltage is in such a direction that the total voltage acting in the circuit is decreased.

Illustrating the above ideas there is a certain circuit used in radio in which a continuous voltage of 1200 volts is applied through a coil to the plate of a vacuum tube; as the current in this circuit pulsates, alternately increasing and decreasing from its normal value, the induced volt-

age in the coil has a maximum value of 1100 volts. When the current is increasing this induced voltage acts in the opposite direction to that of the generator furnishing the 1200 volts, so that the total voltage effective in maintaining current through the resistance of the circuit is only 100 volts. When the current is decreasing the induced voltage assists the generator voltage and the total effective voltage in the circuit is 2300 volts. The effect of induced voltage in this special circuit is to produce a pulsating voltage, between 100 volts and 2300 volts, although there is in the circuit a generator to supply the current which furnishes a continuous voltage of 1200 volts.

This voltage set up in a coil by the changing flux in the coil (the flux being caused by current in the coil itself) is called the *e.m.f. of self-induction*.

Coefficient of Self-induction.—Instead of expressing the magnitude of the induced voltage in a coil in the form given by Eq. (4) we may write

$$e = -L \frac{di}{dt}, \dots \dots \dots (5)$$

in which

- i* = the current in the coil;
- e* = the instantaneous value of the induced voltage, due to the changing current, *i*,
- L* = the coefficient of self-induction.

The coefficient of self-induction of a coil varies with the square¹ of the number of turns in the coil and inversely as the reluctance of its magnetic circuit.

If a given air core coil has an *L* of two units and the number of turns is doubled, the value of *L* is increased four times so it becomes eight units. If the magnetic circuit is changed from air to iron, the permeability of which is 1500, the *L* will be further increased 1500 times and so becomes 12,000 units. This increase is due to the iron decreasing the reluctance of the magnetic circuit 1500 times. If the iron core does not completely close the magnetic circuit, so that part of the magnetic path is still through air, the value of *L* is not increased to the extent stated above. For example, if the path through iron is 15 inches and the air part of the path is .01 inch long, then the value of *L* is increased 750 times, instead of 1500 times as stated.

The great increase in *L* produced by the use of iron for the magnetic circuit explains the almost universal use of iron cores (completely closed

¹This law holds good for any shape of coil if the magnetic circuit is a closed iron core, but for an air-core coil the law is approximate only; it is more nearly true as the turns of the coil are placed closer together.

when possible) in coils which perform their function owing to the value of their self-induction.

The unit of self-induction is defined by Eq. (5); if a rate of current change of one ampere per second gives an induced voltage of one volt, the coil has a self-induction of one unit. This unit is called the *henry*; the henry is, however, too large a unit for most of the coils used in radio work, so that subdivisions of the henry are used. The milli-henry is one thousandth of a henry and the micro-henry is the millionth part of a henry. Sometimes a still smaller unit is used, the centimeter, which is the billionth part of the henry. It may seem strange that the unit of length is also the unit of self-induction, but such is the fact; the derivation of the dimensions of the various units is outside the scope of this text. The coils used in "tuning" radio circuits vary from a few micro-henries to several millihenries, according to the frequency of the current being used.

Energy Stored in a Magnetic Field.—It requires work to set up a magnetic field just the same as it requires work to set into motion a heavy body. The greater the self-induction of a coil the greater is the work required to start current flowing in the coil; similarly the greater the mass of a body the greater is the work required to start it in motion.

The amount of work required to give a mass m , a velocity v , is measured by $\frac{1}{2}mv^2$, as shown in all texts on mechanics.

The amount of work required to set up, in a coil of self-induction L , the magnetic field caused by a current I is,

$$\text{Energy, or work} = \frac{1}{2}LI^2 \quad \dots \quad (6)$$

where L is measured in henries and I is measured in amperes and the energy is measured in joules.

The field coil of a large generator may have many joules of energy stored in its magnetic field; in radio circuits the amount of energy in the coils of a transmitting set is variable because the current is variable. The maximum value of the energy in the coils of the ordinary transmitter is about one joule per kilowatt capacity of the set.

Mutual Induction.—When the flux through a coil varies an e.m.f. is set up in it; if the flux is produced by current in the coil itself the e.m.f. is spoken of as the e.m.f. of self-induction, but if the flux is due to some other coil, in proximity to the one in which the voltage is being induced, the e.m.f. is spoken of as the *e.m.f. of mutual induction*. The voltage induced in the second coil is proportional to the rate of current change in the first coil (the one producing the flux) and the mutual induction of the two coils. The relation is expressed in the form of an equation

$$e_2 = -M \frac{di_1}{dt}, \quad \dots \quad (6)$$

where e_2 = voltage induced in the second coil;

i_1 = current in the first coil;

M = the coefficient of mutual induction of the two coils.

If e and i are measured in volts and amperes respectively, then M is measured in henries, the same unit as is used for L . For smaller values of M the same fractional parts of the henry are used as are used for L . M depends for its value upon the number of turns in each of the coils and upon their relative position; as the number of turns in either coil is decreased the value of M is correspondingly decreased and as the distance between the two coils is increased the value of M is again decreased. M may also be decreased by properly orienting the two coils with respect to one another. Imagine two cylindrical coils, shown in plan as rectangles in Fig. 20; M will have a relatively high value for the position

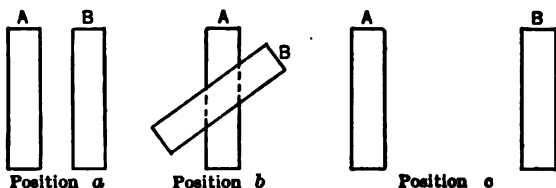

FIG. 20.—Variation of mutual inductance between two coils.

shown in *a* and will have a smaller value for either position *b* or position *c*. The scheme of rotating one of the two coils to diminish M has the advantage over the other method that it is compact and so permits the design of a set to be kept to smaller dimensions, a very important point if the sets are to be portable.

Coefficient of Coupling.—If all the flux produced by one coil threads with all the turns of the other, the coils are said to have 100 per cent coupling; if but a small fraction of the flux produced by the first coil threads the turns of the second, the coupling is weak. Also if all the flux of the first coil links with but a few turns of the second, the coupling is again weak.

The coefficient of coupling¹ between the two circuits is given by the relation

$$k = \frac{M}{\sqrt{L_1 L_2}}, \dots \dots \dots (7)$$

where k = coefficient of coupling, always less than unity;

M = mutual induction between the two circuits;

L_1 = the total self-induction of the first circuit;

L_2 = the total self-induction of the second circuit.

¹ A more detailed discussion of coefficient of coupling is given on p. 79.

M , L_1 , and L_2 must all be expressed in the same units.

As examples of the proper use of Eq. (7) in determining k , Fig. 21 is given; it is to be especially noted that if there are two or more coils in series and only one of them is used to couple the two circuits the total L of the circuit must be used and not the L only of that coil used for the coupling. Thus if two circuits are coupled to a certain extent by two coils in a certain position with respect to one another and another coil is added in series with one of these, *leaving the two original coils exactly as they were*, the coefficient of coupling of the two circuits has been lessened.

Practical Uses of Mutual Induction.—Whenever energy is to be transferred from one circuit to another, insulated from the first, the transfer must occur across a mutual electric or magnetic field, and generally this transfer utilizes a mutual magnetic field. That is, the energy flows from one circuit to the other because of the mutual induction of the two circuits. In a radio transmitting set mutual induction is used between the two coils

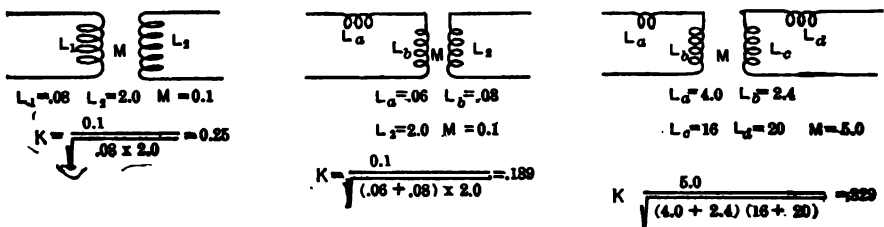

FIG. 21.—Examples of coefficient of coupling.

of the power transformer where the coupling is about 90 per cent; in the high-frequency oscillation transformer the coupling is about 20 per cent; in the coupler of the receiving set the antenna is coupled to the local tuned circuit with a coupling of perhaps 2 to 10 per cent.

Effect of a Short-circuited Coil on the Self-induction of a Neighboring Coil.—Suppose a coil A has a certain self-induction by itself; it will be found that if another coil B is brought close to A , and in such a position that M is not zero, the effective L of coil A is decreased, if the second coil is connected to form a closed circuit so that current can flow in it. The amount of decrease in L depends upon the coupling between the two coils, upon the frequency, and upon the resistance in the circuit of the second coil.

This effect is likely to occur in certain variable coils used in radio circuits; in the type of coil referred to the change in the self-induction of the coil is accomplished by using more or less turns of the coil by means of a sliding contact as indicated in Fig. 22. If the sliding contact B happens to make contact with two adjacent turns at once (quite a normal occurrence), there is one turn of the coil short-circuited, and this short-

circuited turn is quite closely coupled with that part of the coil which is being used. The effect of this turn is to decrease very much the effective self-induction of the part of the coil *A-B*, which is being used. Now as the slider is being adjusted it will, with very little movement, make contact with two turns or with only one turn; a signal may come in very strong at a certain setting of the slider and the slightest movement of the slider one way or the other will make the signal disappear. This is

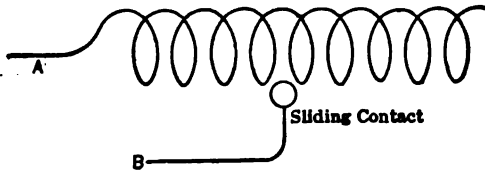

FIG. 22.—Variable Inductance with sliding contact.

due to the large change in the self-induction of the coil as the slider makes the short-circuited turn or does not make the double contact.

A short-circuited turn in a coil not only produces a decrease in the L of the coil, but it also increases very materially the resistance of the coil, and this is detrimental to the proper operation of the set; these two points will be taken up more in detail on pp. 85, et seq.

Capacity—Charging a Condenser.—Suppose a battery is connected through a switch to a condenser as indicated in Fig. 23. The condenser

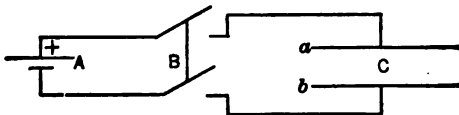

FIG. 23.—Charging a condenser.

C consists of two metal plates a and b , close together, but perfectly insulated from one another by the layer of air between them. When the switch B is closed the plate b is made negative with respect to a , by an amount equal to the e.m.f. of the cell, perhaps 1.5 volts; that this must be so follows from the fact that, when the switch is closed, b is connected to the negative end of the cell and a is connected to the positive end of the cell.

As the two plates a and b were at the same potential before the switch was closed, and after the switch is closed b is 1.5 volts lower in potential than a , the closing of the switch must have been followed by a flow of electrons in the direction from a to b . This redistribution of the electrons in the circuit, which serves to bring the condenser plates to the same difference of potential as are the terminals of the cell to which they are con-

nected, is called *charging the condenser*. A current flows during the short interval of time required for the redistribution of the electrons; this current is called the charging current of the condenser.

It is more or less evident that the condenser will take sufficient charge to bring its potential difference equal to that of the battery; as long as the condenser is at a lower potential difference than the terminals of the battery, the e.m.f. of the battery causes more electrons to flow; if, by any chance, so many electrons accumulate on the *b* plate of the condenser that potential difference of the condenser is greater than that of the battery, the excess of potential difference would so act as to make the condenser discharge itself until it was at the same potential difference as the terminals of the battery.

Capacity of a Condenser.—Suppose the amount of electron flow necessary to charge two different condensers to a certain potential difference is measured by a ballistic galvanometer or similar device. It will be found in general that the different condensers require a different amount of charge to bring them to the same difference of potential. For example, if two condensers are made of the same-sized metal plates, but in one the plates are only half as far apart as in the other, it will be found that the one with closer plates requires twice as much charge as the other; if two condensers have the same spacing for the plates, but one has larger plates than the other, again it will be found that one requires more charge than the other, in this case the one with the larger plates.

That characteristic of a condenser which determines how many electrons it takes to bring the condenser plates to a certain potential difference is called its *capacity*. A condenser which requires one coulomb of electricity to bring its plates to a potential difference of one volt, has a capacity of *one farad*. Such a condenser would require immense plates very close together; the unit is altogether too large to represent the capacity of ordinary condensers. In ordinary engineering practice, such as telephone circuits, the microfarad is used as the unit of capacity. A condenser of one microfarad requires a charge of one millionth of a coulomb to charge it to one volt. Stated in another way, a current of one ampere would have to flow only one millionth of a second to charge the condenser to one volt potential difference, or one microampere, flowing for one second would charge it to the same extent.

In radio circuits the microfarad is too large a unit to be conveniently used; a more suitable unit is the milli-microfarad, which is the thousandth part of a microfarad. Another unit is the micro-microfarad, which is one millionth of a microfarad. Still another unit is the centimeter; which is one nine hundred thousandth of a microfarad. The micro-microfarad and the centimeter are nearly the same-sized units, the centimeter being about 1.1 of a micro-microfarad.

The capacity of a standard Leyden jar used in radio sets is 2 milli-microfarads. The variable condensers used for tuning a receiving set have a maximum capacity of one milli-microfarad or less. Certain condensers used with vacuum-tube detectors have a capacity of 100 micro-microfarads. Antennæ, such as are used on small vessels, have a capacity of about 0.5 milli-microfarad, while large land stations designed for trans-oceanic communication may have antennæ of as much as 10 milli-microfarads capacity.

Specific Inductive Capacity.—Suppose a condenser made of two metal plates separated by $\frac{1}{8}$ -in. of air and let the quantity required to charge it to one volt be measured. Then let a $\frac{1}{8}$ -in. glass plate be slipped in between the two plates of the condenser and let the quantity be again measured; it will be found to be about six times as much as when air was used to separate the plates. If various other materials are used as dielectric it will be found that they all take more charge than the air condenser; in other words, when such insulators as glass, mica, rubber, etc., are used for the dielectric instead of air, the condenser has more capacity, its dimensions being the same in each case. The ratio of the capacity of a condenser in which some dielectric other than air is used, to that it would have if air were used, is called the *specific inductive capacity* of the dielectric. The values of this constant for some of the more common insulators are given in the table on page 167.

Energy Stored in a Charged Condenser.—It takes work, or energy, to charge a condenser; the amount of this work depends upon the capacity of the condenser and upon the voltage to which it is charged. The problem is analogous to the "pumping up" of a tire; the amount of work done in this case is evidently proportional to the size of the tire and depends in some way upon the pressure to which the tire is pumped. Actually the amount of work required increases with the square of the pressure to which it is pumped; pumping a given tire to 100 lbs. pressure requires four times as much work as is required to pump it to 50 lbs. pressure.

The energy used in charging a condenser, and stored in the electric field between the plates of the condenser, is

$$\text{Work} = \frac{1}{2}CE^2, \quad \dots \dots \dots (8)$$

where C = capacity of condenser in farads;

E = voltage to which condenser is charged, in volts, and the work is given in joules.

A condenser of .002 microfarad, charged to 15,000 volts difference of potential, has stored in its field .225 joule of energy. If the energy stored in this condenser is discharged to produce the oscillatory currents required in radio transmitter, it may be used to supply about 100 watts of power, with a suitable charge and discharge frequency.

This equation defines the expression "logarithmic rise of current." If a circuit has a very large value of inductance compared to its resistance, the rise of current may be so slow that it can actually be observed by means of an ammeter in the circuit. This is very easy to observe, for example, in the field circuit of a large generator, in which the current may take several seconds before it approximates its final value.

Time Constant of an Inductive Circuit.—When the time elapsed after the switch is closed is equal to the L/R of the circuit the current has risen to $(1 - 1/e)$ of its final value, or to about 63 per cent of its final value. The time taken for the current to reach this fraction of its final value is called the *time constant* of the circuit; in most inductive circuits it has a value only a small fraction of a second, but it may, in special cases, be several seconds.

The Oscillograph.—In investigating problems to-day the electrical engineer uses very extensively an instrument called the oscillograph. It receives its name from the fact that its essential part consists of a small mirror mounted on some fine wires, through which wires a current may be passed. The wires are mounted between the poles of a powerful magnet, and, due to the force acting between the magnetic field and the current in the wires, the mirror is caused to oscillate back and forth as the current in the wires changes its direction. This part of the instrument is really a small galvanometer so constructed that it can move very quickly a beam of light shining on the mirror and which, reflected therefrom, acts as a pointer to indicate the motion of the mirror. By suitable devices the motion of this beam of light may be either thrown on to a translucent screen and so serve for visual work, or it may be thrown to a rapidly rotating film and so give a permanent record of the excursions of the mirror. These films, showing how current varies with respect to time, are called *oscillograms*; such records will be frequently used in this text to illustrate phenomena being analyzed.

Such records are extremely valuable, as there are many rapid changes of current taking place in circuits which can be examined only in this fashion. Changes of current which are so rapid that they occupy only one-thousandth of a second are truthfully recorded by a properly used oscillograph; currents which alternate many hundred times a second are correctly shown by an oscillogram. Not only will the oscillogram show the number of times a second the current alternates, but it will also show how closely the current approaches a sine wave in form and similar effects.

In Fig. 24 is shown an oscillogram of the current rising in an inductive circuit; it will be seen that the current rises rapidly at first and gradually approaches its steady value. If the switch should be opened quickly in such an inductive circuit a large arc will form at the point of the switch where the circuit is opened. The energy stored in the magnetic field

has to disappear when the current dies to zero because there can be no magnetic field without current.¹ The greater the self-induction of the circuit the greater is the amount of energy (for a given current) and the larger will be the arc when opening the circuit. The decay of current in an inductive circuit cannot be well examined therefore by opening the circuit, but it can be shown by short-circuiting the coil in which the current is flowing. In such a case the current dies away on a logarithmic

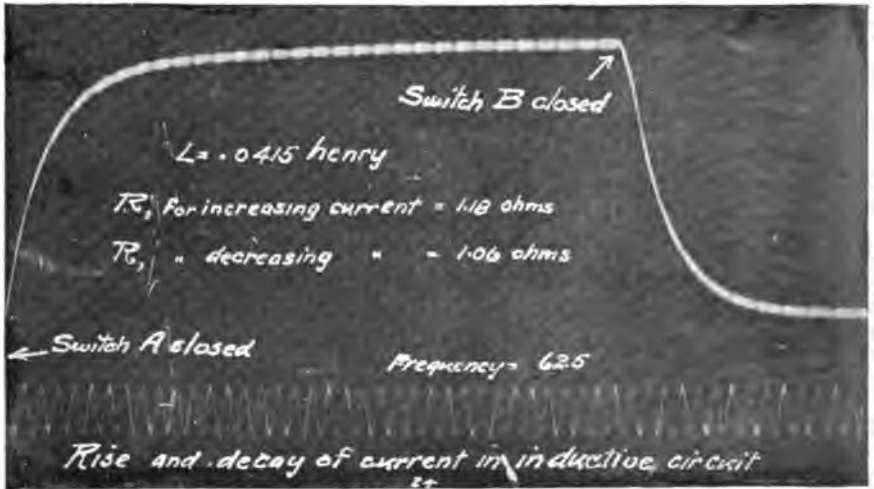

FIG. 24.—Oscillogram showing rise and fall of current in an inductive circuit.

curve quite similar to the curve of current rise. The equation of current decay is quite similar to that of the current rise and is

$$i = \frac{E}{R} \left(e^{-\frac{Rt}{L}} \right), \dots \dots \dots (11)$$

where the letters have the same meaning as in Eq. (10).

Fig. 24 serves also to show this effect, the circuit having been arranged as shown in Fig. 25. The battery *D* was connected to the inductance *C* through a low resistance *E* and switch *A*. The oscillograph was connected in the circuit at the point *O*. A second switch *B* served to short-circuit the coil so that the decay of current in it could be shown as well as the rise.

With *B* open, *A* was closed and so the oscillograph recorded the rise of current; when the current had reached its steady state switch *B* was closed, and the decay of current in the coil was recorded. The resistance

¹This statement of course neglects any residual field left in iron parts of the magnetic circuit when the current has fallen to zero.

E was used in the circuit to prevent the short-circuiting of the battery when *B* was closed.

The curves of rise and decay are just as is predicted by Eqs. (10) and (11); the two curves show a slight difference in the rate of change of current, but this is to be expected, because the resistance was somewhat greater for the rise of current than it was for the decay, while the inductance was the same for both. The time constant was greater for the decaying

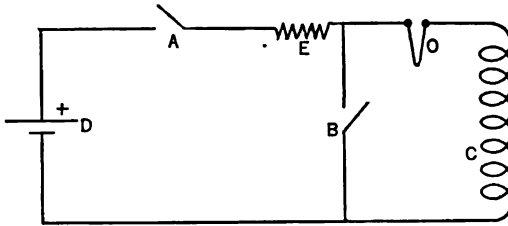

FIG. 25.—Circuit used to obtain oscillograms of growth and decay of current.

current than for the rising current; the rising current had for its resistance that of the coil, that of the battery, and that designated by *E*, while the decaying current took place through the resistance of the coil only.

Effect of Rising and Decaying Currents on Neighboring Circuits.—As the current in the coil increases and decreases it must induce electromotive forces in any neighboring circuits which are so placed that they link with its magnetic field. If the neighboring circuit is closed current will flow, in one direction when the current in the first circuit is rising and in the opposite direction when the current in the first circuit is falling. Hence when a circuit is closed and current starts to flow all neighboring

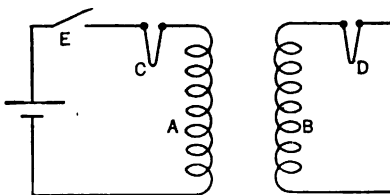

FIG. 26.—Circuit used to obtain oscillogram of currents in coupled circuits.

circuits, if closed, will have currents in one direction and in the opposite direction when the circuit is opened.

To bring out this fact a circuit was arranged as shown in Fig. 26; one oscillograph vibrator was introduced at *C* and the other at *D*. The currents which flowed in each circuit during the opening and closing of switch *E* is shown in the oscillogram given in Fig. 27. When the switch was closed current in coil *B* flowed in the opposite direction to that in coil *A*; when the switch was opened the current in *B* flowed in the reverse direc-

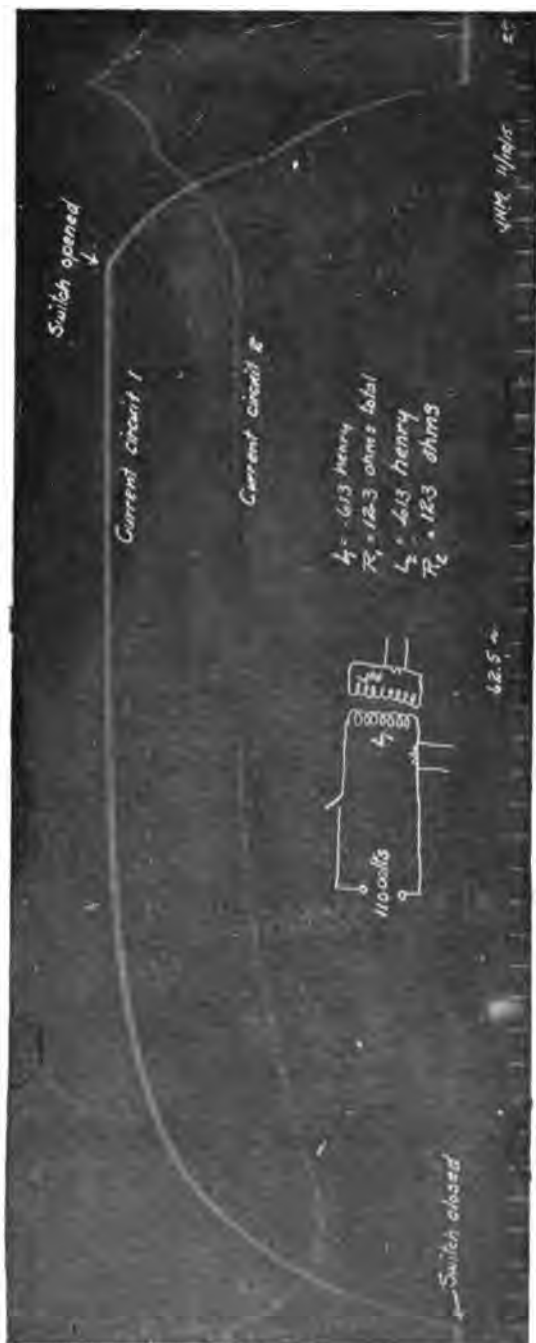

FIG. 27.—Oscillogram of currents in coupled circuits.

tion. The rather irregularly-shaped curve of current at the time of opening the switch was due to the fact that an arc formed at the point of opening the circuit so that although the switch was open the circuit was not open, the arc serving to keep the circuit closed. As the resistance of the arc was indefinite and variable the current naturally followed no regular curve.

Current Flow on Connecting a Condenser to a Source of Continuous E.M.F.—When a condenser is connected to a source of continuous e.m.f. the condenser takes sufficient charge to bring its plates to a difference of potential equal to the e.m.f. of the source to which it is connected. This charging would take place instantaneously if there were no resistance in the circuit. But the generator or battery to which the condenser is connected always has resistance and the condenser itself has a kind of resistance due to the losses occurring in its dielectric, all of these resistance factors act in such a way that the condenser takes an appreciable time to charge itself.

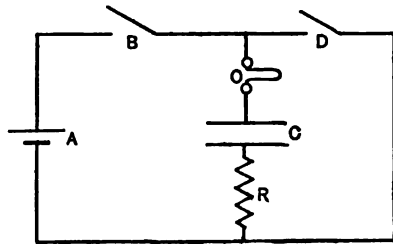

FIG. 28.—Circuit used to obtain oscillogram of charge and discharge of a condenser.

A circuit was arranged as shown in Fig. 28; *A* is a 100-volt battery, *B* and *D* are switches, *C* is the condenser to be charged or discharged, *O* is the oscillograph vibrator, and *R* is a resistance which represents the total resistance of the circuit, battery, connections, condenser, etc.

The equation which flows in such a circuit is given by

$$i = \frac{E}{R} (\epsilon^{-\frac{t}{RC}}), \dots \dots \dots (12)$$

- where *E* = the battery voltage in volts;
- R* = the total resistance of the circuit in ohms;
- C* = the capacity of the condenser in farads.

If now switch *B* is opened and switch *D* is closed the condenser will discharge and the current will be given by

$$i = -\frac{E}{R} (\epsilon^{-\frac{t}{RC}}), \dots \dots \dots (13)$$

where the letters have the same meaning as they have in Eq. (12). This current is evidently of the same shape as that taken by the charging operation with the exception that there is a minus sign before it; this

signifies that the discharge current is of the same form as the charging current, but it flows in the opposite direction.

Time Constant of a Condenser Circuit.—The quantity RC is called the time constant of the condenser circuit; it is evidently the time taken for the current to fall from its maximum value to 37 per cent of this value; another way of defining the time constant of a condenser circuit is in terms of the charge on the condenser; the time constant is the time required for the condenser to acquire 63 per cent of its final charge or, in the case of the discharging condenser, it is the time required for the condenser to lose 63 per cent of its charge.

Fig. 29 shows an oscillogram of charge and discharge which was taken from the circuit shown in Fig. 28. Some extra resistance must be necessarily added to the inherent resistance of the battery and condenser because the time constant of such a circuit is excessively small, too short for the oscillograph to function. Thus a one microfarad condenser in series with two ohms (a probable value for the battery) would have a time constant of .000 002 second, that is, the current would rise instantaneously upon closing the switch, to some value (depending upon the voltage used in charging) and in .000 002 second would have fallen to 37 per cent of this value, and in a correspondingly short time would have dropped to practically zero. Such an instantaneous occurrence is too rapid even for the oscillograph, hence to increase the time constant to a value suitable for the use of the oscillograph an extra resistance had to be introduced in the circuit.

The effect of adding resistance in series with a condenser to be charged is shown by the curves of Fig. 30; these were calculated from Eq. (12). They show that the initial current is cut down as the resistance is increased, in fact being equal to E/R , and that the duration of the current increases with the increase of resistance. The area between the X axis and any of the curves is the same; this area represents the quantity of electricity on the condenser and so must be the same for all conditions, because the quantity of electricity on the condenser after the charging process is complete is the same no matter what the resistance of the circuit may be.

Power Expended in a Continuous-current Circuit.—If a current of I amperes is caused to flow through a circuit by an e.m.f. of E volts the rate of doing work in the circuit is

$$\text{Watts} = EI, \quad \dots \dots \dots (14)$$

If the circuit has a resistance R we know that $E = IR$ and so

$$\text{Watts} = IR \times I = I^2 R \quad \dots \dots \dots (15)$$

from which we get

$$R = \frac{\text{Watts}}{I^2}, \quad \dots \dots \dots (16)$$



FIG. 29.—Oscillogram of charging and discharging current of a condenser.

Eq. (16) is important; it is the broadest possible definition for the resistance of a circuit. This formula gives the resistance for any kind of current flow, whether continuous, pulsating, or alternating. In words it is stated thus: *the effective resistance of a circuit is equal to the amount of power consumed by the circuit divided by the square of the current required to supply this power.*

In simple continuous current circuits Ohm's law is sufficient to obtain the resistance of the circuit, but there are many cases especially in alter-

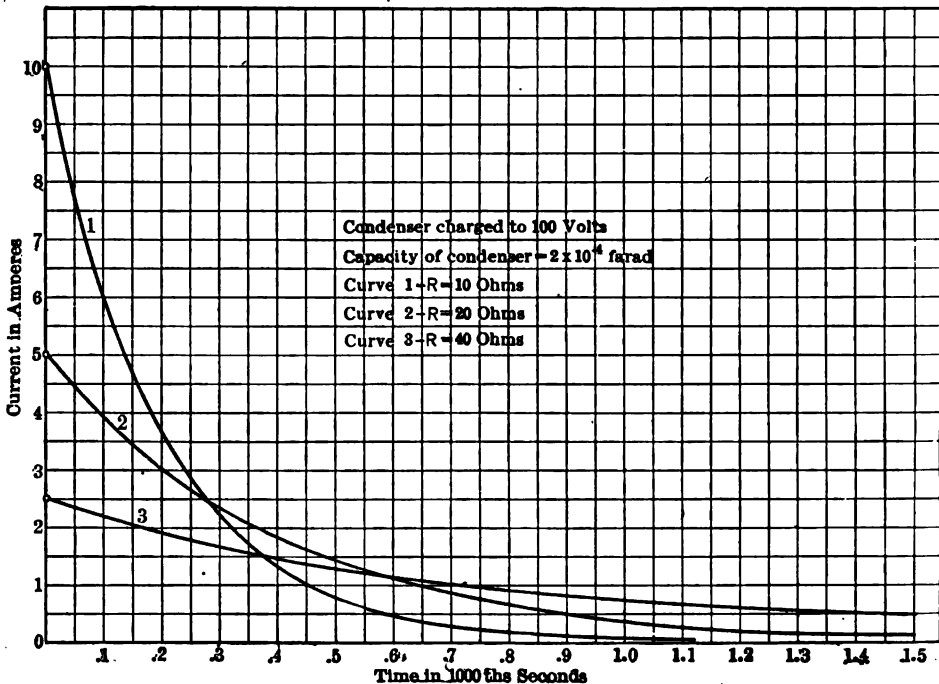

FIG. 30.—Condenser charging currents for different values of series resistance.

nating current work, where Eq. (16) affords the only feasible means of determining the resistance of the circuit.

Power Consumed in a Circuit Excited by Pulsating Current.—In case the voltage or current of a circuit, or both of them, are pulsating the power consumed in the circuit cannot be obtained by using the product of the average voltage by the average current, as might at first seem correct; an error would be introduced making the power consumed too low, the amount of this error depending upon the amount of fluctuation. The greater the amount of fluctuation or pulsation of the current or voltage, the greater is the error introduced.

The power is accurately obtained only by taking the product of the effective resistance of the circuit and the square of the effective value of the current. The derivation of the effective value of the current may be difficult; it can always be carried out graphically if the form of the pulsating current is accurately given, but is not easily calculated by ordinary arithmetic unless the form of the pulsation is very simple. Thus suppose that a pulsating current is simple enough to be represented by a continuous current, with a sine wave alternating current superimposed, as shown in Fig. 31. The actual pulsating current *A* is sufficiently well represented by the continuous current *B*, of amplitude I_1 , and a sine wave current *C*, of maximum value I_2 . The effective value of such a current is given by taking the square root of the sums of the squares of the effective values of the two components. The effective value of the continuous current is the same as its actual value, I_1 ; the effective value of the

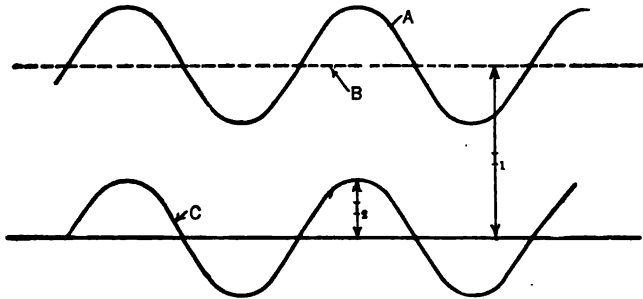

FIG. 31.—Pulsating current equivalent to a continuous current with alternating current superimposed.

sine wave of current is one-half the square root of its maximum value. Hence the effective value of the pulsating current is $\sqrt{I_1^2 + \frac{1}{2}I_2^2}$. The power used when such a current flows through a circuit of resistance R is

$$\text{Watts used} = I_1^2 R + \frac{1}{2} I_2^2 R$$

If the average value of the current were used in calculating the power used, the power represented by the second term would be completely neglected, and so an error would be incurred equal to $\frac{1}{2} I_2^2 R$. The amount of this error depends upon the amount of pulsation of the current. In such a circuit as the primary circuit of spark-coil transmitting set excited by storage battery the error would be very large, and the power used in the circuit cannot be obtained at all accurately without knowing the form of the current flowing in the primary winding of the coil.

The above statement is made with the idea in mind that in such a circuit as this, excited by storage battery, a direct-current ammeter would

be used in measuring the current. Now such an ammeter reads *average values* and so would read, when excited by such a current as sketched in Fig. 31, only the continuous-current component. Hence the error pointed out would occur. If, however, an alternating current ammeter were used for reading the current, the error would not occur, because such an ammeter reads *effective values*, and not average values. If the power used in a pulsating-current circuit is to be accurately determined, therefore, an alternating-current ammeter must be used to measure the current.

The above analysis of the power used in pulsating-current circuits holds good only when the resistance is constant throughout the cycle of current variation. In many circuits this is not so, the resistance being a function of the current and so changing as the current changes. The calculation of the power used in such a circuit is not easily measured by ammeters and voltmeters; either a *wattmeter* or the oscillograph must be used. The wattmeter is an instrument having two windings in the same case, one corresponding to an ammeter and the other to a voltmeter. An analysis of its action and the way in which it is used will be taken up in a subsequent paragraph dealing with the power used in an alternating-current circuit. The oscillograph, giving the form of voltage curve and current curve, makes it possible to calculate the power by graphical methods.

Current Flow in an Alternating-current Circuit Having Resistance only. Phase.—If an alternating-current generator is connected to a circuit having resistance only the relation between current, resistance, and voltage is given by Ohm's law. It is, of course, impossible to construct a circuit "with resistance only"; a circuit must have some inductance and capacity no matter how it is built, but if the amount of inductance and capacity are so small that their influence upon the current is negligible compared to the influence of the resistance, the circuit may be considered to have nothing but resistance opposing the flow of current. The filament of an incandescent lamp is such a circuit. A rheostat constructed of high-resistance wire may be considered to have no inductance when being used in ordinary alternating-current circuits, such as used for power and lighting, but such a rheostat would probably have such an amount of inductance that when used in a circuit of radio frequency it would be by no means negligible. It follows that a certain piece of apparatus might be considered free from inductance for some uses, but for other circuits the inductance might be of considerable importance.

In a circuit having resistance only the current and voltage have *the same phase* and are similar in form. A current and voltage are said to be *in phase* when they pass through their corresponding values simultaneously. The easiest point from which to judge the equality of phase is the zero value; if the two curves pass through their zero values at the

same instant they are in phase. In case the current passes through its zero value after the voltage has passed through its zero value it is said to be a *lagging current*; if it goes through the zero value before the voltage it is said to be a *leading current*.

In Fig. 32 are shown curves of current and voltage with (a) current and voltage in phase, (b) with current lagging behind the voltage by the angle ϕ , and (c) with the current leading the voltage by the angle ϕ .

The magnitude of the angle of lag or lead may be easily approximated when it is remembered that the time from one zero point to the next zero

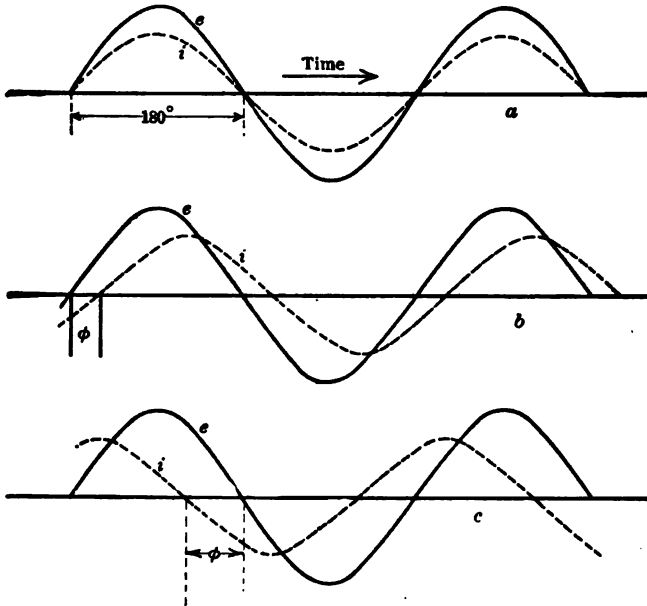

FIG. 32.—Phase difference of alternating current and voltage.

point of the same curve is 180° ; in curve *b* the current lags by about 30° and in curve *c* the angle of lead is about 70° .

In case the circuit has resistance only the relation between voltage and current is expressed by Ohm's law, whether instantaneous, maximum, or effective values are considered. Thus the equation for current flow in this circuit is

$$I = \frac{E}{R} \dots \dots \dots (17)$$

Power Used in a Resistance Circuit.—The rate at which electrical energy is changed into heat by a current *i* flowing through a resistance

R is i^2R , as has been shown for continuous-current circuits. Or, as we know that for the circuit $e=iR$ we have,

$$\text{Rate of heat development} = \text{power used} = e i$$

The power curve has the form shown in Fig. 33; it is at all times positive, because although both e and i go through negative values they both reverse at the same instant; the product, therefore, is constantly positive. The maximum value of this power curve occurs when both e and i pass through their maximum values and is therefore equal to $E_m I_m$.

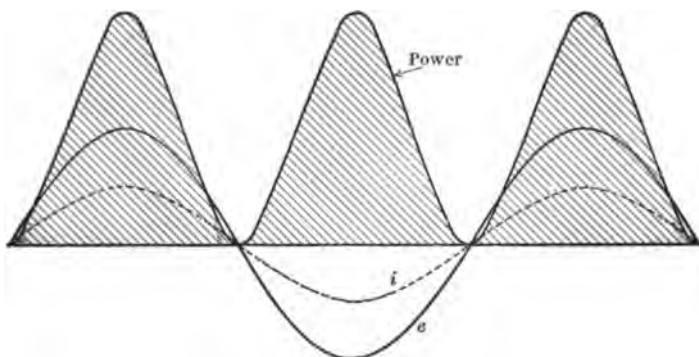

FIG. 33.—Power curve for an alternating current circuit containing resistance only.

If the equation of current is $i = I_m \sin \omega t$ and the equation of voltage is $e = E_m \sin \omega t$, the equation of the power curve must be

$$p = E_m I_m \sin^2 \omega t$$

$$= \frac{1}{2} E_m I_m (1 - \cos 2\omega t) \dots \dots \dots (18)$$

The average value of $\cos 2\omega t$ is zero, hence the average value of power

$$= P = \frac{1}{2} E_m I_m = EI \dots \dots \dots (19)$$

It is seen therefore that the power (in watts) used in an alternating-current circuit containing resistance only is the product of volts and amperes, as read by alternating current voltmeter and ammeter.

Meters Used in Alternating-Current Circuits.—It must be remembered that the ordinary continuous-current instrument, ammeter or voltmeter, will not read at all if used in an alternating-current circuit. Such instruments read the *average value* of voltage or current and, in an alternating-current circuit the average values are zero. To read correctly on an alternating-current circuit an instrument must give the same reading on a continuous-current circuit, no matter which way the continuous current is flowing through it; everyone familiar with the ordinary continuous-

current instrument knows that if the connection of the meter to the circuit is reversed the reading will reverse. Such an instrument, if actuated by an alternating current, would tend to oscillate between a certain direct reading and the equal reversed reading, but, as the alternating current reverses too rapidly for the needle of a meter to follow, it is evident that the meter would read zero no matter how much current was flowing through it.

Various types of meters are suitable for use on an alternating-current circuit, the dynamometer type, the soft-iron vane type, the induction type, the thermo-couple type and the hot wire type. The last two types named are used almost exclusively for making measurements in radio circuits, as it is practically impossible to make the other types function properly at the very high frequencies used in radio work.

Transient Current on Switching a Resistance Circuit to an A.C. Line.—If a resistance circuit is switched to an a.c. line the current rises instanta-

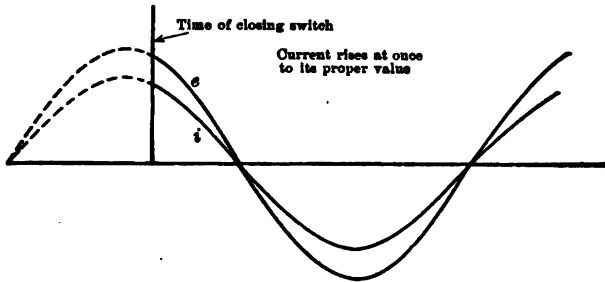

FIG. 34.—Current on switching a resistance circuit to an a.c. line.

neously to the value it should have, depending upon the value of the voltage at the instant the switch is closed, as shown in Fig. 34. This condition of affairs is expressed by stating that there is "no transient current" or no transient condition, after closing the switch; the current rises at once to the value it would have had (at the time of closing the switch) in case the switch had been closed at some previous time.

Current Flow in an A.C. Circuit Having Inductance and Resistance.—Suppose that an inductance (without resistance) and a resistance, connected in series, are connected to an a.c. line so that an alternating e.m.f. is impressed, as indicated in Fig. 35. Although the inductance must really have resistance, it is shown as resistanceless, all the resistance of the circuit being supposed concentrated in R . The current flowing in such a circuit depends upon four things, L , E , R , and the frequency of the impressed e.m.f. Provided that L and R are constant throughout the cycle (do not vary with the value of the current) it is a fundamental law of electrical circuits that the current will have the same form as the

impressed force. We may therefore assume that the current is a sine wave and then find its magnitude and phase.

The impressed voltage must be equal to the sum of the drops in potential across L and R .

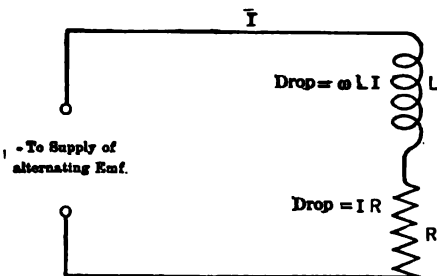

FIG. 35.—Resistance and inductance in series connected to an a.c. line.

Suppose the current to be $i = I_m \sin \omega t$.

The drop across the resistance = $iR = I_m \sin \omega t$.

The drop across the inductance = $L di/dt = \omega L I_m \cos \omega t$.

The impressed voltage must be

$$= I_m(R \sin \omega t + \omega L \cos \omega t) \dots \dots \dots (20)$$

In Fig. 36 these two component voltages are shown as curves; the impressed voltage e must be equal at all times to the sum of the resistance

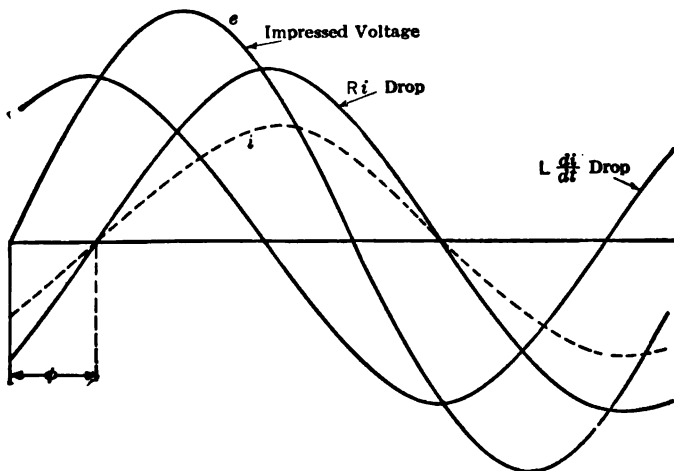

FIG. 36.—Voltage components in an a.c. circuit containing inductance and resistance.

drop and the inductance drop, and is so shown by the curve marked e in Fig. 36.

A vector diagram representing the curves of Fig. 36 is given in Fig. 37; effective values, instead of maximum values, are shown. From this diagram we have

$$E^2 = I^2(R^2 + (\omega L)^2)$$

or

$$I = \frac{E}{\sqrt{R^2 + (\omega L)^2}} = \frac{E}{Z} \dots \dots \dots (21)$$

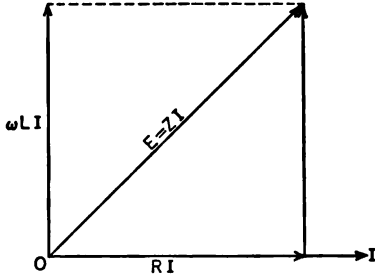

FIG. 37.—Vector diagram for an a.c. circuit containing inductance and resistance.

The quantity ωL is called the *reactance* of the circuit and the quantity Z is called the *impedance* of the circuit. The current lags behind the voltage by the angle ϕ , which is determined by the relation

$$\cos \phi = \frac{R}{Z} \text{ or } \tan \phi = \frac{\omega L}{R}.$$

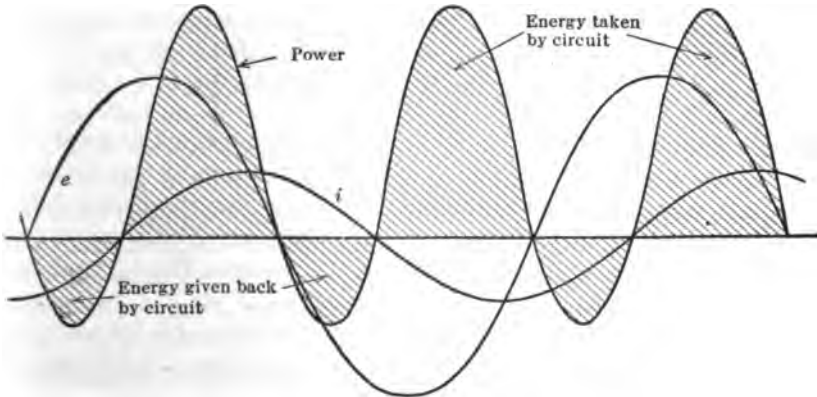

FIG. 38.—Power curve for an a.c. circuit containing inductance and resistance.

Power Used in an Inductive Circuit.—The power used, at any instant, in the circuit of Fig. 35 is obtained by multiplying the instantaneous value of e by that of i ; it is shown by the power curve in Fig. 38. For this circuit it is evident that the power is sometimes negative, i.e., the circuit,

instead of drawing power from the line, is actually furnishing power to the line. Energy which has been stored in the magnetic field of the inductance, is flowing back into the source of power supply.

The expression for the power is,

$$\begin{aligned} p &= E_m \sin \omega t \times I_m \sin (\omega t - \phi) \\ &= E_m I_m \sin \omega t \times \sin (\omega t - \phi) \end{aligned}$$

The average value of this expression is given by average value of the expression

$$p = \frac{E_m I_m}{2} \cos \phi (1 + \sin 2 \omega t) \quad \dots \quad (22)$$

So average power

$$P = EI \cos \phi \quad \dots \quad (23)$$

The power in the circuit is equal to the product of the volts and amperes in the circuit and the quantity $\cos \phi$. For this reason $\cos \phi$ is called the *power factor* of the circuit; it may have any value between unity and zero. In ordinary power circuits it has a value between about 0.7 and 0.95, very seldom being unity. In some parts of efficient radio circuits the power factor may be as small as .005.

The power may be expressed in terms of current and resistance by changing the form of Eq. (23).

$$\begin{aligned} P &= EI \cos \phi = EI \frac{R}{\sqrt{R^2 + (\omega L)^2}} \\ &= I \times I \sqrt{R^2 + (\omega L)^2} \frac{R}{\sqrt{R^2 + (\omega L)^2}} = I^2 R. \quad \dots \quad (24) \end{aligned}$$

This equation for the power used in an a.c. circuit is really a definition of the effective resistance of the circuit; the resistance of the circuit, for alternating current, may be entirely different from the continuous-current resistance of the circuit. There are many effects which combine to make the a.c. resistance sometimes several times as great as the c.c. resistance (or the a.c. resistance may be negative even, while the c.c. resistance is positive) and the only way¹ of measuring this resistance is by use of Eq. (24). The power used in the circuit is measured by a wattmeter, the current by an ammeter, and the resistance found by the relation

$$\text{Effective resistance} = \frac{\text{watts}}{I^2}. \quad \dots \quad (25)$$

¹ If the circuit is such that a measurement in an alternating current Wheatstone bridge is feasible, of course such method also is available. Even in the bridge determination the idea expressed in Eq. (24) is, however, involved.

Wattmeter.—It is generally not possible to measure the power used in an a.c. circuit by use of Eq. (23) because the phase difference of the voltage and current is not known and there is no easy method of measuring it directly. To get the power used in an a.c. circuit it is nearly always necessary to use a *wattmeter*. This is an indicating instrument, resembling an ammeter or voltmeter externally, but differing from these instruments in that it has two independent electrical circuits. Two coils inside the instrument, one in shunt with the circuit, and one in series with it, react on one another to produce the force which moves the indicating pointer. The theory involved in its operation is explained in practically any text on alternating-current measurements and will not be given here. The scale of the meter is calibrated directly in watts and, with a properly calibrated instrument, the reading of power is accurate no matter what the power factor may be; for very small power factors, and for circuits of frequency much higher than that for which the meter is intended, a correction may be necessary.¹

The power factor of an a.c. circuit is then determined from the readings of three instruments, ammeter, voltmeter, and wattmeter. The power factor, $\cos \phi$, is the quotient of the wattmeter reading by the product of the readings of the other two instruments. If it is desired to know the angle ϕ itself, it is only necessary to consult a table of natural cosines.

The effective resistance of the circuit is obtained by finding the quotient of the wattmeter reading and the square of the ammeter reading. As stated before, this resistance will generally be very different from the resistance measured by a continuous-current test.

Variation of Current with Frequency in an Inductive Circuit.—The magnitude of the current flowing in a circuit consisting of a resistance and inductance in series evidently depends upon the frequency (see Eq. 21).

At zero frequency (continuous current) this equation reduces to $I = E/R$. This relation holds good only after the switch has been closed long enough for the transient condition to disappear (see Fig. 24).

At very high frequencies the resistance becomes negligible compared to the reactance, and so the value of the current is given, very nearly, by the equation $I = E/\omega L$. As the frequency varies between high and low values, voltage being held constant, the current varies as shown in Fig. 39; for frequencies sufficiently high that R is small compared to ωL , the curve approximates a hyperbola,

$$I \times f = \frac{E}{2\pi L} \quad \dots \dots \dots (26)$$

Transient Current in a Circuit Having Inductance and Resistance.—After the switch has been closed for some time there is always a definite

¹ See Morecroft's Laboratory Manual of Alternating Currents, p. 11.

relation between the instantaneous values of the current and voltage; for every cycle the two go through exactly corresponding values. Thus

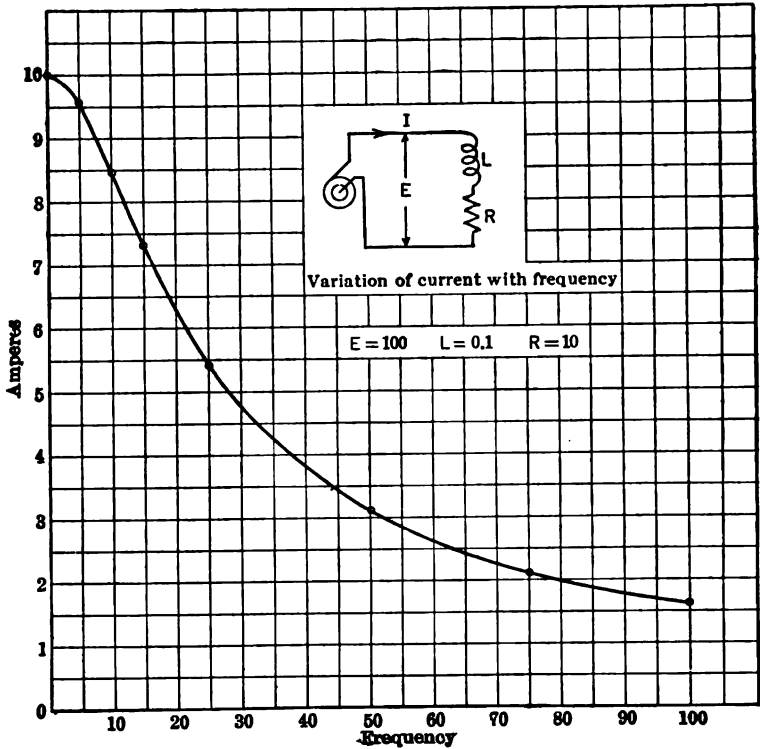

FIG. 39.—Current variation with frequency in an a.c. circuit containing inductance and resistance in series.

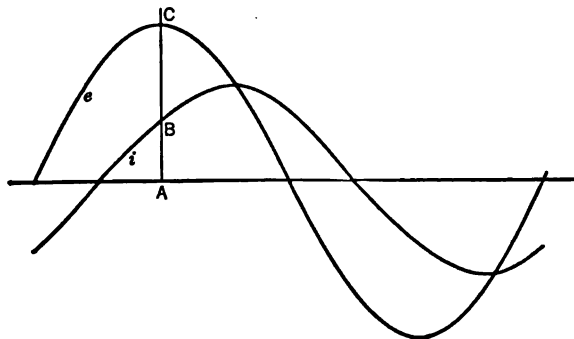

FIG. 40.—Curves of e and i in a circuit containing inductance and resistance, for steady state.

in Fig. 40, when e has a maximum value AC , the current has the value AB , and whenever the voltage has the value AC the current will have

the value AB . Now suppose the switch to be closed when the voltage has the value AC ; the current should have the value AB , but in an inductive circuit the current cannot rise instantaneously; this was shown by the oscillograms in Figs. 24 and 25. The complete equation for the current in an inductive circuit must therefore include a transient term as well as the term for the steady state; it is properly written

$$i = \frac{E}{\sqrt{R^2 + (\omega L)^2}} \sin(\omega t - \phi) + K\epsilon^{-\frac{Rt}{L}} \dots (27)$$

The second part of the current, $K\epsilon^{-\frac{Rt}{L}}$, is determined in magnitude by the value of the current, in the steady state, at the time in the cycle

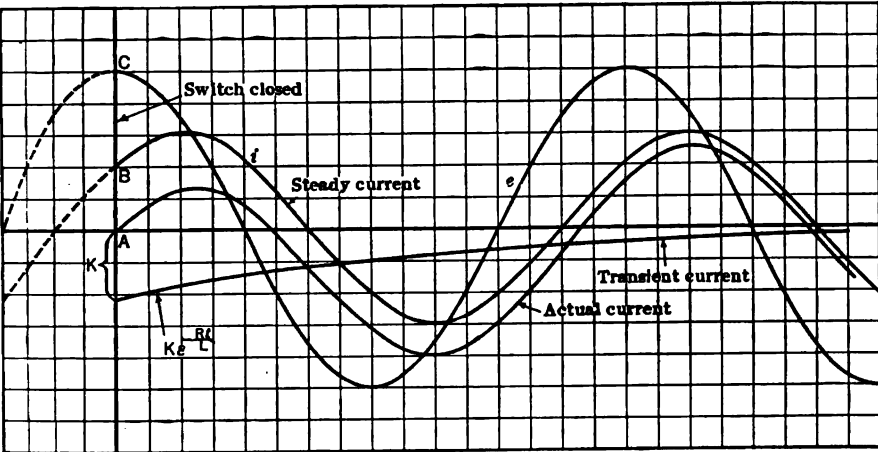

FIG. 41.—Curves of e and i in a circuit containing inductance and resistance for transient state.

corresponding to the time in the cycle that the switch is closed. Thus in Fig. 41, at the time of closing the switch the current should have the value AB ; this fixes the value of K in Eq. 27. In Fig. 41 is plotted the steady value of the current i , the transient current $K\epsilon^{-\frac{Rt}{L}}$, and the actual current for the first cycle after closing the switch; this actual current is the sum of the other two.

In Figs. 42 and 43 are shown oscillograms of the current flowing in an inductive circuit for the first few cycles after the switch had been closed; in one the switch was closed at the peak of the voltage and in the other it was closed when the voltage was very nearly zero. In Fig. 42 the effect of the transient term is plain; the current (steady value) has been plotted in dotted lines, as has also the transient term, the latter having been



FIG. 42.—The ordinary form of current occurring when switching an inductive circuit to an a.c. supply line; analysis of the actual current is shown by the dotted curves.

calculated from the value of the steady current at the time the switch was closed and the L and R of the circuit. It may be seen that the actual current is correctly given by Eq. (27). In Fig. 43 the switch was closed at that part of the e.m.f. cycle which, in the steady state, is the proper time for the current to be zero; it is seen that for this case the transient term reduces to zero, and the actual current is represented completely by only the first term of Eq. (27).

Circuits Having Resistance and Iron-core Inductance.—In case the L of the circuit, Fig. 35, consists of an inductance having a closed iron path for its magnetic circuit, the conclusions deduced will not be correct. The value of L in this case is not constant, but varies throughout the

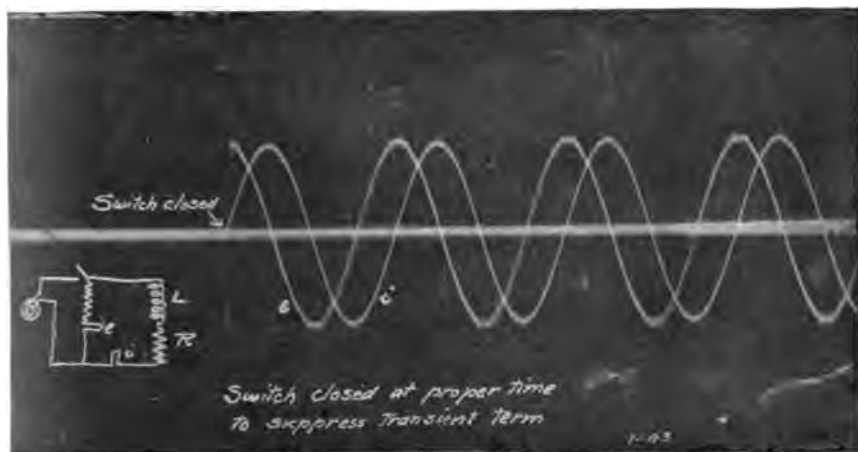

FIG. 43.—Oscillogram illustrating absence of transient current in an inductive circuit.

cycle, and for this reason the relation between the current and voltage is a complex one; the current in this case requires an equation with an infinite number of terms to express it accurately. The current, instead of being sinusoidal, has a decided hump, as shown by Fig. 44, which shows the magnetizing current of a closed-core transformer.

Not only is the steady value of current in such a circuit irregular, but the transient current may show even greater irregularities. This irregularity may last for many cycles, depending upon the kind of iron used in the core and upon its condition of magnetization at the time the switch is closed, as well as upon the part of the cycle selected for the closing of the switch. Thus in Fig. 45 is shown the current in the primary circuit of a transformer for a few cycles after closing the switch; the transient current may be so large in this case that during the first cycle the current never reverses its direction.



Fig. 44.—Curve of e.m.f. wave (with “ripples”) and the current it produces in an iron core inductance.

The rise of current in such an inductive circuit as this is not as simple as that illustrated in Fig. 24; the analysis given in explaining this figure assumed constant L so will not hold good if L varies during the rise of

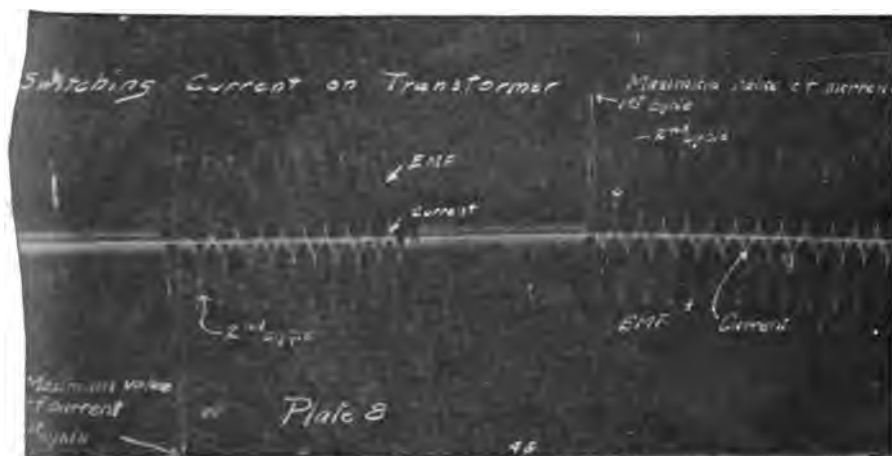

FIG. 45.—Oscillogram showing the transient current when switching an iron core inductance to an a.c. line.

current. The actual form of rising current in such a circuit, when connected to a c.c. line, is shown in Fig. 46; it is quite evidently different from that shown in Fig. 24, which was for an air-core inductance.

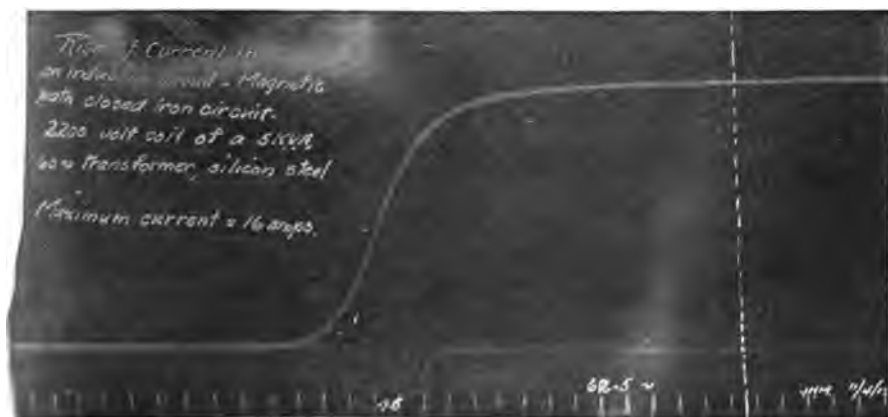

FIG. 46.—Peculiar growth of current when an iron core inductance is switched to a source of continuous e.m.f.

Current Flow in a Condenser.—By the definition of a condenser no electrons can actually pass from one plate to the other; they are insulated from one another. If, however, a condenser is connected to a source of

alternating e.m.f., current will flow in this circuit, as may be seen by the reading of an a.c. ammeter placed in series with the condenser.

Suppose a condenser of capacity C farads is connected to a line the e.m.f. of which is given by the equation $e = E \sin \omega t$. The condenser will, of course, take enough charge to bring the potential difference of its plates continually equal to that of the line to which it is connected. As this impressed e.m.f. continually varies in magnitude and direction, electrons must be continually running in and out of the condenser to maintain its plates at the proper potential difference. This continual charging and discharging of the condenser constitutes the current read by the ammeter. The electrons, the motion of which constitutes the current, do not actually pass from one plate of the condenser to the other through the dielectric;

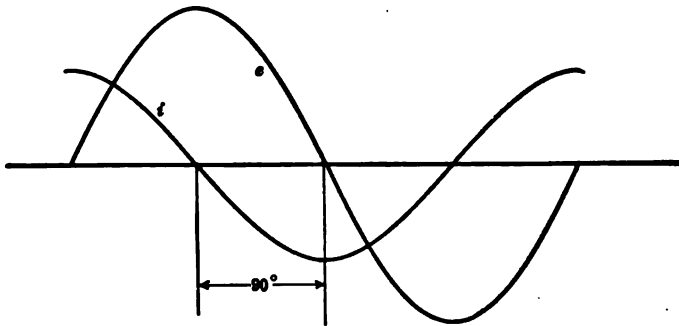

FIG. 47.—Current and voltage for a perfect condenser connected to an a.c. line.

they merely flow in and out of the condenser. With this idea in mind it is easy to see why the changing current of a condenser increases with the capacity of the condenser, also with the frequency of the impressed e.m.f.

The magnitude of the charging current is obtained as follows:

The charge $q = Ce$ and the current $i = dq/dt$.

Now $q = CE_m \sin \omega t$,

so

$$i = \omega CE_m \cos \omega t. \dots \dots \dots (28)$$

This current is then of the same form as the impressed e.m.f. (a cosine curve is similar to a sine curve in form) but leads it by 90° as shown in Fig. 47; its maximum value, in amperes, is equal to ωCE_m .

In effective values the relation between the impressed voltage and the charging current is,

$$I = \omega CE = 2\pi fCE \dots \dots \dots (29)$$

It is evident that, other things being equal, the charging current of a condenser is directly proportional to the frequency of the impressed e.m.f. This should be contrasted to the inductive circuit in which the current varies inversely as the frequency, if the resistance is small compared to the reactance.

The relation between the current and voltage may be written

$$I = E + \frac{1}{2\pi fC} \dots \dots \dots (30)$$

The quantity $\frac{1}{2\pi fC}$ is called *the reactance of the condenser*, generally specified as capacity reactance to distinguish it from inductance reactance $2\pi fL$.

Condenser and Resistance in Series.—If a condenser and resistance are connected in series and a sine wave of voltage is impressed, a sinusoidal current will flow; its magnitude and phase depend upon the R , C , E , and f of the circuit. Suppose this current to be given by $i = I_m \sin \omega t$.

The resistance drop = $I_m R \sin \omega t$.

The capacity reactance drop, in magnitude, is $\frac{I_m}{\omega C} \cos \omega t$. But as shown before, the current leads the voltage impressed on a condenser; the capacity drop is therefore properly written,

$$\text{Capacity drop} = -\frac{I_m}{\omega C} \cos \omega t$$

The impressed voltage must be the sum of the drop over the resistance and that over the condenser and is so shown in Fig. 48. The current leads the impressed voltage by the angle ϕ , the magnitude of which is fixed by the relative magnitudes of the reactance and resistance drops.

The three curves of Fig. 48 are shown vectorially in Fig. 49, effective values being used instead of maximum values. From this vector diagram we have

$$E^2 = (IR)^2 + \left(\frac{I}{\omega C}\right)^2,$$

or

$$I = \frac{E}{\sqrt{R^2 + \left(\frac{1}{\omega C}\right)^2}} = \frac{E}{Z} \dots \dots \dots (31)$$

and

$$\tan \phi = \frac{1}{\omega C R} = \frac{1}{\omega C R} \dots \dots \dots (32)$$

The current in the circuit, as shown in Eq. 31, evidently depends upon the frequency; its variation as the frequency is changed, is shown in Fig. 50. At very high frequency the current approaches the value E/R , the

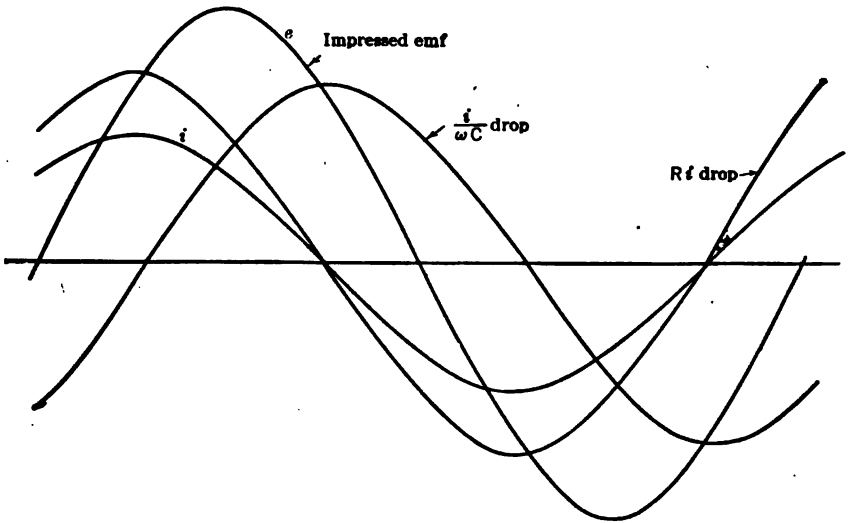

FIG. 48.—Voltages and current curves for circuit containing R and C , in series.

capacity reactance being negligible, while at zero frequency, the current is zero, the condenser being equivalent to an open circuit.

Transient Current in a Circuit Consisting of Resistance and Condenser in Series.—In general there will be a transient current when switching

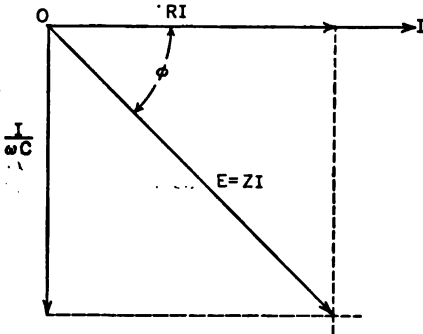

FIG. 49.—Vector diagram of voltages and current for circuit containing R and C

such a circuit to an a.c. line; the duration of the transient term is so short, however, on all commercial circuits that an oscillogram shows the current rising immediately to its proper value, this being fixed by the time on the e.m.f. cycle that the switch is closed.

Current Flow in a Circuit Having Resistance, Inductance, and Capacity in Series.—The current flowing in the circuit shown in Fig. 51 will require

three components of e.m.f., the resistance drop IR , the inductance drop $2\pi fLI$, and the capacity drop $\frac{I}{2\pi fC}$. The resistance drop is in phase with the current, the inductance drop is 90° ahead of the current

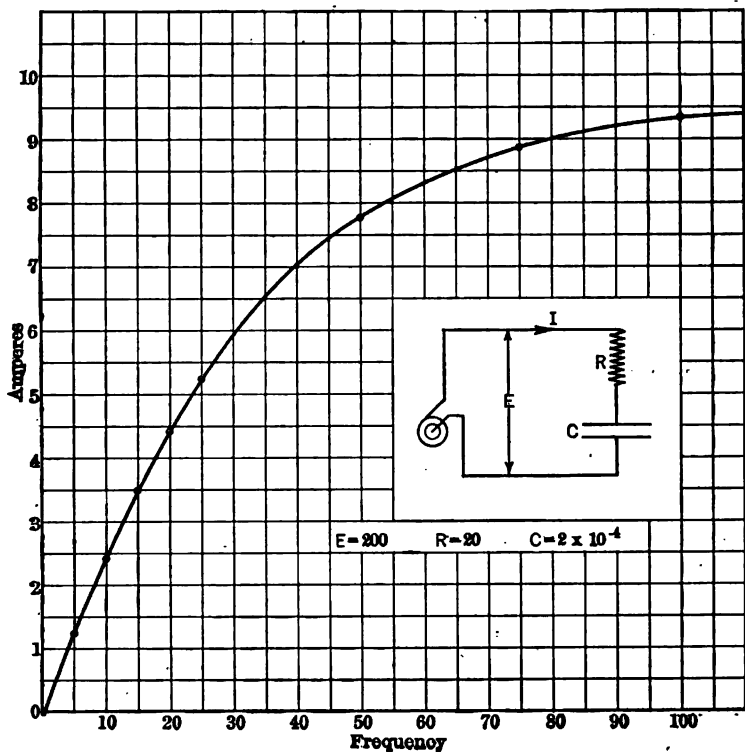

FIG. 50.—Variation of current with frequency in circuit containing R and C in series.

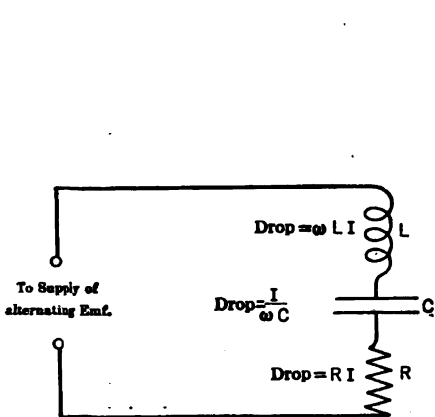

FIG. 51.

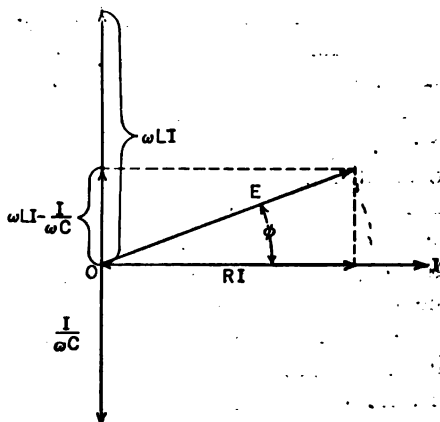

FIG. 52.

FIG. 51.—Circuit containing R , L , and C in series.

FIG. 52.—Vector diagram of voltages and current for circuit containing R , L and C in series.

and the capacity drop is 90° behind the current. These three components of the impressed e.m.f. are shown vectorially in Fig. 52. The two reactance drops evidently tend to neutralize one another.

The total reactance drop

$$= 2\pi fLI - \frac{I}{2\pi fC} \dots \dots \dots (33)$$

The resultant required impressed voltage is seen to be

$$E = I \sqrt{R^2 + \left(2\pi fL - \frac{1}{2\pi fC}\right)^2}, \dots \dots \dots (34)$$

and the magnitude of the current may be written

$$I = \frac{E}{\sqrt{R^2 + \left(\omega L - \frac{1}{\omega C}\right)^2}} = \frac{E}{Z} \dots \dots \dots (35)$$

The phase difference between impressed voltage and current is fixed by the equation

$$\cos \phi = \frac{R}{Z} \quad \text{or} \quad \tan \phi = \frac{\omega L - \frac{1}{\omega C}}{R} \dots \dots \dots (36)$$

The reactance of the circuit may either be positive or negative, according to which component of the reactance predominates. If $2\pi fL$ is greater than $\frac{1}{2\pi fC}$ the reactance is positive and the current lags, whereas if the capacity reactance is the greater, that current leads the impressed e.m.f.

The magnitude of the current will evidently depend upon the frequency and will have about the form shown in Fig. 53. At zero frequency the condenser offers infinite reactance so the current is zero; at infinitely high frequency the inductance reactance becomes so great that again the current approaches zero; at some intermediate frequency the inductance reactance just balances the capacity reactance so that *the total reactance is zero*. For this frequency the current has a maximum value, as shown for frequency f , in Fig. 53. The form of this curve could have been predicted by considering the two curves given in Figs. 38 and 50.

Resonance.—For such a circuit as shown in Fig. 51 there will always be one frequency which will give a total reactance zero; this will be true no matter what values of L and C may be chosen. At this frequency the current will be in phase with the e.m.f. and its magnitude will be a maximum, being limited only by the resistance of the circuit, $I = E/R$.

The frequency at which this occurs is called the *resonant frequency* of the circuit; it is at this frequency that most radio circuits are operated.

Unless care is exercised when performing experiments on resonance the condensers used in the circuit will be spoiled by the puncturing of the dielectric at the resonant frequency. For any frequency whatever the drop across the condenser is fixed by the relation,

$$E_c = \frac{I}{2\pi fC}$$

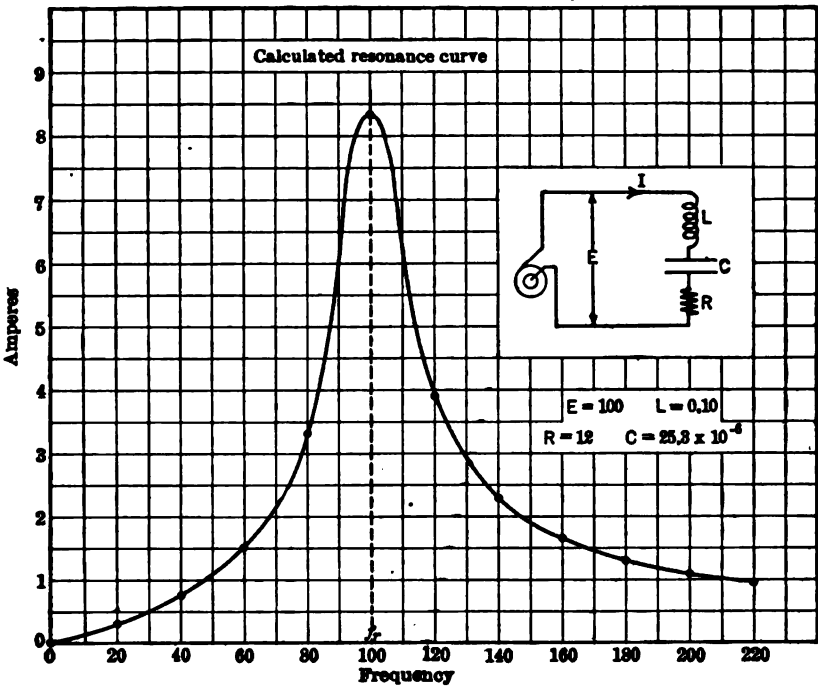

FIG. 53.—Variation of current with frequency in circuit containing *R*, *L*, and *C* in series.

If we substitute in this equation the value of the current, in terms of impressed voltage and resistance we get, at resonance,

$$E_c = E \frac{1}{2\pi fCR} \dots \dots \dots (37)$$

As the value of $\frac{1}{2\pi fCR}$ may be much greater than unity so the voltage across the condenser may be many times as great as the impressed voltage; in a certain laboratory circuit used in performing low-frequency resonance tests the drop across the condenser at resonant frequency is eighteen times as great as the impressed voltage. At this frequency the drop across the inductance is equal to that across the condenser, but this excessive voltage

across the inductance coil will generally do no harm. In radio circuits it is possible to have the drop across the inductance and condenser as much as 400 times greater than the impressed voltage.

Resonant Frequency.—A circuit is said to be resonant when the reactance is zero. Therefore we have for the resonant frequency,

$$2\pi fL = \frac{1}{2\pi fC},$$

from which we get the value of the resonant frequency

$$f = \frac{1}{2\pi\sqrt{LC}} \quad \dots \dots \dots (38)$$

In this equation L must be in henries, C in farads, and f will be in cycles per second. As the microfarad is the usual unit of capacity a more convenient form is

$$f = \frac{1000}{2\pi\sqrt{LC}}, \quad \dots \dots \dots (39)$$

C being in microfarads. In determining this frequency the separate values of L and C do not matter; the product LC is the quantity which fixes the critical frequency. This is a circuit having $L = .24$ henry and $C = 10$ microfarads will be resonant at the same frequency as one which has $L = .06$ henry and $C = 40$ microfarads.

The sharpness of the resonance curve is determined by the resistance of the circuit, the less the resistance the more sharply defined is the resonant frequency and the larger is the current at the resonant frequency. In Fig. 54 are shown the resonance curves obtained for a circuit having $L = .15$ henry and $C = 28.5$ microfarads. The one curve shows the variation of current with a circuit resistance of 5.8 ohms and the other shows the same thing after the resistance had been increased to 17.2 ohms.

In a low resistance circuit the resonance is said to be sharp and in a high resistance circuit it is said to be flat or dull.

Series Resonance with Varying Capacity—Decrement.—If the frequency impressed on the circuit of Fig. 51 is held constant and the capacity or inductance varied, resonance curves similar to those in Fig. 53 will be obtained except the variables will be different. Suppose such a curve has been obtained, as shown in Fig. 55. We shall now show how the shape of the curve depends upon the resistance and how to actually calculate the value of this resistance from the shape of the curve, provided that the value of L is known.

The quantity which is actually determined from the resonance curve is the ratio $R/2fL$, f being the resonance frequency of the circuit. This

ratio is called the *decrement* of the circuit, for reasons which will be apparent when the subject of oscillations is discussed.

Referring to Fig. 55, let C_r be the capacity which gives resonance, the current for this value of capacity being I_r . Let C_1 and C_2 be the two values of capacity, one greater than C_r and the other less than C_r , which serve to reduce the current to $I_r \div \sqrt{2}$ or $.707 I_r$. When the capacity has the value C_r , there is no effective reactance in the circuit, so we have,

$$\text{For } C = C_r, \quad I_r = \frac{E}{R}.$$

$$\text{For } C = C_2, \quad I = \frac{E}{\sqrt{R^2 + X_2^2}} = .707 I_r,$$

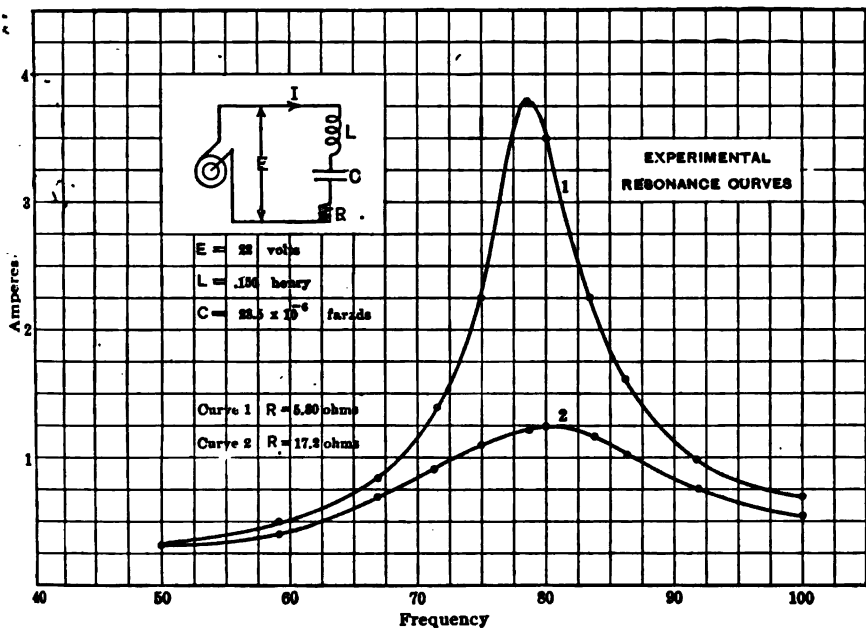

FIG. 54.—Effect of resistance on resonance curve.

which can be true only on condition that $X_2 = R$, or

$$2\pi f L - \frac{1}{2\pi f C_2} = R. \quad \dots \dots \dots (40)$$

For $C = C_1$,

$$I = \frac{E}{\sqrt{R^2 + X^2}} = .707 I_r,$$

which can be true only if

$$X_1 = R \text{ or } -\left(2\pi f L + \frac{1}{2\pi f C_1}\right) = R. \quad \dots \dots \dots (41)$$

The capacity reactance is greater than the inductance reactance for C_1 and less than the inductance reactance for C_2 , hence the reversal of the signs in front of the reactance terms in Eqs. (40) and (41).

Adding (40) and (41) we get

$$\frac{1}{2\pi f C_1} - \frac{1}{2\pi f C_2} = 2R. \quad \dots \dots \dots (42)$$

Multiplying through by $\frac{1}{2\pi f L}$, we get,

$$\frac{1}{(2\pi f)^2 LC_1} - \frac{1}{(2\pi f)^2 LC_2} = \frac{2R}{2\pi f L}$$

or

$$\frac{1}{(2\pi f)^2 L} \left(\frac{C_2 - C_1}{C_2 C_1} \right) = \frac{2R}{2\pi f L} \quad \dots \dots \dots (43)$$

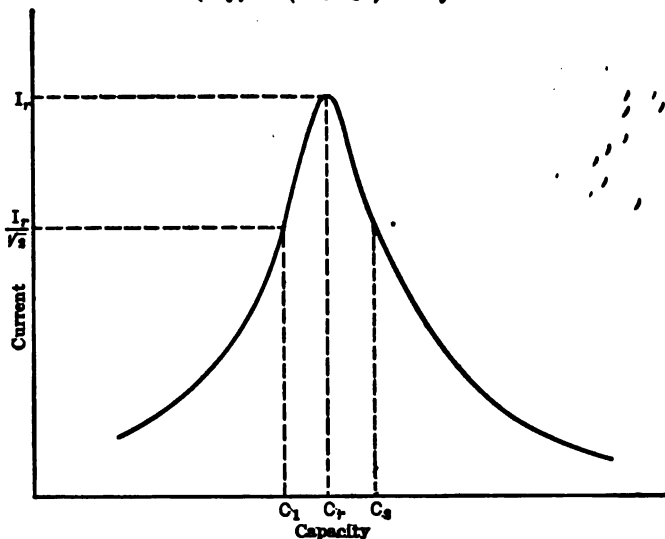

FIG. 55.—Variation of current with capacity in a resonant circuit.

Now if C_2 and C_1 do not differ from C_r very much (say 10 per cent) we may put without appreciable error

$$C_2 C_1 = C_r^2 \quad \dots \dots \dots (44)$$

This is, of course, an approximation, and is more nearly true the sharper the resonance curve. We may now put,

$$\frac{1}{(2\pi f)^2 LC_r} \left(\frac{C_2 - C_1}{C_r} \right) = \frac{2R}{2\pi f L} \quad \dots \dots \dots (45)$$

But $(2\pi f)^2 = \frac{1}{LC_r}$, as may be seen by writing the equation for resonance,

$$f = \frac{1}{2\pi \sqrt{LC_r}}$$

C_r , being the value of the capacity which gives resonance.

So (45) becomes,

$$\frac{C_2 - C_1}{C_r} = \frac{2R}{2\pi fL}$$

or

$$\frac{R}{2fL} = \frac{\pi}{2} \frac{C_2 - C_1}{C_r} \dots \dots \dots (46)$$

As an illustration of the application of this formula suppose that the resonant capacity for a certain circuit is 32 microfarads and that the values of C_2 and C_1 are 34 microfarads and 30.2 microfarads respectively. Then for this circuit the decrement, generally designated by the Greek letter δ , is

$$\delta = \frac{R}{2fL} = \frac{\pi}{2} \frac{34 - 30.2}{32} = 0.187$$

The decrement may also be calculated from a resonance curve plotted with frequencies as abscissæ as given in Fig. 56; we have derived the formula when capacity is used for abscissæ because such is generally the case in radio measurements. If however, frequency, is used as abscissæ, the frequency having been varied in getting the resonance curve, L and C having been maintained constant, the derivation of δ from the half energy points of the resonance curve is as follows:

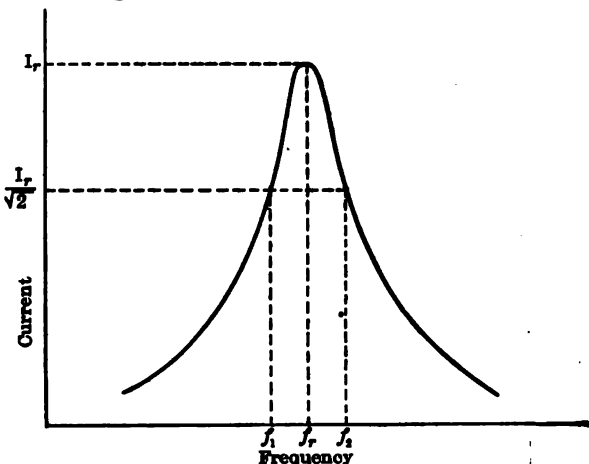

FIG. 56.—Variation of current with frequency in a resonant circuit.

$$2\pi f_1 L - \frac{1}{2\pi f_1 C} = -R$$

$$2\pi f_2 L - \frac{1}{2\pi f_2 C} = R$$

To eliminate C from these two equations, multiply them by $2\pi f_1 C$ and $2\pi f_2 C$ respectively and get the two equations

$$(2\pi f_1)^2 LC - 1 = -R2\pi f_1 C$$

$$(2\pi f_2)^2 LC - 1 = R2\pi f_2 C$$

Put these in the forms

$$C\{(2\pi f_1)^2 L + 2\pi f_1 R\} = 1,$$

$$C\{(2\pi f_2)^2 L - 2\pi f_2 R\} = 1.$$

Combining

$$(2\pi f_1)^2 L + 2\pi f_1 R = (2\pi f_2)^2 L - 2\pi f_2 R,$$

$$R(2\pi f_1 + 2\pi f_2) = L\{(2\pi f_2)^2 - (2\pi f_1)^2\}.$$

So

$$\frac{R}{2L} = \frac{2\pi(f_2^2 - f_1^2)}{2(f_2 + f_1)} = \pi(f_2 - f_1).$$

Dividing by f_r , the resonant frequency,

$$\frac{R}{2f_r L} = \delta = \pi \frac{f_2 - f_1}{f_r} \dots \dots \dots (47)$$

For a given circuit $\frac{f_2 - f_1}{f_r}$ is approximately equal to $\frac{1}{2} \frac{C_2 - C_1}{C_r}$. This follows from the relation between frequency and capacity; to produce a certain small percentage change in the natural frequency of a circuit it is necessary to change the capacity of the circuit by twice this amount, the frequency varying not with the capacity, but with the square root of the capacity.

Flow of Current in Parallel Circuits and Relation of Line Current to Branch Currents.—When a circuit consists of two or more branches in parallel the line current cannot be obtained by calculating the branch currents and adding them arithmetically as is done in continuous current circuits, because of the difference in phase of the various branch currents. The line current, instead of being equal to the arithmetical sum of the branch currents, may be even smaller than either of the branch currents

and, in fact, is so in many radio circuits. It is necessary to calculate not only the magnitude of the different branch currents, but also their phase; these branch currents are then added *vectorially* to give the line current.

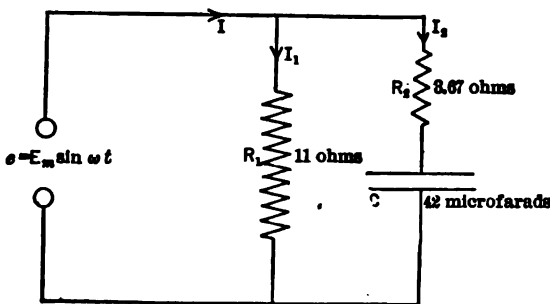

FIG. 57.—Parallel circuits.

Suppose a circuit made up as shown in Fig. 57, the current I_1 being 10 amperes, in phase with the line voltage and the current I_2 being 15 amperes, leading the line voltage by 60° ; the line current will be the

vector sum of 10 and 15 as shown in Fig. 58. It proves to be 21.8 amperes. The angle of the lead is found by the relation of the reactive and active components of the line current (the active component of a current is that component which is in phase with the voltage and the reactive component is that which is 90° out of phase with the voltage). I_1 has no reactive component and so contributes 10 amperes to the active component of the line current only; I_2 has a reactive component equal to $15 \sin 60^\circ$ or 13 amperes, and an active component of $15 \cos 60^\circ$ or 7.5 amperes. The total active line current is therefore 17.5 amperes and the reactive component is 13 amperes. The angle of lead of the line current is then $\tan^{-1} 13/17.5$ or 36.6° .

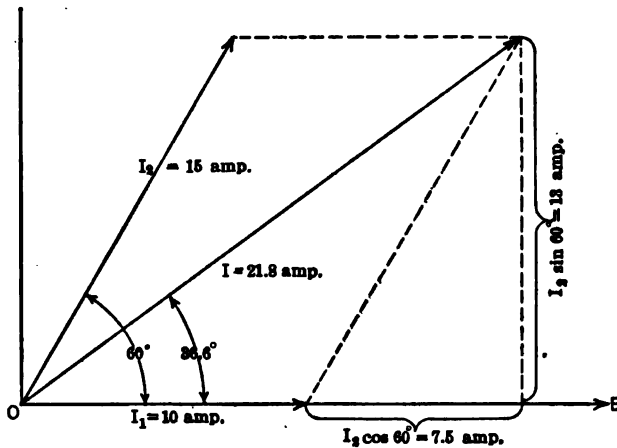

FIG. 58.—Vector diagram of currents in the parallel circuit shown in Fig. 57.

If the impressed voltage is 110 volts the impedance of the branched circuit is equal to $110/21.8$ or 5.95 ohms.

The equivalent resistance is $Z \cos \phi = 5.95 \cos 36.6^\circ = 3.82$ ohms.

The equivalent reactance is $Z \sin \phi = 5.95 \sin 36.6^\circ = 3.56$ ohms.

The equivalent series condenser of the combined circuit is found by putting the reactance equal to $\frac{1}{2\pi f C'}$. If the frequency of the supply is 60 cycles this gives

$$\frac{1}{2\pi f C'} = 3.56 \text{ ohms, or } C' = 74.4 \text{ microfarads.}$$

Hence the branched circuit shown in Fig. 57 is exactly equivalent to the single circuit shown in Fig. 59, for the frequency assumed; for a different frequency other values of equivalent resistance and equivalent capacity would be obtained. A more detailed analysis of a branched circuit, using complex quantities, is given elsewhere.

In case the branched circuit is more complex than that given in Fig. 57, such as that given in Fig. 60, the branched part must first be replaced by its equivalent single circuit, calculated as shown for Fig. 57; the resist-

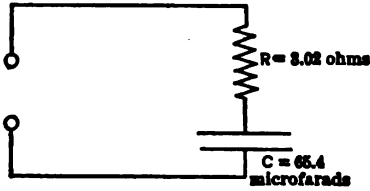

FIG. 59.—Simple series circuit equivalent to parallel circuit of Fig. 57.

ance and reactance of this equivalent circuit must then be added to the resistance and reactance of R_1 and L_1 . By vectorially combining this total resistance and reactance the impedance of the simple equivalent circuit is obtained.

Impedance of a Circuit Made Up of L, R, and C, in Series.—The reactance of this circuit is calculated by finding the sum of the inductance

and capacity reactances at all the frequencies necessary; the equivalent resistance of this circuit is independent of frequency and equal at all frequencies to the actual resistance, R . The several quantities are shown

in the form of curves in Fig. 61. The reactance, $\frac{1}{2\pi fC}$, is shown negative; the total reactance, X , is negative at frequencies lower than the resonant value and positive above this value. The impedance is positive for all values of frequency, having its minimum value when the total reactance X , is zero, then being equal to R .

The current leads the voltage for frequencies lower than the resonant value and lags behind the voltage for higher frequencies.

Impedance of a Branched Circuit, Having L and R in One Branch and C and R in the Other.—The simplest way

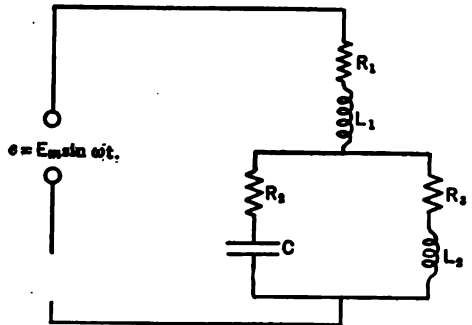

FIG. 60.—Series-Multiple circuit.

of comprehending the impedance of this complex path, Fig. 62, is to calculate for each value of frequency, the magnitude and phase of the current in each branch. The active and reactive components of the two branch currents are then calculated. The active component of line current is found by adding the two active branch currents and the reactive component of the line current is found by adding the reactive branch currents. These additions are to be algebraic; in the case of the active current the algebraic sum is the arithmetic sum but the reactive current in the line is the *difference* of the reactive currents of the branches.

In Fig. 63 is shown the vector diagram for frequency above the resonant frequency of the circuit; the line current in this case leads the voltage

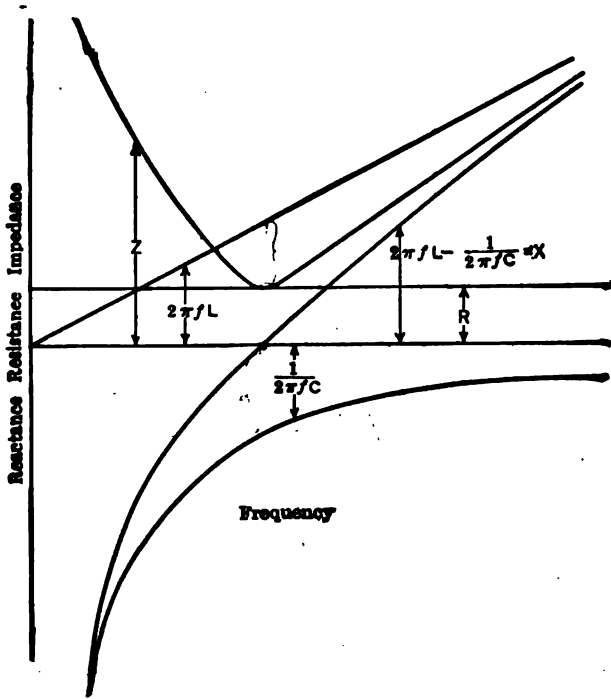

FIG. 61.—Variation of reactance, resistance and impedance with frequency in a circuit containing L , R , and C in series.

so the equivalent simple circuit would consist of a condenser in series with a resistance, the two having such values that when the simple circuit was connected to a line voltage E , the current flowing would be equal, in magnitude and phase, to I of Fig. 63.

In Fig. 64 is shown the condition when impressed frequency is so adjusted that the reactive currents in each branch neutralize each other; in this case the simple circuit would consist of a resistance only. The resistance of the simple circuit would, in general, be many times as great as the resistance in the actual branched circuit.

In Fig. 65 the frequency is supposed lower than the resonant frequency, the current taken by the inductive branch being greater than that taken

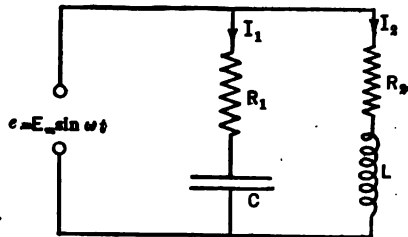

FIG. 62.—Branched circuit, having L and R in one branch and C and R in the other.

by the capacity branch; the equivalent simple circuit for this case would consist of a resistance in series with an inductance.

The above simple analysis shows that the branched circuit of Fig. 62 may be represented by a single circuit, but the constants of this simple circuit must be made to vary as the frequency is varied.

The equivalent R may be obtained by calculating the I^2R loss in each branch and adding to give the total loss in the circuit; this total loss,

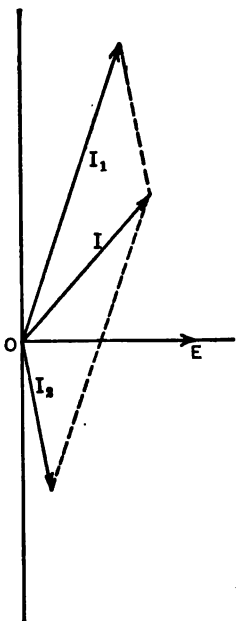

FIG. 63.

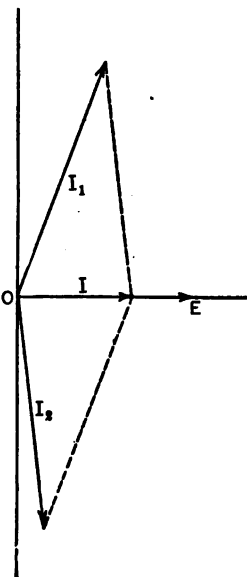

FIG. 64.

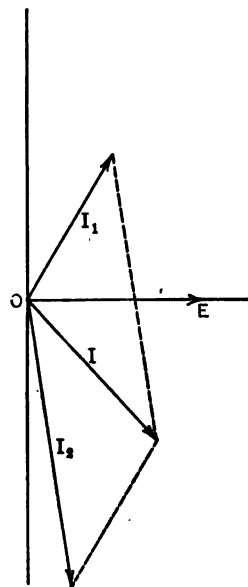

FIG. 65.

FIG. 63.—Vector diagram for circuit of Fig. 62, line current leading.

FIG. 64.—Vector diagram for circuit of Fig. 62, line current in phase with impressed e.m.f.

FIG. 65.—Vector diagram for circuit of Fig. 62, line current lagging.

divided by the square of the line current (obtained vectorially as shown in Figs. 63–65), gives the equivalent resistance of the combination.

The equivalent inductance or capacity is obtained by calculating the reactive component of the impressed e.m.f.; this equals $E \sin \phi$ where E is the value of the impressed voltage and ϕ is the angle between the impressed voltage and the line current. This value of e.m.f., $E \sin \phi$, is put equal to $2\pi f L' I$, where L' is the equivalent inductance and I is the line current.

In case the line current is leading $\sin \phi$ is negative and the equivalent inductance would be negative. In this case the reactive component of the impressed voltage, $E \sin \phi$, is put equal to $\frac{1}{2\pi f C'}$, where C' is the equivalent series capacity of the circuit.

The circuit is analyzed exactly most easily by the use of complex algebra, a method of treatment explained in all standard texts on alternating currents.

Let $Z_1 =$ impedance of branch 1 $= R_L + j\omega L$;

$Z_2 =$ impedance of branch 2 $= R_C - j \frac{1}{\omega C}$;

$Z =$ impedance of the joint path.

$$\frac{1}{Z} = \frac{1}{Z_1} + \frac{1}{Z_2} = \frac{1}{R_L + j\omega L} + \frac{1}{R_C - j \frac{1}{\omega C}}$$

$$= \frac{\left(R_C - j \frac{1}{\omega C}\right) + (R_L + j\omega L)}{(R_L + j\omega L)\left(R_C - j \frac{1}{\omega C}\right)}$$

Hence
$$Z = \frac{(R_L + j\omega L)\left(R_C - j \frac{1}{\omega C}\right)}{(R_L + R_C) + j\left(\omega L - \frac{1}{\omega C}\right)}$$

Rationalize by multiplying numerator and denominator by

$$(R_L + R_C) - j\left(\omega L - \frac{1}{\omega C}\right).$$

Collecting terms we have

$$Z = \frac{R_C R_L (R_C + R_L) + R_C (\omega L)^2 + R_L \frac{1}{(\omega C)^2} + j \left[R_C^2 \omega L - R_L^2 \frac{1}{\omega C} - \frac{L}{C} \left(\omega L - \frac{1}{\omega C} \right) \right]}{(R_L + R_C)^2 + \left(\omega L - \frac{1}{\omega C} \right)^2}$$

Of this complex impedance the real part is the effective resistance of the branched circuit and the imaginary part is the reactance, or $\omega L'$, where L' is the effective inductance.

So

$$R' = \frac{R_c R_L (R_c + R_L) + R_c (\omega L)^2 + R_L \frac{1}{(\omega C)^2}}{(R_L + R_c)^2 + \left(\omega L - \frac{1}{\omega C}\right)^2} \dots \dots \dots (48)$$

$$L' = \frac{R_c^2 L - R_L^2 \frac{1}{\omega^2 C} - \frac{L}{C} \left(L - \frac{1}{\omega^2 C}\right)}{(R_L + R_c)^2 + \left(\omega L - \frac{1}{\omega C}\right)^2} \dots \dots \dots (49)$$

In case the resistance of the inductance is large compared to that of the condenser, Eqs. (48) and (49) may be simplified to the approximately correct forms

$$R' = \frac{R}{m^2 R^2 \frac{C}{L} + (m^2 - 1)^2} \dots \dots \dots (50)$$

$$L' = -L \frac{R^2 \frac{C}{L} + (m^2 - 1)^2}{m^2 R^2 \frac{C}{L} + (m^2 - 1)^2}, \dots \dots \dots (51)$$

where

 R' = equivalent series resistance; L' = equivalent series inductance;

R = total actual resistance in the circuit, that is, resistance of the inductive branch plus that of the capacity branch;

C = actual capacity of the capacity branch;

L = actual inductance of the inductive branch;

m = ratio of the impressed frequency to the resonant frequency of the circuit = $2\pi f \sqrt{LC}$.

In case L' comes out a negative quantity it is converted to its equivalent series capacity by the relation

$$C' = 1/(2\pi f)^2 (-L'). \dots \dots \dots (52)$$

An interesting condition obtains in a circuit having parallel resonance. Thus suppose that the values of L and C and the frequency of supply for the circuit of Fig. 66 have been so adjusted that for a voltage impressed across $A-B$ the circuit shows no reactance; the power factor is unity and the circuit shows resistance only.

If the supply voltage is impressed across any other two points in the circuit, the circuit will be in resonance for these points also; if, for example, the voltage is impressed across points $C-D$. the circuit will show resistance only.

The resistance will not be the same when measured between points $C-D$ as it is for the points $A-B$. It may be proved that the resistance between any two points in the circuit is nearly proportional to the square of the reactance included between the two points, in either branch. The reactance in each branch of the parallel circuit will be the same, no matter where the two points are taken, but the reactance will be inductive in one branch and capacitive in the other.

Fig. 67 illustrates another combination of inductance and condensers; such a circuit is used in one of the common forms of radio telephone apparatus. The frequency of current in the closed circuit is fixed by the resonant period of this circuit, that is $f = \frac{1}{2\pi\sqrt{LC}}$ where $C = \frac{C_1 C_2}{C_1 + C_2}$. The alternating current supply for the circuit is furnished across the condenser

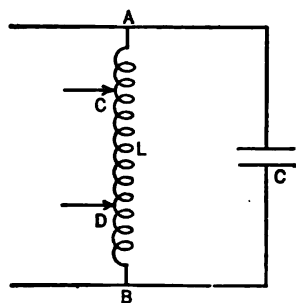

FIG. 66.

FIG. 66.—Resonant multiple circuit.

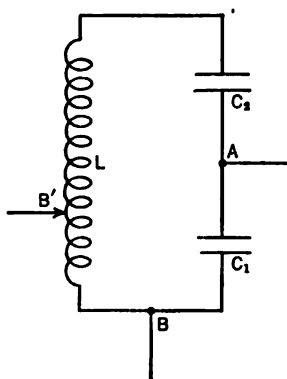

FIG. 67.

FIG. 67.—Resonant multiple circuit used in a radio-telephone set.

C_1 , and the power factor of this circuit (i.e., between points A and B) is unity; the impedance offered to the supply circuit is resistance only. If the point B is moved around the circuit so as to include part of the inductance L in either path, as shown at B' , the impedance between the two points A and B' would still be resistance only.

It is often desired in radio circuits to alter the impedance of the circuit to which the power is supplied. Thus in certain vacuum-tube circuits a resonant circuit (as shown in Fig. 67) is used as load for the tube output and, to get the maximum output from the tube, the circuit must offer resistance only (no reactance), and this resistance must have a proper value. Evidently such a circuit as that shown in Fig. 67 offers such possibility; by properly adjusting the position of B' the desired resistance will be obtained.

Varying the value of C_1 , however, has the disadvantage of changing also the frequency of the circuit. If C_1 is held constant and the point B is moved along the inductance, the effective resistance between points A and B will vary while the frequency is maintained practically constant. Such a connection scheme is generally used in practice.

To illustrate this idea with experimental data a simple test was performed. An inductance coil, having a tap near its center, was connected

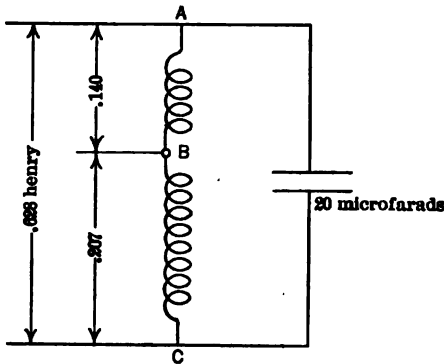

FIG. 68.—Experimental resonant multiple circuit similar to that of Fig. 67.

to a condenser as shown in Fig. 68 and resonant frequency was impressed across $A-C$. The values of inductance and capacity were about as shown in the diagram, the resistance of the coil being about 10.8 ohms. A watt-meter, voltmeter, and ammeter were used to measure the input; the frequency was held constant at 45 cycles, which is the frequency to give resonance for $L = .628$ henry and $C = 20$ microfarads. The effective resistance was calculated by divid-

ing the wattmeter reading by the square of the ammeter reading. The results obtained are tabulated below:

	Volts.	Amperes.	Watts.	Effective Resistance, Ohms.
Terminals $C-A$	105	.050	5	2000
Terminals $C-B$	105	.145	14.8	705
Terminals $B-A$	100	.170	16.6	575

These values of resistance are nearly proportional to the square of the value of reactance between the respective terminals; better results cannot be obtained by this method, because the current taken by a condenser exaggerates the non-sinusoidal form of the impressed voltage and so may differ quite appreciably from the true sine form. In parallel resonance the very small minimum line current obtained is a result of the inductive and capacitive currents of the two branches neutralizing each other; if, however, the two currents are not of the same form, it is evident that the neutralization cannot be very complete and the line current at resonance will not be as small as it should normally be.

A case of this kind is shown clearly in the oscillogram of Fig. 69; the generator supplying the power was of an ordinary commercial type, having however, a rather smaller air gap than is usual. The inductance and ca-

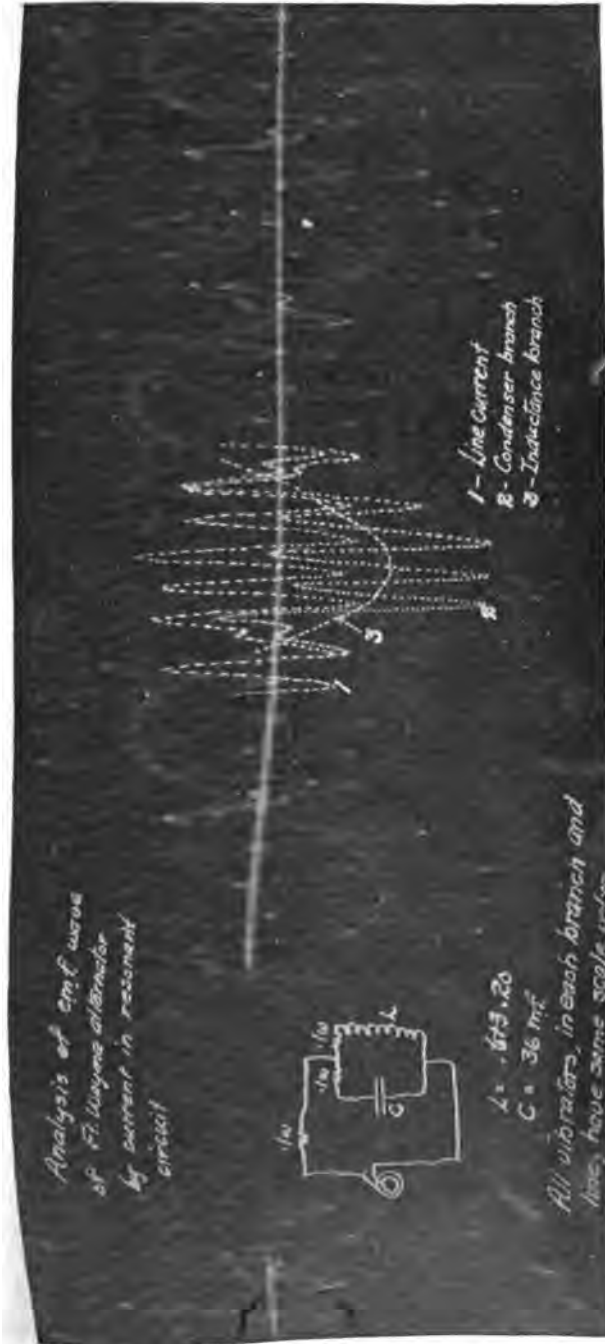

FIG. 69.—Oscillogram of currents in a multiple resonant circuit, showing effect of complex wave of e.m.f.

capacity were connected in parallel and the impressed frequency was varied until the line current showed a minimum value. The form and phase of the currents in the two branches of the circuit are shown well on the film, and it is at once evident that the great difference in form of the two currents would prevent the resonance phenomena being very marked. Probably 50 per cent of the current flowing in the condenser circuit is of some frequency much higher than that for which the circuit was resonant and at least this much current would persist in the supply line no matter how carefully the circuit was adjusted for resonance.

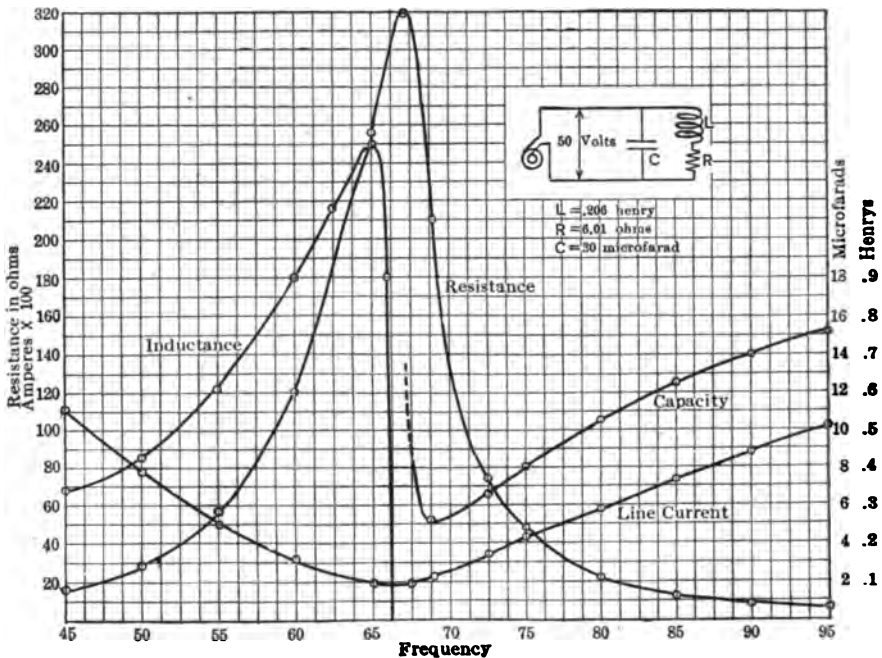

FIG. 70.—Reactance and resistance curves for a parallel resonant circuit having low resistance.

This question of upper harmonics is often of much importance in the operation of radio apparatus; more specific mention of the occurrences will be made when discussing certain types of radio generators.

It is possible to move points *A* and *B'* (Fig. 67) to such a position that there is no reactance in either path. In this case we have a maximum possible line current (for a given impressed voltage) and the resistance of the combination is a minimum. It is equal to the resistance of one path divided by two, if the two paths have equal resistances; if not it is equal to the reciprocal of the sum of the reciprocals of the resistances in the separate paths. In Figs. 70 and 71 are some experimental curves showing

the characteristics of parallel resonance; they were obtained by ammeter, voltmeter, and wattmeter readings, frequency being varied and impressed voltage being held constant. The equivalent resistance was obtained directly by dividing the wattmeter reading by the squared value of the line ammeter reading; the equivalent inductance or capacity was found after calculating the reactive component of the impressed voltage and knowing the line current from the ammeter reading. The alternator used had a very pure sine wave of e.m.f. compared to that given by the average machine.

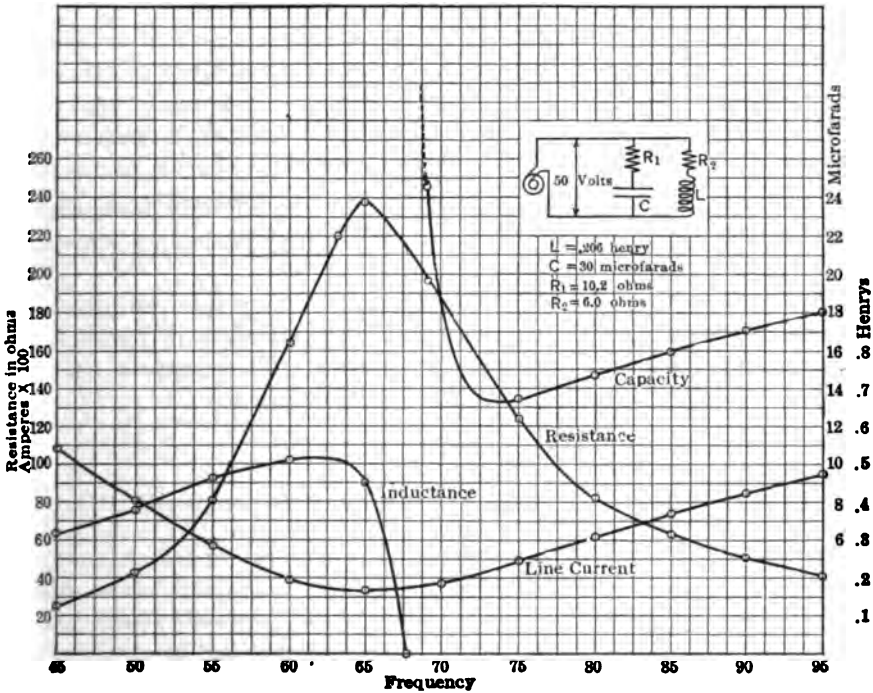

FIG. 71.—Effect of increasing the resistance in a parallel resonant circuit; compare with curves of Fig. 70.

A rather extraordinary effect is seen in these curves; the equivalent series resistance at resonance is higher the lower the actual resistance of the circuit. Thus in the first case where the actual resistance was 6 ohms the equivalent resistance has a maximum value of 320 ohms; in the second case where the actual resistance has been increased to 16 ohms the maximum value of R is only 240 ohms. In neither case is the equivalent resistance nearly as great as calculation by Eqs. (48) and (49) would indicate; the reason for this discrepancy lies in the method of measurement which involves an error depending upon the non-sinusoidal form of the voltage impressed on the circuit as outlined above.

It will be noticed from the curves given in Figs. 70 and 71 that the effective inductance of a coil may be increased by putting a condenser in parallel with the coil; the equivalent resistance of the coil also increases and this increase rapidly grows larger as the amount of capacity shunting the coil is increased.

For the frequencies far removed from the resonant frequency of the circuit (so that $(m^2 - 1)$ is large compared to $m^2 R^2 \frac{C}{L}$) we get rather simple formulæ for the equivalent inductance and resistance of the coil. Formulæ (50) and (51) in this case reduce to the forms

$$R' = \frac{R}{(m^2 - 1)^2} \dots \dots \dots (52)$$

$$L' = \frac{L}{m^2 - 1} \dots \dots \dots (53)$$

Inspection of these equations shows that the effective resistance of the circuit rises more rapidly than does the effective inductance, especially as the resonant frequency is approached.

A Peculiar Case of Parallel Resonance.—A very interesting case of resonance occurs if, with an inductance and condenser in parallel, the resistances in each path are properly adjusted. Thus suppose that the resistance in the two paths are equal and also equal to

$$\sqrt{\frac{L}{C}}$$

that is,

$$R_L = R_C = \sqrt{\frac{L}{C}}$$

By inserting this condition in Eqs. (48) and (49) *it will be found that the reactance of the circuit is zero for all frequencies and that the resistance is constant for all frequencies and equal to the resistance of each path.*

Resonant Frequency of Parallel Circuits.—If we define the resonant frequency of a parallel circuit as that frequency which makes the reactance of the circuit zero, thus making the power factor of the circuit unity, we find the resonant frequency by using Eq. (49), putting the numerator equal to zero. This gives the equation

$$R_C^2 L - R_L^2 \frac{1}{\omega^2 C} - \frac{L}{C} \left(L - \frac{1}{\omega^2 C} \right) = 0$$

or

$$\frac{1}{\omega^2} \left(\frac{L}{C^2} - \frac{R_L}{C} \right) = \frac{L^2}{C} - R_C^2 L,$$

from which we get,

$$\omega = \sqrt{\frac{L - R_L^2 C}{L^2 C - R_C^2 C^2 L}} \dots \dots \dots (54)$$

In case the resistance of the condenser arm is negligible a simpler form is obtained,

$$\omega = \sqrt{\frac{1}{LC} - \frac{R^2}{L^2}} \dots \dots \dots (55)$$

It is to be noted that in parallel circuits the resistances in the circuit affect to some extent the resonant frequency of the circuit, whereas in the series circuit the resonant frequency is independent of the resistance.

The condition for resonance in parallel circuits (unity power factor) will in general not be the frequency which gives minimum line current. In case we had defined resonance as that condition which gave minimum line current, formulæ somewhat different from Eqs. (54) and (55) would have been obtained.

Coupling of Various Kinds—Coefficient of Coupling.—When two circuits are so placed or interconnected that energy may be transferred from one to the other they are said to be coupled. There are three types of

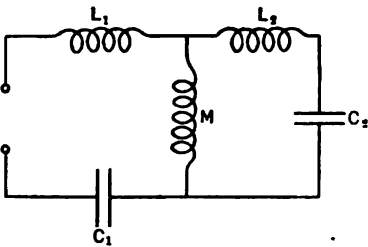

FIG. 72.—Direct coupling.

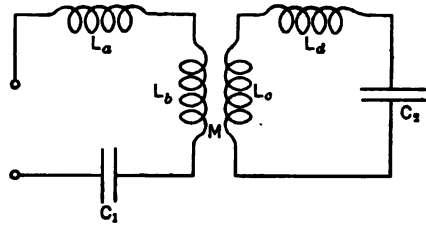

FIG. 73.—Inductive coupling.

coupling, resistance, inductance, or condenser coupling. In the first (practically never used) that part of the network which is common to the two circuits is a resistance; in the second, part of the magnetic field generated by currents in the network is common to both circuits; in the third, a part of the electro-static field set up in the network is common to both circuits. The coupling which uses the magnetic field is called inductive or magnetic coupling, and that which uses the electric field is called capacitive or static coupling. The magnetic coupling may be through an inductance common to both circuits called *direct*, or it may be through a mutual inductance in which case it is generally called *inductive* coupling.

The three principal types of coupling are shown in Figs. 72, 73, and 74, that of Fig. 72 being direct, that of Fig. 73 being inductive, and that of Fig. 74 being capacitive.

The extent to which circuits are coupled is given quantitatively by the *coupling coefficient* or *coefficient of coupling*. This is defined as the ratio of the common reactance of the two circuits to the square root of the reactances (of similar kind to that giving the coupling) of the two circuits.

Thus if X_m = reactance common to both circuits;
 X_1 = reactance of circuit 1;
 X_2 = reactance of circuit 2;
 k = coupling coefficient.

$$k = \frac{X_m}{\sqrt{X_1 X_2}} \dots \dots \dots (56)$$

In Fig. 72 the total reactance of circuit 1 is $\omega(L_1 + M)$, that of circuit 2 is $\omega(L_2 + M)$, and the common reactance is ωM . Therefore

$$k = \frac{\omega M}{\sqrt{\omega(L_1 + M)\omega(L_2 + M)}} = \frac{M}{\sqrt{(L_1 + M)(L_2 + M)}} \dots (57)$$

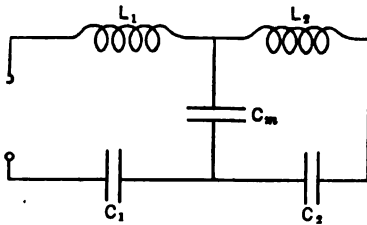

FIG. 74.—Capacitive coupling.

In Fig. 73 the total inductance of circuit 1 is indicated by $L_a + L_b$; part of this is in inductive relation to circuit 2 and part is not. Similarly the inductance of the second circuit consists of two parts L_c and L_d , one part magnetically coupled to circuit 1 and the other part not so coupled. The common reactance is ωM . Hence for this case we have,

$$k = \frac{\omega M}{\sqrt{\omega(L_a + L_b)\omega(L_c + L_d)}} = \frac{M}{\sqrt{(L_a + L_b)(L_c + L_d)}} \dots (58)$$

The inductively coupled circuit of Fig. 73 can always be considered as a direct-coupled circuit after the proper transformations have been made. The inductance of circuit 2 must be decreased in the ratio L_b/L_c and the capacity of circuit 2 must be increased in the ratio L_c/L_b . This transformation of the inductance and capacity of circuit 2 leaves the *oscillation constant* (LC) the same as it was with the original values of L and C .

The M of the equivalent circuit is obtained by multiplying the actual value of M by the ratio $\sqrt{L_c/L_b}$. Let us call these new values M' , L'_c , L'_a , and C'_2 . The inductively coupled circuit is now replaced by the direct-coupled circuit similar to that of Fig. 72. For the L of Fig. 72 we use $(L_a + L_b) - M'$ and for the L_2 of Fig. 72 we use $(L'_c - L'_a) - M'$.

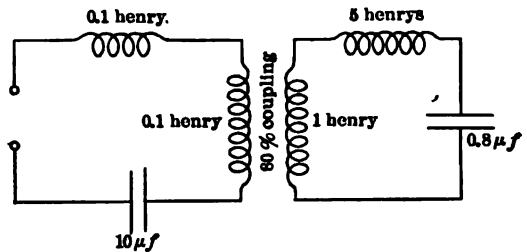

FIG. 75.—Inductively coupled circuits.

An actual inductively coupled circuit is shown in Fig. 75; the coefficient of coupling of the *two coils of the transformer* is 80 per cent, or

$$M = 0.8\sqrt{1 \times 0.1} = 0.253 \text{ henry.}$$

In Fig. 76 the inductances of the second circuit have been decreased in the ratio 0.1/1 and the capacity has been increased in the ratio 1/0.1. The coefficient of coupling must remain as it was for Fig. 75, so we decrease M in the ratio $\sqrt{\frac{0.1}{1}}$, giving it a value of 0.08 henry.

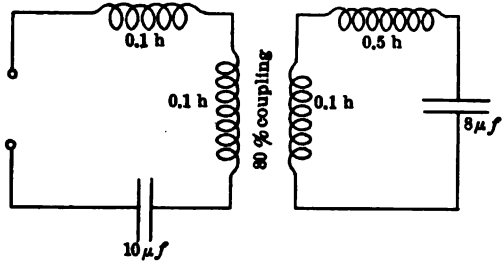

FIG. 76.—Circuit of Fig. 75 reduced to an equivalent 1:1 ratio circuit.

The direct-coupled circuit, which is the exact equivalent of the inductively coupled circuit of Fig. 76, is now given in Fig. 77. The total L of circuit 1 is the same as that of Fig. 76, 0.08 henry being coupled 100 per cent to circuit 2; similarly the total inductance of circuit 2 is the same as it is in Fig. 76.

The coefficient of coupling of the circuit of Fig. 77 is

$$k = \frac{0.08}{\sqrt{0.2 \times 0.6}} = 0.232,$$

and for the actual inductively coupled circuit of Fig. 75 it is

$$k = \frac{0.253}{\sqrt{0.2 \times 6.0}} = 0.232,$$

which is just the same as for the substituted direct coupled circuit.

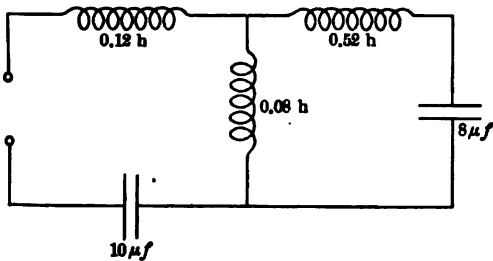

FIG. 77.—Direct-coupled circuit equivalent to inductively coupled circuit of Fig. 76.

It is possible to replace an inductively coupled circuit by one directly coupled without making the transformations explained above. Calling the total inductance in primary and secondary of the inductively coupled circuit L_3 and L_4 respectively, and the mutual inductance M , then the direct-coupled circuit is written

down at once as shown in Fig. 72 by making $L_1 = L_3 - M$ and $L_2 = L_4 - M$.

The same values of M , C_1 and C_2 are used in the direct-coupled circuit as in the inductively coupled circuit.¹ The justification for making the change from one type of circuit to the other may be seen upon writing the equations for the reactive voltages of the two circuits of Figs. 72 and 73. For Fig. 72 we have,

$$\omega L_1 I_1 - \frac{I_1}{\omega C_1} + \omega M(I_1 - I_2) = 0, \quad \dots \dots \dots (59)$$

and

$$\omega L_2 I_2 - \frac{I_2}{\omega C_2} + \omega M(I_2 - I_1) = 0. \quad \dots \dots \dots (60)$$

For the circuit shown in Fig. 73 we may put $L_a + L_b = L_3$ and $L_c + L_d = L_4$; the reactive voltages for these circuits then become,

$$\omega L_3 I_1 - \frac{I_1}{\omega C_1} - \omega M I_2 = 0, \quad \dots \dots \dots (61)$$

and

$$\omega L_4 I_2 - \frac{I_2}{\omega C_2} - \omega M I_1 = 0. \quad \dots \dots \dots (62)$$

Put $L_3 = L_1 + M$ and $L_4 = L_2 + M$ and these equations become

$$\omega(L_1 + M) I_1 - \frac{I_1}{\omega C_1} - \omega M I_2 = 0, \quad \dots \dots \dots (63)$$

and

$$\omega(L_2 + M) I_2 - \frac{I_2}{\omega C_2} - \omega M I_1 = 0. \quad \dots \dots \dots (64)$$

By collecting terms these may be changed into the forms,

$$\omega L_1 I_1 - \frac{I_1}{\omega C_1} + \omega M(I_1 - I_2) = 0, \quad \dots \dots \dots (65)$$

and

$$\omega L_2 I_2 - \frac{I_2}{\omega C_2} + \omega M(I_2 - I_1) = 0. \quad \dots \dots \dots (66)$$

But these equations, which are for an inductively coupled circuit, are identical with Eqs. (59) and (60), which are for the directly coupled circuit.

The author does not believe that this method is as satisfactory a one as that using transformed L and C in the secondary because of certain ambiguities which may arise. As an illustration of the cases in which the method works out all right we take Fig. 78. For the L_1 of Fig. 72 we must put $0.2 - 0.1 = 0.1$ henry and for L_2 of Fig. 72 we put $0.4 - 0.1 = 0.3$ henry. M , C_1 and C_2 remain as in Fig. 78. The equivalent directly coupled circuit is given in Fig. 79; it is electrically equivalent to Fig. 78.

¹ See Bulletin 74 of the Bureau of Standards, p. 50.

Now suppose the circuit of Fig. 75 to be treated in this manner; for L_1 we obtained $0.2 - 0.253 = -0.053$ henry. This means that instead of putting in an inductance for the L_1 of Fig. 72 we must put a condenser, the capacity of which is such that its reactance is equal, in magnitude, to that given by 0.053 henry of inductance.

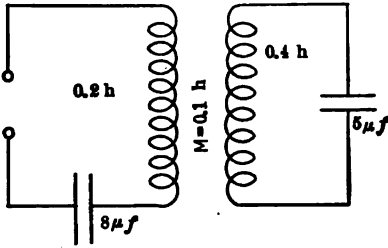

FIG. 78.

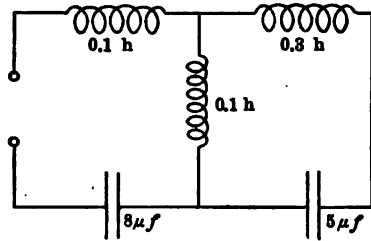

FIG. 79.

FIG. 78.—Inductively coupled circuit.

FIG. 79.—Direct-coupled circuit equivalent to circuit of Fig. 78.

For the circuit shown in Fig. 74, we get the coupling coefficient from Eq. (56) in the following manner.¹

$$\text{Mutual capacity reactance} = \frac{1}{\omega C_m}$$

$$\text{Capacity reactance of circuit 1} = \frac{1}{\omega C_1} + \frac{1}{\omega C_m} = \frac{1}{\omega C_a'}$$

in which

$$C_a = \frac{1}{\frac{1}{C_1} + \frac{1}{C_m}}$$

$$\text{Capacity reactance of circuit 2} = \frac{1}{\omega C_2} + \frac{1}{\omega C_m} = \frac{1}{\omega C_b'}$$

in which

$$C_b = \frac{1}{\frac{1}{C_2} + \frac{1}{C_m}}$$

Hence Eq. (56) becomes for this case,

$$k = \frac{\frac{1}{\omega C_m}}{\sqrt{\frac{1}{\omega C_a} + \frac{1}{\omega C_b}}} = \frac{\sqrt{C_a C_b}}{C_m} \dots \dots \dots (67)$$

¹For more complete analysis of capacitively coupled circuits and comparison of capacitive and inductive coupling see Cohen, "Electrostatically coupled circuits," Proc. I. R. E., Vol. 8, No. 5, Oct., 1920.

A rather more complicated case of static coupling is given in Fig. 80; in this case the application of Eq. (56) results in the formula ¹

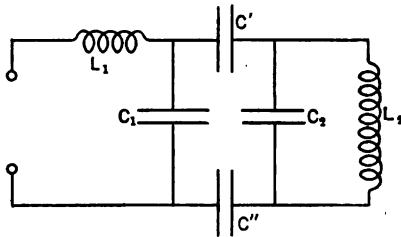

$$k = \frac{C_3}{\sqrt{(C_1 + C_3)(C_2 + C_3)}}, \dots (68)$$

in which

$$C_3 = \frac{C' C''}{C' + C''}$$

FIG. 80.—Complex capacitive coupling.

In certain radio receiving sets combined capacitive and inductive

couplings are used, as indicated in Fig. 81, in this case the coefficient of magnetic coupling and that of static coupling are calculated separately, and the actual coefficient of coupling is the sum or difference of these two, according as the e.m.f.'s induced in circuit 2 through the two types of coupling are in phase or 180° out of phase with each other.

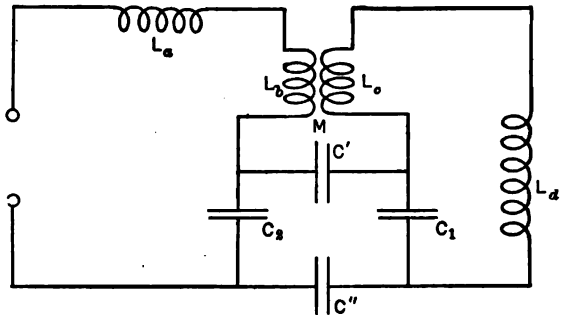

FIG. 81.—Combined capacitive and inductive coupling.

In another coupling scheme (shown in Fig. 82) a so-called link circuit, untuned, is used to connect the other two circuits. In this case the coupling between circuits 1 and 2 is obtained by calculating the coupling of circuits 1 and 3 and then that of 3 and 2.

$$k_{1-3} = \frac{M_{1-2}}{\sqrt{L_1(L_2 + L_3)'}}$$

$$k_{3-2} = \frac{M_{3-4}}{\sqrt{L_4(L_2 + L_3)'}}$$

Then

$$k_{1-2} = k_{1-3} \times k_{3-2} = \frac{M_{1-2} \times M_{3-4}}{(L_2 + L_3) \sqrt{L_1 L_4}} \dots (69)$$

¹ In case it is not evident just what the mutual reactance of the two circuits is it may be obtained by calculating the voltage generated in circuit 2 when a current of one ampere is flowing in circuit 1, or vice versa. This voltage is equal to the mutual reactance, in ohms.

Resonance in a Circuit to which Another Circuit is Magnetically Coupled.—In discussing this question we shall calculate the effect of circuit 2 on the resistance and reactance of circuit 1. The method of analysis is somewhat more elementary than that ordinarily given (which depends

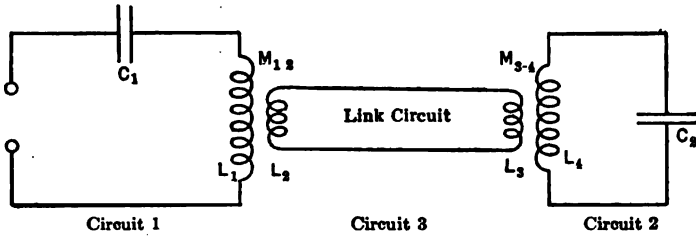

FIG. 82.—“Link-circuit” coupling.

upon the solution of simultaneous differential equations), and perhaps leads to a clearer insight into the mutual reactions of the two circuits. We shall assume unit current flowing in the primary (circuit 1), and get the voltage E_2 induced in the second circuit by this current. This voltage will produce current in the second circuit, which current will be divided into its active and reactive components (in phase with E_2 and 90° out of phase with E_2). The active component will be 90° behind the primary current and will produce a voltage back in the primary circuit which will be 180° out of phase with the primary current; from this voltage we calculate the effect of the second circuit on the resistance of the first.

The resistance of a circuit may be defined as the counter voltage set up in the circuit by a current of one ampere flowing, this counter voltage to be 180° out of phase with the current;

in the same way the reactance of a circuit may be considered as the counter voltage set up in the circuit by a current of one ampere, the counter voltage to be 90° out of phase with the current.

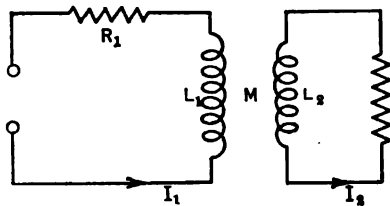

FIG. 83.—Inductively coupled circuits, neither circuit having a condenser.

In Fig. 83 suppose the current I_1 , is one ampere at frequency $\omega/2\pi$. Voltage induced in the secondary

$$E_2 = \omega M I_1 = \omega M \dots \dots \dots (70)$$

Current in circuit 2,

$$I_2 = \frac{E_2}{Z_2} = \frac{\omega M}{Z_2}, \dots \dots \dots (71)$$

and this current lags behind E_2 by an angle θ , defined by the equation $\tan \theta = \omega L_2/R_2$. The active component of I_2 is in phase with E_2 so we put

$$I_2 \cos \theta = \frac{\omega M}{Z_2} \times \frac{R_2}{Z_2}$$

The voltage induced in circuit 1 by this current is

$$I_2 \cos \theta \times \omega M = \frac{\omega M}{Z_2} \frac{R_2}{Z_2} \omega M = \left(\frac{\omega M}{Z_2}\right)^2 R_2. \quad \dots \quad (72)$$

As this voltage lags 90° behind the inducing current $I_2 \cos \theta$ and as $I_2 \cos \theta$ lags 90° behind I_1 this voltage $\left(\frac{\omega M}{Z_2}\right)^2 R_2$ is 180° behind I_1 and so is an *IR* reaction. As we assumed unit current in circuit 1 this voltage $\left(\frac{\omega M}{Z_2}\right)^2 R_2$ is really the increase in resistance of circuit 2, in ohms, due to the current in circuit 2. Hence the apparent resistance of circuit 1 is evidently

$$R'_1 = R_1 + \left(\frac{\omega M}{Z_2}\right)^2 R_2. \quad \dots \quad (73)$$

Now the reactive current in circuit 2 is $I_2 \sin \theta$, and this current lags 90° behind E_2 , which itself lags 90° behind I_1 . The voltage induced in circuit 1 by this current $I_2 \sin \theta$ will be equal to $\omega M I_2 \sin \theta$, and this will lag 90° behind the inducing current $I_2 \sin \theta$, and hence will lag 270° behind I_1 , that is it leads I_1 by 90° .

Now the reactive voltage in circuit 1 due to L_1 is 90° behind the current I_1 . This may seem incorrect at first glance, because it makes the current I_1 lead the reactive voltage by 90° , whereas we know that an inductive circuit draws a lagging current. It must be remembered that the component of the impressed voltage which overcomes the reacting voltage of the circuit must be 180° ahead of the reacting voltage itself; this makes the current in an inductive circuit lag behind the *impressed voltage*, as it should.

It appears then that the voltage induced in circuit 1 by the current $I_2 \sin \theta$ is 180° out of phase with the reactive voltage in circuit 1 due to L_1 of circuit 1, hence the total reactive voltage of circuit 1 will be less when circuit 2 is present than when it is not present.

The amount of voltage induced in circuit 1 by $I_2 \sin \theta$ is $\omega M I_2 \sin \theta$ and this is equal to $\left(\frac{\omega M}{Z_2}\right)^2 \omega L_2$.

So the total reactive voltage in circuit 1 when a current of one ampere is flowing is

$$\omega L_1 - \left(\frac{\omega M}{Z_2}\right)^2 \omega L_2 = \omega \left(L_1 - \left(\frac{\omega M}{Z_2}\right)^2 L_2 \right),$$

and from this we get the equivalent self induction of circuit 1,

$$L'_1 = L_1 - \left(\frac{\omega M}{Z_2}\right)^2 L_2. \dots \dots \dots (74)$$

It is therefore seen that the effect of the current in circuit 2 is to *increase* the resistance of circuit 1 by the amount $\left(\frac{\omega M}{Z_2}\right)^2 R_2$ and to *decrease* its self-induction by an amount $\left(\frac{\omega M}{Z_2}\right)^2 L_2$.

In such a circuit as that shown in Fig. 84 we can at once write the characteristics of circuit 1 by using Eqs. (73) and (74).

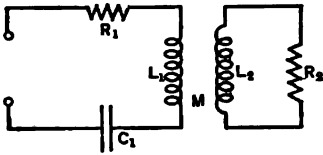

$$R'_1 = R_1 + \left(\frac{\omega M}{Z_2}\right)^2 R_2$$

$$L'_1 = L_1 - \left(\frac{\omega M}{Z_2}\right)^2 L_2$$

Fig. 84.—Inductively coupled circuits with a condenser in the primary.

$$I_1 = \frac{E}{\sqrt{\left[R_1 + \left(\frac{\omega M}{Z_2}\right)^2 R_2\right]^2 + \left[\omega \left(L_1 - \left(\frac{\omega M}{Z_2}\right)^2 L_2\right) - \frac{1}{\omega C_1}\right]^2}} \dots (75)$$

$$I_2 = \frac{E_2}{Z_2} = \frac{\omega M E}{Z_2 \sqrt{\left[R_1 + \left(\frac{\omega M}{Z_2}\right)^2 R_2\right]^2 + \left[\omega \left(L_1 - \left(\frac{\omega M}{Z_2}\right)^2 L_2\right) - \frac{1}{\omega C_1}\right]^2}} \dots (76)$$

These two equations may be written in a somewhat more convenient form by combining terms,

$$I_1 = \frac{E Z_2}{\sqrt{\left[(\omega M)^2 + R_1 R_2 - \omega L_2 \left(\omega L_1 - \frac{1}{\omega C_1}\right)\right]^2 + \left[\omega L_2 R_1 + R_2 \left(\omega L_1 - \frac{1}{\omega C_1}\right)\right]^2}} \dots (77)$$

$$I_2 = \frac{E \omega M}{\sqrt{\left[(\omega M)^2 + R_1 R_2 - \omega L_2 \left(\omega L_1 - \frac{1}{\omega C_1}\right)\right]^2 + \left[\omega L_2 R_1 + R_2 \left(\omega L_2 - \frac{1}{\omega C_1}\right)\right]^2}} \dots (78)$$

In case the impressed frequency is adjusted to give resonance in the primary circuit (without the presence of the secondary) these equations reduce to the forms

$$I_1 = \frac{E Z_2}{\sqrt{(\omega^2 M^2 + R_1 R_2)^2 + \omega^2 L_2^2 R_1^2}} \dots \dots \dots (79)$$

$$I_2 = \frac{E \omega M}{\sqrt{(\omega^2 M^2 + R_1 R_2)^2 + \omega^2 L_2^2 R_1^2}} \dots \dots \dots (80)$$

If M is varied a maximum current will occur in the secondary when

$$\omega^2 M^2 = R_1 \sqrt{R_2^2 + (\omega L_2)^2} = R_1 Z_2. \dots \dots (81)$$

For this value of M the values of the two currents become

$$I_1 = \frac{EZ_2}{R_1 \sqrt{2(Z_2^2 + R_2 Z_2)}} \dots \dots \dots (82)$$

$$I_2 = \frac{E \omega M}{R_1 \sqrt{2(Z_2^2 + R_2 Z_2)}} \dots \dots \dots (83)$$

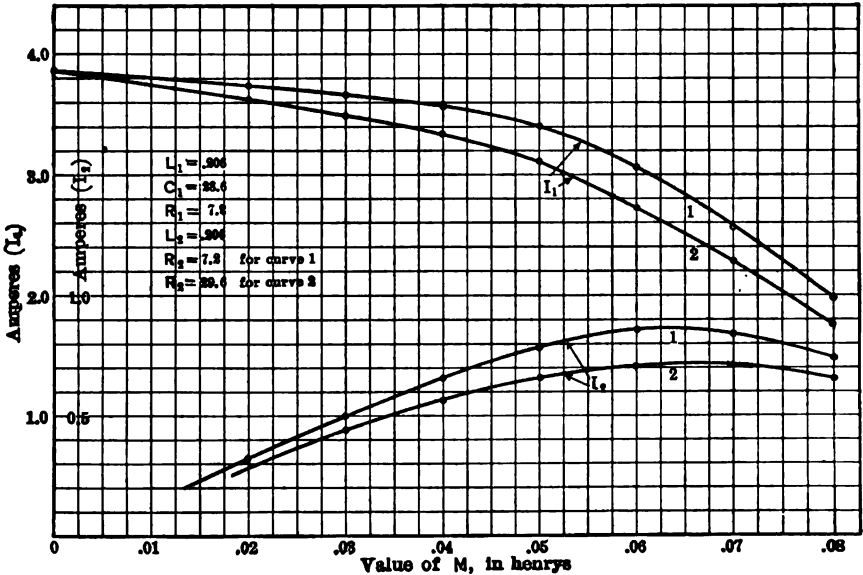

Fig. 85.—Variation of current with M in circuit of Fig. 84, for two values of secondary resistance.

Fig. 85 shows a set of experimental curves to illustrate the relations given above; the circuits were arranged as shown in Fig. 84 and the frequency adjusted for the value which gave resonance in the primary alone; the coupling was then varied and the two currents went through variations as appear from the curves.

With the same value of frequency as used for the curves of Fig. 85 and that coupling which gave maximum secondary current (which value of coupling does not vary greatly as the secondary resistance is varied, so long as the secondary resistance is small compared to the secondary reactance) a series of readings was taken to show the effect of the secondary resistance on secondary current and so on the amount of power transmitted to the secondary circuit. The results are shown in Fig. 86; it

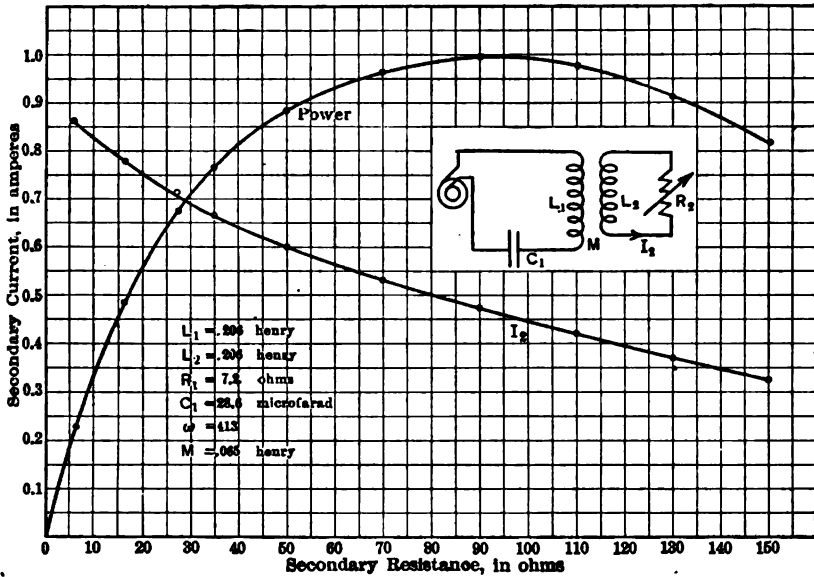

Fig. 86.—Variation of power and current with secondary resistance in circuit of Fig. 84, coupling constant.

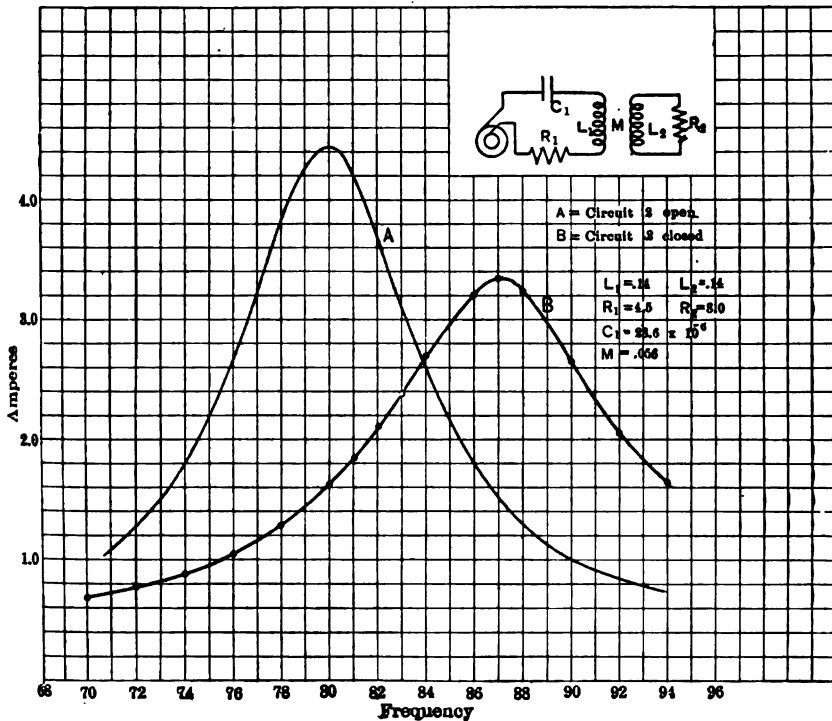

Fig. 87.—Current vs. frequency in circuit of Fig. 84 with secondary open and closed.

is seen that the adjustments for maximum power of this circuit are not very critical.

The resonance curve for such a circuit as that shown in Fig. 84 differs from the curve of the primary alone in that the critical frequency is higher and the resonance curve is not so sharp. The resistance of circuit 1 is increased by the amount given in Eq. (73) and the inductance is decreased by the amount shown in Eq. (74). Fig. 87 shows the resonance curve of a circuit arranged like that of Fig. 84; in dotted lines is shown the resonance curve of the primary without the presence of the secondary. The same

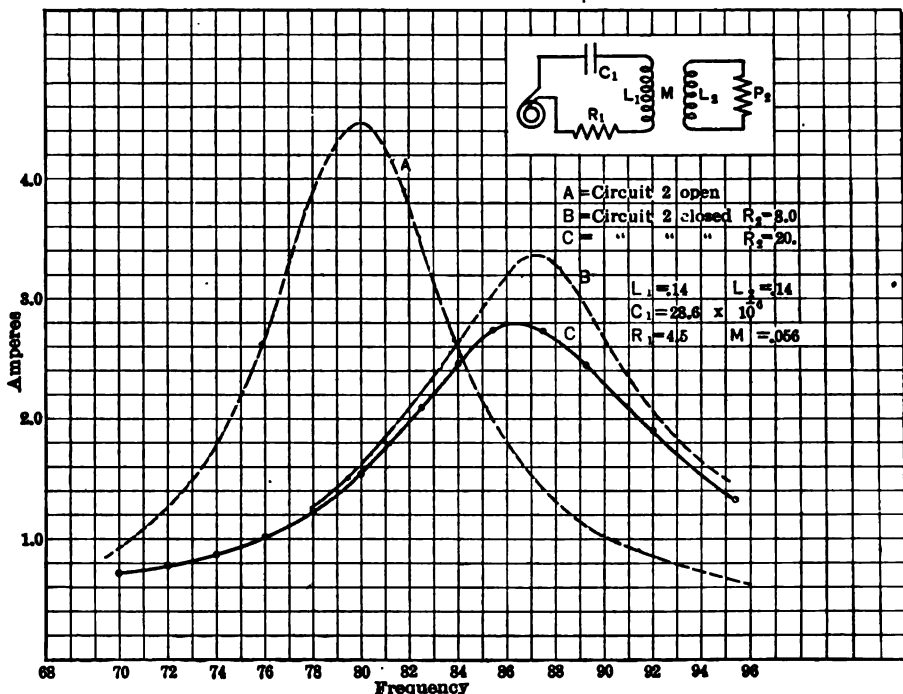

FIG. 88.—Current vs. frequency in circuit of Fig. 84 with added secondary resistance.

voltage was applied to the primary circuit in getting the two sets of curves, hence the magnitudes of current for the two curves give an exact measure of the effect of the secondary circuit upon the first. The calculated R' and L' of the primary, using first the experimental data on the curve sheet of Fig. 87 and then Eqs. (73) and (74) agree within the precision of the experimental work.

The resistance of the secondary circuit was then increased by 12 ohms and another resonance curve taken; the results are shown in Fig. 88; the curves of Fig. 87 are shown in dotted lines for comparison. It is seen that the addition of resistance to the secondary circuit makes the sharp-

ness of resonance less and the effect of the secondary in determining the resonant frequency of the primary is somewhat less than for the lower resistance secondary circuit.

We will next consider the circuit shown in Fig. 89; the condenser is now in the secondary circuit instead of the primary.

In this circuit the resistance of the primary is always increased by the presence of the secondary, but the effect upon the inductance depends upon the frequency impressed on the primary circuit. If the frequency is such as to satisfy the condition for resonance in the secondary ($f = \frac{1}{2\pi\sqrt{L_2C_2}}$), the apparent inductance of circuit 1 will be the same as the actual inductance, that is, the presence of circuit 2 does not affect the inductance of circuit 1. With higher than resonant frequency the apparent inductance of circuit 1 is decreased by circuit 2 and with lower frequency the inductance of circuit 1 is increased. In other words, if I_2 lags behind E_2 , the effect on circuit 1 is to reduce the apparent inductance, whereas if the current in circuit 2

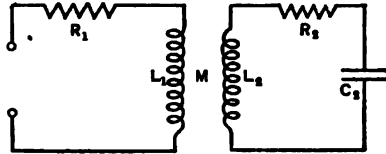

FIG. 89.—Inductively coupled circuit with condenser in secondary.

leads the generated voltage in this circuit, the effect on circuit 1 is to cause an increase in the apparent inductance.

Applying Eqs. (73) and (74) to the circuit of Fig. 89 we get,

$$R'_1 = R_1 + \left(\frac{\omega M}{Z_2}\right)^2 R_2. \quad \dots \dots \dots (84)$$

$$L'_1 = L_1 - \left(\frac{\omega M}{Z_2}\right)^2 \left(L_2 - \frac{1}{\omega^2 C_2}\right), \quad \dots \dots \dots (85)$$

in which

$$Z_2 = \sqrt{R_2^2 + \left(\omega L_2 - \frac{1}{\omega C_2}\right)^2}.$$

It is seen that if $\frac{1}{\omega^2 C_2}$ is greater than L_2 , L'_1 is greater than L_1 ; if

$L_2 = \frac{1}{\omega^2 C_2}$, $L'_1 = L_1$; if L_2 is greater than $\frac{1}{\omega^2 C_2}$ then L'_1 is less than L_1 .

Using the constants given in Eqs. (84) and (85) we can write at once

$$I_1 = \frac{E}{\sqrt{\left[R_1 + \left(\frac{\omega M}{Z_2}\right)^2 R_2\right]^2 + \omega^2 \left[L_1 - \left(\frac{\omega M}{Z_2}\right)^2 \left(L_2 - \frac{1}{\omega^2 C_2}\right)\right]^2}}. \quad (86)$$

$$I_2 = \frac{E \omega M}{Z_2 \sqrt{\left[R_1 + \left(\frac{\omega M}{Z_2}\right)^2 R_2\right]^2 + \omega^2 \left[L_1 - \left(\frac{\omega M}{Z_2}\right)^2 \left(L_2 - \frac{1}{\omega^2 C_2}\right)\right]^2}}. \quad (87)$$

which may be somewhat simplified to the forms

$$I_1 = \frac{EZ_2}{\sqrt{\left[\omega^2(M^2 - L_1L_2) + \frac{L_1}{C_2} + R_1R_2\right]^2 + \omega^2\left[L_1R_2 + L_2R_1 - \frac{R_1}{\omega^2C_2}\right]^2}} \quad (88)$$

$$I_2 = \frac{E\omega M}{\sqrt{\left[\omega^2(M^2 - L_1L_2) + \frac{L_1}{C_2} + R_1R_2\right]^2 + \omega^2\left[L_1R_2 + L_2R_1 - \frac{R_1}{\omega^2C_2}\right]^2}} \quad (89)$$

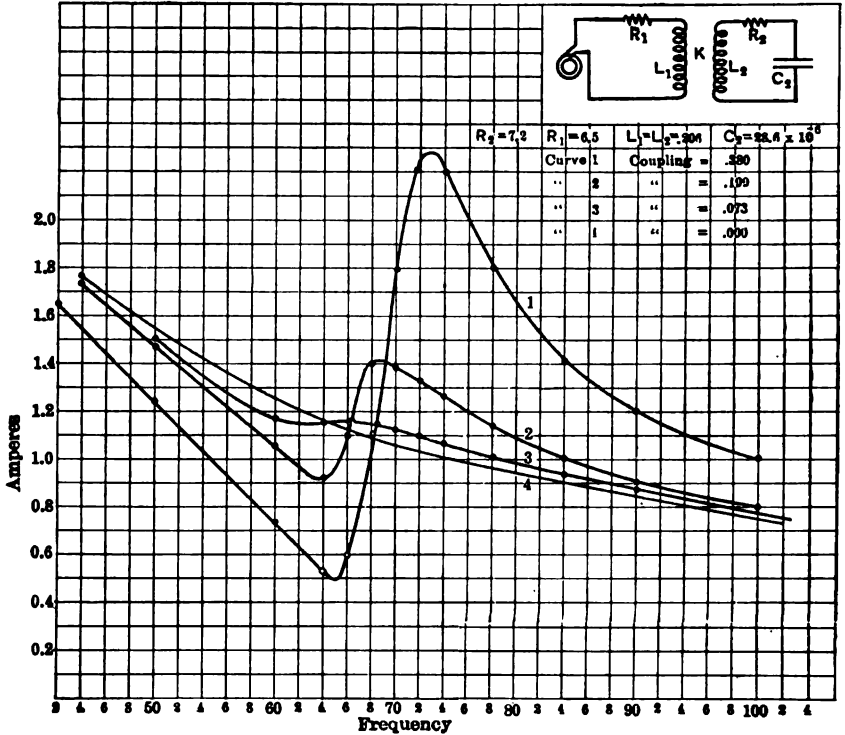
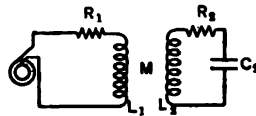

FIG. 90.—Current versus frequency in circuit of Fig. 89.

In Fig. 90 are shown curves of primary current in such a circuit as given in Fig. 89; the voltage impressed on the primary circuit was held constant at 100 volts, and the frequency varied through a suitable range and current readings taken for three values of coupling between the two circuits. The value of primary current was also taken with secondary circuit open, and is shown in dotted line. From these curves it is seen that the effect of the secondary circuit may be either an increase or decrease in the primary current, depending upon the frequency used. In Fig. 91 are shown the values of change in primary resistance and reactance brought

about by the action of the current in circuit 2; they were determined by subtracting from the apparent resistance and reactance of circuit 1 the values of these quantities when the secondary circuit was open.



$$R_2 = 7.2 \quad R_1 = 6.5 \quad L_1 = L_2 = .206 \quad C_2 = 28.6 \times 10^6$$

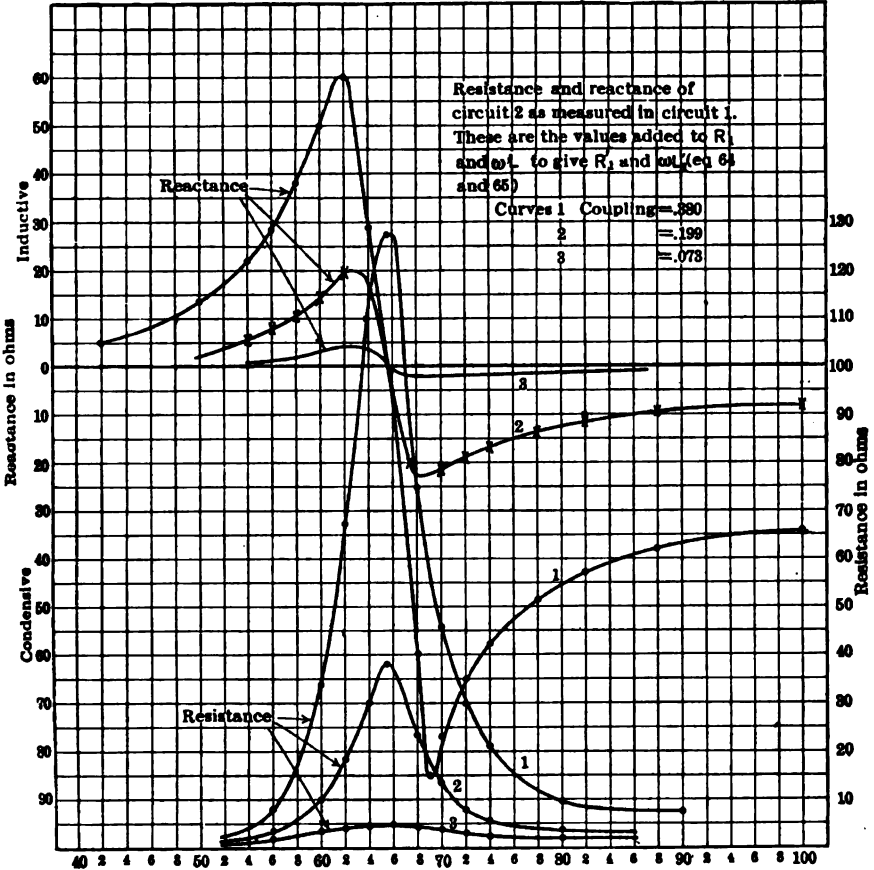

FIG. 91.—Change in primary resistance and reactance due to presence of secondary circuit, for various frequencies.

A closer study of these curves will be worth while when analyzing the action of certain oscillating tube circuits. An oscillating tube may refuse to function if the resistance of the circuit to which it is connected is too high and it will be found that a tube may be made to stop oscillating by tuning to its circuit another circuit coupled to it. The reason is to be

found in the extra value of the resistance added to the oscillating circuit by the second circuit *when this second circuit is brought into resonance with the tube circuit.*

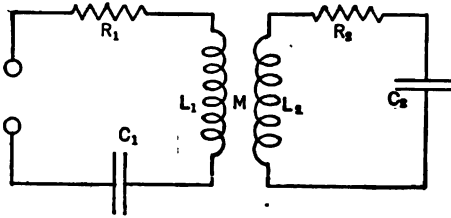

FIG. 92.—General case of inductively coupled circuits.

We next consider the more general case of two coupled circuits, each of which has inductance, capacity, and resistance, as indicated in Fig. 92. The resistance and

inductance of circuit 1 are obtained from Eqs. (73) and (74), as before.

$$R'_1 = R_1 + \left(\frac{\omega M}{Z_2}\right)^2 R_2 \dots \dots \dots (90)$$

$$L'_1 = \left(L_1 - \frac{1}{\omega^2 C_1}\right) - \left(\frac{\omega M}{Z_2}\right)^2 \left(L_2 - \frac{1}{\omega^2 C_2}\right) \dots \dots \dots (91)$$

Then we have,

$$I_1 = \frac{E}{\sqrt{\left[R_1 + \left(\frac{\omega M}{Z_2}\right)^2 R_2\right]^2 + \omega^2 \left[\left(L_1 - \frac{1}{\omega^2 C_1}\right) - \left(\frac{\omega M}{Z_2}\right)^2 \left(L_2 - \frac{1}{\omega^2 C_2}\right)\right]^2}} \dots \dots \dots (92)$$

$$I_2 = \frac{E \omega M}{Z_2 \sqrt{\left[R_1 + \left(\frac{\omega M}{Z_2}\right)^2 R_2\right]^2 + \omega^2 \left[\left(L_1 - \frac{1}{\omega^2 C_1}\right) - \left(\frac{\omega M}{Z_2}\right)^2 \left(L_2 - \frac{1}{\omega^2 C_2}\right)\right]^2}} \dots \dots \dots (93)$$

in which

$$Z_2 = \sqrt{R_2^2 + \left(\omega L_2 - \frac{1}{\omega C_2}\right)^2}$$

In Eq. (92) the resistance term of the impedance is nearly constant as the frequency is varied. The fraction $\omega M/Z_2$ is evidently nearly constant as ω is varied until ω approaches such a value that $(\omega L_2 - 1/\omega C_2)$ is nearly equal to zero. In this region of frequency variation the resistance R'_1 varies greatly as frequency is varied and any solution which we may reach on the basis of R'_1 remaining constant, therefore, will not be accurate for frequencies in the vicinity of the natural frequency of the secondary circuit.

Resonant Frequencies in Coupled Circuits.—On the assumption that R'_1 is constant it is evident that I_1 will be a maximum for any frequency that makes the reactance term of the impedance equal to zero. Hence we write as the condition for resonance

$$L_1 - \frac{1}{\omega^2 C_1} - \left(\frac{\omega M}{Z_2}\right)^2 \left(L_2 - \frac{1}{\omega^2 C_2}\right) = 0 \dots \dots \dots (94)$$

If now we again neglect R_2 in comparison with $\left(\omega L_2 - \frac{1}{\omega C_2}\right)$ thus making it possible to replace Z_2 by $\left(\omega L_2 - \frac{1}{\omega C_2}\right)$, we have

$$L_1 - \frac{1}{\omega^2 C_1} - \frac{M^2}{\left(L_2 - \frac{1}{\omega^2 C_2}\right)^2} \left(L_2 - \frac{1}{\omega^2 C_2}\right) = 0. \quad \dots (95)$$

Now Eq. (95) can be written,

$$L_1 L_2 - \frac{L_1}{\omega^2 C^2} - \frac{L_2}{\omega^2 C_1} + \frac{1}{\omega_4 C_1 C_2} - M^2 = 0,$$

which can be changed, by multiplying through by $\frac{\omega^4}{L_1 L_2}$, to the form

$$\omega^4 - \frac{\omega^2}{L_2 C_2} - \frac{\omega^2}{L_1 C_1} + \frac{1}{L_1 C_1 L_2 C_2} - \frac{\omega^4 M^2}{L_1 L_2} = 0.$$

If we now put

$$\omega_1 = \frac{1}{\sqrt{L_1 C_1}}, \quad \omega_2 = \frac{1}{\sqrt{L_2 C_2}} \quad \text{and} \quad k = \frac{M}{\sqrt{L_1 L_2}},$$

we get

$$\omega^4(1 - k^2) - \omega^2(\omega_1^2 + \omega_2^2) + \omega_1^2 \omega_2^2 = 0. \quad \dots (96)$$

The solution of this equation is obtained by dividing through by $(1 - k^2)$, properly completing the square of the left-hand member and extracting the square root, which gives

$$\omega^2 = \frac{\omega_1^2 + \omega_2^2 \pm \sqrt{(\omega_1^2 + \omega_2^2)^2 - 4(1 - k^2)\omega_1^2 \omega_2^2}}{2(1 - k^2)}$$

By combining terms under the radical this becomes

$$\omega^2 = \frac{\omega_1^2 + \omega_2^2 \pm \sqrt{(\omega_1^2 - \omega_2^2)^2 + 4k^2 \omega_1^2 \omega_2^2}}{2(1 - k^2)}$$

The two solutions for ω , which we call ω' and ω'' , are

$$\omega' = \sqrt{\frac{\omega_1^2 + \omega_2^2 - \sqrt{(\omega_1^2 - \omega_2^2)^2 + 4k^2 \omega_1^2 \omega_2^2}}{2(1 - k^2)}}, \quad \dots (97)$$

and

$$\omega'' = \sqrt{\frac{\omega_1^2 + \omega_2^2 + \sqrt{(\omega_1^2 - \omega_2^2)^2 + 4k^2 \omega_1^2 \omega_2^2}}{2(1 - k^2)}}. \quad \dots (98)$$

When k is large (approximately unity) the values of ω' and ω'' are nearly

$$\omega' = \sqrt{\frac{\omega_1^2 \omega_2^2}{\omega_1^2 + \omega_2^2}}, \quad \dots (99)$$

and

$$\omega'' = \sqrt{\frac{\omega_1^2 + \omega_2^2}{1 - k^2}}. \quad \dots (100)$$

When k is small the values of ω' and ω'' approach the limits

$$\omega' = \frac{\omega_2}{\sqrt{1-k^2}}, \dots \dots \dots (101)$$

and

$$\omega'' = \frac{\omega_1}{\sqrt{1-k^2}}, \dots \dots \dots (102)$$

In Fig. 93 are shown the relations between ω' and ω'' and k ; for small values of k Eqs. (101) and (102) determine the values and for the large values of k Eqs. (99) and (100) are used.

In radio operation it is the practice to tune the primary and secondary circuits, that is, adjustments are made to make ω_1 equal to ω_2 . In this case Eqs. (97) and (98) reduce to the very simple forms

$$\omega' = \frac{\omega}{\sqrt{1+k}}, \dots \dots \dots (103)$$

and

$$\omega'' = \frac{\omega}{\sqrt{1-k}}, \dots \dots \dots (104)$$

in which $\omega = \omega_1 = \omega_2$.

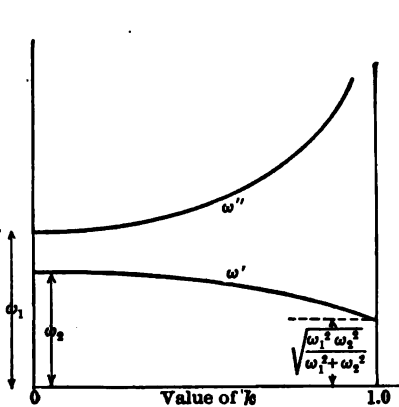

FIG. 93.

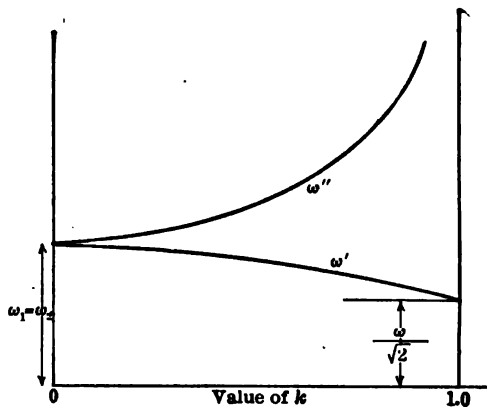

FIG. 94.

FIG. 93.—Variation of ω' and ω'' with k in coupled circuits, primary and secondary not tuned.

FIG. 94.—Variation of ω' and ω'' with k in tuned coupled circuits.

The curves of variation in ω' and ω'' as the coupling is varied for this case of tuned circuits are shown in Fig. 94. It is seen that for weak coupling both ω' and ω'' approach ω , the natural frequency of each circuit; however, it has been pointed out that the neglect of R_2 in obtaining the solutions of the resonant frequencies that the values of ω' and ω'' do not hold good when they have values in the vicinity of the natural frequency of

the secondary circuit. Hence we can now see that for weak couplings the solutions for ω' and ω'' do not hold good.

Referring to Eq. (93) it is seen that $I_2 = I_1 \frac{\omega M}{Z_2}$, and hence in so far as the factor $\frac{\omega M}{Z_2}$ is independent of the frequency changes, I_2 will have maximum values at the same frequencies as give maxima for I_1 . However, the factor $\frac{\omega M}{Z_2}$ is not independent of the frequency, and this is especially so in the region of frequency fixed by the relation $(\omega L_2 - \frac{1}{\omega C_2}) = 0$; for fre-

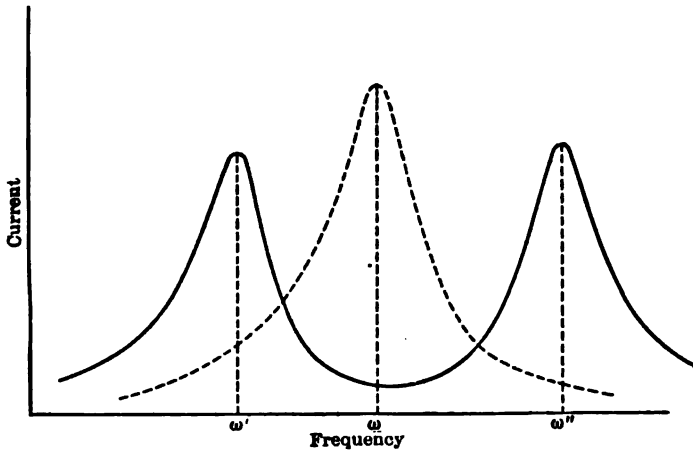

FIG. 95.—Resonance curves for circuit of Fig. 92.

quencies less than this the value of $\frac{\omega M}{Z_2}$ increases with the frequency and for values of frequency higher, the value of $\frac{\omega M}{Z_2}$ decreases with an increase of frequency.

We can then conclude that, for frequencies in the region of

$$\omega_2 = \frac{1}{\sqrt{L_2 C_2}}$$

Eqs. (103) and (104), while incorrect for primary current maxima, are still more incorrect for the maxima of secondary current. In consequence of the changes in the value of $\frac{\omega M}{Z_2}$ noted above, we may predict that when ω' and ω'' are not in the region of ω_2 the calculated values of ω' and ω'' will be more accurate for the primary than for the secondary circuit, and that the actual value of ω' of the secondary circuit will be somewhat

higher than that for the primary and that the actual value of ω'' for the secondary will be somewhat lower than ω'' for the primary current.

The general form of the resonance curve of the circuit shown in Fig. 92 is indicated in Fig. 95; the dotted curve shows the resonance for one circuit by itself.

The value of the coefficient of coupling can be calculated from the spacing of the resonance peaks of the current curves; thus from Eqs. (103) and (104) we get the relation

$$\frac{\omega'^2}{\omega''^2} = \frac{1-k}{1+k'}$$

from which there is obtained

$$k = \frac{\omega''^2 - \omega'^2}{\omega''^2 + \omega'^2} \dots \dots \dots (105)$$

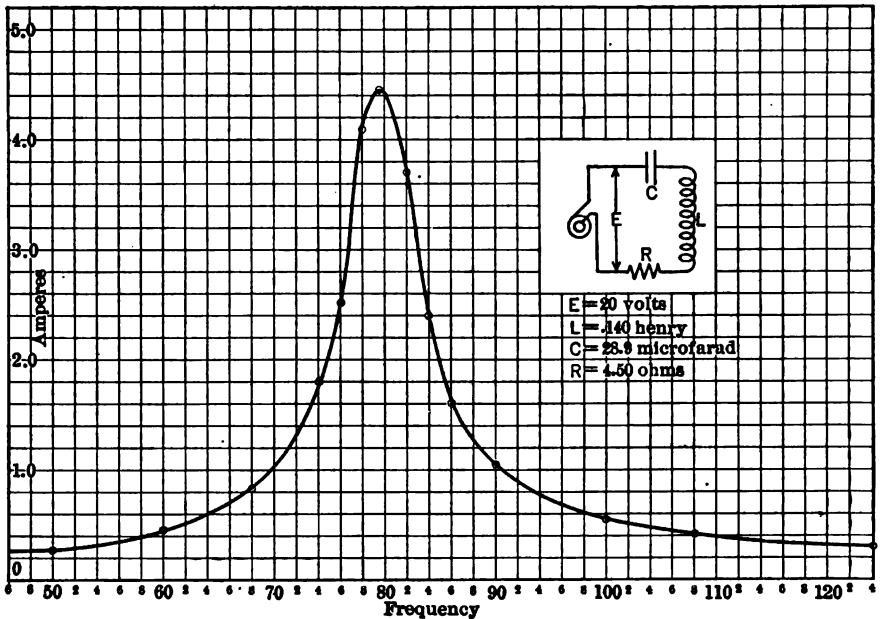

Fig. 96.—Experimental resonance curve for single circuit.

In case the resonance frequency of one circuit by itself is known, and assuming tuned circuits, the equation for coupling value becomes more simple in form, giving the closely approximate value

$$k = \frac{\omega'' - \omega'}{\omega}, \dots \dots \dots (106)$$

ω being the frequency of one circuit by itself.

In the foregoing discussion of resonant frequencies formulæ have been derived using ω for frequency; it is of course to be remembered that ω is

not frequency, but 2π times the frequency. The value of ω has been used rather than frequency itself to save the repeated writing of the quantity 2π throughout all the derivations.

In Figs. 96 to 103 are shown some experimental curves of resonance in coupled circuits for different conditions as regards coupling, resistances, tuning, etc.; Fig. 96 shows the resonance curve for a single circuit having $L=0.140$ henry, $C=28.9$ microfarads, and $R=4.50$ ohms.

Fig. 97 shows the resonance curves for two coupled circuits, each circuit had the same constants as those given for Fig. 96; the coefficient of coupling was 0.36. The curve of primary current is shown by the full line and that for the secondary circuit by the dotted line. The two reso-

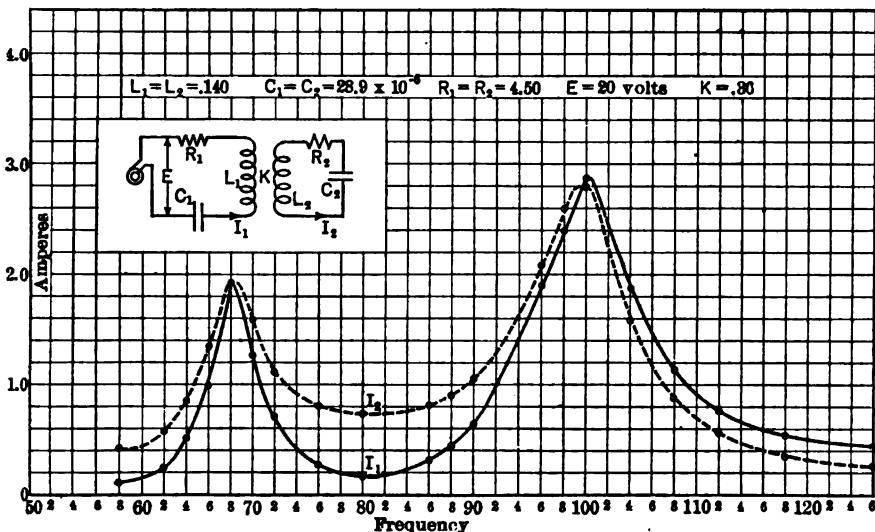

Fig. 97.—Resonance curve for coupled circuits; each circuit having constants as in Fig. 96.

nant frequencies check with those calculated from Eqs. (103) and (104) within the precision of the test.

In Figs. 98 and 99 are shown curves of current for the same two circuits as those used in Fig. 97 but with different values of coupling, this being 0.18 for Fig. 98 and 0.07 for Fig. 99. It may be seen that with small values of coupling the two frequencies merge into one another and Eqs. (103) and (104) do not predict accurately the resonant frequencies of the primary circuit and for reasons noted in the derivation of the formulæ; the predicted values of ω' and ω'' for the secondary circuit differ from the actual values more than do those of the primary circuit.

A peculiarity of all these resonance curves is seen in the relative values of the primary and secondary currents; between the two resonant fre-

quencies the secondary circuit carries a greater current than the primary but for all other frequencies the primary carries a greater current. If a weaker coupling than that used in the adjustments for Fig. 99 had been

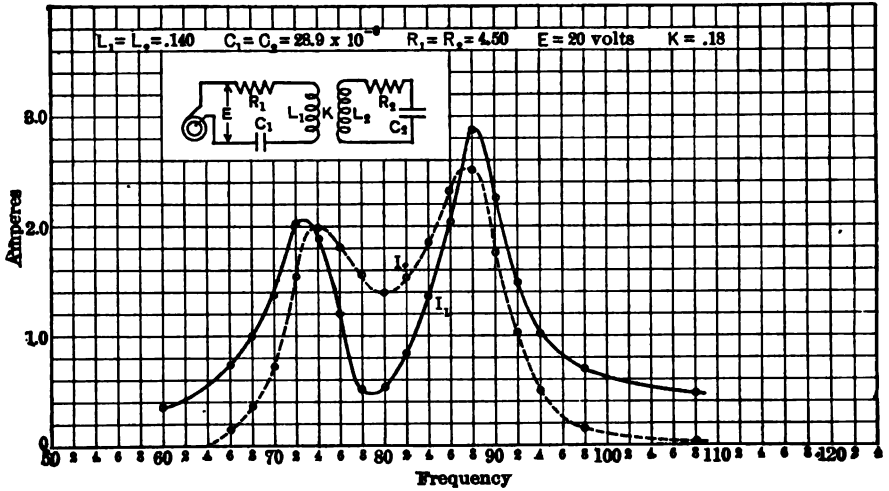

Fig. 98.—Resonance curves for circuit as shown in Fig. 97, $k = 0.18$.

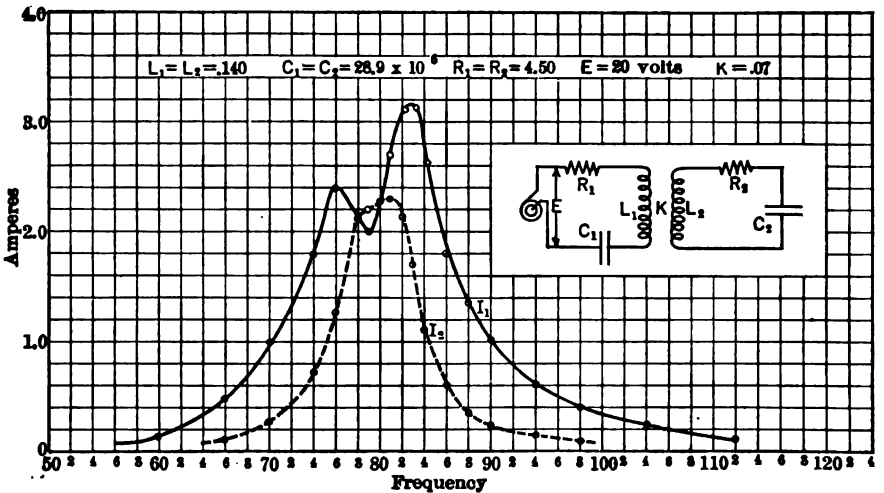

Fig. 99.—Resonance curves for circuit as shown in Fig. 97, $k = 0.07$.

used it would have been found that the primary current was greater than the secondary current for all values of frequency.

In Fig. 100 is shown the result of increasing the resistance of the secondary circuit from 4.5 to 9.7 ohms; with this exception the circuits

were exactly the same as those used for Fig. 97. By comparison of the two sets of curves it will be seen that the two resonant frequencies are, within the precision of measurements, the same for the two conditions; the value of the current at resonance is, however, decreased in nearly the proportion predicted from the value of resistance, calculated from Eq. (90). The decrease in current, it will be noted, takes place in both circuits although the resistance of the secondary circuit only was increased. The resonance is much less marked than for the lower resistance used in Fig. 97.

Form of Resonance Curve.—The form of the resonance peaks is determined by the combined decrements of both circuits. For the simplest

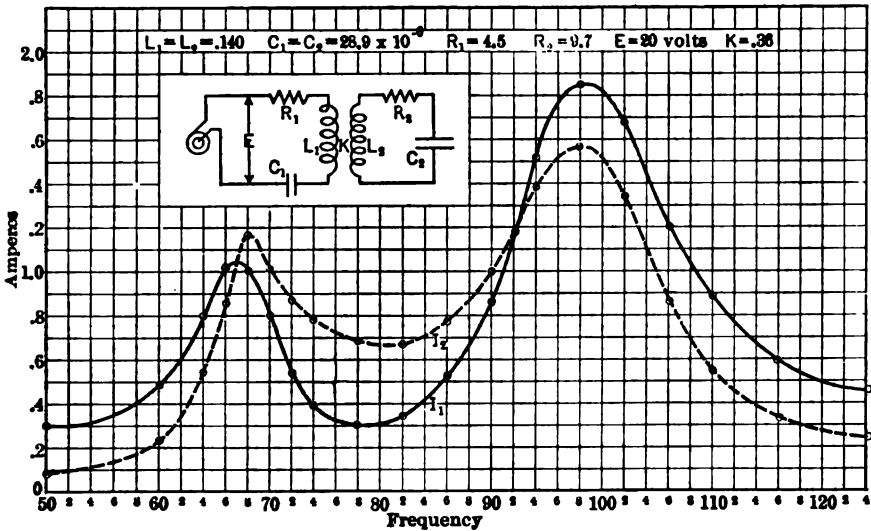

Fig. 100.—Resonance curves for circuit shown in Fig. 97 with added secondary resistance.

case, that of tuned circuits, it will be found that the decrements will be nearly given by the approximate formulæ:

For the frequency ω'

$$\delta' = \frac{\delta_1 + \delta_2}{2\sqrt{1+k}}, \dots \dots \dots (107)$$

and for the frequency ω''

$$\delta'' = \frac{\delta_1 + \delta_2}{2\sqrt{1-k}}, \dots \dots \dots (108)$$

in which δ_1 and δ_2 are the decrements of circuits 1 and 2 when not affected by other circuits.

The decrements δ' and δ'' , calculated from the shape of the curves of Figs. 97 and 98 by use of Eq. (47) check with the values given by Eqs.

(107) and (108) fairly well; it is noticeable that in all the curves given the width of the resonance curve is greater for the higher frequency than

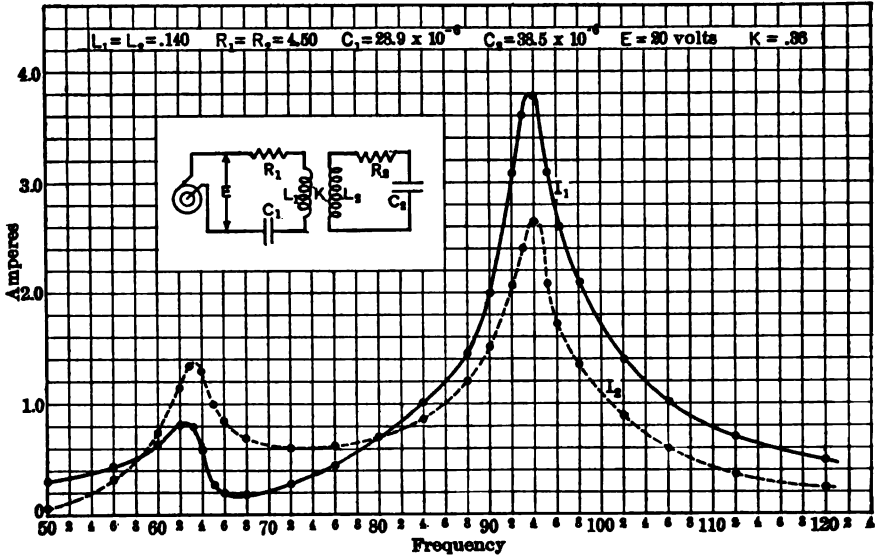

Fig. 101.—Resonance curves for coupled untuned circuits.

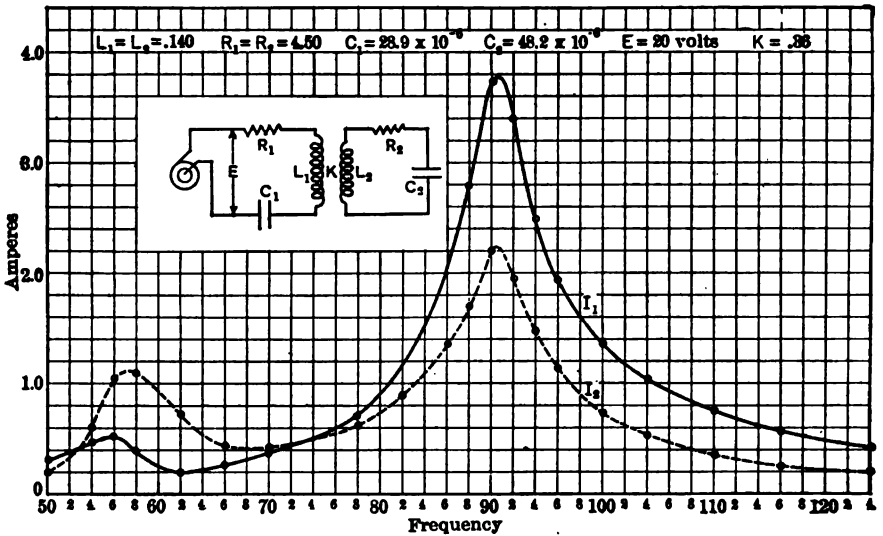

Fig. 102.—Resonance curves for coupled untuned circuits.

for the lower, indicating thereby a greater decrement. With weak coupling the form of the curves does not permit the calculation of δ' and δ'' , because the two peaks merge into one.

Circuits not Tuned.—In Figs. 101 and 102 are shown the resonance curves for two circuits which are not tuned, that is, ω_1 is not equal to ω_2 . For this condition the curves are not as symmetrical as for the tuned condition, and the currents in the two circuits are no longer nearly equal to each other at the two resonant frequencies. At one resonant frequency the primary circuit carries more current than the secondary and at the other frequency the reverse is true. The difference in the two currents is greater the greater the difference in the

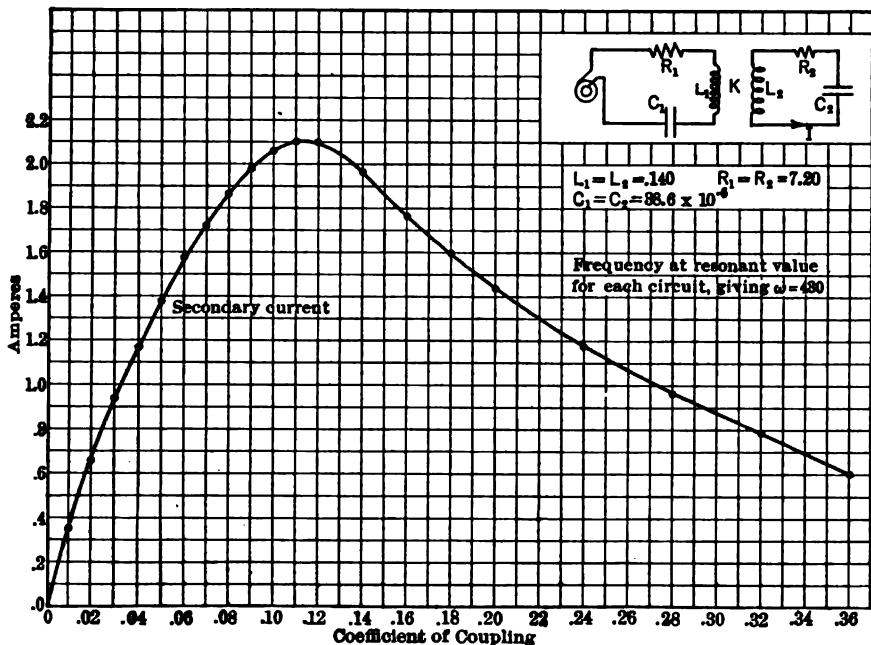

Fig. 103.—Secondary current vs. coefficient of coupling in tuned coupled circuits.

natural periods of the two circuits. For Fig. 101 the natural frequency of circuit 2 is 15 per cent lower than that of circuit 1, and for Fig. 102 circuit 2 has a natural frequency 29 per cent lower than that of circuit 1.

Variation of Coupling with Tuned Circuits.—In Fig. 103 is shown the effect of varying the coupling between circuits 1 and 2, they being tuned alike. A constant e.m.f. was impressed on circuit 1 and the coupling of the two circuits was gradually increased from zero to the maximum obtainable. It might seem at first sight that the secondary current would be greater the greater the coupling, as would occur in ordinary transformer tests, but with tuned circuits as used in radio this is not the case. For a given resistance of circuits there will be

a certain coupling which gives the greatest secondary current and the lower the resistance of the circuits the less this critical value of coupling will be.

This might be predicted from Eq. (33) by differentiating I_2 with respect to M ; it will be found that with tuned circuits having impressed on the primary a voltage of the same frequency as that for which the circuits are tuned, a certain value of M will produce a maximum secondary current and this value of M will depend upon the resistances in the two circuits. This condition for maximum secondary current proves to be fixed by the relation,

$$\omega^2 M^2 = R_1 R_2. \dots \dots \dots (109)$$

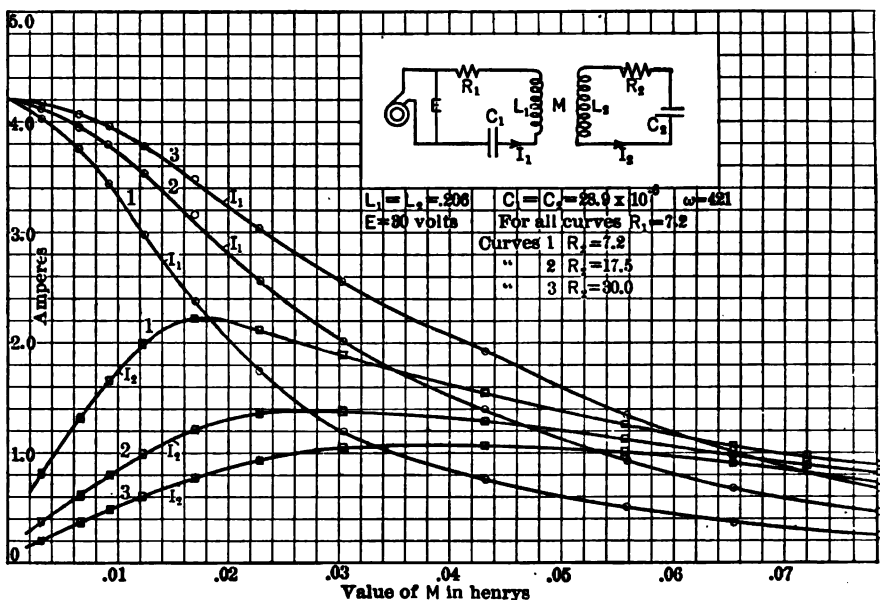

FIG. 104.—Current vs. mutual inductance in tuned coupled circuits, with different values of secondary resistance.

The curves of Fig. 104 were taken with the idea of proving this relation and also to show the effect of the secondary resistance on the sensitiveness of the adjustment for maximum secondary current. If the two circuits are tuned alike and the frequency of the e.m.f. impressed on the primary is the same as the natural frequency of either circuit the values of the primary and secondary current may be obtained by simplifying Eqs. (92) and (93) and are found to be

$$I_1 = \frac{ER_2}{R_1 R_2 + \omega^2 M^2} \dots \dots \dots (110)$$

and

$$I_2 = \frac{E\omega M}{R_1 R_2 + \omega^2 M^2} \dots \dots \dots (111)$$

The experimental curves given in Fig. 104 follow the values predicted from Eqs. (110) and (111) within the precision of measurement, that is, within less than 1 per cent.

Resonance in Circuits with Capacitive Coupling.—The equations for I_1 and I_2 are obtained for this case in a fashion exactly the same as that used for the magnetic coupling, and the conclusions reached are nearly the same. Using ω_1 , ω_2 and k in the same sense as for the magnetically coupled circuits we get for the two resonant frequencies of the combination

$$\omega' = \sqrt{\frac{\omega_1^2 + \omega_2^2 + \sqrt{(\omega_1^2 - \omega_2^2)^2 + 4k^2\omega_1^2\omega_2^2}}{2}} \dots \dots (112)$$

$$\omega'' = \sqrt{\frac{\omega_1^2 + \omega_2^2 - \sqrt{(\omega_1^2 - \omega_2^2)^2 + 4k^2\omega_1^2\omega_2^2}}{2}} \dots \dots (113)$$

In applying these formulæ the values of ω_1 and ω_2 must be calculated in a somewhat different manner than was used for the magnetically coupled circuits. It will be remembered that for magnetic coupling these two frequencies were fixed by the L and C of the circuit in question and were independent of the constants of the other circuit and of the coupling used.

Such is not the case for capacitive coupling, however. The frequencies ω_1 and ω_2 depend upon the capacity used in the other circuit and upon the coupling in the following manner.

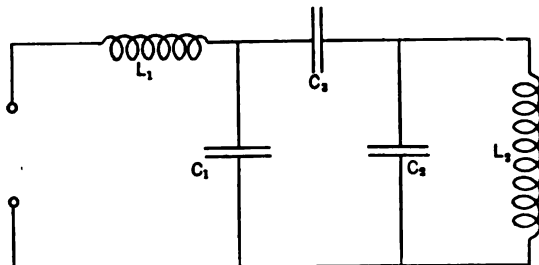

FIG. 105.—Capacitively coupled circuits.

In Fig. 105 the frequency ω_1 is fixed by L_1 and by the capacity C_1 in parallel with C_3 and C_2 in series. Thus ω_1 may be varied by changing either the coupling condenser C_3 , or the capacity of the second circuit C_2 . Hence we have the formulæ

$$\omega_1 = \frac{1}{\sqrt{L_1 \left(C_1 + \frac{1}{\frac{1}{C_2} + \frac{1}{C_3}} \right)}} = \frac{1}{\sqrt{L_1 \left(C_1 + \frac{C_2 C_3}{C_2 + C_3} \right)}} \dots \dots (114)$$

and

$$\omega_2 = \frac{1}{\sqrt{L_2 \left(C_2 + \frac{C_1 C_3}{C_1 + C_3} \right)}} \dots \dots \dots (115)$$

For the value k , we have

$$k = \frac{C_3}{\sqrt{(C_1 + C_3)(C_2 + C_3)}} \dots \dots \dots (116)$$

In Fig. 106 are shown the resonance curves for a combination of circuits nearly like that shown in Fig. 105, the coupling condenser was in two parts as shown in the sketch on the curve sheet.

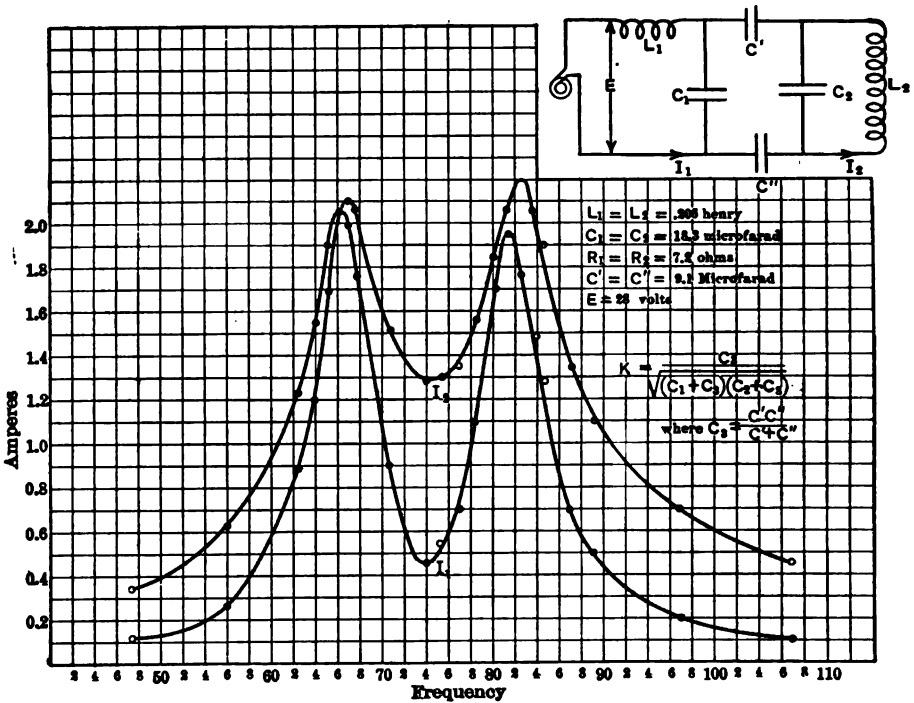

FIG. 106.—Resonance curves for capacitively coupled circuits.

Using the values of L and C indicated on the curve sheet we have

$$\omega_1 = \frac{10^3}{\sqrt{.206 \left(18.3 + \frac{4.55 \times 18.3}{4.55 + 18.3} \right)}} = 470$$

or $f_1 = 74.8$ cycles and the same value for f_2 .

From the curve sheet $f'' = 82.5$ and $f' = 67.0$, so we find k from the curve sheet to be 0.208, by Eq. (106). By using the known values of L and C_1 , C_2 , and C_3 , and Eq. (116), we find k to be 0.207.

The value of k could have been calculated without knowing the constants of the circuits, by using Eq. (105).

We have

$$k = \frac{82.5^2 - 67.0^2}{82.5^2 + 67.0^2} = .207.$$

When $L_1C_1 = L_2C_2$, Eqs. (114) and (115) reduce to the simple forms

$$\omega' = \omega\sqrt{1+k}, \quad \dots \dots \dots (117)$$

$$\omega'' = \omega\sqrt{1-k}, \quad \dots \dots \dots (118)$$

and if further $C_1 = C_2$ then when C_3 is varied, thus varying the coupling, ω' stays constant and equal to $\frac{1}{\sqrt{L_1C_1}}$.

Characteristics of Circuits having Distributed Inductance and Capacity.—The analyses of circuits given so far apply to those in which the inductance and capacity are concentrated; another way of specifying the circuits with which we have been dealing is to state that the current, at any given instant, is exactly the same at every point in the circuit. This condition holds for the majority of radio circuits, but there are cases where it evidently does not obtain, thus every antenna has zero current at its farther end, whereas the current entering it at the base may be many amperes. This is the most striking case of a circuit which has a current varying along its length, but there are others in which the same effect exists to a lesser degree. A coil, for example, may have an internal distributed capacity which appreciably affects its behavior.

The change in current at successive points along an antenna is due entirely to the distributed capacity; each unit length contributes its share to the total capacity and of course requires its proportion of the total charging current. The current flowing in at the base of the antenna must be sufficient to charge the whole length, while that flowing past the middle point of the antenna must be sufficient to charge merely the upper half of the antenna, and so will be considerably less than the current at the base of the antenna.

Every coil has more or less distributed capacity, every piece of the winding acting as one plate of a condenser for every other part because the various parts are at different potentials and so will have electric fields set up between them when the coil is excited. But, if when a coil is used, it sets up an electric field as well as a magnetic field, it must be considered

as a combination of coil and condenser. This internal capacity varies in magnitude appreciably as the frequency, at which the coil is used, is varied and so cannot be treated correctly as a concentrated capacity. As ordinarily used a coil does not show much effect from this internal capacity because the condenser to which the coil is attached has so much more capacity that the internal capacity is completely masked; if, however, the coil is used for tuning a circuit and the tuning condenser used has a small capacity then the internal capacity may produce an appreciable effect on the tuning qualities of the circuit. The calculation of this internal capacity and its effect on the apparent inductance of a coil will be taken up in the next chapter.

Now the resistance and reactance of such a circuit (having distributed capacity and inductance) vary with the frequency through a very large range of values; the resistance (as measured at the base of the antenna)

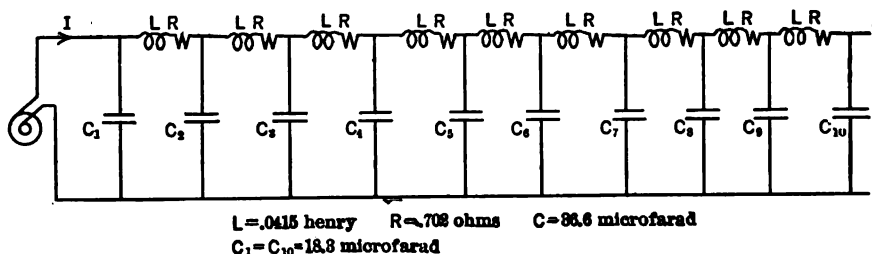

FIG. 107.—A circuit having distributed inductance and capacity, similar to an antenna.

goes from very small to very large values, while the reactance changes from a large inductive reactance to an equally large capacitive reactance. Moreover, these changes occur periodically as the impressed frequency is continually changed.

To demonstrate experimentally the peculiar characteristics of a circuit having distributed constants, the author built an artificial line having inductance, capacity, and resistance, as shown in Fig. 107; this line resembles somewhat a long antenna, having inductances and capacities, however, several times as large as those of an actual antenna.¹

A variable frequency was impressed on this artificial line and, by means of a wattmeter, ammeter, and voltmeter its resonance characteristics were determined. The impressed voltage was kept constant at 20 volts and the frequency varied in small steps, from 12 to 152 cycles per second. Fig. 108 shows the current which flowed from the generator into the line at the various frequencies, the line being open at its distant end. The line showed six frequencies in the range used, at which we can say the line

¹ See "Some Experiments with Long Electrical Conductors," by John H. Morecroft, Proc. I.R.E., Vol. 5, No. 6, Dec., 1917.

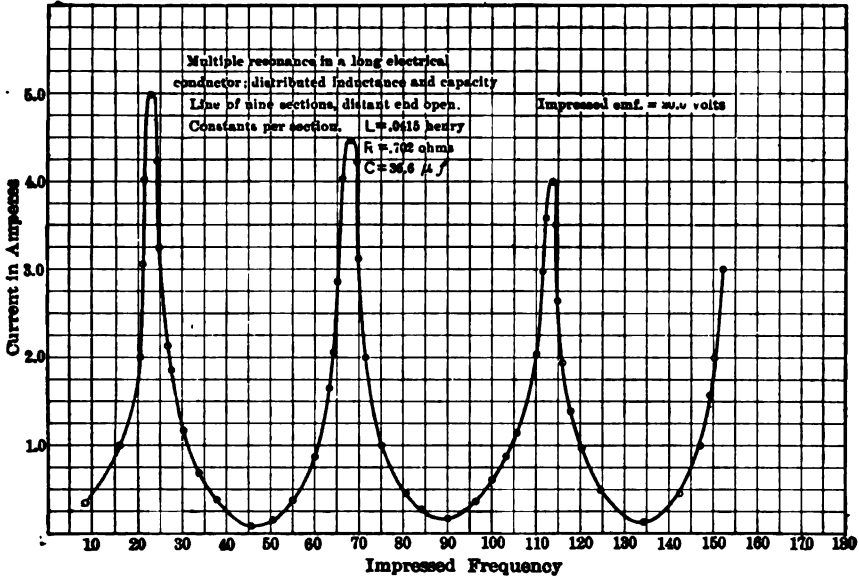

FIG. 108.—Current vs. frequency for circuit shown in Fig. 107.

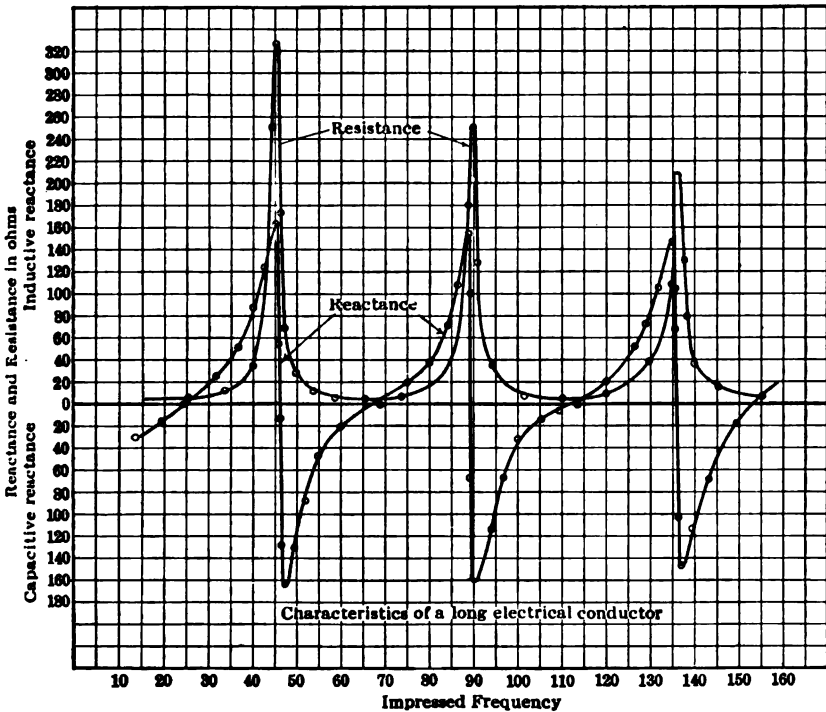

FIG. 109.—Resistance and reactance vs. frequency for circuit shown in Fig. 107.

was in resonance, meaning by the term resonance a frequency at which the power factor was unity, the line offering resistance reaction only. Three of the frequencies correspond to what we have called parallel resonance, the current being a minimum and the other three to series resonance giving large values of current.

The resistance and reactance of the line were calculated from the meter readings and are shown in Fig. 109. The resistance varies periodically from a low value, corresponding to series resonance, to a high value, corresponding to parallel resonance.

The reactance of the line varies periodically from inductive to capacitive reactance and takes all values between 165 ohms positive and 165 ohms negative. From the results shown in Fig. 109 it may be judged how indefinite are the so-called constants of such a circuit.

CHAPTER II

RESISTANCE—INDUCTANCE—CAPACITY

General Concept of Resistance.—The elementary idea of resistance, obtained by a student analyzing continuous current circuits, must be very greatly enlarged and generalized when studying high frequency circuits. In the continuous-current circuit, Ohm's law is in general a sufficient definition for the term resistance, that is, $R = E/I$. This definition presupposes that all of the voltage E is used up in overcoming the resistance reaction of the circuit; there must be no reaction such as the c.e.m.f. of a motor, or c.e.m.f. such as exists in a circuit in which storage batteries are being charged, or else the definition is ordinarily changed to the form

$$R = \frac{E_{imp} - E_c}{I},$$

where

E_{imp} = the impressed voltage;

E_c = the counter voltage of motor, batteries, etc.

This restated definition must be still more generalized when the ordinary alternating current circuit is considered, in fact, a new concept of resistance must be obtained. It might seem that Joule's law would serve sufficiently to define resistance; this law states that the electrical power liberated as heat in a circuit is given by the equation

$$\text{Heat generated} = I^2 R t.$$

Certainly this law is a more general definition of resistance than Ohm's law because it automatically excludes the effects of counter e.m.f.'s., etc.; thus a storage battery, being charged, might (if suitable precautions were taken) be immersed in a calorimeter while being charged and the heat produced be measured by the rise in temperature of the calorimeter water. This amount of heat, properly substituted in Joule's law, will determine the resistance of the circuit in so far as this resistance manifests itself in producing heat.

However, electric energy may be dissipated in forms other than heat; thus radiation of electro-magnetic waves from an antenna dissipates energy from the circuit as truly as does the ordinary heating of the circuit.

These elementary considerations force us to adopt a new concept of resistance, it being based on the idea that any transfer of energy from (or to) that part of the circuit, the resistance of which is desired, must be considered in determining the resistance. Thus the resistance between two points in a circuit a - b , Fig. 1, is defined by the equation,

$$R = \frac{\text{power transferred between points } a \text{ and } b}{I^2} \dots (1)$$

This "power transferred" between a and b may be *leaving* the electrical circuit between these two points or it may be *entering* the circuit between these points. If power is leaving the circuit between these points, as heat or otherwise, the resistance is *positive*; if power is entering the circuit between these two points the resistance is *negative*, and if power is entering the circuit at the same rate as it is leaving then the resistance is zero.

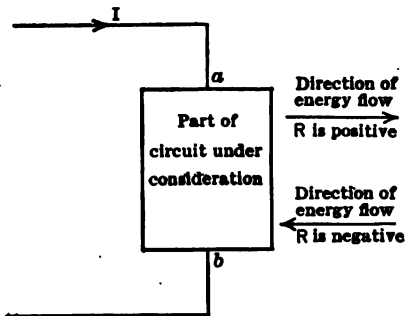

Fig. 1.—If power is leaving the circuit the resistance is positive so that if power is entering the circuit its resistance must be considered negative.

From this standpoint any electrical circuit carrying current, after reaching the steady state (no change in the amplitude of the current) has on the whole, zero resistance. Of course we know that the circuit does actually have resistance, but we may consider the source of power supply as having as much negative resistance as the rest of the circuit has positive resistance. At the generator (or other source of power supply) energy is entering the circuit as fast as it is dissipated in other parts of the circuit. If the circuit, as a whole, has positive

resistance the current must be decreasing in amplitude; this state of affairs occurs in the ordinary damped oscillatory discharge of a condenser, whereas a circuit which takes an appreciable time to build up to its steady state has, during the time required to reach the steady state, on the whole a negative resistance because, considering the circuit as a whole, energy is entering at a rate faster than that at which energy is leaving.

Various Factors Affecting the Resistance of a Circuit.—Among the factors contributing to the resistance of a radio circuit are to be considered (1) resistance of the conductor itself; (2) resistance of neighboring closed circuits and their proximity; (3) magnetic material close enough to the circuit to be magnetized by it; (4) losses in the dielectric of any condenser in the circuit; (5) corona losses from parts of the circuit; (6)

radiation of electric-magnetic energy. All of these factors vary with the frequency of the current in the circuit, some of them with the magnetic gradient set up by the circuit and some with the electric gradient set up by the circuit. Each will be taken up in turn and analyzed as much as seems suitable for a text of this kind.

Conductor Resistance.—The resistance of a conductor, in the form of a wire, to the flow of continuous current is given by the formula

$$R = \frac{\rho l}{a} \dots \dots \dots (2)$$

in which ρ is the specific resistance of the material composing the conductor.

l is the length of the conductor;

a is the cross-sectional area of the conductor.

This formula assumes that all parts of the cross-section of the conductor carry the same proportion of the total current; in other words that the current density is uniform throughout the section of the conductor. This assumption is true for continuous current or for alternating current of very low frequency. If the conductor is large in cross-section or the frequency is high, the inner sections of the conductor carry a relatively small part of the total current, the density of current being greatest at the surface of the conductor; in fact for very high frequencies a comparatively thin skin on the surface of the conductor carries practically all the current, so much so that if the center part of the conductor were removed, leaving nothing but a thin walled tube of the same diameter as the original wire, the resistance would be practically the same. This tendency of the current to concentrate on the outer surface of the wire at high frequencies is called the *skin effect*, the reason for the name being obvious. If there are no other conductors carrying current in the vicinity of the one in question this distribution of current will be symmetrical about the axis of the wire, but if there are other current-carrying conductors in the neighborhood the distribution of current through the cross-section of the wire may be irregular, perhaps only the surface part of the conductor on one side carrying an appreciable current.

Any distribution of current other than the regular distribution of equal current density throughout the section of the conductor will result in an increase in the resistance of the conductor; this increase may be so great that the resistance for a high frequency alternating current may be many times as much as the resistance of the same wire for continuous current.

A simple illustration of this effect is given in Fig. 2, showing three 10-ohm resistances in parallel. Suppose the resistance of this combination is determined by the power loss instead of by the ordinary law for

resistances in parallel. Let 3 amperes flow through each resistance, giving a line current of 9 amperes and a power loss of $3 \times (3^2 \times 10) = 270$ watts. Then the total resistance will be obtained by the equation $R = P/I^2$ or $270/9 = 3.33$ ohms, the same as we should get by the law for resistances in parallel.

Now suppose that for some reason or other the current redistributes itself so that the two outside paths carry 4 amperes each and the center

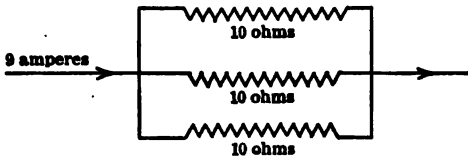

FIG. 2.—A solid conductor of 3.33 ohms resistance may be considered as three separate filaments each of 10 ohms resistance.

one carries 1 ampere. (Such a redistribution might well occur if the combination were used in a high frequency circuit.) The line current will again be 9 amperes and the loss will be $(2 \times (4^2 \times 10)) + (1 \times (1^2 \times 10)) = 330$ watts, which, divided by the square of the line current, gives a resistance of 4.08 ohms, a considerable increase over the value for a uniform distribution of current between the different paths.

The paths shown in Fig. 2 might represent three of the imaginary filaments into which a wire may be supposed divided, and the calculation shows that any distribution of current between the filaments other than uniform distribution results in an increase in the resistance of the conductor; moreover, the greater the non-uniformity of current density the greater will be the corresponding increase in resistance.

Skin Effect in Straight Wires.—The non-uniformity of current distribution referred to above occurs in every conductor carrying alternating current, the current density being greater at the surface than at the center of the wire, but this non-uniformity is not appreciable unless the wire is large in diameter, or the frequency is high; the increase in resistance due to skin effect depends upon the product of the cross-section and the frequency and for copper wires the general idea given by the following table is useful.

Frequency multiplied by the Cross-section in circular mils.	Ratio of a.c. to c.c. resistance.
10,000,000	1.003
20,000,000	1.012
100,000,000	1.30

As an example No. 10 wire has a cross-section of 10,000 circular mils; at a frequency of 2000 cycles its a.c. resistance is 1.2 per cent greater than its c.c. resistance, while at 10,000 cycles its resistance would have increased over its c.c. value by 30 per cent.

An exact analysis shows that the ratio of a.c. resistance to c.c. resistance may be expressed in terms of diameter, permeability, frequency, and resistivity; a correct expression involves an infinite series of terms, but these series have been summed so that accurate data are available for calculating the resistance of any round wire, the permeability and resistivity of which are known. For copper wire, in which the permeability is unity, tables have been compiled which present the data in convenient form. In the curves of Figs. 3 and 4 is shown the factor, m , by which the c.c. resistance must be multiplied to give the resistance for alternating current. Plotted as abscissæ are values of $r\sqrt{f}$, where r is the radius of the wire in cm. and f is the frequency of the current being used.

It is sometimes useful to know how a large wire can be used without having its a.c. resistance exceed its c.c. resistance by more than a specified amount. The data given in the accompanying table, compiled by L. W. Austen, may be useful for this purpose:

TABLE I
WIRE DIAMETERS

Largest wire (straight) which can be used without the high frequency resistance exceeding the c.c. resistance by more than 1 per cent

Wave length in meters.	DIAMETERS GIVEN IN MILLIMETERS.			
	Advance.	Manganin.	Platinum.	Copper.
100	0.30	0.29	0.13	0.006
200	0.46	0.40	0.20	0.045
300	0.57	0.50	0.27	0.09
400	0.66	0.60	0.30	0.10
600	0.83	0.75	0.37	0.15
800	0.98	0.88	0.42	0.20
1000	1.10	0.99	0.50	0.21
1200	1.20	1.10	0.57	0.22
1500	1.30	1.21	0.63	0.26
2000	1.52	1.38	0.73	0.30
3000	1.82	1.62	0.80	0.33

Frequency = $3 \times 10^8 \div$ wave length

In the case of a wide flat, conductor, such as the earth's surface, the currents which are set up in the surface penetrate into the substance of the conductor according to the specific resistance of the material, permeability, and frequency. The relation between the density of current at the surface and the density at a point distant x below the surface is given

$$i = I_0 e^{-\left(\sqrt{\frac{2\pi\omega\mu}{\rho}}\right)x} \times \sin\left(\omega t - \left(\sqrt{\frac{2\pi\omega\mu}{\rho}}\right)x\right), \dots \quad (3)$$

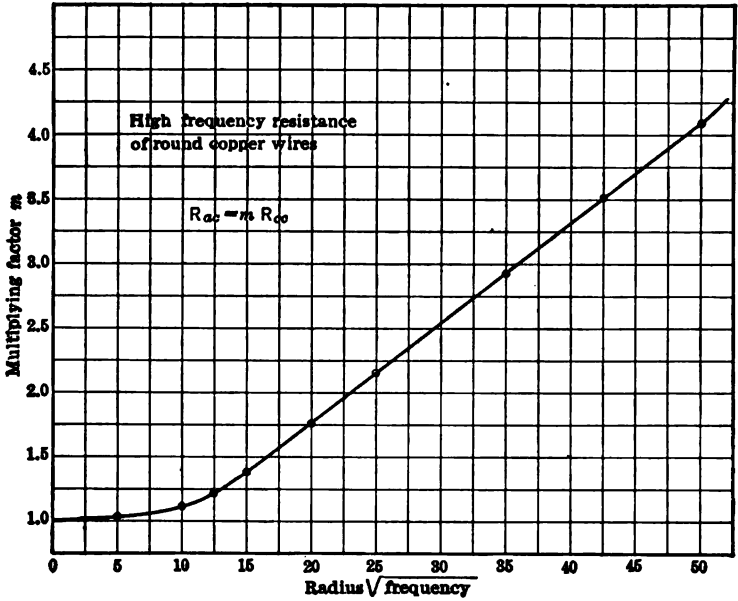

FIG. 3.—Variation of resistance of round, straight, copper wire with frequency and radius.

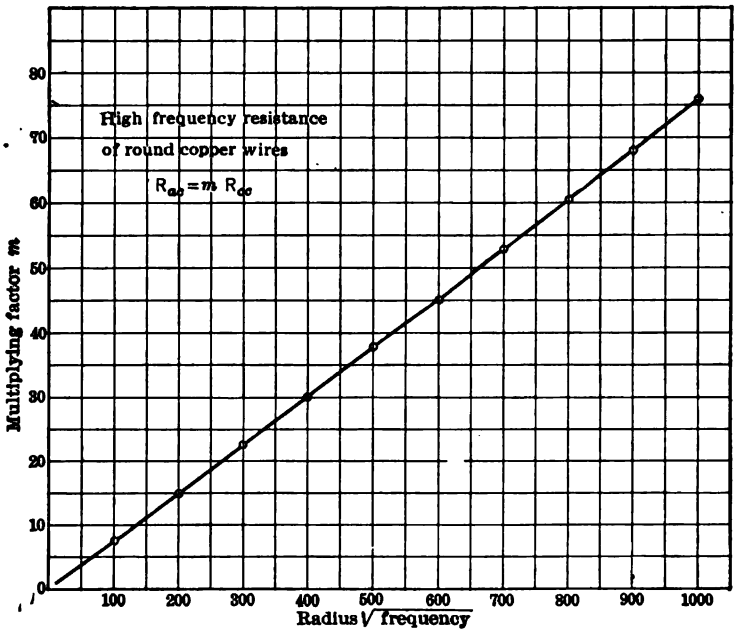

FIG. 4.—Variation of resistance of round, straight, copper wire with frequency and radius.

in which

I_0 = current density at surface;

i = current density a distance x cm. below the surface;

$\omega = 2\pi f$, where f is the frequency of current;

μ = permeability of the substance;

ρ = specific resistance of the substance, abohms per cm^2 .

Not only does the density of current decrease as the distance below the surface is increased but, as indicated by Eq. (3), it reaches its corresponding values at later time than at the surface, this amount of time lag increasing as the depth below the surface is increased. This really means that the current penetrates into the substance with a wave motion; the attenuation is, however, very high, so that probably only a fraction of a wave length is actually set up in the conductor with an appreciable amplitude.

A Simple Analysis of Skin Effect.—Although an exact analysis of skin effect in a conductor requires the theory of wave propagation, and special mathematical series for a solution, a very good idea of its cause (and, what is much more important, its remedy) may be had from the ordinary laws of current flow in inductive circuits. The first thing to notice about the problem is the effect of frequency upon the division of current between two paths in parallel, as shown in Fig. 5, the two paths having equal

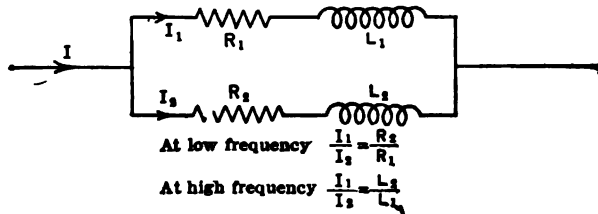

Fig. 5.—For branched circuits the resistance controls the division of current at low frequency whereas the reactance controls the division at high frequency.

resistance but unequal inductance. The formula for the current flow in each path is

$$I = \frac{E}{\sqrt{R^2 + (\omega L)^2}}$$

At very low frequency the ωL term is negligible, and so we have the currents dividing between the two paths inversely as the two resistances, that is, the two currents will be alike. At very high frequency, however, the resistance term becomes relatively negligible and the current divides inversely proportional to the inductance in the two branches. The same

voltage is applied to both paths, so the sum of the resistance reaction and the inductance reaction (added vectorially) in each path must be the same. It is from this standpoint that we will investigate the skin effect in wires.

Imagine a round copper wire carrying current uniformly throughout its cross-section, Fig. 6. The density of magnetic flux at a point *A* on the surface of the wire is given by the formula

$$B_A = \frac{4\pi I}{2\pi a} = \frac{2I}{a}, \dots \dots \dots (4)$$

where *I* = total current in amperes;
a = radius of the conductor in cm.

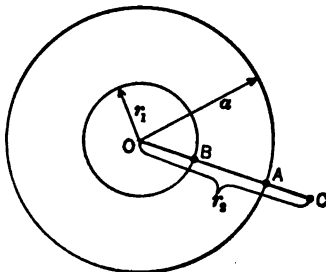

FIG. 6.—Cross-section of wire of radius *a*; magnetic field density to be calculated at points *A*, *B*, and *C*.

At a point *B* inside the conductor, the amount of current producing flux (for of course there is magnetic flux inside the conductor) is only that part of the total current which flows inside the circle inscribed through the point *B*. This amount of current is, for uniform current density, equal to *I* × *r₁²* / *a*². The magnetic flux density at *B* is, therefore, by Eq. (4)

$$B_B = \frac{2I r_1^2}{a^2} \times \frac{1}{r_1} = \frac{2I r_1}{a^2} \dots \dots \dots (5)$$

For a point *C* outside the wire, distant *r₂* from the axis of the wire, the flux density is given by the equation

$$B_C = \frac{2I}{r_2} \dots \dots \dots (6)$$

From Eqs. (4) and (6), the flux density throughout the cross-section of the wire and in the region surrounding the wire may be calculated; Fig. 7 shows the result of such a calculation. In the upper part of the figure the flux is shown in the form of circles concentric with the axis of the wire, the closeness of the circles representing the flux density, and in the lower part of the figure is shown a plot of the flux densities, ordinates being values of flux density and abscissæ being distance from center of wire.

The total flux surrounding any point is obtained by adding the flux from a point infinitely distant from the wire, up to the point in question; a curve showing the value of this flux for different points inside and outside the wire is shown in Fig. 8. The ordinates of the curve are obtained by integrating the density curves of Fig. 7. The flux ϕ_1 , is the total flux produced by the current in the wire, outside of the wire itself, whereas

surrounding any point outside the wire as, e.g., C of Fig. 6, there is a flux equal to ϕ_3 . There is a certain amount of flux inside the wire itself and the flux surrounding the innermost filament is obtained by adding to ϕ_1 this internal flux; it is shown by ϕ_2 in Fig. 8.

Now let us consider the wire made up of a bundle of separate parallel filaments, such a wire as would be obtained by using a cylindrical bundle of very fine wires, each insulated from its neighbor, except at the

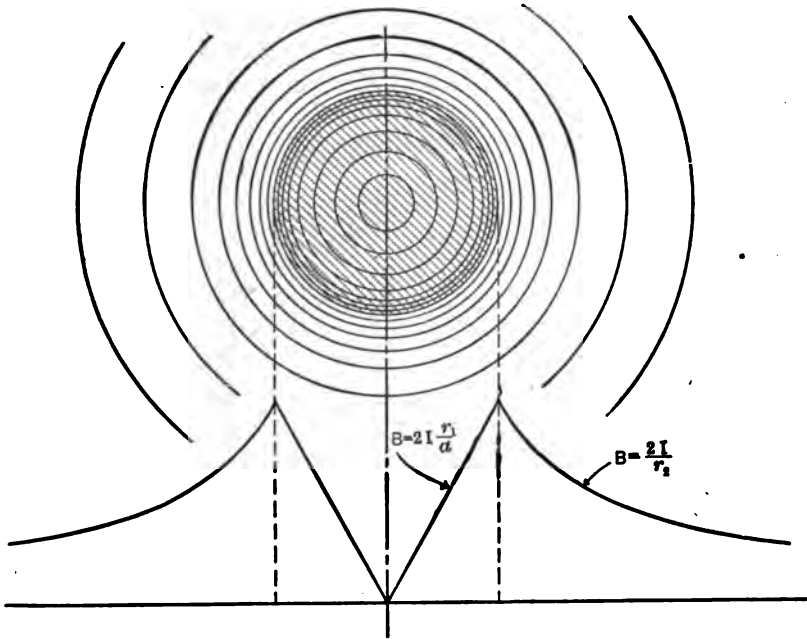

FIG. 7.—Closeness of circular lines show the density of magnetic field around a non-magnetic wire; in lower part of figure magnetic field density is shown by distance from reference line to curve marked B .

ends of the wire in question, where they are all electrically connected together. Let the resistance of each of these filaments be R . If an e.m.f., $E \sin \omega t$, is impressed across the ends of this composite wire, all filaments will have the same impressed e.m.f., and it is therefore evident that the sum of the reactions in each filament must add up (vectorially) to equal this impressed force.

The resistance drop in each filament is IR and the inductance drop is $\frac{d\phi}{dt} = \omega\phi$ where ϕ is the maximum amount of flux surrounding the

filament in question. Hence for two filaments, one at O and the other at A (Fig. 6) we must have

$$E^2 = (I_1 R)^2 + (\omega \phi_1)^2$$

and

$$E^2 = (I_2 R)^2 + (\omega \phi_2)^2,$$

where I_1 and I_2 are the currents in the two filaments considered.

In these equations E , I , and ϕ , must have corresponding values, i.e., either effective values or maximum values.

At very high frequencies the resistance drop is negligible compared to the flux reaction drop, and so we must conclude that, for frequencies which make IR negligible compared to $\omega\phi$, the flux surrounding all filaments of the wire must be the same. Referring to Fig. 8 this statement means that $\phi_2 - \phi_1 = 0$, that is, there is no flux inside the wire itself. If

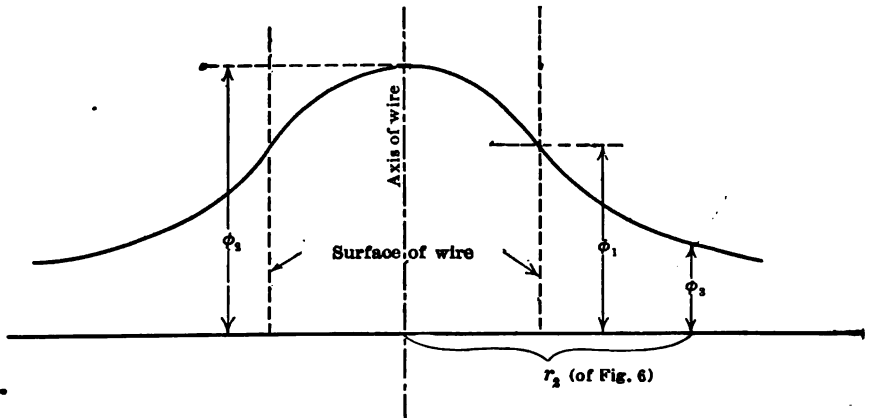

FIG. 8.—Curve showing total flux outside any point considered in Fig. 7.

there is no internal flux the flux density everywhere inside the wire must be zero, and as the flux density at any point in the wire distant r from the axis is equal to $.2I/r$, where I now signifies the current flowing in the wire inside of a circle through the point in question, we must conclude that there is no current anywhere inside the wire.

At ordinary frequencies the resistance drop is not negligible in comparison with the reactance drop, so that the sweeping conclusion of the previous paragraph (no current anywhere inside the conductor) is not true, but it is evident that, as the frequency increases more and more the difference between ϕ_2 and ϕ_1 of Fig. 8 must continually decrease.

If instead of a copper wire an iron wire had been assumed, the internal flux density would have been very much increased so that Figs. 7 and 8 would have more nearly the appearance of Figs. 9 and 10. The value of the internal flux ($\phi_2 - \phi_1$) would be very much increased, so that the

frequency at which the IR drop becomes negligible compared to the $\omega\phi$ drop is much less than for copper wire.

Offsetting this effect to some extent, however, is the fact that the resistance of the iron is greater than that of copper; the result is that iron, while it has a greater skin effect than copper, does not have as much greater effect as the increased value of μ would indicate.

The change in current density throughout the cross-section of wire due to the effect of the internal flux, is indicated (for a certain wire) in

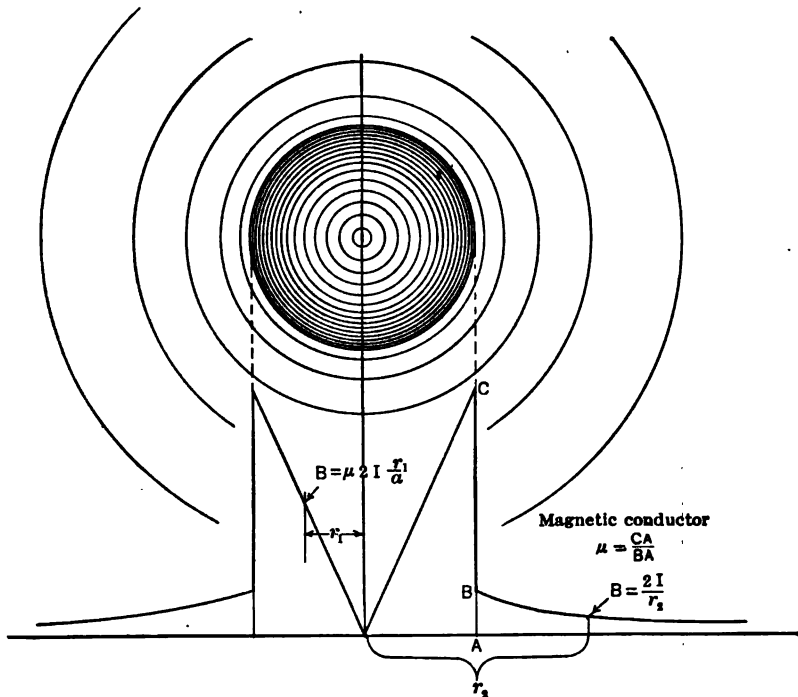

FIG. 9.—Strength of magnetic field in and around a wire of magnetic material.

Fig. 11, the three curves showing how, as the frequency is increased, the current shifts more and more to the outer skin of the conductor. The current density at the surface of the conductors has been assumed the same for the three frequencies.

It is evident from the foregoing discussion that a substance having high specific resistance and low permeability will have the least skin effect; this is shown in Table I on p. 115. The wires used for resistance in making tests and measurements in high-frequency circuits should be made of small wires of the high-resistance alloys, practically all of which have unity permeability.

Elimination of Skin Effect.—One obvious remedy for skin effect is to so construct the conductor that there is no internal flux, or rather that the internal flux is negligible compared to the external flux, which of course produces no skin effect, as it affects all filaments of the wire equally. A

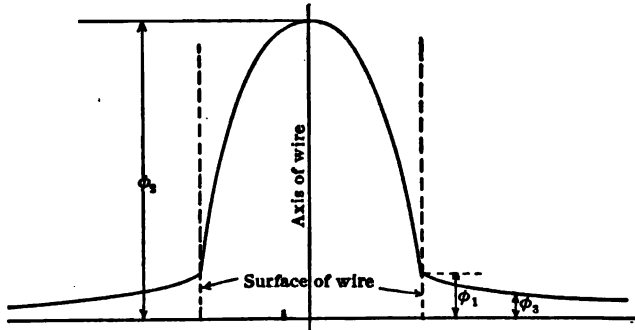

FIG. 10.—Total flux outside any point considered in Fig. 9.

conductor with no internal flux is impossible, but such a condition may be approximated by using a tubular conductor; such a construction is used for high-frequency ammeters designed to carry comparatively large currents (say 25 amperes or more). The current to be measured is carried

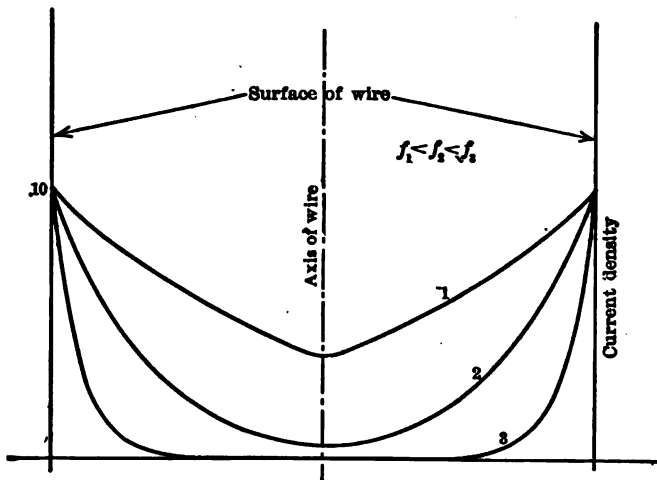

FIG. 11.—Current density in a solid, round, conductor at three different frequencies.

from the connectors of the ammeter to two circular disks, and these disks are connected by a set of very thin high-resistance strips, the whole arrangement having the appearance of a barrel, the thin strips taking the place of the barrel staves. Such a construction is shown in Fig. 12, this showing the construction of a 40-ampere, so-called "hot-wire" meter. As the

radial thickness of these strips is only about .004 cm., there is practically no internal cross-section to the conductor; it is all "skin."

In the scheme ordinarily employed for reducing skin effect the required cross-section of conductor (which depends upon the amount of current to be carried), is made up of a great many small wires, each completely insulated from all the rest; a common form of this cable used for winding radio coils consists of 48 No. 38 enameled wires properly woven together. In eliminating skin effect by this construction it is not sufficient to merely



FIG. 12.—A hot wire ammeter showing how the skin effect is minimized by special arrangement of very thin strips of high-resistance metal.

subdivide the conductor into small well-insulated strands; these strands must be so woven or twisted together that *each strand is as much on the outer surface of the cable as every other one.*

If 48 No. 38 insulated wires are laid loosely together, parallel to one another, it will be found that the increase in resistance due to skin effect is nearly as much as though a solid wire (of the same cross-section as that of the cable) were used. (The stranded cable would be somewhat better than the solid wire, because of its somewhat greater useful outer surface.) It is therefore important in getting the stranded wire (sometimes called

litzendraht) to see that not only is it made up of a great number of well-insulated strands, but also that these strands are properly interwoven. A real braiding process will accomplish the result but a suitably twisted cable is nearly as good. A properly twisted cable must be made up of several component twisted cables to be free from marked skin effect. For 48 No. 38 cable, e.g., three separately twisted cables, each of 16 wires, may be twisted together and the resulting cable will be nearly as good as braided cable.

It is important to note just what effect is to be obtained in making these high-frequency radio cables; the cable must be so constructed that each strand has, per unit length (say per meter) the same flux surrounding it, when each strand is carrying the same current. When the strand is in the center of the cable it has more flux surrounding it than when it is on the periphery, hence each strand must occupy corresponding positions in the cross-section of the cable for equal distances, in order that it may have the same surrounding flux per unit length as all the other strands.

Even in suitably woven cable there is still some skin effect due to the finite size of the strands themselves, each strand in itself having an appreciable skin effect at very high frequencies.

It is important in purchasing radio cable of the kind just described to make tests for the continuous-current resistance. In making this test the enamel must be removed carefully from each strand, at both ends of the piece to be tested, and the strands be well soldered together. The c.c. resistance should be calculated from the total cross-section of copper in the cable and the measured value should approach this very closely. In making cable a strand may break and the operator insert another and continue the process of weaving the cable. But such a broken strand is evidently of no use in carrying current, because one break opens that strand completely, the strand being insulated from its neighbors.

Specifications for radio cable should therefore state not only the size and number of wires to be used, quality of enamel, method of twisting, etc., but should also call for a c.c. resistance within a certain percentage of the theoretical value. The longer the pieces of cable called for, the more likely are breaks to occur, for this reason the cable is generally obtained in lengths of a few hundred feet only. If two pieces of radio cable are to be joined, the greatest of care must be exercised in making the joint; if only half the strands are soldered together (quite likely unless each individual wire is separated from the rest and properly cleaned before attempting to solder the joint) then the resistance of the whole cable is twice as much as it should be.

Skin Effect in Coils.—With the foregoing analysis of skin effect in mind it is at once evident that the redistribution of current throughout the cross-section of a conductor will be greater if the conductor is used

in making a coil than if it is used in the form of a straight wire. The distribution of magnetic flux inside a single layer solenoid is somewhat as shown on Fig. 13; the flux density is high just inside the solenoid and practically zero at the outer surface of the coil. Assuming that this density decreases to zero from the inner surface of the winding to the outer (nearly

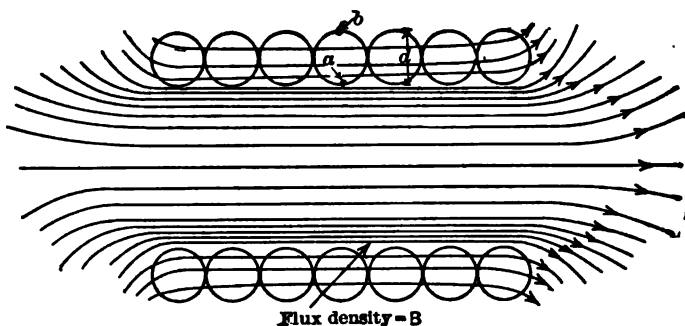

FIG. 13.—Approximate flux distribution inside a short solenoid.

the case for ordinary coils) it is evident that the outer filaments of the wire are linked with much more flux, than are the inner filaments. Thus an imaginary filament on the outside of the wire as at *b*, Fig. 13, will be linked with a flux in excess of that linked with filament *a* by an amount equal to $B/2 \times d$ (where B is the flux density at the inner surface of the winding and d is the radial depth of the winding) per unit length of the wire. It is apparent that the current will tend to crowd into that part of the wire which is on the *inside of the coil*, the inductance reaction being less for the filaments on the inner side of the winding than for those on the outer side.

But besides this tendency of the current to redistribute itself, there

is also the tendency to redistribute about the axis of the wire, and also each conductor exerts a certain effect on its neighbor—these all combine to produce a current distribution about as indicated in Fig. 14, the density of current being indicated by the proximity of the dots.

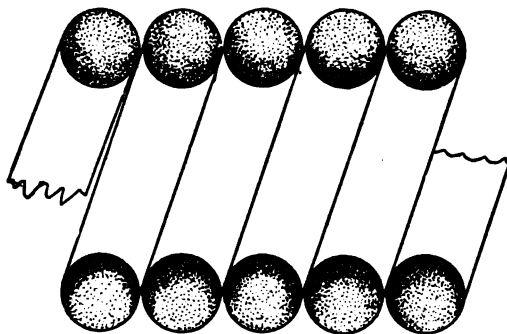

FIG. 14.—Distribution of current in the conductors of a short solenoid; density of shading corresponds to current density.

In constructing variable resistances for use in making radio measure-

ments, skin effect must be carefully considered. The most convenient form of variable rheostat is a cylindrical one with a sliding contact, the almost universal form of laboratory rheostat for ordinary c.c. and a.c. measurements. But this type of winding is not satisfactory for high-frequency currents because of the extra skin effect caused by solenoidal winding and also because the amount of self-induction in such a rheostat is too great to be neglected in radio circuits. Radio cable cannot be used with sliding contact rheostats for evident reasons: solid wire must therefore be used and still the skin effect and self-induction be reduced to a minimum. This is done by winding on a porcelain tube a bifilar high-resistance solid wire; the two wires making the bifilar construction are wound around the cylinder in opposite directions, the two wires crossing each other twice per turn. Such a winding has a self-induction practically zero, and hence has a minimum skin effect.

The increase in resistance of coils, due to skin effect, is a very difficult problem to analyze mathematically; only the simplest cases have been considered, and even then assumptions have been made which make the validity of the equations obtained doubtful.

An experimental investigation of the skin effect in coils was carried out by the author, measurements being made on a Wheatstone bridge, and the results are given herewith; they serve to indicate how much increase in resistance from skin effect may be expected with coils similar in form. The single layer coils were wound on dry wood reels with double cotton-covered wire, the wires being laid as closely together as possible. The length of the winding was 10 cm. and the approximate diameter (the cross-section was actually octagonal) was 10.5 cm. The datum is given in the accompanying table, both self-induction and resistance being given, the results being probably accurate to within 1 per cent unless otherwise stated.

There are two effects which must be kept in mind when interpreting these results; there is an actual increase in resistance due to redistribution of current in the conductor of which the coil is made, and there is an increase in the measured value of resistance due to the effect of internal capacity, explained in the previous chapter when analyzing resonance in parallel circuits.

Every coil has internal capacity due to one part of the winding being equivalent to one plate of the condenser, acting with every other part to form a condenser. It was shown that the apparent resistance of an inductance, shunted with a condenser, increases as the frequency is increased, in accordance with Eq. (48). Although this equation is not directly applicable to these coils (the capacity of which changes with frequency changes) it indicates that the measured value of resistance may be expected to increase entirely aside from any skin effect which may be present. But this effect of capacity which gives an apparent increase in resistance pro-

TABLE II

Coil.....	1	2	3	4	5	6	7	8	9	10	11	12	13	14	15
Size wire...	11	12	14	16	18	20	22	24	26	28	30	32	34	42/36e	48/38e
Number turns...	37	41	54	64	83	96	115	162	188	237	290	345	361	85	97
Frequency in Kilocycles															
.0 R	.0860	.07	.15	.30	.61	1.07	2.10	3.88	7.05	17.2	33.3	59.8	101	1.14	1.53
R	.066	.087	.167	.305	.628	1.11	2.12	3.91	7.22	17.3	33.3	59.8	101	1.20	1.60
.870 L	.0975	.120	.202	.278	.460	.614	.894	1.29	1.78	3.79	5.54	7.79	8.49	.496	.639
R/L	.68	.725	.834	1.09	1.37	1.81	2.38	3.04	4.06	4.57	6.00	7.68	11.9	2.43	2.50
R	.400	.495	.70	.96	1.42	1.86	2.82	5.00	8.30	20.0	35.9	63.1	105	1.42	1.82
.50 L	.0955	.118	.198	.278	.457	.614	.897	1.30	1.78	3.82	5.66	7.88	8.57	.495	.641
R/L	4.20	4.25	3.63	3.45	3.10	3.03	3.15	3.85	4.65	5.23	6.46	8.02	12.3	2.87	2.83
R	.880	.668	1.02	1.43	2.18	2.80	4.14	6.05	9.75	22.8	42.0	77.3	124	1.62	2.18
.100 L	.0942	.118	.199	.279	.460	.617	.897	1.30	1.79	3.86	5.66	8.15	8.90	.498	.644
R/L	6.15	5.65	5.18	5.14	4.75	4.55	4.63	4.65	5.44	5.90	7.42	9.50	13.9	3.24	3.40
R	.735	.84	1.29	1.76	2.96	3.76	5.26	7.74	11.8	31.4	61.0	112	164	2.07	2.39
.150 L	.0947	.118	.199	.278	.460	.616	.898	1.30	1.80	4.00	6.00	8.51	9.26	.500	.647
R/L	7.77	7.22	6.48	6.33	6.22	6.10	5.85	5.96	6.55	7.85	10.2	13.1	17.7	4.13	3.70
R	.803	1.00	1.60	2.17	3.52	4.45	6.75	9.70	16.1	45.0	85.0	157	220	2.26	2.71
.200 L	.0952	.119	.198	.278	.461	.621	.899	1.31	1.84	4.22	6.21	8.70	9.5	.501	.649
R/L	8.45	8.40	8.10	7.80	7.61	7.15	7.52	7.40	8.75	10.7	13.7	18.0	23.2	4.50	4.18

Size of wire to the nearest B. & S. gage number.
 Inductance given in millihenries.
 Resistance given in ohms and ohms per millihenry.

duces at the same time an increase in the *apparent inductance of the coil*, so that in the results of the table any increase resistance which occurs without a corresponding increase in inductance, is due to redistribution of current in the conductor of the coil (i.e., real skin effect); for frequencies high enough to produce an increase in the apparent inductance the skin effect is not alone in producing the increase in resistance, the internal capacity contributing its effect also in increasing the apparent resistance.

It will be noticed that for the larger wires the inductance actually decreases as the frequency increases, for the lower values of frequency.

Illustrating this effect we take the data for coil No. 1 made of No. 11 wire. In the range of frequencies used the inductance decreased with increase of frequency, whereas the resistance increased from .050 ohm to .803 ohm. The radius of this wire is .114 cm. and so the factor, $r\sqrt{f}$ for 2×10^5 cycles, is 51. Referring to Fig. 3 the factor m is found to be 4.2. If, therefore, the wire had been used in the form of a straight conductor, we might have expected an increase in resistance from .050 ohm, the c.c. resistance to $4.2 \times .05 = .21$ ohm. Actually it changes from .05 ohm to .80 ohm, thus showing how the skin effect is augmented when the wire is used in the form of a coil. The superiority of the radio cable, either 42/36s or 48/38s is at once evident from the results given in the table.

If the coil used has more than one layer, the magnetic field density is much greater than it is for a single layer coil, hence we should expect a much greater skin effect for multi-layer coils than for single-layer coils and the experimental results of Table III which were obtained with ten layer coils, prove the point. Thus the single layer coil of No. 18 wire showed an increase in resistance of $\frac{2.18}{.61} = 3.6$ times as the frequency varied from zero to 100,000 cycles. This same wire wound in a 10-layer coil showed an increase through the same range of frequency of $\frac{84}{1.74} = 48$ times so that the resistance increase is 13 times greater when used in a 10-layer coil than when used in a single-layer coil.

It must be noticed also that this great increase in resistance is not due to the internal capacity of the coil. These multilayer coils were built on wooden reels in a special way first described by the author; the construction was such that a considerable air space (in this case .16 cm.) was used between consecutive layers, this construction giving such a low internal capacity that, up to the highest frequency used the inductance of the coil showed but slight increase. These multilayer coils were octagonal in form and had 10 layers each, wound back and forth. Each layer was 2.6 cm., long separated from the next layer by .16 cm. air. The

inner diameter was approximately 10.5 cm. and the outside diameter varied with the size of wire used, being greater for the larger wires.

TABLE III

Coil.....		16	17	18	19	20	21	22	23	24	25	26
Size wire.....		12	18	20	22	24	26	28	30	32	34	48/38a
Number Turns....		100	197	239	300	343	410	586	719	859	898	250
Frequency in Kilocycles												
0	R	.12	1.74	3.30	6.7	11.5	21.3	49	96	172	300	5.1
1.2	R	.48	2.48	3.40	6.8	11.7	21.6	50	96.5	173	300	5.2
	L	1.46	5.21	8.10	12.6	16.7	23.7	48	72	102	117	9.2
	R/L	.33	.48	.42	.54	.70	.91	1.0	1.3	1.7	2.6	.56
10.5	R	3.85	6.27	7.80	11.4	16.2	27	64	122	210	345	6.7
	L	1.42	5.18	8.10	12.6	16.8	24.0	48	73	104	120	9.3
	R/L	2.7	1.2	.96	.91	.96	1.1	1.3	1.7	2.0	2.9	.72
15.4	R	5.50	10.2	11.3	15.4	20.2	32.0	71	126	225	370	7.2
	L	1.39	5.20	8.12	12.7	16.9	24.0	49	74	105	124	9.3
	R/L	4.0	1.9	1.4	1.2	1.2	1.3	1.5	1.7	2.1	3.0	.77
25	R	7.40	21.0	22.3	25.7	28.5	42	97	194	360	600	8.5
	L	1.37	5.20	8.14	12.8	17.1	24.5	51	78	116	138	9.3
	R/L	5.4	4.0	2.7	2.0	1.7	1.7	1.9	2.5	3.1	4.3	.91
50	R	10.9	48.0	63.5	78	82	100	200	465	1080	1450	15
	L	1.37	5.22	8.17	13.2	17.7	25.3	55	87	131	150	9.5
	R/L	7.9	9.1	7.8	5.9	4.6	4.0	3.6	5.3	8.2	9.7	1.6
75	R	14.1	73.0	94	155	133	172					19
	L	1.37	5.23	8.22	13.6	18.6	27.5					9.7
	R/L	10.3	14.0	11.4	11.4	7.2	6.2					2.0
100	R	16.6	84	142	267	268	415					37
	L	1.38	5.27	8.55	14.3	20.3	30.6					10.4
	R/L	12.0	15.9	16.6	18.7	13.2	13.6					3.6
125	R	18.8	104	190	362	462						61
	L	1.37	5.32	9.07	15.1	21.0						10.8
	R/L	13.7	19.5	21	24	22						5.6
150	R	20.5	124	280	550	840						115
	L	1.38	5.56	9.30	15.7	22.0						11.4
	R/L	14.9	32.3	28	35	38						10

The great increase in resistance of coil No. 16 for example is really due to a redistribution of current throughout the cross-section of the conductor. Although the resistance increases 217 times in the frequency range used the inductance is lower at the highest frequency than at the lowest. There are cases shown in which the increase in apparent resistance increases very rapidly for the higher frequencies, even with small-

sized wire. Thus the 10-layer coil wound with No. 26 wire increased its resistance from 21.3 ohms to 415 ohms, but at the same time the inductance increased from 23.7×10^{-3} henries to 30.6×10^{-3} henries. Hence for this coil the internal capacity was making itself felt so that the actual increase in apparent resistance must be regarded as due to the combined effect of redistributed current and internal capacity.

Three of the coils were wound with radio cable; in two of them there were used 48 No. 38 enameled strands in the cable—three twisted cables, each having 16 strands, were twisted together to make the cable. The solid wire most nearly approaching this cable in cross-section was No. 22. In the single-layer coils the solid wire increased its resistance by 220 per cent, and this radio cable coil increased by 72 per cent, only one-third as much increase as for the solid wire over the same range of frequency. In the multilayer coil the solid wire increased its resistance from 6.7 ohms to 267 ohms, an increase of 40 times as the frequency was varied from zero to 100,000 cycles whereas the multilayer coil wound with the radio cable increased (in the same range of frequency) from 5.1 ohms to 37 ohms, an increase of only 7.2 times, that is, the stranded wire coil showed a resistance increase due to skin effect only one-sixth as great as the nearest size solid wire. In this resistance increase there is some effect due to the internal capacity of the coil, and if this effect (which is approximately the same in amount for both coils) were taken into consideration the superiority of the radio cable over the solid wire would be even more striking.

From the results presented in Tables II and III there was calculated for each coil the "ohms resistance per millihenry" and the results are presented in the form of curves in Figs. 15 and 16. The most interesting conclusion to be drawn from these curves is the idea that the higher the frequency the smaller the wire should be to keep the ratio of resistance to reactance low. Thus in the single-layer coil it is evident that below 40 kilocycles No. 16 wire is better than No. 20 (such factors as cost, bulk, current-carrying capacity, etc., not considered) but above this frequency No. 20 wire is better than No. 16.

For the multilayer coils this feature is shown to a much greater degree and at lower frequencies; thus at 1200 cycles No. 34 wire has about 8 times as many ohms per millihenry as No. 12, but at 15 kilocycles the No. 12 wire has more resistance per millihenry than has the No. 34 wire.

The multilayer coil of radio cable is indicative of what a good coil should be; its reactance at 75 kilocycles is 220 times as much as its resistance and this ratio holds over a wide range of frequency. Other coils have been built by the author, using better stranded wire, more of it, keeping the radial depth of conductor low, which showed a reactance 450 times as great as the resistance at 50 kilocycles. The ideas to be kept

in mind in building good radio coils are to use carefully stranded and insulated cable, keep the radial depth of conductor small, keep the coil as compact as possible and at the same time to keep the internal capacity low, and avoid dielectric losses.

In Fig. 17 is shown the construction of a coil which has about 10 millihenries inductance and 7 ohms resistance at 50,000 cycles; sufficient air space was used between layers to keep the internal capacity to about 120 micro-microfarads. This coil operated satisfactorily when carrying

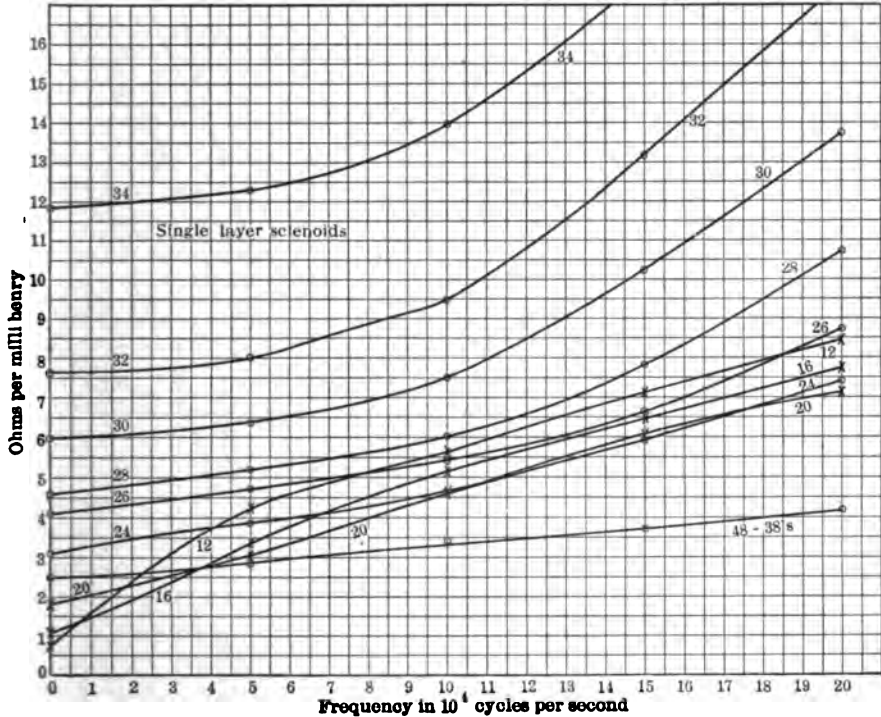

FIG. 15.—Variation of resistance with frequency in single layer solenoids of various wires.

4 amperes with 12,000 volts across its terminals. If it were used in a good insulating oil it would probably be satisfactory when carrying 200–300 kilovolt amperes, although in this case its internal capacity would be more than doubled.

To illustrate in as striking a manner as possible the skin effect which may be present in poorly designed coils tests were made on two coils made of copper strip, wound edgewise. The first coil had 29½ turns of strip 1½ in. wide and 1/8 in. thick; the spacing between successive turns was nearly 1/8 in.; its inside diameter was 14¾ in. and outside diameter was 17¾ in. Its resistance for continuous current was .013 ohm and at 150

kilocycles it had 3.44 ohms resistance, an increase of 285 times. The second coil had $34\frac{1}{2}$ turns of strip 1 in. wide and $\frac{1}{16}$ in. thick, spacing between turns was nearly $\frac{1}{8}$ in. The c.c. resistance was .020 ohm and at 150 kilocycles it was 7.86 ohms, an increase of 393 times. These two examples bring out forcibly the fact that the radial depth of the conductor in a coil intended for radio circuits must be kept small. Further data on these two coils are given in Table V, p. (147).

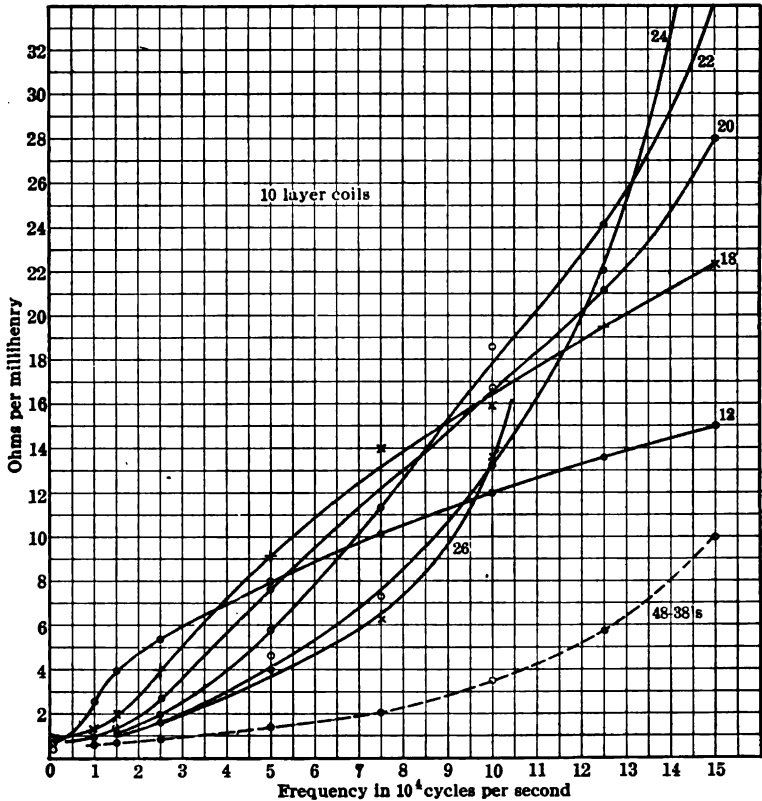

Fig. 16.—Variation of resistance with frequency of multilayer coils; short coils of ten layers each, air space between layers.

Effect of Neighboring Circuits on the Resistance of a Coil—Tuning These Circuits.—It has been shown in the previous chapter that the resistance of a circuit is always increased by the presence of neighboring circuits in which induced currents flow. The power for supplying the losses in these circuits must be furnished by the coil inducing the current and so this effects an apparent increase in the resistance of this coil; the amount of this increase is given by Eq. (73), page 86. This increase in resistance evidently depends upon the tuning of this second circuit. If in

Eq. (73) the reactance of the second circuit is put equal to zero the apparent increase in the resistance of the first circuit may be very great; the curves illustrating this effect were shown in Fig. 91, Chapter I.

As an instance of the losses occurring in neighboring circuits it is interesting to note that one of the terminal posts of the coil pictured in Fig.

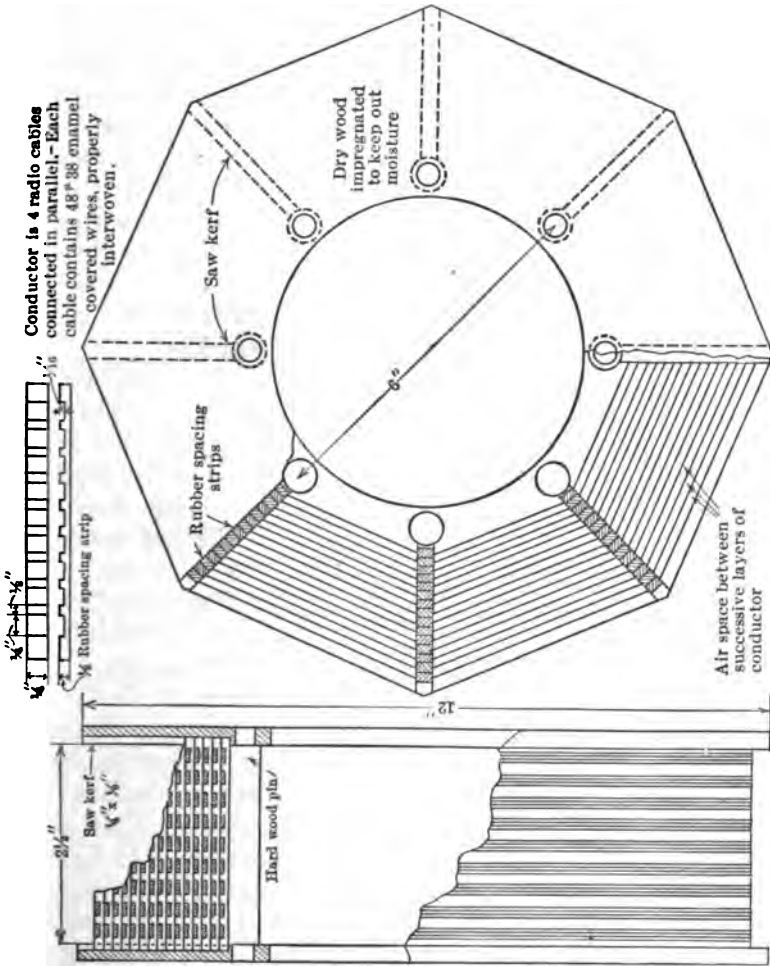

Fig. 17.—Proper construction of coil for high powered high frequency circuits.

17 was fastened on a piece of hard rubber, and this rubber block was fastened to the wood-end piece of the coil with small iron screws. When operating this coil with four amperes at 50 kilocycles flowing in the winding the heat generated in those screws was such that they burned themselves free from the wood after the coil had been in the circuit but a short time.

Resistance of Iron-core Coils.—It was at first thought impossible to use iron-core coils for the high frequencies employed in radio circuits, but such is not actually the case, although the gain in using iron is not so great for radio frequencies as it is for ordinary low frequencies. The difficulty in making efficient iron-core coils for high-frequency circuits is a two-fold one, the apparent permeability of the iron is much less than it should be, and the losses in the iron core greatly increase the effective resistance of the coil. Both of these undesirable effects are due to the same cause; the increase in resistance due to iron loss is mostly caused by eddy currents in the iron laminae, and these same eddy currents serve to keep the magnetic flux from penetrating and so make only the outer parts of the laminae

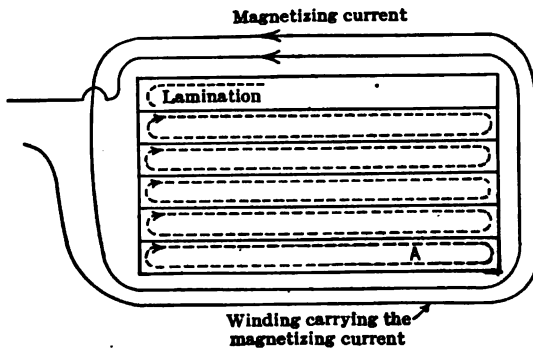

FIG. 18.—Eddy currents occurring in a laminated iron core.

useful as flux carriers. There is also some iron loss due to hysteresis, but this is small compared to the eddy-current loss.

The paths of the eddy currents in the laminae of an iron core are indicated in Fig. 18, the laminae being shown much thicker, of course, than they really are. The direction of the eddy currents, it is to be noticed,

is opposite to that of the current in the winding hence at any point *A* in the center of a laminae, the magnetomotive force acting is really that produced by the winding diminished by a certain amount due to these eddy currents. At low frequencies the back m.m.f. of these eddy currents is negligible compared to that of the main magnetizing coil, so that the flux density in the lamina is nearly constant throughout its cross-section and is about the same as it would be were no eddy current present. At higher frequencies, however, the eddy-current effect becomes increasingly greater, so that at radio frequencies the full value of magnetic flux exists only on the outer surface of the iron; in the inner parts the flux density decreases and it may be practically zero at a depth only a small fraction of a millimeter from the surface of the iron.

The strength of the eddy currents decreases with the thickness of the laminations; the plates used for the cores of radio coils should be only a few hundredths of a millimeter thick. To get the benefit of lamination it is essential that the plates be well insulated from one another, either by a fine quality of varnish or thin paper, or both. The burred edges of

the plates, caused by imperfect fit of the punch and die used in making the plates, is especially bad in causing eddy currents.

The flux density in the steel plates has about the distribution shown by Fig. 19, the penetration of magnetic flux into an iron sheet decreases as frequency increases, increases with the specific resistance of the iron, etc., in fact follows the same distribution law as the penetration of current itself into a conducting medium given in Eq. (3). Because of this lack of penetration the apparent permeability of the iron decreases as the frequency increases, resulting in a decrease in the self-induction as the frequency increases. The curves given in Fig. 20 show how the resistance and inductance of a laminated iron-core coil change as frequency changes. It will be noted that the increase in resistance is practically all due to eddy-current losses; the hysteresis loss is nearly negligible.

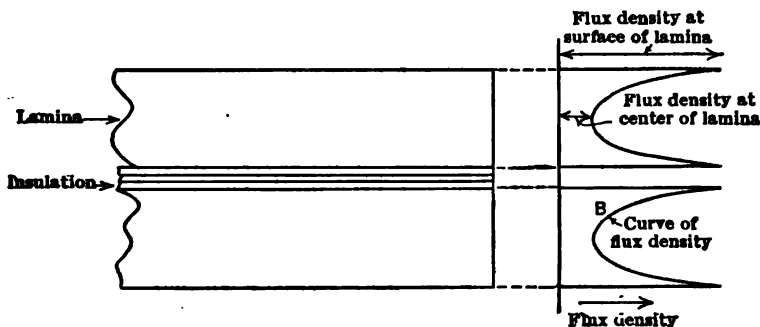

Fig. 19.—Flux density variation throughout the section of a lamination of an iron core; the higher the frequency the greater is the variation in flux density.

It is evident that iron of the quality used in this coil must be used in laminations less than .0075 cm. (the thickness of those in the test coil) to maintain a low resistance at high frequency. The decrease in inductance of this coil is comparatively small in the range of frequencies used.

In Fig. 21 are shown the variations in L and R of another toroidal coil, using thicker laminations. Even for the comparatively low frequencies used in this test the decrease in inductance is very pronounced.

Iron dust, suitably prepared, makes very excellent material for the cores of coils intended for high-frequency use, having very low eddy-current loss. It has, in common with all iron cores, the disadvantage of a permeability varying with magnetic density. A dust-core coil (toroid) was tested to show this effect and gave the results shown in Fig. 22; the measurements were carried out at a frequency of 2000 cycles. In Fig. 23 are shown the characteristics of this same coil measured at various frequencies. The ratio of reactance to resistance brings out very well the fact that a coil is always most efficient at some certain frequency.

It is to be noticed for all these iron-core coils that, at radio frequency,

the resistance of the copper wire is negligible compared to the resistance caused by iron losses, hence it is of little use to employ for the winding a wire as large as those used in winding the coils whose characteristics are shown in the foregoing figures. A very fine wire may be profitably used for the windings then a large number of turns (hence high L) may be put on a very small core—using an iron-dust toroidal core, the outer diameter of the toroid being 5 cm. and the core itself being slightly over 1 cm.

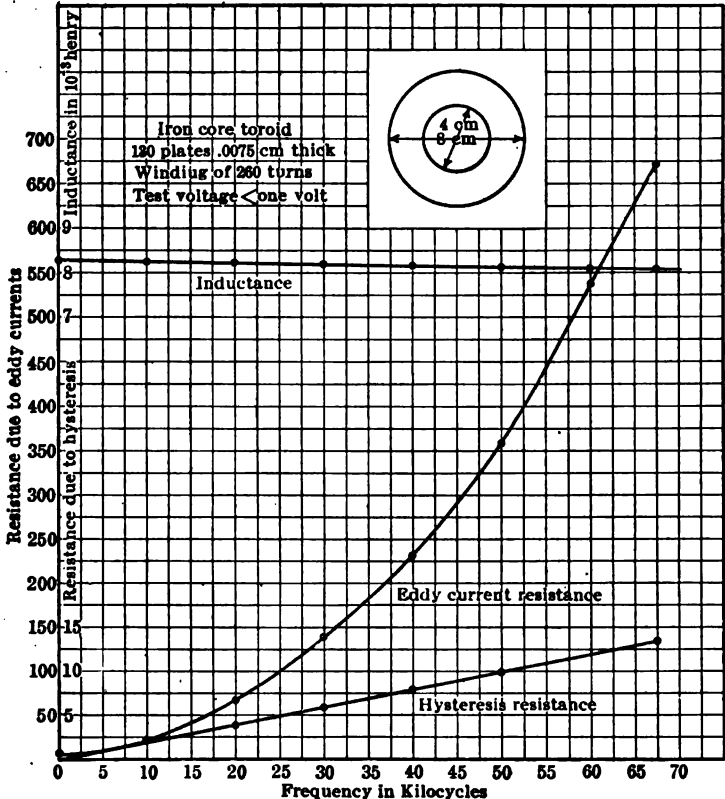

FIG. 20.—Characteristics of a toroidal shaped coil having laminated iron core.

in diameter, winding with fine wire, it is possible to make a coil with an inductance of about 0.25 henry, and having low enough internal capacity to be efficient at 60,000 cycles. Such coils are very convenient for the plate circuit of amplifying tubes, as they are very compact, and are not subject to outside disturbances, a toroid having practically zero mutual induction with any other circuit.

Resistance of Spark and Arc.—In radio circuits there is frequently used an arc, or a spark gap; the resistance of which affects the operation

of the set and must be considered when getting decrement, losses, etc. The resistance of a spark gap varies with many factors, principally the length of gap and magnitude of current through the gap. Within the ordinary range of currents used in radio circuits the resistance of an arc or spark, for constant length of gap, varies inversely with the current to some

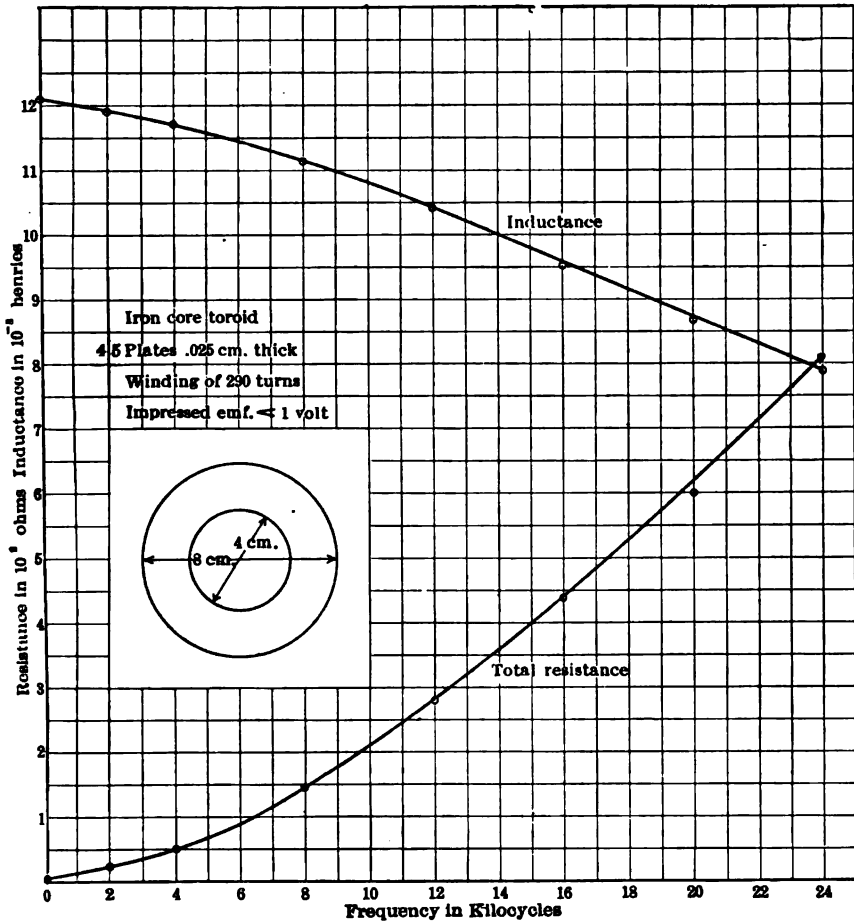

FIG. 21.—Characteristics of a toroidal shaped coil having laminated iron core, laminations being much thicker than those of Fig. 20.

power higher than the first, in such a way that the IR drop actually decreases with an increase of current. Other factors affecting the resistance of the gap are the nature of the gas through which the arc or spark is passing and the material of which the gap terminals are made. Silver and copper electrodes give a higher resistance gap than such metals as

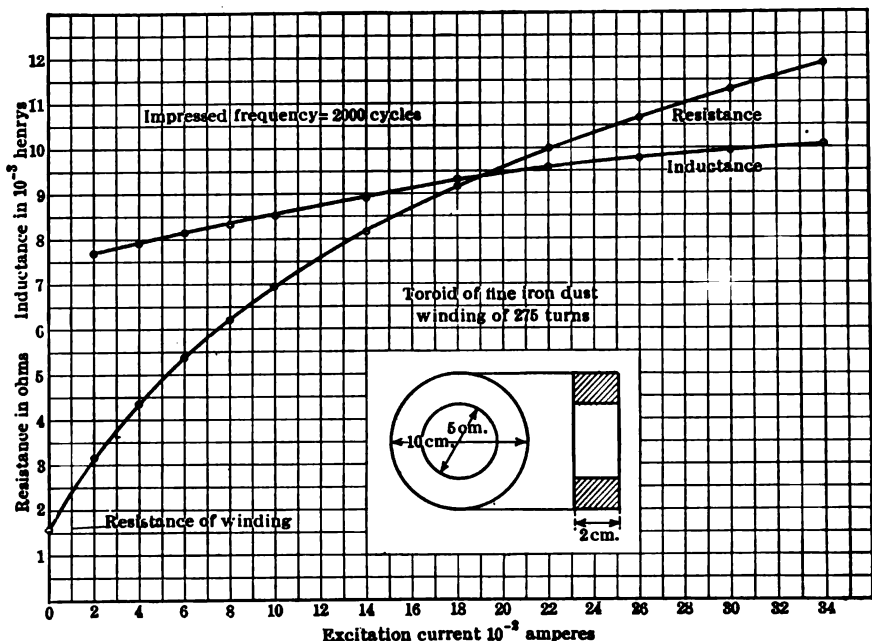

FIG. 22.—Variation of inductance and resistance of a coil having iron dust core, showing increasing permeability with increasing current.

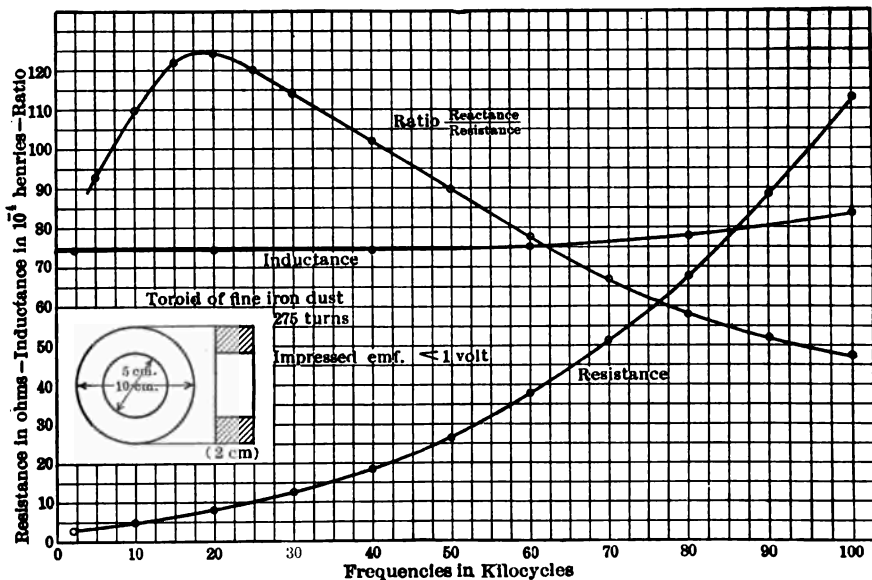

FIG. 23.—Effect of frequency upon the characteristics of a toroidal coil having a core of fine iron dust.

zinc, magnesium, etc.; hydrogen and illuminating gas give a higher resistance than air.

Experiments indicate that for such currents and gaps as are used in radio sets the resistance (effective) of a spark gap is not more than 1 ohm, and is generally only a few hundredths of 1 ohm. This value of resistance is obtained from the heating effect, and so gives a kind of average value of the resistance during the cycle. For low frequencies the resistance of an arc or spark varies a great deal throughout a cycle of current, and it probably does (even if to a less extent) at radio frequencies.

In Fig. 24 is shown the oscillogram giving the form of voltage across an arc and the current through the arc; if the resistance is defined as the ratio of volts to amperes it is evident that the resistance varies through widely differing values during the cycle.

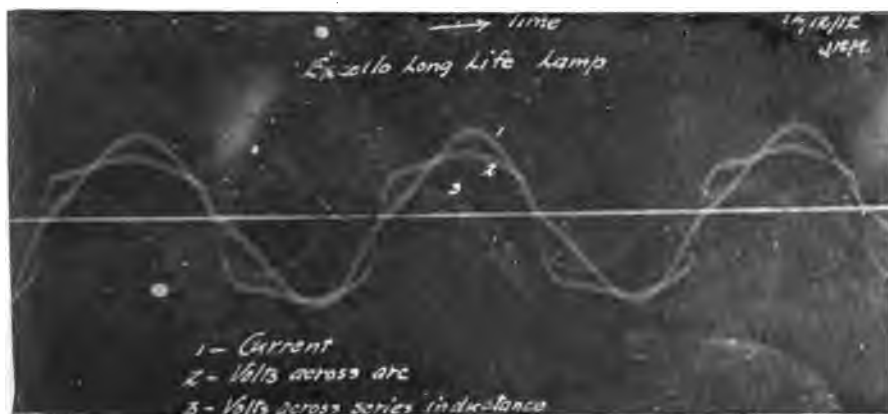

FIG. 24.—A sine wave of e.m.f. impressed across an arc in series with an iron core inductance gave voltage and current forms as shown.

In most radio circuits the resistance which assumes importance is that offered to alternating currents, rather than the continuous-current resistance. Nearly all circuits offer a greater resistance to the flow of alternating current than they do to continuous current, but the arc is an exception to this rule. The relation of current and potential difference in a certain arc is shown in Figs. 25 and 26; from the curves it is evident that increasing current requires less and less potential difference across the arc. The resistance of the arc for continuous current varies from 50 ohms to 2 ohms, according to conditions. Now the alternating current resistance must be determined by the ratio of the voltage change to the current change, i.e., $R = dv/di$, and from these curves it is evident that when dv is positive di is negative, so that the alternating-current resistance of the arc is *negative*. This negative resistance for alternating currents is

characteristic of nearly all circuits in which gas of some kind takes part in the conduction of the current; in some special cases even a pure electron stream may have a negative resistance for an alternating current, as will be explained when discussing vacuum tubes.

The magnitude of this alternating current arc resistance varies somewhat with frequency, it becoming less as the frequency increases.

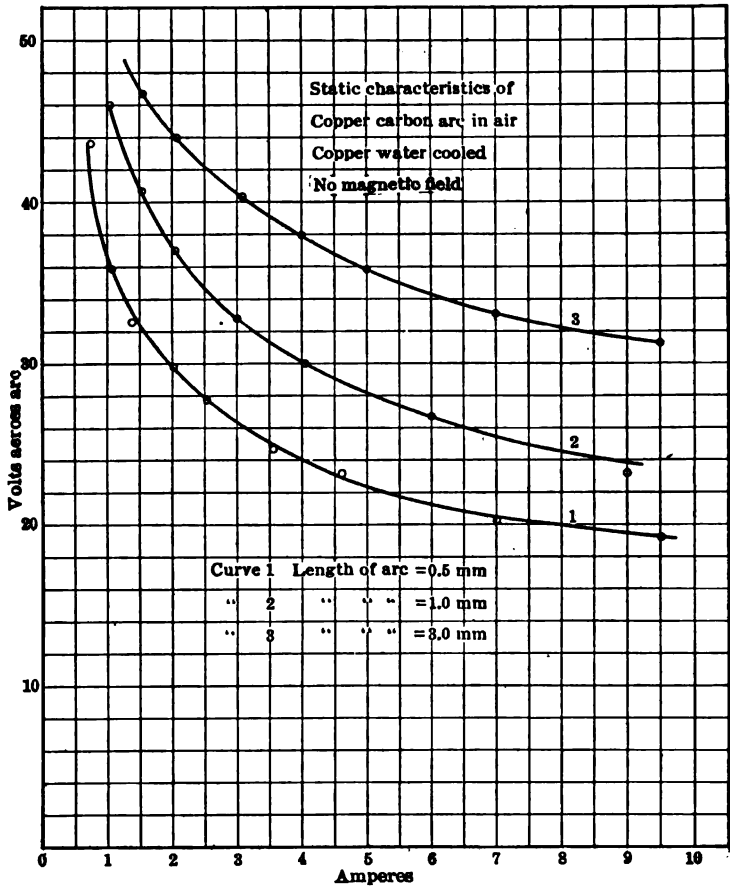

FIG. 25.—Resistance of small arc, in air.

Resistance of an Antenna.—An antenna is a circuit consisting of a capacity, inductance, and resistance in series, the resistance being fixed in value by many effects, among them the radiation of power from the antenna in the form of electro-magnetic waves. The surface of the earth generally forms one plate of the condenser and the over-head wire system the other, Fig. 27. When current circulates in the antenna, losses occur

in the network of wires and in the earth due to actual heat loss produced by the conduction currents; losses occur due to induced currents in guy wires, etc.; losses occur in the earth's surface and any other dielectrics in the field of the condenser such as trees, etc., and power is radiated. That

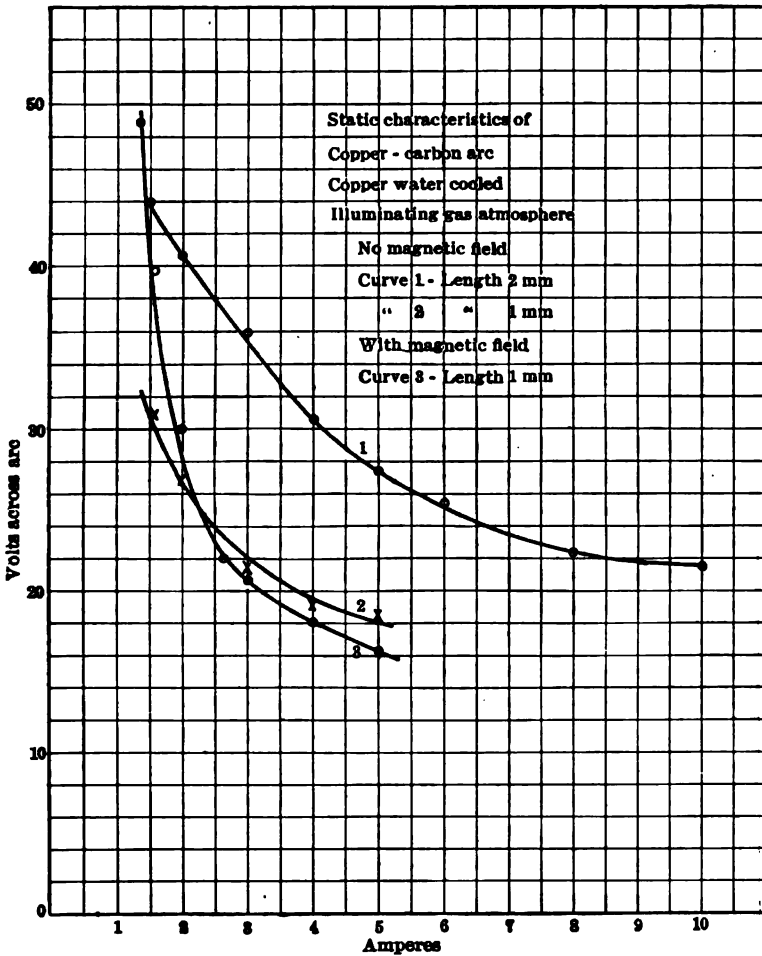

FIG. 26.—Resistance of small arc in illuminating gas, showing also the effect of a transverse magnetic field.

resistance caused by radiation is the only useful resistance; the other factors increase the resistance of the antenna but perform no useful function.

The resistance of an antenna varies with the frequency about as indicated in Fig. 28. With very high frequencies the resistance is high; it decreases to a minimum at a frequency about twice that of the natural

oscillation of the antenna (without any added inductance) and then rises gradually, the amount of this rise being determined principally by dielectric losses in objects located in the electrostatic field of the antenna.

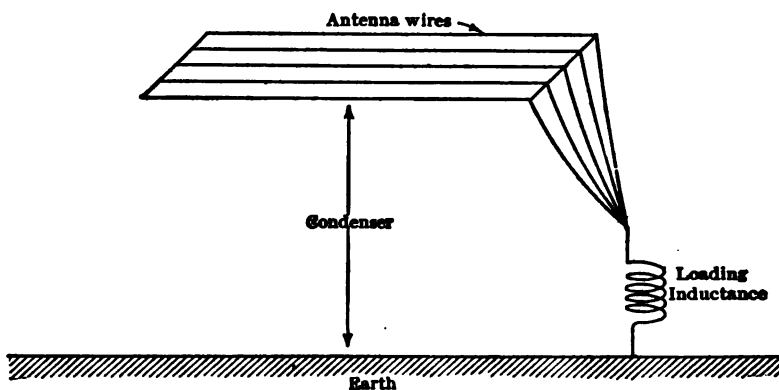

FIG. 27.—Antenna with loading inductance.

For small land antennæ the minimum on the curve may be 20–30 ohms, for aeroplane antennæ perhaps 5–10 ohms; for ships' antennæ 3–6 ohms, and for the large antennæ used for long distance communica-

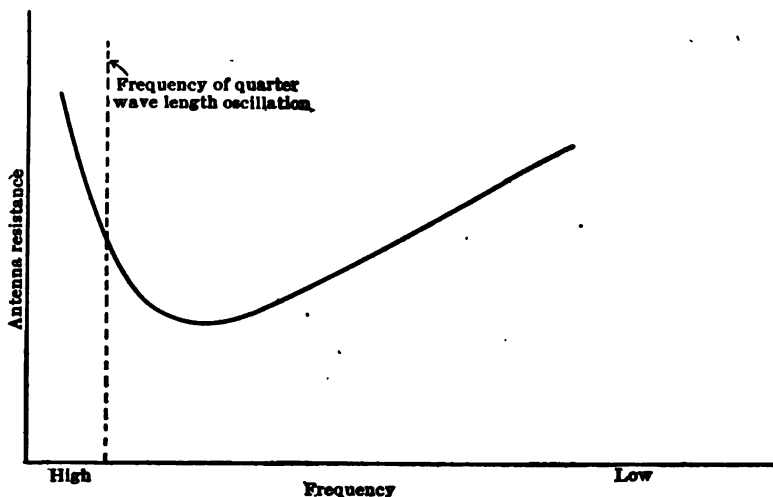

FIG. 28.—Typical resistance curve for an antenna, showing variation with frequency.

tion the minimum value may be 1–2 ohms. The more complete discussion of antennæ and their characteristics will be given in Chapter IX.

Resistance due to dielectric loss and corona loss will be treated in the section dealing with capacity.

INDUCTANCE

Self-induction

Coefficient of Self-induction. Units.—The ordinary unit of self-induction, the henry, is much too great to serve for radio work; instead there are used the millihenry (10^{-3} henry) the microhenry (10^{-6} henry) and infrequently the centimeter (10^{-9} henry). The microhenry is most commonly used.

The fundamental viewpoint from which to consider the self-induction of a circuit is that of the amount of energy stored in the magnetic field of the circuit. This energy is given by the well-known formula, $\text{Energy} = LI^2/2$, where the energy is measured in joules, the current in amperes and L is the coefficient of self-induction in henries. From this equation we can get the definition that the coefficient of self-induction of a circuit in henries, is numerically equal to twice the number of joules stored in the magnetic field when the current in the circuit is one ampere. Hence any conditions which affect the magnetic energy in a circuit, the current staying fixed, must affect the coefficient of self-induction.

A piece of iron introduced into the magnetic field decreases the reluctance of the magnetic path, increases the flux and hence the magnetic energy, and therefore increases the L of the circuit. If a neighboring closed circuit is so placed that current is caused to flow in it by an alternating current in the coil in question, this induced current will be nearly in phase opposition to the current in the first circuit. Flux which is produced by A (Fig. 29) and which threads circuit B is opposed by the m.m.f. of the current induced in B , and hence the reluctance of this part of the magnetic path of coil A is increased. This decreases the flux produced by a given current in A and so proportionately decreases the L of coil A . It is evident that the closer circuit B is placed to circuit A , the more effect will its counter m.m.f. have on the amount of flux produced by A , and hence the more effect it will have in decreasing the L of coil A .

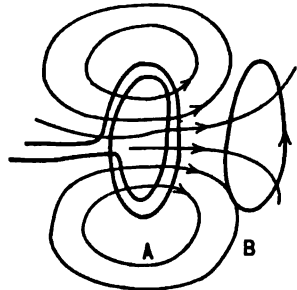

FIG. 29.—When the current in circuit A is varied current will flow in circuit B , affecting thereby the resistance and inductance of circuit A .

If by any means the current in B is made to lead the induced voltage of coil 2 by 90° (as may be nearly done by putting a suitable

condenser in series with the circuit) then the m.m.f. produced by *B* occurs in such phase as to help the m.m.f. of coil *A* and hence produce an increase in the magnetic energy of *A* for a given current, thus the presence of coil *B* actually increases the effective self-induction of coil *A*. These effects were analyzed in the previous chapter and are calculable from Eqs. (85), etc., pages 91 et seq.

It is evident, therefore, that the *L* of a circuit may vary with frequency, current amplitude, current distribution, etc., and that its changes can best be predicted by examining in each case the distribution and density of the magnetic field produced by one ampere of current in the circuit; the value of *L* (in henries) of the circuit is equal to twice the number of joules of energy stored in this field. The derivation of the amount of the magnetic energy is difficult and tedious except in the most simple cases; it will not be attempted here, but the formulæ themselves for the circuits most generally used in radio work will be given in comparatively simple form, the accuracy being for most cases better than 1 per cent. For exact formulæ the student should consult the various publications on the subject, notably those of the Bureau of Standards.

Self-induction of a Single Straight Vertical Wire Distance from all Other Conductors—

$$L = 2l \left(\log \frac{2l}{r} - \frac{3}{4} \right), \text{ cm.} \quad \dots \dots \dots (7)$$

where

- l* = length of wire in cm.;
- r* = radius of wire in cm.;
- L* = coefficient of self-induction in cm.;
- log = logarithm to the base *e*, as it is for all the succeeding formulæ.

Eq. (7) assumes the material of the wire to have a permeability of unity. For uniform current distribution, and permeability differing from unity,

$$L = 2l \left(\log \frac{2l}{r} - 1 + \frac{\mu}{4} \right) \text{ cm.} \quad \dots \dots \dots (8)$$

where

- μ* = the value of the permeability.

For a Single Horizontal Wire—

$$L = 2l \left(\log \frac{2h}{r} + \frac{1}{4} \right) \text{ cm.} \quad \dots \dots \dots (9)$$

where,

- l* = length in cm.;
- r* = radius of wire in cm.;
- h* = height of wire, above earth, in cm.

For a Single Circular Turn of Round Wire.—

$$L = 4\pi R \left[\left(1 + \frac{r^2}{8R^2} \right) \log \frac{8R}{r} + \frac{r^2}{24R^2} - 1.75 \right] \text{ cm., . . . (10)}$$

where, R = radius of turn, to center of conductor, in cm.;
 r = radius of cross-section of conductor.

For a Single Layer Solenoid, Closely Wound.—

$$L = 4\pi^2 R^2 n_1^2 l K \text{ cm., (11)}$$

where R = radius of coil, to center of wire, in cm.;
 n_1 = number of turns of wire per cm. length;
 l = length of winding in cm.
 K = summation of a certain series, which series depends upon the form of the coil. These series have been summed by H. Nagaoka and are given in Table IV. The value of K is given in terms of $\frac{2R}{l}$, i.e., the ratio of the coil diameter to the coil length.

TABLE IV

Diameter Length	K	Diameter Length	K
.00	1.000	.95	.700
.05	.979	1.00	.688
.10	.959	1.10	.667
.15	.939	1.20	.648
.20	.920	1.40	.611
.25	.902	1.60	.580
.30	.884	1.80	.551
.35	.867	2.00	.526
.40	.850	2.50	.472
.45	.834	3.00	.429
.50	.818	3.50	.394
.55	.803	4.00	.365
.60	.789	4.50	.341
.65	.775	5.00	.320
.70	.761	6.00	.285
.75	.748	7.00	.258
.80	.735	8.00	.237
.85	.723	9.00	.219
.90	.711	10.00	.203

The values of K given in the table assume a current distribution uniform throughout the conductor, and so give too large a value of L , if, due to skin effect, the current concentrates in the inner side of the winding. The decrease in induction due to this effect is shown in Table V, in which are tabulated the experimentally determined inductances and resistances of the two edgewise-wound ribbon coils referred to on p. 132, and pictured in Fig. 30. It may be found by calculation from the figures given that at high frequencies the current is practically concentrated in the inner side of the coil.

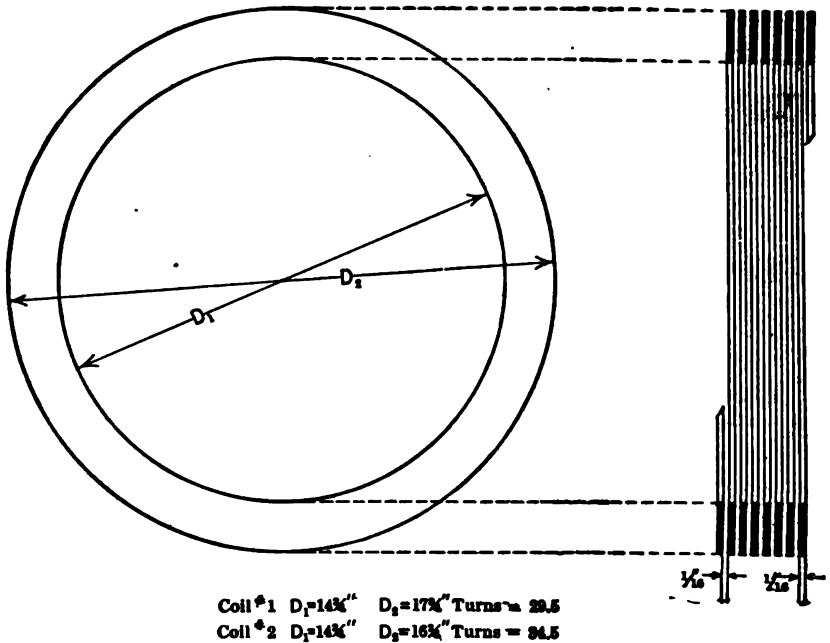

FIG. 30.—Short solenoid made of edgewise-wound copper ribbon.

Best Form of Solenoid.—It may be seen from a few calculations, using Eq. (11), that a given amount of wire, to be wound into a single layer solenoid, should have a certain form if the maximum inductance is to be obtained. This occurs when the diameter is 2.45 times the coil length. The variation of L with departure from this form is not great, however; thus if the ratio is made as low as 1.5 or as high as 4.5 the decrease in L (for fixed length of wire), is only 3 per cent.

Two layer solenoids, one layer wound directly on the other, are not feasible for radio work, as the internal capacity is so high. They are sometimes used, the turns being arranged in a so-called "banked" wind-

ing. Multilayer coil are, however, preferable, but they must be built in such a way as to keep the internal capacity low, as described on p. 133.

TABLE V

RESISTANCE AND INDUCTANCE OF EDGEWISE-WOUND RIBBON COILS

Coil No. 1

Frequency in 10 ³ cycles.....	.043	.088	.128	.248	.338	.450	.730	1.250	3.50
<i>L</i> in 10 ⁻⁶ henry....	489	485	482	476	472	470	466	464	460
<i>R</i> in 10 ⁻³ ohm.....	13	15	19	26	31	36	46	72	176

Frequency in 10 ³ cycles.....	7.00	16.4	25.2	50.0	75.0	100	125	150
<i>L</i> in 10 ⁻⁶ henry....	458	455	452	451	454	457	456	460
<i>R</i> in 10 ⁻³ ohm.....	295	725	945	1345	1775	2205	2745	3440

Coil No. 2

Frequency in 10 ³ cycles.....	.043	.100	.150	.200	.300	.400	.600	1.000	1.60	2.44
<i>L</i> in 10 ⁻⁶ henry....	613	608	604	602	598	595	592	585	585	583
<i>R</i> in 10 ⁻³ ohm.....	23	25	26	30	40	45	49	70	100	145

Frequency in 10 ³ cycles.....	3.50	6.46	15.3	21.5	50	75	100	125	150
<i>L</i> in 10 ⁻⁶ henry....	581	578	574	572	570	568	568	570	572
<i>R</i> in 10 ⁻³ ohm.....	245	495	1095	1345	2640	2940	3730	5280	7860

Inductances of a Flat Spiral, of Ribbon Conductors, Wound Flatwise, Turns Close Together.—

$$L = 4\pi Rn^2 \left[\left(1 + \frac{3b^2 + d^2}{96R^2} \right) \log \frac{8R}{\sqrt{b^2 + d^2}} - C_1 + \frac{b^2}{16R^2} C_2 \right] \text{ cm. . (12)}$$

where

R = mean radius of coil (see Fig. 31);

n = total number of turns;

b = width of strip = axial length of coil;

d = radial depth of coil = outside radius - inside radius;

C_1 and C_2 are constants depending on the shape of the spiral for their values. They are given in Table VI.

TABLE VI
CONSTANTS C_1 AND C_2 FOR EQ. (12)

Ratio $\frac{b}{d}$	C_1	C_2
.00	.500	.125
.05	.549	.127
.10	.592	.133
.15	.631	.142
.20	.665	.155

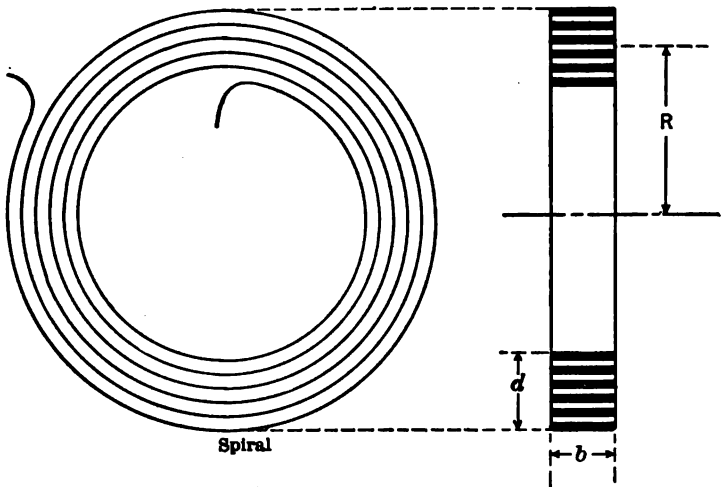

FIG. 31.—Spiral coil of ribbon wound flat wise.

Eq. (12) gives incorrect values if the turns are not close together; the values obtained from the equation must be increased as much as 5 per cent for the spacing used in ordinary transmitting coils in spiral form. Fig. 32 shows how the value of L for a given spiral varies with the number of turns used.

It is interesting to note that the same length of wire will give about the same inductance whether wound into a flat spiral or a single-layer solenoid, provided that the mean radius of the spiral has the same value as the radius of the solenoid.

Toroidal Coil of Rectangular Cross-section. (Fig. 33.)—

$$L = 2n^2l \log \frac{R_2}{R_1} \text{ cm.} \dots \dots \dots (13)$$

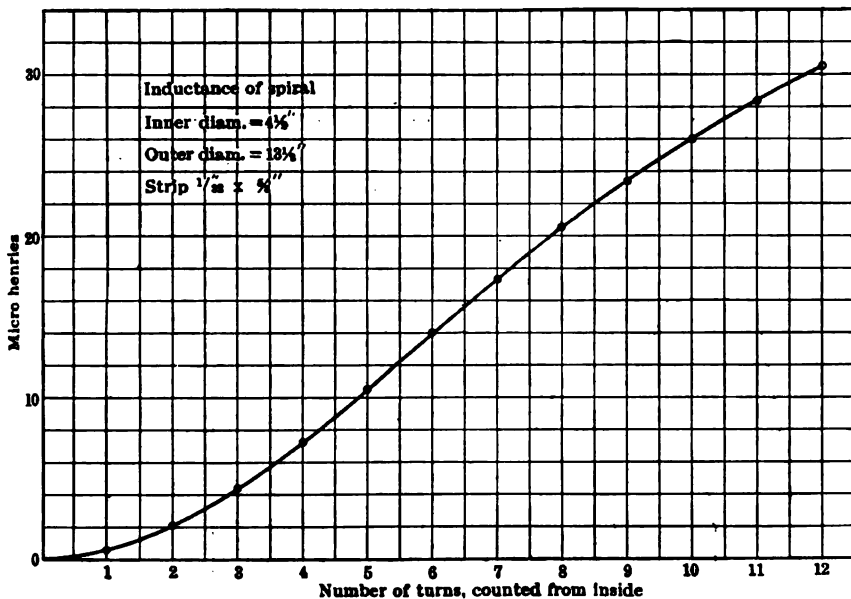

FIG. 32—Inductance of a spiral similar to that shown in Fig. 31.

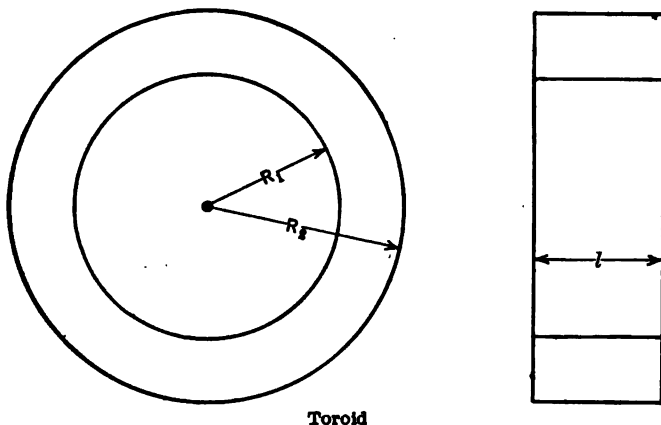

FIG. 33.—Toroidal coil of rectangular cross-section.

where

- n = total number of turns;
- l = axial length of coil;
- R_2 = outer radius;
- R_1 = inner radius.

Toroidal Coil of Circular Cross-section (Torus). (Fig. 34.)—

$$L = 4\pi n^2 (R - \sqrt{R^2 - r^2}) \text{ cm., (14)}$$

where

- n = total number of turns;
- R = mean radius of ring;
- r = radius of cross-section of winding.

The great advantage of a toroidal coil is that it has practically no external magnetic field and so gives but little mutual induction with other circuits. Also a toroidal coil will, for similar reasons, not be affected by mutual induction from other circuits or sources. Used as a tuning coil in a receiving set it will not pick up any strays or other disturbing fields unless they be of excessively short wave length.

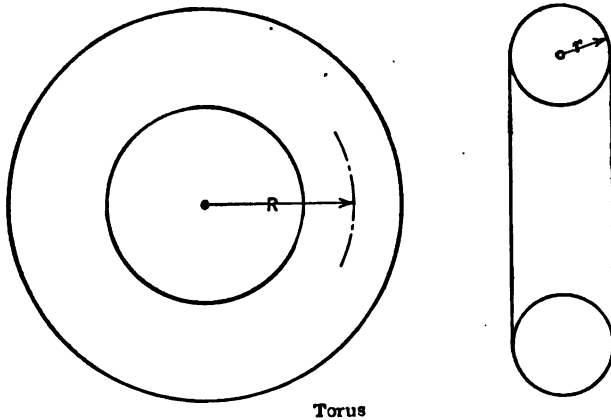

FIG. 34.—Toroidal coil of circular cross-section.

Single Layer Square Coil. (Fig. 35.)—

$$L = 8an^2 \left[\log \frac{a}{b} + .726 + .223 \frac{b}{a} \right] - 8an [A + B] \text{ cm., . . (15)}$$

in which

- a = side of square, measured to center of wire;
- n = number of turns;
- D = pitch of winding, center to center;
- b = axial length of coil = $(n - 1)D$.

A and B are constants depending upon number of turns, pitch, etc., and are given in Tables VII and VIII, d being the diameter of the wire used. Coils wound with rectangular conductor have slightly different constants than those given here.

TABLE VII

$\frac{d}{D}$	A	$\frac{d}{D}$	A
1.00	+ .557	.18	1.16
.90	.452	.16	1.28
.80	.334		
.70	.200	.14	1.41
.60	+ .046	.12	1.56
.50	- .136	.10	1.75
.40	.356	.08	1.97
.35	.443	.06	2.26
.30	.647	.04	2.66
.25	.830	.02	3.36
.20	1.05		

TABLE VIII

Number of Turns, n	B
1	.000
2	.114
3	.166
4	.197
6	.233
8	.253
10	.266
20	.297
40	.315
60	.322
100	.328

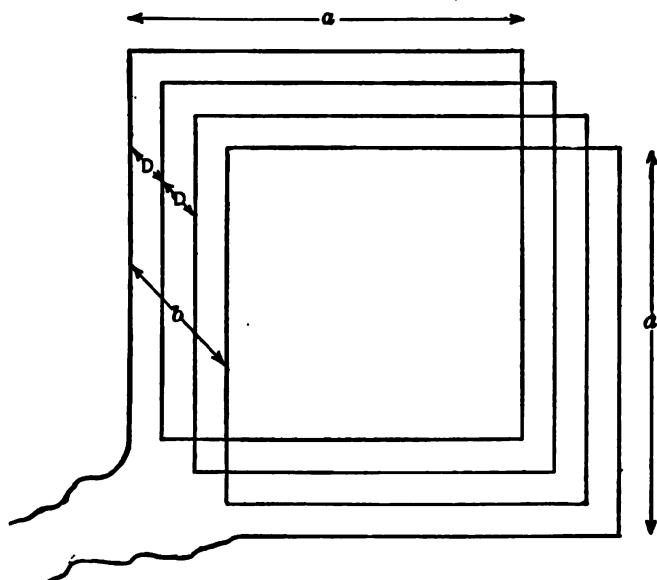

FIG. 35.—Single layer square coil, such as is used for a coil antenna.

Flat Square Coil. (Fig. 36.)—

For this case Eq. (15) is applicable providing a is taken as $a_0 - (n-1)D$

- where a_0 = side of square, outside wire;
- n = number of turns;
- D = distance between turns, center to center.

The value of b is obtained from the depth of the winding, i.e., it is equal to $(n-1)D$.

Multilayer Coils of Rectangular Cross-section.¹ (Fig. 37.)—

$$L = \frac{(2\pi Rn)^2}{b + 1.5t + R} F' F'' \text{ cm.}, \dots \dots \dots (16)$$

where

- R = mean radius of coil in cm.;
- n = total number of turns in coil;
- b = axial length of coil;
- t = radial depth of winding.

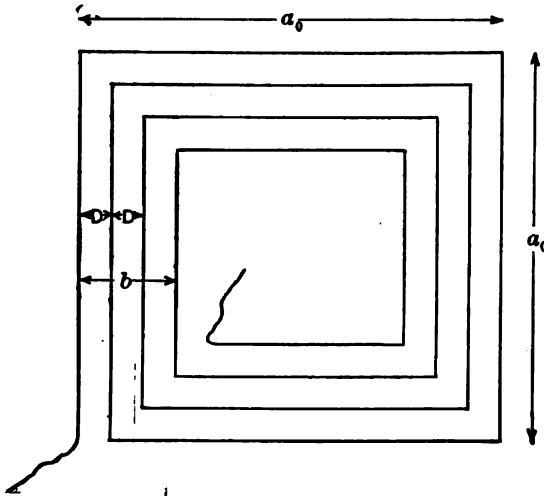

FIG. 36

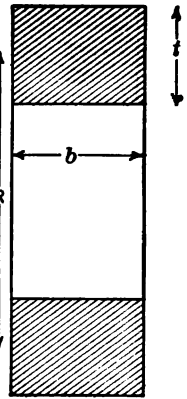

FIG. 37.

FIG. 36.—Flat square coil, used as coil antenna for short wave lengths.

FIG. 37.—Multilayer coil of rectangular cross-section; the cross-hatched area shows the cross-section of the winding.

F' and F'' are correction factors

$$F' = \frac{10b + 13t + 2R}{10b + 10.7t + 1.4R}$$

$$F'' = 1.15 \log_{10} \left(100 + \frac{14R + 7t}{2b + 3t} \right).$$

For accurate results with this formula the distance between wires must be small compared to the diameter of the wire.

A multilayer coil of very ingenious construction is being made at present, using a so-called honeycomb construction. A picture of such a coil

¹ An excellent article on the design of multilayer coils was published in Univ. of California Publications in Engineering Vol. 147, by F. E. Pernot.

is shown in Fig. 38. The coil is self-supporting, in this respect being superior to the multilayer coils described on p. 133 and although its internal capacity is greater than that of the type shown in Fig. 17, it is still sufficiently low to make it an excellent coil for radio circuits, especially those

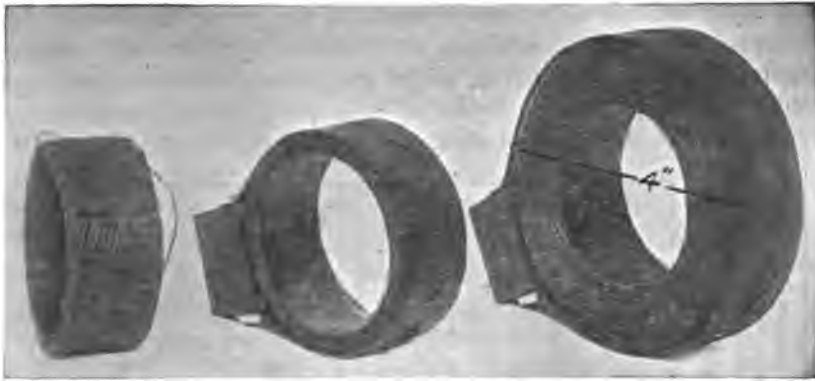

FIG. 38.—“Honey comb” construction of multilayer coil.

calling for many millihenries of inductance. The constants of one of these coils is shown in Table IX.

TABLE IX
CONSTANTS OF A HONEYCOMB COIL

Frequency in 10^2 cycles	R in ohms	L in 10^{-3} henries	Reactance Divided by Resistance
0	9.39		
26.5	12.4	17.75	238
53	23.8	17.85	250
79.5	53.0	18.70	176
106	102.0	20.25	120

The dimensions of this coil were internal diameter=5 cm., external diameter=10 cm., cross-section of winding 2.5 cm. by 2.5 cm.

Variable Inductances.—It is many times desirable to have a continuously variable inductance for tuning a circuit; two such types have been used, one a long solenoid with a sliding contact and the other a pair of coils connected in series, one rotatable inside the other, an inductance of this type being generally styled a variometer.

The solenoid with sliding contact is not good, because the sliding contact frequently lies on two turns at the same time, thus producing a short-circuited turn, decreasing very appreciably the self-induction from

its proper value for the position of the contact, and, due to the current in the short-circuited turn, increasing the effective resistance of the coil. Also there is not much useful variation of inductance obtainable by this method; for long solenoids the value of L increases with the first power of the length only and the coil cannot be used effectively with the contact set to connect in only a small portion of the coil because of the losses occurring in the long unused portion. This part of the coil (generally called a "dead end") is excited like the secondary of a step-up auto transformer; the charging current circulating in the dead end produces losses and so increases the effective resistance of that part of the coil which is

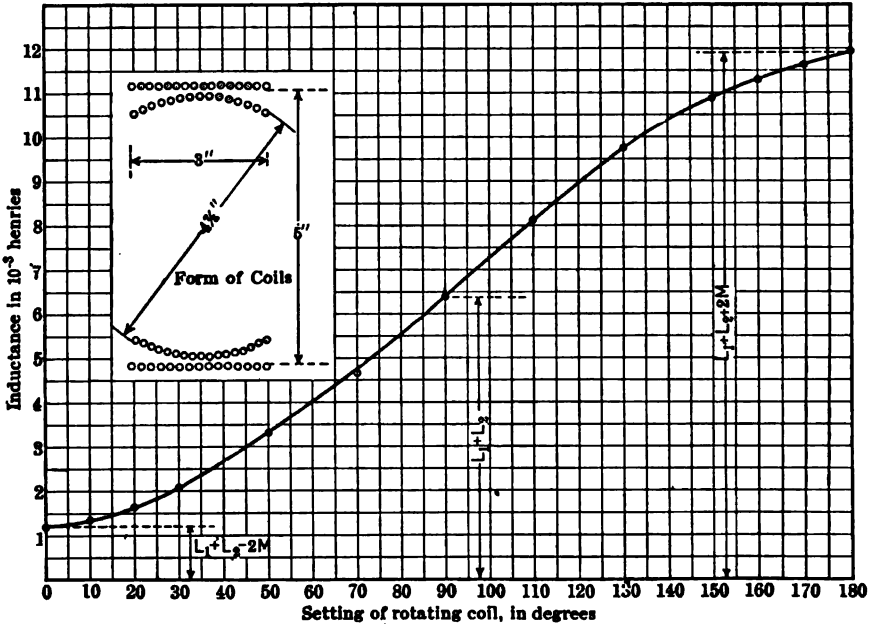

Fig. 39.—Calibration curve of a variable inductance commonly known as a variometer.

used. Long solenoids intended to be used in steps should be divided up into a number of completely insulated sections, these being connected in series as required.

The variometer type of inductance is very convenient and useful, it being continuously variable; the calibration curve of such an inductance is shown in Fig. 39, from which the probable range in inductance can be seen. If the ends of the stationary coil and rotating coil are brought out to separate terminals, the combination forms a very convenient scheme of magnetically coupling two independent circuits, a so-called "coupler."

A rather convenient scheme (even though inefficient) for making a continuously variable inductance out of a short solenoid, is to fix a copper

disk on a shaft inside the solenoid, so that the axis of the disk may be made parallel or not to that of the coil. The eddy currents in the disk, with parallel axes, will very materially reduce the inductance of the solenoid.

The effect of such a solid disk placed inside a short solenoid is given in Table X. The coil was a single layer solenoid 12 cm. in diameter and of 2 cm. axial length; the various disks were 11 cm. diameter and were placed inside the coil, centrally, with the plane of the disk perpendicular to the axis of the coil. It is evident that a copper disk very materially

TABLE X
EFFECT OF METAL DISK INSIDE SOLENOID

Frequency in Kilocycles	Coil alone		1/4-in. Copper Disk		1/4-in. Brass		1/4-in. Brass		1/4-in. Tinned Iron	
	L 10 ⁻³ henry	R ohms	L	R	L	R	L	R	L	R
1	1.060	3.03	.807	3.49	.895	3.77	1.025	3.53	1.055	3.25
5.35	1.052	3.20	.762	4.18	.785	5.13	.870	6.40	.970	6.40
50	1.058	3.35	.751	5.79	.756	8.13	.783	12.6	.865	18.6
149	1.092	5.08	.760	9.17	.765	13.5	.792	17.8	.861	44.3

affects the inductance without prohibitive increase in resistance. By having the plane of the disk rotatable this scheme of varying the inductance of a coil may be useful, e.g., in heterodyne reception, where but slight changes in inductance are desired (to change signal note), and an increase in resistance of the coil is not of serious consequence.

The best adjustable inductance is a multilayer coil, with each layer (or every other one after the first four perhaps) separate from the others, equipped with the proper switch to connect in the circuit as many layers as desired.

Mutual Induction.—The coefficient of mutual induction of two coils may be expressed in terms of energy in the same way as is self-induction. If two coils, so situated with respect to one another that part of the magnetic field of each is linked with the other, are connected electrically in series in such a way that their m.m.f.'s add, the total energy associated with the magnetic field of the circuit is $\frac{1}{2}I^2(L_1 + L_2 + 2M)$ and if the electrical connection is reversed, it is $\frac{1}{2}I^2(L_1 + L_2 - 2M)$. Any change in the circuit which changes that portion of the magnetic energy due to M has

a corresponding effect on the value of M . The value of M may also be considered as fixed by the voltage induced in one coil by current in the other as given in Eq. (6).

The M of the two coils is determined by their relative position; it may be changed, however, even if the relative position of the two coils stays fixed, if a third circuit is brought into the mutual field of the two coils. Thus two equal coaxial coils, placed with their ends close together may have a value of M about .7 as large as L_1 , but if a copper sheet is inserted between the two coils the value of M may be brought nearly to zero.

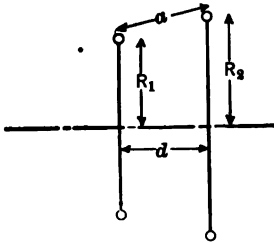

FIG. 40.—Cross-section through two single turns placed coaxially.

The values of M for a few ordinary arrangements are given below, the formulæ being approximations as were those for L ,

the values obtained from the formulæ being accurate to better than 1 per cent in most of the cases.

Two Single Turns, Coaxial. (Fig. 40.)—

$$M = 4\pi\sqrt{R_1R_2} \left\{ \log \frac{8\sqrt{R_1R_2}}{a} \left[1 + \frac{3}{16}\alpha - \frac{15}{1024}\alpha^2 + \frac{35}{128^2}\alpha^3 \dots \right] - \left[2 + \frac{1}{16}\alpha - \frac{31}{2048}\alpha^2 + \frac{247}{6(128)^2}\alpha^3 - \right] \right\} \text{ cm.} \quad (17)$$

$$\alpha = a\sqrt{\frac{1}{R_1R_2}}$$

When the circles have nearly the same radii and the distance between coils is small compared to the radius, the simpler form may be used,

$$M = 4\pi R_1 \left(\log \frac{8R_1}{d} - 2 \right) \text{ cm.,} \quad \dots \dots \dots (18)$$

in which R_1 = radius of smaller circle.

Experimental results showing how M varies for the case shown in Fig. 40 are shown in Fig. 41. The coils used were not actually single turns, but the cross-section of the winding was so small compared with the radius of the coil that they approximated single turns geometrically.

Mutual Induction of Two Coaxial, Circular Coils of Rectangular Cross-section. (Fig. 42.)—An approximate formula for this case (error for most practical cases less than 1 per cent) is

$$M = N_1N_2M_0 \text{ cm.,} \quad \dots \dots \dots (19)$$

where M_0 is the mutual induction between the central turns of the two coils (by Eq. (17)). The curves of Figs. 43 and 44 show the experimentally determined values of M for two typical cases.

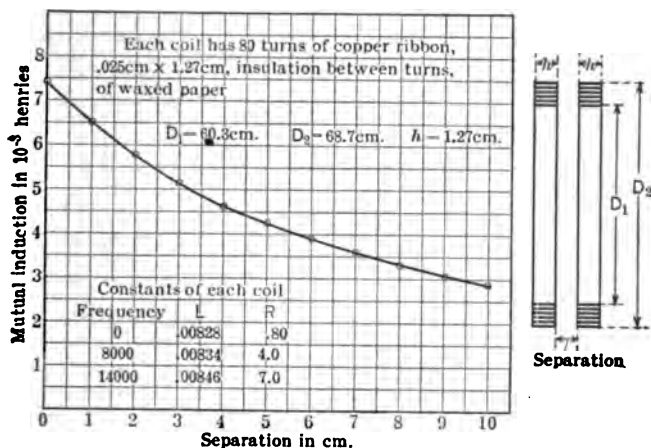

FIG. 41.—Variation in mutual inductance of two coaxial coils with separation; the two coils approximated single turns.

Mutual Induction of Two Coaxial Solenoids.—The formulæ to cover the various cases which may arise in this class are long; the reader is referred to the Bureau of Standards Bulletin No. 74 for discussion of the case. In Fig. 45 are shown, however, three curves for coils of different dimensions; from these curves M for other-shaped coils can be approximated.

Mutual Induction of Two Overhead Parallel Wires, Grounded, at Same Height from Ground.—

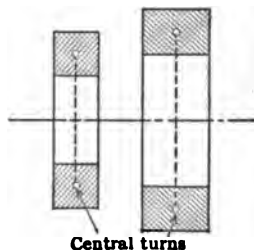

FIG. 42.—Two coaxial multilayer coils.

$$M = l \log \left(\frac{d^2 + 4h^2}{d^2} \right) \text{ cm.,} \quad \dots \dots \dots (20)$$

where

- d = separation of the two wires;
- h = height of wires above ground (same units as d);
- l = length of one wire in cm.

Self-induction of a Two-wire Antenna, Made up of Two Parallel Wires at Same Height from Ground.—

$$L' = \frac{L + M}{2}, \quad \dots \dots \dots (21)$$

- L' = inductance of the antenna;
- L = self-induction of one wire by Eq. (9);
- M = mutual induction of the two wires by Eq. (20).

Mutual Induction between Two Concentric Coils, as One Rotates.
 (Fig. 46.)—This combination of coils is frequently used in radio work, either to make a variable self-inductance or to couple two circuits together.

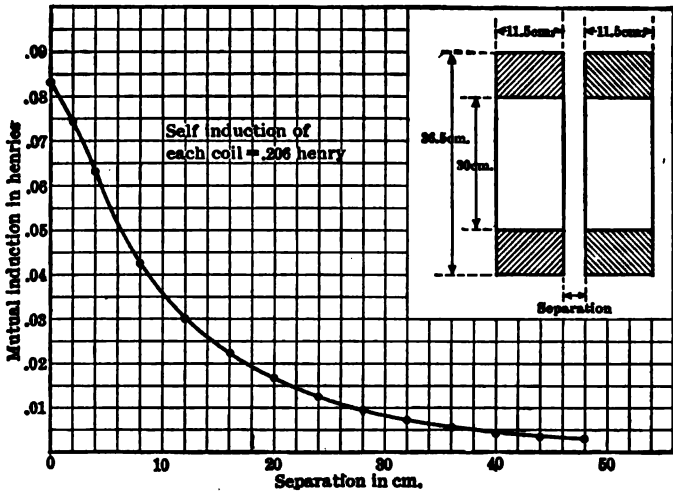

FIG. 43.—Variation of mutual inductance of two multilayer circular, coaxial, coils; separation measured between nearest sides.

The exact expression for M has not been calculated, but an experimentally determined value of M for a certain combination is shown in Fig. 46. In case the two coils are connected in series the self-induction of the com-

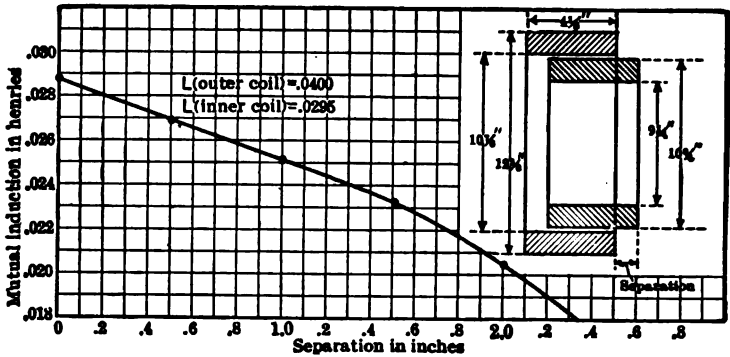

FIG. 44.—Variation in mutual induction of two multilayer circular, coaxial, telescoping coils.

bination is $L_1 + L_2 \pm 2M$. In such variable inductances it is feasible to get a maximum value of L about 12 times as large as the minimum value of L . This range is determined by the manner in which the coils are

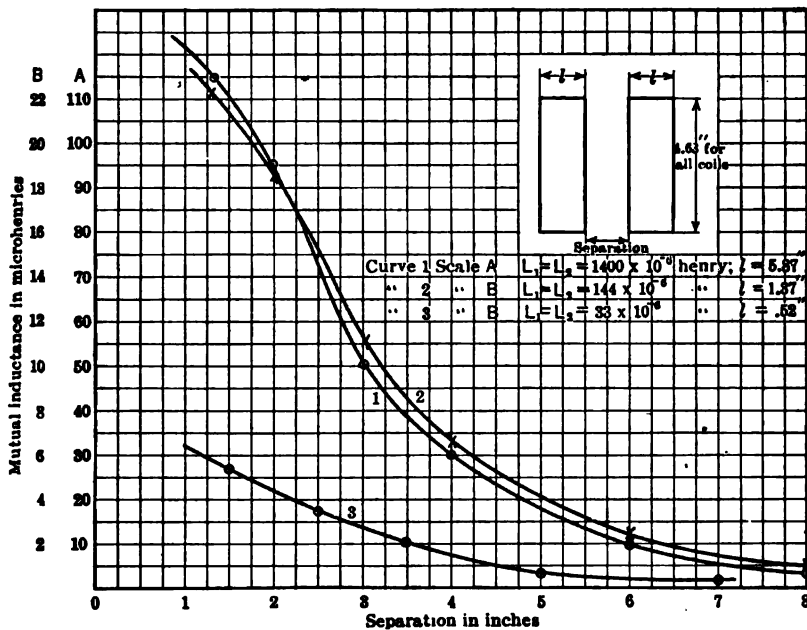

Fig. 45.—Variation in mutual induction of various single layer solenoids placed coaxially.

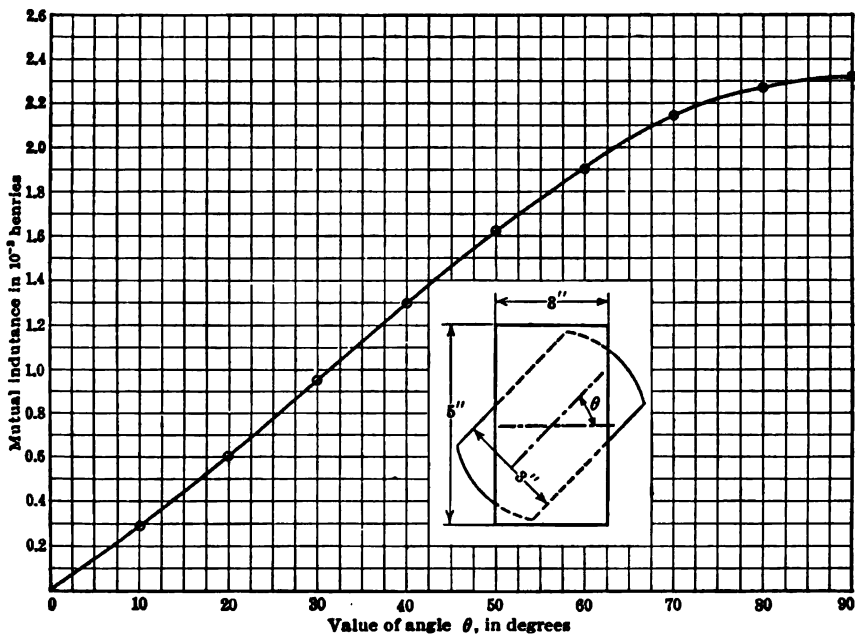

Fig. 46.—Mutual inductance of two coils, one rotating inside the other.

fitted into one another. When both coils are wound in straight cylindrical form (short solenoids) the range in L will not be as great as when both coils are wound on spherical surfaces, making a closer fit possible. A typical calibration of such an inductance is given in Fig. 39, the form of the coils being shown on the curve sheet.

Mutual Induction between Two Coaxial Spirals.—A tedious calculation is necessary to calculate the value of M for two flat spirals arranged coaxially but an idea of what may be expected is indicated in the experimentally determined curves of Fig. 47.

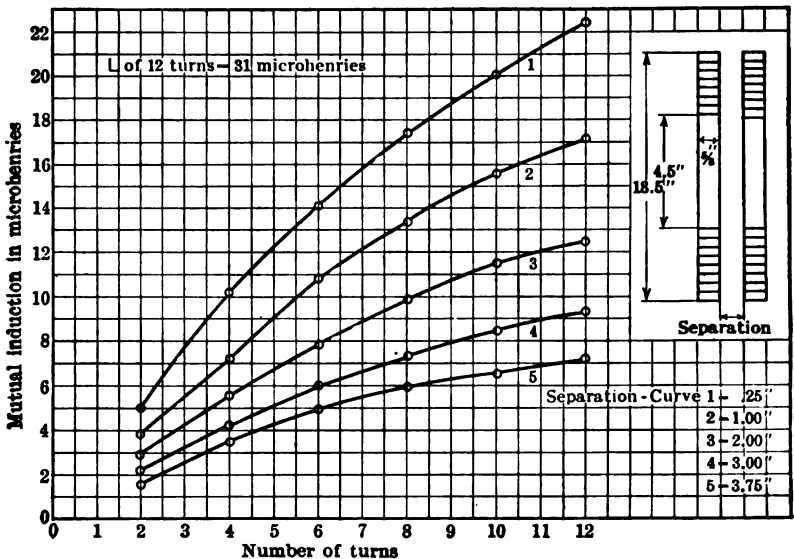

FIG. 47.—Mutual induction of the two flat spiral coils of an oscillation transformer.

Two ribbon-wound spirals of the dimensions given on the curve sheet were used; the number of turns in one spiral was fixed at 12, while the sliding contact on the other was used to vary its number of turns as indicated on the curve sheet—the value of M was measured for various separations of the two spirals. The results shown in Fig. 41 indicate the higher values of M obtainable when the radial depth of the winding of the spiral is smaller.

CAPACITY

General Idea of Capacity.—The electrostatic capacity of a body may be thought of either in terms of the quantity of electricity stored for a given potential difference between the two surfaces constituting the condenser or in terms of the energy in the electrostatic field, the value of this capacity, in farads, being equal to twice the energy of the field, measured in joules, when the potential difference is one volt.

There may be still another idea of capacity when looking at a circuit from the standpoint of electrical reactions, just as there is for inductance and resistance. When a current flows in a circuit the circuit will generate counter forces called reacting forces or reactions. If the current flowing is one ampere the amount of reacting force set up in phase opposition to the current, in volts, is the resistance of the circuit in ohms—the reacting force set up in phase with the current is the negative resistance of the circuit, the reacting force set up 90° behind the current is the inductance reaction in volts, and the reacting force set up 90° ahead of the current is the capacity reaction. The capacity and inductance are calculated from their respective reactions, $\frac{1}{2\pi fC}$ and $2\pi fL$, f being known. The reactions may be caused by ordinary coils, condensers, and wires, but it must be remembered that in special cases a circuit may give capacity reaction when there are no condensers, and it may give inductance reaction when there are no coils present. Thus an overexcited synchronous motor is electrically equivalent to a condenser; a tuned electrostatic telephone when excited at certain frequencies develops (due to its motion) an inductance reaction and there are no coils used in the telephone.

It must also be remembered that the capacity of a body in general changes with the frequency. Not only does the viscous action of the dielectric decrease the effective specific inductive capacity constant as the frequency is increased, but in many circuits, the capacity of which is under consideration, the potential distribution changes with frequency, and as the electrostatic energy (hence capacity) depends upon the potential distribution, the capacity may be expected to change with frequency.

The formulæ given herewith are good only for stationary charges; if the circuit considered is electrically long, the values obtained from these formulæ are not correct except at very low frequencies. The capacity calculated from these formulæ is in centimeters; to change to micro-micro-farads ($\mu\mu f$) the values obtained must be divided by 0.9 and to get milli-micro-farads the values must be divided by 900. Where the abbreviation \log is used the natural logarithm (to base e) is intended.

Capacity of a Conducting, Isolated, Sphere in Air.—

$$C = r \text{ cm.}, \quad \dots \dots \dots (22)$$

where

 r = radius of sphere in cm.**Capacity of Two Flat, Circular Parallel Plates in Air.—**

$$C = \frac{r^2}{4d} \left\{ 1 + \frac{d}{\pi r} \left(\log \frac{16\pi(d+t)}{d^2} + \frac{t}{d} \log \frac{d+t}{t} + 1 \right) \right\} \text{ cm.}, \quad \dots (23)$$

 r = radius of plates in cm.; t = thickness of plates in cm.; d = separation of plates in cm.**Capacity of Two Flat Plates (approximate Formula).—**

$$C = \frac{KA}{4\pi d} \text{ cm.}, \quad \dots \dots \dots (24)$$

 K = specific inductive capacity of dielectric; A = area of one side of one plate in sq. cm.; d = separation of plates in cm.**Single Vertical Wire, Proximity to Earth Neglected.—**

$$C = \frac{l}{2 \log \frac{l}{r}} \text{ cm.}, \quad \dots \dots \dots (25)$$

 l = length in cm.; r = radius in cm.

In several experiments with the lower end of the wire close to the earth, the measured capacity exceeded that calculated from the formula by about 10 per cent.

Single Horizontal Wire, Earth for Other Plate.—

$$C = \frac{l}{2 \log \frac{2h}{r}} \text{ cm.}, \quad \dots \dots \dots (26)$$

 l = length of wire in cm.; h = height of wire above earth; r = radius of wire, same units as used for h .

This formula assumes the charge in the wire distributes itself uniformly over the periphery. Actually the lower side of the wire has a slightly

greater density of charge than the upper side, resulting in a formula in hyperbolic functions.

$$C = \frac{l}{2 \cosh^{-1} \frac{h}{r}} \text{ cm.} \dots \dots \dots (27)$$

When $h/r=5$ Formula (27) gives a result 15 per cent greater than does (26). For greater values of h/r the discrepancy between the two is less. In general whenever two wires are so close together that the separation is not more than 5 times their diameter, hyperbolic functions are required for precise results, rather than the ordinary logarithmic formulæ, for either the inductance or capacity. In practice the ratio of h/r is much greater than 5 except for one or two cases, such as the wires of a telephone cable, etc.

Mutual Capacity of Two Horizontal Wires, Such as Two Wires of an Antenna.—

$$C = l \frac{\log \sqrt{\frac{d^2 + 4h^2}{d^2}}}{2 \left[\left(\log \frac{2h}{r} \right)^2 - \left(\log \frac{d^2 + 4h^2}{d^2} \right)^2 \right]} \text{ cm.,} \dots \dots (28)$$

- where l = length of one wire;
- h = height of each wire;
- r = radius of wire;
- d = distance between wires.

The mutual capacity is not the same as the capacity of the two wires regarded as the two plates of a condenser, one charged positively while the other is charged negatively. It really represents a decrease in the capacity of one of the wires with respect to earth caused by the presence of the field of the other.

In Fig. 48 this point is illustrated; the normal field of wire a to earth is shown by the full lines and that of wire b is shown by dotted lines, and it is evident that the two fields overlap.

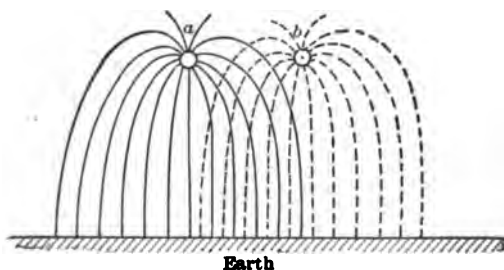

FIG. 48.—Diagram illustrating the “overlapping” of the electric fields of two antenna wires.

The total capacity of these two wires, to earth, is diminished to some extent by this overlapping of the two individual fields, and a measure of the decrease in capacity is given by the value of M from Eq. (28).

Capacity of Two Horizontal Overhead Wires with Respect to Each Other.—This is the case of using the two wires of Fig. 48, one as one side of a condenser and the other one for the other side of the condenser.

$$C = \frac{l}{4 \log \frac{d}{r}} \text{ cm, (29)}$$

where l = length of one wire in cm.;
 d = separation of the two wires;
 r = radius of the wire in same unit as d .

This formula supposes the distance between the wires is small compared to the height above the earth; for wires close to the earth, compared to their separation, this formula gives values of C too low.

Capacity of Two-wire Antenna.—This is the case of the two wires of Fig. 48 being connected together and their capacity with respect to earth being determined. It is equal to twice the capacity of one wire with respect to ground (Eq. (26)) diminished by the mutual capacity of the two wires (Eq. (28)).

In case the two wires are far apart the value of capacity is twice that of one wire, and as the wires approach each other the capacity decreases, until when the two wires touch, their combined capacity is not greatly in excess of that of a single wire.

It is interesting to note that the self-induction of a pair of wires (the two wires of an antenna, for example) increases as the wires approach, whereas the capacity of the pair diminishes. In fact the variation is nearly reciprocal, so that the product of L and C of the pair is independent of the spacing of the two wires.

The foregoing formulæ for capacity of wires with respect to earth are not very accurate, not being corrected for end effects, etc. It does not seem worth while to use more elaborate formulæ, however, because the presence of foreign bodies in the electrostatic fields of antennæ, such as trees, masts, stays, etc., influences the value of capacity to a large extent. Also the height of a wire is ambiguous; this height is really to be measured to conducting earth (wet) and the height of the wires above wet earth may not be easy to determine.

Recently Austin¹ has given an empirical formula for the capacity of an antenna, the formula apparently being fairly accurate (say within 10 per cent) for any ordinary form of antenna. It is

$$C = \left(36\sqrt{A} + 7.97 \frac{A}{h} \right) \text{ cm. (29a)}$$

A = area of the antenna in sq. meters;
 h = mean height of the antenna, in meters.

¹Louis W. Austin, Calculation of antenna capacity, Proc. I. R. E., Vol. 8, No. 2.

In case the length of the antenna is more than eight times the breadth a slight additional correction is necessary, this increase being equal to $\frac{\text{length}}{\text{breadth}} \times 1.5$. per cent.

In calculating *A*, the length of the antenna is multiplied by its breadth, the area thus obtained being of course much greater than the actual surface of the antenna wires. With the ordinary antenna a spacing of one meter between wires will give a capacity about 90 per cent of that which would be obtained if sufficient wires were used to completely fill the space occupied by the antenna, so that neighboring wires touched each other.

Capacity of a Multiplate Condenser.—

$$C = \frac{KA(n-1)}{4\pi d} \text{ cm. (30)}$$

A = area of one side of one plate in sq. cm.;

n = total number of plates;

d = separation of plates in cm.;

K = specific inductive capacity of dielectric.

Various Forms of Variable Condenser.—It is in general more convenient to make a condenser continuously variable than to make an inductance of that kind, hence the tuning of a radio circuit is generally accomplished by using fixed steps of inductances and a continuously variable condenser. These variable condensers are made with either sliding plates, one set of plates moving in groves in insulating blocks, or with rotating plates, one set of plates being mounted on a shaft.

If the sliding plates are rectangular (and move parallel to one side) or the rotating plates are circular (with shaft on which they rotate in the center), then the amount of capacity in the condenser will vary directly with the amount of movement (sliding or rotation) of the moving plates and the calibration curve will be a straight line. This straight line will not pass through the zero-zero point, because even with zero scale setting there is still an appreciable capacity in the condenser.

It is many times convenient to have the capacity vary with the setting to some other power than the first; thus if it is used in a wave meter (see Chapter X) it is convenient to have the capacity vary as the square of the setting and the wave length scale will then be a straight line. For other purposes it is convenient to have a logarithmically varying capacity so that a scale division everywhere represents the same percentage change in capacity. Both of these variations of capacity are obtainable in rotating plate condensers by properly shaping the rotating plates and suitably placing the shaft in which they turn.

Two typical calibration curves are shown in Fig. 49, for semicircular plates with central shaft, and for specially formed plates, with displaced shaft. In the first the capacity varies directly as the angle of the movable plates and in the second the scale reading is proportional to the logarithm of the capacity.

Losses Occurring in Condensers.—When a condenser is used in a high-frequency circuit there are various losses which occur, all of which are detrimental and to be avoided if possible. The losses may be due to actual leakage from one plate to the other through or around the dielec-

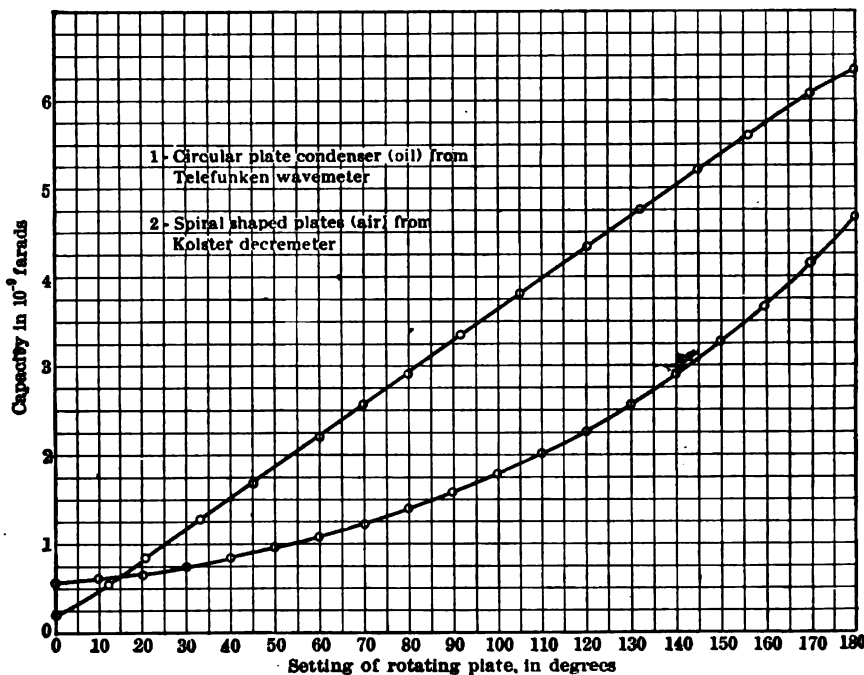

FIG. 49.—Calibration curves of typical condensers used in radio apparatus.

tric, to dielectric hysteresis, to I^2R loss in the conducting plates of the condensers, and due to corona losses from the edges of the plates. When a condenser is used in a receiving circuit (low voltage) only the first three sources of loss exist.

For an air condenser constructed with rugged plates of negligible resistance all of the losses in the condenser properly are negligible except at voltages high enough to give corona loss. However, the supports, terminals, etc., of the air condenser must be mounted on very good insulators, otherwise an appreciable resistance may be incurred due to the dielectric hysteresis and leakage at these points. Quartz or high-grade porcelain should be used at these points.

Condensers using glass, paper, rubber, or mica for the dielectric have some dielectric losses, although this loss in a well-constructed mica condenser (air and moisture excluded) seems to be very small; the dielectric losses in paper and some grades of glass are high. Dry oil is in general a very good dielectric with very low losses; the oil has an added advantage over a solid dielectric, in that a disruptive breakdown does not spoil the condenser, the oil repairing itself with no deleterious effects unless sufficient arcing occurs in the oil to produce considerable carbonization. A good grade of mineral oil is generally used, but the author has found castor oil to be excellent, having a high dielectric strength, low losses, and having such a high specific inductive capacity as to give about twice as much capacity as the same amount of mineral oil. The value of *K* for various dielectrics is shown in Table XI.

TABLE XI

SPECIFIC INDUCTIVE CAPACITY OF MATERIALS USED MORE GENERALLY IN RADIO CONDENSERS (MEASUREMENTS AT LOW FREQUENCY)

Material	Value of <i>K</i>	Material	Value of <i>K</i>
Ebonite.....	2.5-3.5	Porcelain.....	4.38
Ebonite.....	1.9 at about 4×10^7 cycles.	Quartz.....	4.50
Glass, density:		Resin.....	2.50
2.5-4.5.....	5-10	Shellac.....	3.0-3.7
Glass, density:		Castor oil.....	4.7
2.5-4.5.....	2.7 at about 5×10^7 cycles.	Olive oil.....	3.1
Gutta percha...	3.3-4.9	Petroleum oil...	2.1
Mica.....	4.6-8.0	Vaseline.....	2.2
Paraffin wax....	2.0-2.5		

Formica, bakelite, bakelite-dilecto, and such compounds have a value of *K* of about 5, generally lying between 5 and 6.

It must be remembered when using solid dielectric condensers that practically all such materials as glass, rubber, paper, wax, etc., very rapidly lose their insulating properties as the temperature increases. In fact the operation of most solid dielectric condensers becomes unstable above a certain voltage; above this critical voltage the condenser will soon break down if left connected to the circuit. This is due to the cumulative effect of the losses in causing temperature rise, the higher the temperature the higher the losses become, thus again increasing the temperature. Some special paper condensers passed a puncture test of 4000 volts successfully, but upon being connected to a 2000 volts 60-cycle line every one out of the twelve tested broke down in less than twenty minutes. The same experience was had to an even more marked degree with a lot of mica condensers.

It must also be remembered that a condenser passing a voltage test successfully when tested in a 60-cycle line may break down after a few minutes' operation on a high-frequency circuit with a voltage only a small fraction of the 60-cycle voltage which it withstood successfully. In certain parts of a vacuum tube the glass (as dielectric) is subjected to high-potential gradients at high frequency and it shows losses many times as great as might be expected from low-frequency tests.

Even quartz, which is one of the best dielectrics, shows this effect; a certain piece required 46,000 volts to puncture when the voltage was continuous, whereas it broke down at 18,000 volts (effective) after being connected to a 500-cycle line for a few minutes.

Equivalent Series or Shunt Resistance of a Condenser.—All of the losses in a condenser can be grouped together and represented by a certain hypothetical series resistance; the value of this resistance will, in general, be different for different frequencies. Thus in Fig. 50 let a represent a

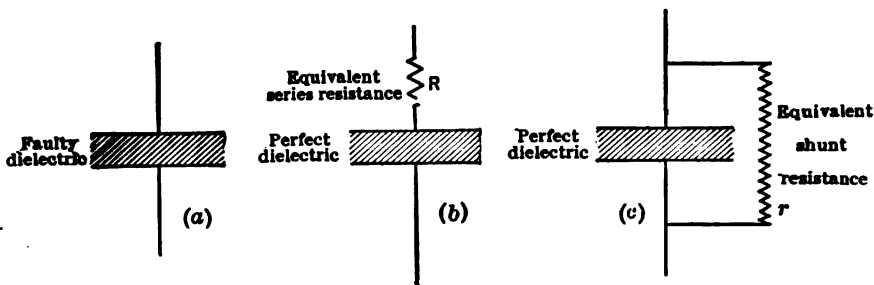

FIG. 50.—A condenser with imperfect dielectric may be represented by one having perfect dielectric in series with, or shunted by, a suitable resistance.

condenser which is drawing a current of 2 amperes at a certain frequency, and has a total power loss due to all causes of 7.5 watts. Then this faulty condenser can be well enough represented by a perfect condenser b (of the same capacity as a) having no losses, but having in series with itself a non-inductive resistance R , such that the charging current of condenser b , flowing through this resistance, will dissipate the same amount of power as is lost in the faulty condenser a . For the case cited above we

shall have $R = \frac{7.5}{2^2} = 1.88$ ohms. The faulty condenser might also be

replaced by a perfect condenser and a suitable leak, or shunt, resistance. If the voltage in the condenser is E , the loss in a shunt resistance is E^2/r , so in c , Fig. 50, is shown this arrangement and for the case cited, if the voltage is 5000 volts the proper shunt resistance is obtained by putting

$$\frac{5000^2}{r} = 7.5 \text{ or } r = \frac{5000^2}{7.5} = 3.34 \times 10^6 \text{ ohms.}$$

These simple calculations hold only for condenser of low power factor, say 0.02 or less, but as all good radio condensers have a lower power factor than this the method outlined above is accurate enough. The relation between the equivalent series resistance and equivalent shunt resistance is obtained from the relations (which, it must be remembered, hold good for low power factor condensers only)

$$I^2 R = \omega^2 C^2 E^2 R = \frac{E^2}{r},$$

or

$$r = \frac{1}{\omega^2 C^2 R}, \dots \dots \dots (31)$$

R being the series resistance and *r* the shunt resistance.

For most dielectrics the equivalent series resistance varies inversely with the frequency, indicating a constant energy loss per cycle.

Characteristics of Ordinary Power Condensers.—Tests made by L. W. Austin on various condensers used for the transmitting circuits of radio sets gave results as shown in Table XII. The tests were made at 14,500 volts and 300,000 cycles with damped wave excitation of 120 sparks per second.

TABLE XII

Kind of Condenser	Power Factor	Capacity in 10 ⁻⁹ farads	Equivalent series resistance in ohms
Compressed air001	5.8	.14
Leyden jar in oil (glass)003	6.0	.28
Composition Murdoch004	5.4	.41
Glass plates in oil005	4.2	.58
Moscicki condenser006	5.5	.57
Leyden jar in air016	6.1	1.4
Molded micanite023	4.1	2.9
Paper024	5.8	2.2

In the case of the compressed-air condenser it is probable that practically all of the loss was attributable to dielectric losses in the insulated lead-in wire. At the voltages used it seems that the ordinary Leyden jar used in radio sets has considerable corona or leakage loss, because immersion in oil cut the losses to about 20 per cent of the value in air. Mica condensers were not tested at this time, but recent tests give them an efficiency rating nearly equal to the compressed air.

Test made by E. F. W. Alexanderson, using a high-frequency alternator for source of power, shows power factors greatly in excess of the values given by Austin's results. Some of the values obtained by Alexanderson are given in the accompanying table; the frequency used varied from

20 kilocycles to 90 kilocycles, and the potential gradient from 5000 volts per cm. to 20,000 volts per cm. The power factor for most of the dielectrics tested increased somewhat with frequency increase, the amount of increase begin small for the better dielectrics; thus the power factor for mica was constant within the range of frequency used, while glass increased from .013 to .016. All of the samples showed an increase of power factor with increased potential gradients, a slow increase at first, then more rapidly until rupture occurred; glass, e.g., increased its power factor from .013 to .015 with a change in potential gradient from 5000 to 12,000 volts per cm., and when the gradient was further increased to 19,000 volts per cm. the power factor rose to .054.

For a gradient of 10,000 volts per cm. and frequency of 50,000 cycles the results obtained were as follows:

Material	Power Factor	Watts loss per cm. cube
Built-up mica019	.15
Glass014	.25
Paper021	.26
Varnished cambric031	.35

The mica used was built up from small mica sheets and some binding cement; it seems likely that the losses in the cement and possible small air cavities caused more loss than did the mica itself; the small temperature rise in a good mica condenser built especially for radio work would indicate that a comparatively small part of the loss found by Alexanderson was due to losses in the mica itself, unless a poor grade had been used. He found some samples of built-up mica with a power factor as high as .07; it would seem likely that a lot of air was trapped in this sample. Some recent tests have indicated a power factor in mica as low as .0003.

It will be noticed that there is a considerable difference between Austin's results and those of Alexanderson; e.g., glass gave power factors of .005 and .014, in the different measurements. The difference is probably attributable to the different quality of glass used and also to the fact that different methods of experimentation were used; in one case the material was subjected to the loss continuously and in the other for only a small fraction of the time. Alexanderson used continuous wave excitation and Austen a 120-cycle spark; the resulting temperature rise was undoubtedly different in the two tests.

Most of the solid dielectrics using bakelite for base have a power factor (at radio frequencies) of about 4 per cent. Some show a power factor, increasing with age of the material, the power factor of some of them increases with increase in frequency and in others a decrease of power factor occurs.

Phase Difference of a Condenser.—In a good condenser the angle of current lead, ϕ , is very nearly 90° ; the power factor of the condenser is the cosine of this angle, ϕ , or it may be put equal to $\sin \psi$, where $\psi = 90^\circ - \phi$. This angle ψ is called the phase difference of the condenser, and it is evident that if ψ is only 1° or 2° that the power factor of the condenser, $\cos \phi = \sin \psi = \psi$, hence, the power used in a condenser is readily given in terms of ψ .

Power used

$$= EI \cos \phi = EI\psi = \omega CE^2\psi. \dots \dots (32)$$

The power factor of the condenser

$$= \frac{\text{Resistance}}{\text{Reactance}} = R\omega C. \dots \dots (33)$$

The phase difference of a condenser to be used for radio work should never exceed 2° ; a greater value indicates excessive dielectric loss.

Phase Difference Caused by Dielectric loss is Constant for a Given Material.—The dielectric loss in most dielectrics varies with the square of the potential gradient in the dielectric, other quantities being fixed; this merely states the fact that the power factor of the condenser is independent of the voltage. Such has been found to be true for most materials, for voltages well below the rupturing strength of the dielectric. If then we have a condenser (of certain capacity), made with a certain dielectric, it will produce a certain loss, no matter how much or how little of the dielectric we use. Thus if we double the thickness of the dielectric (cutting the gradient in half) we must increase the area of the dielectric by two, thus using four times the volume of the dielectric as before. With the gradient cut in two the dielectric loss per unit volume is cut to one-fourth, but as we have four times the volume the total loss is the same.

It seems then that the efficiency of a condenser cannot be improved by using more or less dielectric; a better dielectric must be substituted if the phase difference, ψ , is to be reduced. Fig. 51 serves well to illustrate this point, the curves showing the experimentally determined resistance and capacity of a variable condenser having ebonite for the dielectric. The condenser showed the product $RC = 14 \times 10^{-9}$ everywhere throughout the scale; the test was performed at 25,000 cycles, giving a value for $\psi = .0022$. In this condenser, therefore, the current leads the voltage by an angle of 89.874° .

Internal Capacity of a Two-layer Solenoid.—A certain single-layer solenoid had an inductance of 1000 $\mu\mu h$ at 600 meters; another solenoid was at hand which had the same dimensions as the first, but it had two layers of wire instead of one, giving it twice as many turns. Tested at 1000 cycles it showed an inductance slightly more than four times as great as the single-

layer solenoid, as it should, but when tested at 500,000 cycles it acted like a condenser, not like an inductance; in fact it ceased to act like an inductance for frequencies above 200,000 cycles. This peculiar behavior was caused by the internal capacity of the coil; this internal capacity may be represented to a certain degree of approximation, as a condenser connected in parallel with the terminals of the coil. It is then evident that above a certain frequency the current taken to charge the condenser

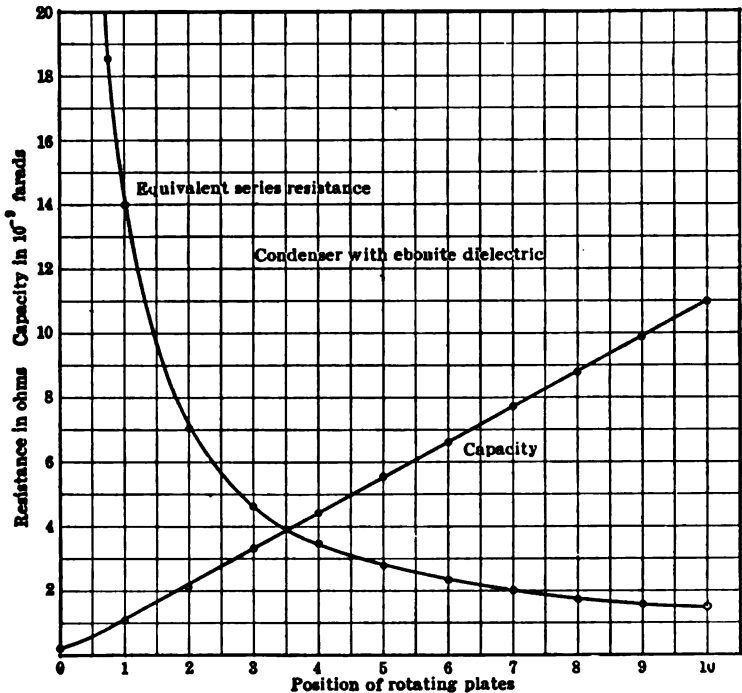

FIG. 51.—Variation of equivalent series resistance of a radio condenser having ebonite dielectric.

will be greater than the current through the coil itself, making the combination circuit act like a condenser, of capacity varying with the frequency.

The calculation of the internal capacity of a coil is most conveniently carried out by calculating the electrostatic energy stored in the coil for a given voltage; the value of C is then at once obtained. The capacity of the two-layer solenoid referred to above will first be calculated. Fig. 52 depicts the arrangement of the electrostatic and magnetic fields of the coil when current is flowing through it; when the impressed e.m.f. is continuous, the difference in potential between the two layers varies directly as the distance from the end where the two layers connect together,

being zero at this point. When the impressed e.m.f. is alternating, this potential difference between the two layers is no longer a straight line variation but varies more rapidly in the center of the coil; the exact form of this potential difference curve varies with the frequency and with the shape of the coil.

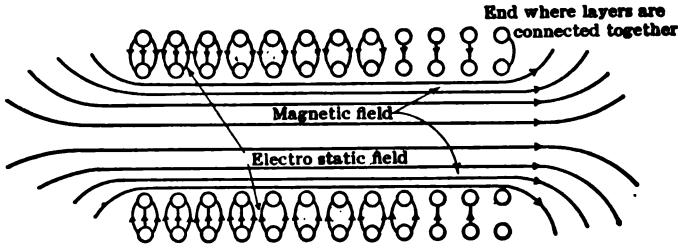

FIG. 52.—Magnetic and electric fields in an ordinary two-layer solenoid.

It is noticed that the capacity of the coil is essentially that of two concentric cylinders, the separation of these two cylinders being determined by the average separation of the wire on the two layers of the coil, being perhaps four times the thickness of insulation of the wire, for wire and insulation with relative proportions as shown in Fig. 53; this is about the right scale for No. 24 double cotton-covered wire. With such wire

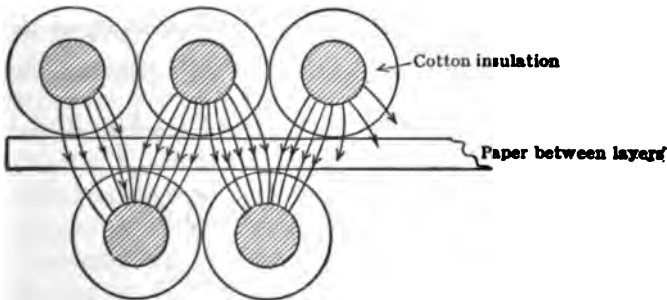

FIG. 53.—Electric field between neighboring conductors of a two layer solenoid.

then we can calculate the capacity by replacing the actual coil by two conducting cylinders having the same diameter and length as the coil, and separated by a distance equal to four times the thickness of insulations of the wire. As the separation of the cylinders is so small compared to the diameter, the capacity may be calculated by using the formula for flat plates. Hence we get

$$C = \frac{2\pi r l K}{4\pi 4t} = \frac{r l K}{8t} \text{ cm.} \dots \dots \dots (34)$$

where r = mean radius of coil in cm.;
 l = length of coil in cm.;
 t = thickness of insulation in cm.;
 K = specific inductive capacity of dielectric.
 If the coil is impregnated with shellac,
 $K = 3$.

Eq. (34) gives the capacity for static charges, the two cylinders being insulated from one another; in the coil, however, the two cylindrical surfaces are actually connected together at one end. The problem then resolves itself in one of determining the equivalent capacity of two cylinders having a potential difference of zero at one end and E volts at

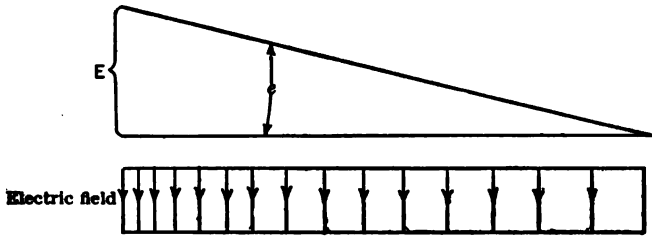

FIG. 54.—Variation in potential difference between the layers of a two layer solenoid, at low frequency.

the other. The diagram in Fig. 54 gives the elements of the problem; two plates, capacity per unit length = $\frac{rK}{8t}$ with potential difference as represented by the e curve in the upper part of Fig. 54. The energy stored in an element of length of the condenser is,

$$dW = \frac{rK}{8t} \frac{e^2}{2} dx = \frac{rKE^2}{16t} \left(1 - \frac{x}{l}\right)^2 dx.$$

The total work stored in the electrostatic field,

$$W = \frac{rKE^2}{16t} \int_0^l \left(1 - \frac{x}{l}\right)^2 dx = \frac{rKE^2}{16t} \frac{l}{3}.$$

Now we define capacity in a problem like this by putting the total energy stored in the field equal to $\frac{C'E^2}{2}$ where C' is the capacity we desire to calculate.

$$\text{So } \frac{C'E^2}{2} = \frac{rKE^2l}{48t} \text{ or } C' = \frac{rKl}{24t}. \dots \dots \dots (35)$$

By comparison with Eq. (34) we see that the equivalent capacity of such a coil, assuming uniform change in the potential gradient from one

end to the other, is equal to one-third of the static capacity of the two surfaces.

The actual distribution of potential differences between the two layers is more nearly as shown in the curve of Fig. 55; such a distribution will result in C' being somewhat smaller than the value obtained in Eq. (35).

Internal Capacity of a Multiple-layer Coil.—A multilayer coil constructed with an air space between each layer may have a comparatively small internal capacity in spite of the fact that it has 10 or 20 layers of winding; a short analysis shows that the internal capacity, as a matter of fact, decreases with an increase in the number of layers. If the capacity

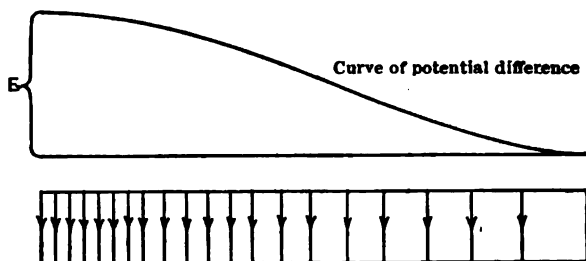

FIG. 55.—Potential difference between the two layers of a two layer solenoid at high frequencies.

between two adjacent layers of the coil is C then the internal capacity of a coil having N layers is nearly C/N , as will be shown.

The electrostatic field in such a coil has a distribution about as shown in Fig. 56, which represents a cross-section through the winding of an air-spaced coil, having 8 layers. The cross-section is shown through one side of the coil only, the other side of the coil would be similar.

If a voltage of E volts is impressed across the terminals of the coil, the voltage between adjacent layers (at the ends where the two layers are not connected) is $E \div N/2$.

Let the normal geometrical capacity between two adjacent layers be C , this is the capacity between two cylinders, insulated from one another, of same dimensions as the layers of wire, and spaced by the space between the two layers of wire. If the potential gradient between two adjacent layers is assumed to vary uniformly from a maximum at one end to zero at the other (where the two layers connect together) as illustrated in Fig. 54 the energy between two adjacent layers is found by integration to be

$C \frac{2E^2}{3N^2}$. As there are $N-1$ spaces between layers where this much energy

is stored the total energy stored is $(N-1) \frac{2E^2C}{3N^2}$.

Now if we consider a condenser made up of two cylinders having the same dimensions and spacing as the inner and outer layers of the coil, its capacity would be equal to $\frac{C}{N-1}$, the thickness of dielectric being $(N-1)$

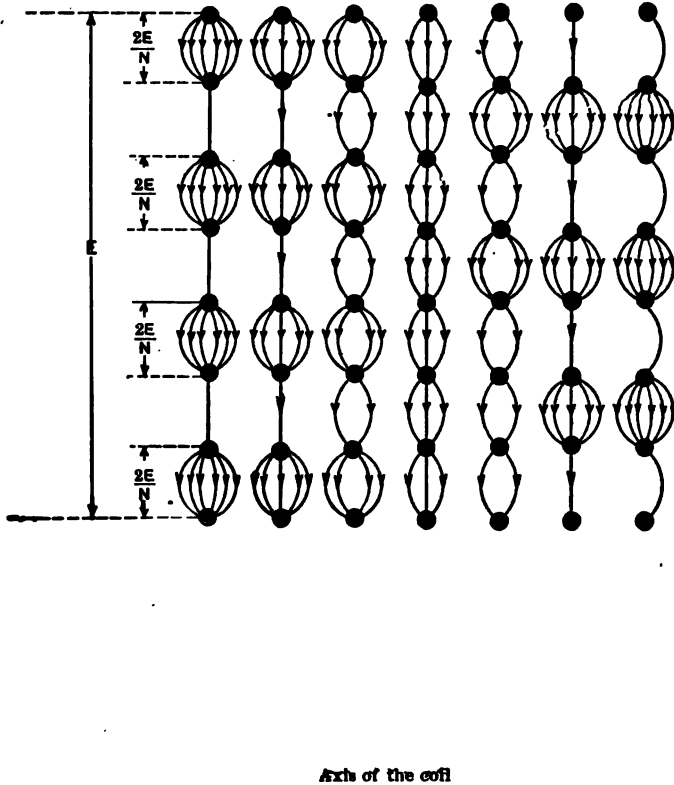

FIG. 56.—Electric field distribution in a multilayer coil.

times as thick between the innermost and outermost layers as it is between two adjacent layers. The stored energy in such a condenser would be

$$\left(\frac{C}{N-1}\right)\frac{E^2}{2}.$$

But from the previous paragraph the stored energy in the coil is actually

$$(N-1)\frac{2E^2C}{3N^2} = \left(\frac{N-1}{N}\right)^2 \frac{2E^2}{3} \left(\frac{C}{N-1}\right),$$

from which it follows that the equivalent internal capacity of a multilayer coil is equal to $\frac{4}{3} \left(\frac{N-1}{N} \right)^2 \times$ the capacity between the inner and outer layers, that is

$$C' = C_0 \times \frac{4}{3} \left(\frac{N-1}{N} \right)^2 \dots \dots \dots (36)$$

where C_0 = capacity from inside to outside layer.

This capacity calculation neglects the "edge effect" which may increase the actual capacity over that given by Eq. (36) by as much as 100 per cent, depending upon the shape of coil.

In calculating the separation of the inner and outer layers the thickness of wire in the intermediate layers must not be included; thus if the space between the surfaces of the wires of two adjacent layers is 0.5 mm. and there are ten layers, the space between the inner and outer layers is 4.5 mm.

To keep the capacity low it is very necessary to keep the adjacent layers separated by an appreciable air space; if this space is too small the internal capacity is high, and the coil cannot be used at as high a frequency as it is possible with a coil of equal inductance having a low internal capacity. If paper, oiled cloth, wax, shellac, or similar dielectric is used to separate the different layers there will be an appreciable dielectric loss in this material (thereby decreasing the efficiency of the coil) and the internal capacity will be increased by a factor equal to the specific inductive capacity of the material used. The bad effects of the dielectric used between layers increase as the amount of external tuning capacity is decreased.

It might seem from the previous reasoning that a large air space would be advisable, but such is not the case; as the air space is increased the value of inductance for a given amount of wire is decreased, the ratio of L to R being greater the more compact the coil. Just what air space is best the author has not determined, but with a coil made of well-stranded radio-cable an air space equal to the diameter of the cable has seemed suitable.

Natural Period of Multilayer Coils.—It is possible to calculate the natural period of the air-spaced coils with a fair degree of precision, perhaps within 10 per cent. The capacity to be used in making the calculation is considerably greater than the value given in Eq. (36) because of the edge effects and a redistribution of potential in the coil. For some coils having a square cross-section of winding, outer radius about 30 per cent greater than the inner radius, the natural period could be determined by using for L its low-frequency value and for C just twice

the value calculated from Eq. (36). As examples of how well the prediction may be made the data for two coils are given herewith.

	Coil No. 1.	Coil No. 2.
Inner radius	4.7 cm.	4.7
Outer radius	5.5 cm.	6.3
Axial length of coil	2.5 cm.	2.5
Number of layers	10	18
Number of turns (total)	736	740
Air space between layers060 cm.	.033 cm.
Calculated capacity, Eq. (36)	14.2×10^{-12}	16.2×10^{-12}
Low frequency inductance	66.2×10^{-3}	72.2×10^{-3}
Calculated natural frequency	1.09×10^6	1.11×10^6
Measured natural frequency	1.16×10^6	1.05×10^6

The natural period of a multilayer coil does not increase rapidly with increase in inductance. Thus if the number of layers in such a coil is doubled, the inductance is increased nearly four times, but, as the capacity has been decreased to only half its previous value, the natural period has been increased only about 40 per cent.

CHAPTER III

GENERAL VIEW OF RADIO COMMUNICATION

Wave Motion.—Since the transmission of intelligence by radio is brought about by sending out so-called electromagnetic waves, and since the transmission of these waves is somewhat similar to that of other kinds of waves, such as light, sound, heat, water, etc., we will first discuss wave-motion in a simple manner and then apply this to electromagnetic wave-motion.

In wave-motion a stress is transmitted from one point to another in an elastic medium without any permanent displacement of the medium itself in the direction in which the stress is transmitted. Thus, if a pebble be dropped in a still pond at *A*, an up-and-down motion of the water will be set up at *A*, which will be transmitted to a point at *B*, without any motion of the water itself in the direction *A-B*, as evidenced by the fact that a float placed between *A* and *B* will not be displaced toward *B*.¹

In the case of water waves the pebble dropped at *A*, Fig. 1, will displace the water directly under *A* to the right and left (in fact in all direc-

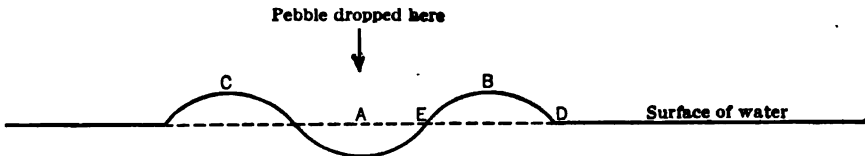

FIG. 1.—Cross-section through surface of water, immediately after pebble has been dropped at *A*.

tions) towards *B* and *C*, and will produce the bulges at *B* and *C* known as "crests." These bulges are due to the fact that the water displaced from *A* tends to raise the level all around *A*, but, on account of inertia, this cannot be done quickly enough, with the result that the level is raised most at *B* and *C*, and hence the "crests."

Considering the disturbances to the right of *A* alone, the particles of water in the space *EBD* will, because of gravitational forces, seek the average level of the water, and, in so doing, the bulge *EBD* will be made to

¹ If a wave is so high as to "break," i.e., an impure wave, this statement is not quite true.

disappear, and a depression will be created thereat due to the fact that, on account of inertia, the particles move beyond the average "level position." Not only is this the case, but the particles to the right of D will, one after the other, be urged, as if elastically tied together, to perform motions similar to those of the particles within EBD , so that a crest will presently appear to the right of D at the same time that a depression or "trough" is created in the region EBD . The result is that a "trough" and a "crest" of a wave will *appear to move* in all directions, away from the center of disturbance at A , and with a definite velocity.

It must be understood that the motion of the particles is limited to a small region around their positions of equilibrium, and that the wave is propagated by imparting this motion to one particle after the other, while each particle, after the disturbance has passed, remains in practically the same position as it originally occupied.

An exact analysis of the motions of the particles is extremely complex and will not be attempted here, but we will give certain well-known elementary facts regarding it because of the analogy between certain points regarding water waves and electromagnetic waves.

Theory indicates and experiment corroborates that the water particles within the path of a wave execute motions which are in the simplest cases circular. Taking this case of circular motion of the particles and considering Fig. 2, at C a particle of water will just be passing through the

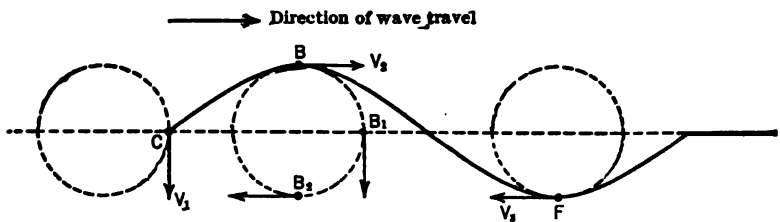

FIG. 2.—Motion of the water associated with a wave.

undisturbed level and moving with a velocity V_1 in a downward direction, while at B another particle will be moving with a velocity V_2 in a horizontal direction. Thus, at every point within the volume of the water involved in the wave propagation each and every particle will be executing a circular motion in a clockwise direction, and the formation of a crest or trough is the result of various particles being, at any time, at different stages of their circular motions. Thus where the particles are moving horizontally in the same direction as that in which the wave is being propagated we obtain a crest, since a large number of particles are then at or near the top of the circle; where the particles are moving horizontally, but in a direction opposite to that of the propagation of the wave a

trough is obtained, since a large number of particles are then at or near the bottom of the circles representing their respective motions.

Consider now the question of energy of a particle at B ; it has a velocity in the direction of the propagation of the wave, and, furthermore, it is displaced vertically upward with respect to the undisturbed level of the water; such a particle has kinetic energy in the direction of the wave propagation plus potential energy with respect to the average level. As the particle rotates the vertical displacement from the average level becomes less and less and so does the component of its velocity in the direction of propagation of the wave; so that when it occupies the position B_1 , its potential energy has become zero and so has the kinetic energy in the direction of the wave propagation. As it moves still further it suffers a negative displacement and its velocity acquires a component parallel to direction of propagation of the wave but opposite thereto, so that by the time it has reached the point B_2 its potential and kinetic energy are equal and opposite in sense to those which it had while at the point B .

It may be shown that the potential energy of a particle at any point is exactly equal to the kinetic energy in the direction of propagation of the wave, provided that the wave is not changing shape. Because of this there must be a fixed relation between the displacement of a particle above or below the undisturbed level of the water and the component of the velocity of the same particle parallel to the direction of propagation of the wave.

Again, the total energy of a particle of water (potential and kinetic in the direction of propagation of the wave) is continually changing as the wave progresses, the particle in question passing its energy along to the particle adjacent to it, in the direction of the wave propagation; this transfer of energy from one particle to another is the underlying principle of all wave motion in water.

Electromagnetic Waves. — These are due to a disturbance of an electromagnetic nature and are such that they produce at points all around the center of disturbance a varying magnetic field and a varying electric field. Thus, if a wire, such as AB (Fig. 3) in space, has an alternating current flowing through it for a short interval of time it will set up an alternating magnetic field and an alternating electric field all around itself, which fields, starting from the vicinity of the conductor, will travel away from it with

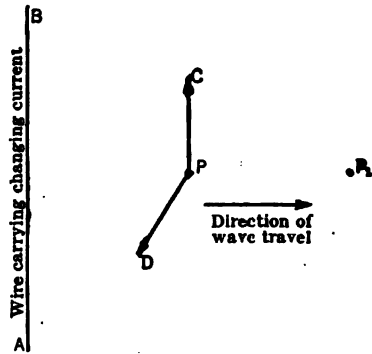

FIG. 3.—Electric and magnetic fields set up at P by wire $A-B$.

the velocity of light. In so far as to set up a magnetic field or an electric field requires energy, it follows that a certain amount of energy must be detached from that available in the conductor in order that the electromagnetic disturbance be created at all. Thus energy is said to be "radiated," and the phenomenon itself is known as "electromagnetic radiation" or simply "radiation."

The electric and magnetic fields of radiation, at any one point, are in space quadrature, but they are at all times in time phase with each other. And not only is this the case, but there is a fixed relation between the values of the electric and magnetic fields at any instant; this relation is based upon the fact that, in order for the wave of electromagnetic disturbance to exist in space the energy, per unit volume of the medium, possessed by the electric field, must be equal to that possessed by the magnetic field. Thus the total amount of energy at any one point and instant is equal to twice that possessed by either field. The value of this energy is changing as the intensity of the two fields changes, and, as a matter of fact, the energy is being transferred from one point to the next by the elastic properties of the medium in which the disturbance travels. (The discussion of electromagnetic waves here given uses the idea of a medium as a carrier of the disturbance; to make this medium fill the role it is supposed to play in modern electron theory it must be considered as the superimposed electric fields of all the electric charges in the universe.) The reader will note that this is analogous to the case of water waves, where, at any point, the potential energy per unit volume is equal to the kinetic energy in the direction of propagation of the wave, and the total amount of energy is transferred from point to point within the medium, thus bringing about the conditions of wave motion.

In the case of water waves or electromagnetic waves if, at any point, some of the energy in one of the two forms (potential and kinetic for water, and electric and magnetic for electromagnetic waves) be withdrawn from the space wherein the wave exists, part of the energy in the other form will be immediately transformed into the former, with the result that equality of the two forms of energy will still apply, but the crests and troughs of the water waves will not be as high as before, nor will the amplitude of the electric and magnetic field intensities be as large as before.

It must be noted that this phenomenon is different from that of the creation of the ordinary magnetic or electric field around the conductor, which field never reaches far from the conductor (with appreciable intensity), and does not represent energy permanently removed from the conductor, since the variation of this field induces electromotive forces in the conductor, and thus an *exchange of energy* is kept up between the conductor and the field. This field is known as "induction field" to dis-

tinguish it from the "radiation field," wherein we are more vitally interested.

In the case of the "radiation field" at any point such as *P*, Fig. 3, the magnetic field would act along *PD* and the electric field along the line *PC* at right angles to *PD*, while the disturbance would travel in the direction of the arrow at right angles to both *PC* and *PD*. Both fields change in value and in direction in accordance with the variations of the current in the conductor producing the disturbance; if this is harmonic the two fields will change harmonically. At some other point such as *P*₁ the disturbance will arrive a little later than at *P* with the result that the fields at *P* and *P*₁ are out of phase, the phase difference depending upon the frequency and the velocity of propagation.

Considering one of the two fields, say the magnetic, and plotting the instantaneous value of the field against distance from the conductor of Fig. 3 we would obtain a curve such as *A* in Fig. 4, which applies to any

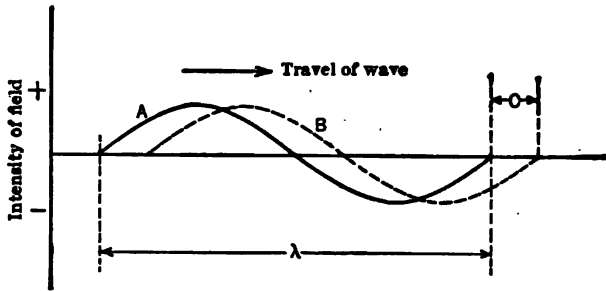

FIG. 4.—Illustrating one "wave length."

particular instant of time. A little later the plot of the field would be given by the curve *B* in so far as the intensity at every point in space will by then have varied so as to make the new curve possible. The wave has thus been shifted in the direction of the arrow by the amount *C*. If we plot a number of such curves we would find that the wave has shifted the distance λ , by the time the magnetic field has completed a cycle. We thus have that if:

- λ = wave length in cms.;
- v = velocity of propagation of wave in cms./sec.;
- f = frequency of the field in cycles/sec.;

Time for one cycle = $\frac{1}{f}$

and $\lambda = \frac{1}{f}v;$
 or $v = \lambda f, \dots \dots \dots (1)$

which is the fundamental relation for any wave propagation.

Velocity of Propagation.—For electromagnetic waves this is equal, as already stated, to the velocity of light when the wave is being propagated through air, but in general, for any medium, we have the following:

- V = velocity of light in vacuum;
- v = velocity of propagation of wave in any homogeneous medium;
- μ = magnetic permeability of the medium;
- k = specific inductive capacity (inductivity of medium).

$$v = \frac{V}{\sqrt{\mu k}}, \dots \dots \dots (2)$$

since for air $\mu = 1$ and $k = 1$, $v = V$.

This formula neglects any possible effect on the velocity of propagation, of any losses occurring in the medium, due to conduction, hysteresis or dielectric losses, etc.

As shown by Eq. (2) the velocity of propagation is dependent only upon the nature of the medium through which the wave is moving (its magnetic and electric constants), and is not effected by the wave length or by the frequency. Thus, in considering the conductor AB of Fig. 5,

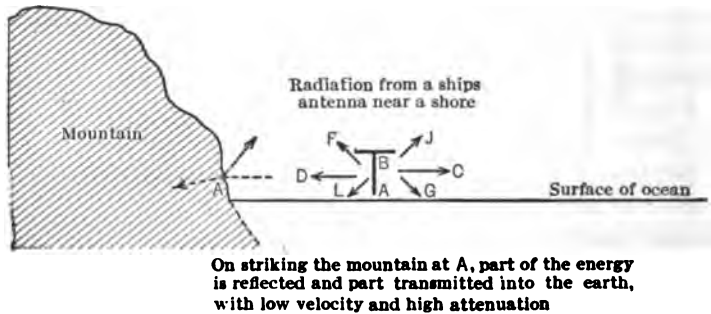

FIG. 5.—Energy radiated from an antenna is subject to the same laws of reflection, refraction, and absorption as ordinary light.

as the source of an electromagnetic wave, this wave would spread out in the direction of C with the velocity of light, but in passing through the mountain to the left the velocity would be lower. If instead of a mountain we should have a sheet of metal for which the value of k is infinitely large, then:

$$v = \frac{V}{\sqrt{\mu \infty}} = 0,$$

that is, the wave would stop completely;¹ the energy of the wave would

¹ This conclusion is not strictly accurate; the velocity in such a case would be much less than the velocity of light, but would not be zero. The discrepancy arises from the very elementary viewpoint from which wave motion is here considered.

be partly absorbed by the metal in the production of electric currents therein and partly reflected back. Not only would the wave travel in the direction *C* and *D*, but in every other direction, up into the air in the direction of *F* and *J*, and into the water and earth in the direction of *L* and *G*.

As the wave travels outward some of the energy is absorbed by the medium if this be other than air; even in air there is some absorption of energy, especially in daylight, due to ionization making it partially conducting; and, in other materials, losses are produced by the varying electric and magnetic fields which absorb energy from the wave itself. The result of this is, of course, that a distance is soon reached where practically no more energy is available and the disturbance ceases to be communicated (in measurable intensity) any further. The distance over which a certain amount of energy will travel through air, even in daylight, before being absorbed is, of course, much greater than through solid matter or even liquid, due to the fact that the losses (eddy currents, magnetic hysteresis, dielectric hysteresis, etc.) are greater than in air.

In cases where a wave travels in the direction of *C* (Fig. 5) through the air there are parts of the wave which are close to the water (or earth, as the case may be); it follows (from Eq. (2)) that these parts cannot travel as fast as the rest and, therefore, lag behind, and the surface bounding the advancing wave in the air is distorted, the parts nearer the water reaching a given distance from the transmitting station later than some other part of the wave which is more distant from the absorbing medium (earth, or sea). This makes the wave front "lean over" as the wave advances.

Various Types of Waves.—While the discussion given above has been of a purely theoretical nature, the reader will understand that in radio communication it is by means of electromagnetic waves that the transmission of intelligence is effected, and that these waves are produced by sending suitable currents through one or more suitably arranged wires forming what is known as the "antenna," or "radiating system." Thus, an operator at the transmitting station will, on depressing a key, send through the radiating system a current which will start an electromagnetic disturbance and cause an electromagnetic wave to be "radiated." Such a wave will travel in air with the velocity of light and produce all around the radiating system an alternating electric field and an alternating magnetic field which may be made, at a suitable receiving station, to actuate suitable instruments for the detection of such a wave; and in this manner the pressing of the key at the transmitting station will be signaled to the receiving station. The details of a transmitting and receiving set are given later on in this chapter and further discussed in other chapters.

Various types of electromagnetic waves may be sent out by a radiating

system, depending upon the kind of current used to produce the waves. Thus, two systems of radio transmission are at present in use, which are distinguished by two different kinds of waves. These are known as "Undamped wave" and "Damped wave" systems. In the former the current which is made to flow through the antenna when the operator presses his key is an alternating current of constant amplitude (undamped), so that the waves produced are such that at any point in space the maximum value of the intensity of the electric field and of the magnetic field is constant as long as the wave is passing.

In the "Damped wave" system, on the other hand, the current sent into the antenna at the pressing of the key may be represented by the graph of Fig. 6, from which it may be seen that the waves are sent out in "trains," each train consisting of a number of waves of diminishing amplitude; so that at any point in space the maximum value of the intensity of the electric and magnetic fields will not be constant but will be damped.

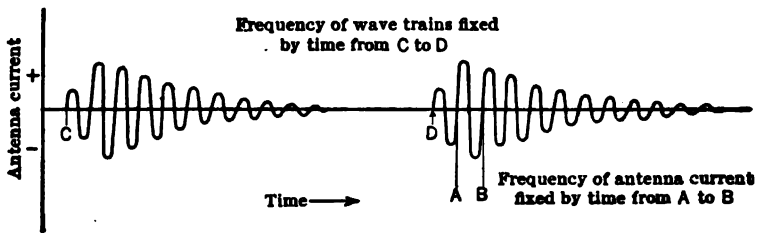

FIG. 6.—Type of antenna current in a spark station.

The frequency used in radio transmission either for the undamped or for the damped waves is very high, because more power is radiated by an antenna at high than at low frequencies. If the currents used for radio transmission were passed through the coil of a telephone receiver, no audible sound would be produced, because the diaphragm could not vibrate at such a high frequency and, even if it did vibrate, the human ear would be unable to detect any sound. Such frequencies are said to be beyond the limit of audibility and are known as "radio-frequencies," while the frequencies which may be "heard" are known as "audio-frequencies." There is no distinct line of demarkation between these two frequencies, but it may be stated in a broad manner that the audio-frequency range is between 40 and 10,000 cycles per second while the radio-frequency range is between 10,000 and 3,000,000 cycles per second or over.

In view of the fact that in radio-transmission the frequency is a large number it is more customary to speak of the wave-length of a wave rather than of its frequency. The wave-length is generally expressed in meters, Eq. (1) of p. 183 states

$$v = \lambda f$$

or

$$\lambda = \frac{v}{f}.$$

If v is in meters per sec. and f in cycles per sec., then λ is in meters.

Since $v = 3 \times 10^8$ meters per second the wave-length for 10,000 and 3,000,000 cycles per sec. may easily be found to be

$$\lambda = \frac{3 \times 10^8}{10^4} = 30,000 \text{ meters}$$

and

$$\lambda = \frac{3 \times 10^8}{3 \times 10^6} = 100 \text{ meters.}$$

Thus the wave-length range for radio-transmission is 30,000 to 100 meters.

The wave-lengths which have been found most suitable for various kinds of work at present are as follows:

- 10,000 to 20,000 meters for trans-oceanic communication;
- 1000 to 10,000 meters for distances between 300 and 1000 miles;
- 450 to 1000 meters for distances between 50 and 300 miles;
- Less than 450 meters for short distances.

Spark Telegraphy.—In the past the production of high-frequency currents required for radio-transmission has been largely accomplished by utilizing the high-frequency oscillatory discharge of a condenser associated with a suitable radiating circuit. As the energy initially stored in the condenser is dissipated in the primary circuit and associated circuits, the condenser must again be charged and the cycle repeated. In order that the condenser may be charged to the high potentials required for large energy storage, and to permit its discharge in a suitable closed circuit of low resistance, that circuit must contain an element whose resistance is very high during the charging period, but whose resistance decreases instantaneously when the condenser discharges and remains at a very low value during the period of discharge. This requirement is fulfilled by the ordinary spark gap, the resistance of the gap being very high before breakdown occurs, but decreasing to a very small value when the gap has broken down under the increasing potential impressed across its terminals. The spark gap and spark are thus essential to transmitters generating high-frequency oscillations by means of condenser discharges, and this system is therefore designated as "spark telegraphy." The connections of such a transmitter are indicated in Fig. 7.

The detailed action of this transmitter is discussed in Chapter V, and is therefore omitted here. By operating the switch, or key, in the alternator circuit, the radiated energy may be interrupted, and if this is done in accordance with a prearranged code, signals may be transmitted to

the distant receiving station. For low-powered stations a storage battery and small induction coil take the place of the alternator and transformer.

Spark telegraphy is distinguished by the fact that the high-frequency oscillations are damped, successive oscillations decreasing in amplitude to zero. The series of oscillations occurring with each discharge constitute a train of waves, and the number of such trains produced per second is known as the group, or wave-train, frequency, which in practice may be from 100 to 1000 per second.

Continuous Wave Telegraphy.—Transmission of signals by means of undamped high-frequency oscillations possesses several advantages, and this system is rapidly superseding the spark system for large stations of

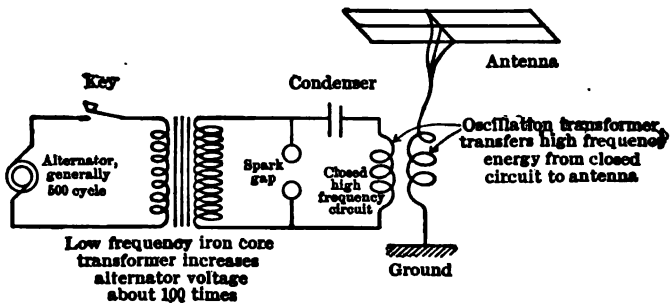

FIG. 7.—Typical connection scheme of a spark transmitting station.

high power, long range, and utilizing the lower radio frequencies. Chief among the advantages obtained are:

1. A given amount of power in the form of a continuous wave signal will in general give a louder response in the telephone receivers than would the same amount of power in the form of spark signal (due to the characteristics of the receiving circuits).
2. Due to the scheme of reception the interference between stations is much less for continuous waves than for spark waves.
3. To radiate a given amount of power requires less voltage on the antennæ (hence cheaper antennæ construction) for continuous waves than for spark waves, due to the fact that in one case energy is being continuously radiated, and in the other case for a small fraction of the time only.

Undamped oscillations may be generated by the high-frequency alternator (Alexanderson and Goldschmidt types), the Poulsen arc, a scheme utilizing saturated iron cores, or the oscillating vacuum tube; all act to send through the antenna circuit an undamped high-frequency current. This current may be varied by means of a key, which may interrupt the supply to the antennæ, or change the frequency of the oscillations

slightly by varying the inductance of the circuit. Both methods are not equally applicable to all means of generation. (See Chapter VII.)

Radiotelephony.—The war very greatly stimulated the development of the radio telephone because of the necessity which arose of providing a rapid and direct communication between aeroplanes and the ground at all times, vessels of a group of submarine chasers, etc. This need could be fulfilled satisfactorily only by the radio telephone, and its development on a practical basis was accordingly greatly accelerated. This refers particularly to small power sets of low range. In 1917 radiophone messages had been successfully transmitted to land stations at Honolulu and Paris from Arlington, U. S. A., and in 1919 successful radiophone communication was established between Washington and steamships while the latter were still several hundred miles at sea, and also between ground stations and flying aeroplanes many miles distant.

To transmit radiophone messages between distant stations requires the same equipment utilized in continuous wave telegraphy, i.e., a generator of undamped oscillations and associated antenna, plus a "modulating" element whose function it is to vary the amplitude of this high-frequency current in accordance with the sound waves of the voice. Fig. 8 shows the fundamental idea clearly; the amplitude of the high-frequency current flowing in the antenna (and therefore the power radiated) is varied in accordance with variations in the transmitter resistance, which in turn is dependent on the sound vibrations, as sent out by the speaker, impinging on its diaphragm.

The problems of radiotelephony are those met in connection with the generation of undamped high-frequency alternating currents and the modulation of their amplitude in accordance with speech waves.

Receiving Station.—The receiving station consists of an antenna and associated equipment, which may be tuned so as to absorb a maximum amount of the energy of the incident electromagnetic waves radiated by the transmitting station.

Coupled to the antenna is a secondary circuit, also tuned to the incoming wave length, and to which is connected the *rectifier* and phones required to make the incoming signal audible to the receiving operator. The complete connections of a receiving station, consisting of the foregoing elements, are shown in Fig. 9.

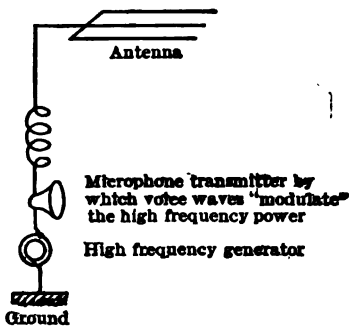

FIG. 8.—Illustrating possibility of varying the amplitude of the high frequency current in an antenna, by the voice waves.

As previously mentioned, by tuning the antenna and secondary circuits to the frequency of the received oscillations, using the variable condenser or inductance, or both, as required, a maximum amount of the power transmitted by the incident electromagnetic waves, will be transferred to the receiving circuits. Under these conditions a maximum current flows in the secondary circuit and hence a maximum voltage will exist across the terminals of the inductance (L_2).

The detecting circuit, consisting of the rectifier and phones, and connected across the coil, will thus have a maximum flow of current through

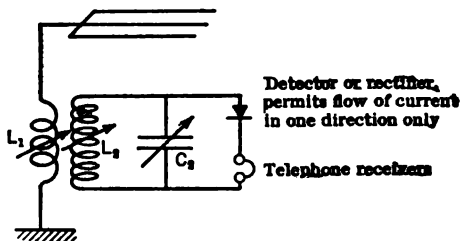

FIG. 9.—Typical receiving station circuit, for reception of spark signals.

it. The rectifier so acts as to permit current to flow in only one direction, having a much higher resistance in one direction than in the other. For one group of waves, a unidirectional pulse of current is thus sent through the phones. Therefore, as the wave trains strike the antennæ, pulses of current flow through the phones, the diaphragm of which is thus impulsed at group frequency. These pulses, following one another with the same rapidity as the sparks occur at the transmitting station, give in the telephone a musical note, the duration of which depends upon how long the operator at the transmitting station holds down his sending key.

The receiving circuit described above will receive only damped wave signals or radiotelephone messages. For undamped wave signal reception a special receiver is necessary, as the pulse effect obtained with damped waves is absent, and radio frequencies are too high to be able to move the phone diaphragm, due to its inertia. Even if an appreciable movement of the diaphragm were obtained, no signaling could be accomplished, as the radio frequencies used are above audibility.

The reception of undamped wave signals is at the present time most successfully accomplished by producing "beats" of audible frequency, as is done by the "heterodyne" receiver, embodying a local high-frequency generator combined with a rectifying device. The dual functions of this receiver are admirably fulfilled by the vacuum tube and its associated circuits as illustrated in Fig. 127, p. 514. Various arrangements, as described in Chapter VIII, have been used to mechanically break up the steady, high-frequency oscillations into groups occurring at audio frequency, the most prominent of these devices being the Goldschmidt tone wheel. Due to its greater selectivity, simplicity, and sensitiveness, the heterodyne receiver using a vacuum tube as

the generating and detecting element is rapidly superseding these earlier forms.

Selection of the Desired Signal.—Since a number of other transmitting stations, within range, may be sending, simultaneously with the station the signals of which it is desired to receive, the receiving circuit must possess the ability to “tune out” these other signals which are reaching the station, and “select” that signal sent by the transmitting station with which it is desired to communicate. Without this means of selecting a desired signal to the exclusion of others which would be received at the same time, the operator would hear only a confusion of dots and dashes sent by all the different stations.

It has already been shown in Chapter I how the current in a circuit containing inductance, capacity, and resistance, is made a maximum, when the natural frequency of the circuit is adjusted to coincide with the frequency of the impressed e.m.f. This effect is graphically indicated by the resonance curve plotted in Fig. 53, Chapter I. The adjustment of the antenna circuit to the frequency of the incoming oscillations, represents an analogous operation, and is called “tuning” the antenna circuit. Thus, by tuning to the frequency of the signals which it is desired to receive, the current due to this signal is made the maximum, while the currents flowing in the antenna due to signals sent out from other stations, which have a frequency different than that of the signal being received, are relatively much weaker.

The secondary circuit, being also “tuned” to the frequency of the signal desired, will still further diminish those currents due to the interfering transmitting stations, while the current of signal frequency will be a maximum. This, as pointed out previously, results in a maximum voltage being impressed on the detector-phone circuit, resulting in maximum rectified current in that circuit, and maximum strength of the signal which it is desired to receive.

Interference.—The confusing and clouding of the desired signal due to signals simultaneously received from undesired stations within whose range the receiving station is operating, is called “interference,” and, as pointed out, this “interference” is eliminated in practice by careful tuning of the several circuits. Several factors determine the extent of this interference and the completeness with which it may be tuned out.

First. The amount by which the radio frequency of the desired signal differs from the radio frequencies at which the interfering stations are sending. If they are widely different, tuning will effectively eliminate the interfering signals. Where the frequencies are nearly the same or are the same, it is impossible to tune them out completely and differentiation must then be accomplished by means of the characteristics mentioned below; viz., relative loudness or pitch of the signal note.

Second. The relative strength of the desired signal and signals received from interfering stations. When the interfering station is relatively close to the receiving station, thus producing heavy interference, the reception of the desired signal may be extremely difficult, even though the frequency of the interfering station may differ to a considerable extent from that for which the circuit is tuned.

Third. The pitch of the signal note heard in the phones, as determined by the group frequency of the several transmitters in operation. If the pitch note of the desired signal is distinctive, as compared to the notes of the interfering stations, then the signals may be read "through the interference" and the message obtained. This would be the only feature whereby the signal could be distinguished if the radio frequencies of the several stations agreed closely and the interfering stations were relatively close to the receiving station.

Simultaneous Sending and Receiving.—In the development of radio-telephony one of the problems to be met was the elimination of the necessity of any action on the part of the subscriber, required to change over from sending to receiving and vice versa. A simple method of duplex operation, as described by E. F. W. Alexanderson,¹ is included at this point to show the possibility of using radio communication in exactly the same way ordinary telephone communication is carried on.

The arrangement utilizes separate sending and receiving antennæ, located sufficiently far apart, and having natural frequencies differing from one another a sufficient amount, to make the operation stable. The general arrangement is indicated in Fig. 10, wherein it will be noted that the radio system has the same relation to the subscriber as the toll line in wire telephony.

A radio telephone current set up in the receiving antenna, due to excitation from the distant transmitter, is transformed into a current flowing in the closed circuit between the subscriber's instrument and the transmitting station. The same path is followed by a telephone current originating in the local subscriber's station. Therefore the current set up in the local receiving station, due to a signal from the distant transmitting station, will be retransmitted by the local sending station in the same way as the current set up by the local subscriber station, and consequently, both sides of the conversation are transmitted by each station and could be overheard by a third party tuned to either of the two wave lengths used.

If the amplification of the received signal were made too great, so that the telephone current set up by the speaker came back to him in intensified form, a cumulative reflective action would be created, which would result in self-exciting inarticulate oscillations being set up. Any

¹E. F. W. Alexanderson, "Simultaneous Sending and Receiving," Proceedings of the Institute of Radio Engineers, August, 1919.

trouble from this source may be effectively eliminated, however, by keeping the amplification within a certain critical value, whereby the retransmission becomes effectively damped.

Static, Strays, or X's.—In addition to the interference which may be produced by the operation of other transmitting stations as described above, natural electrical disturbances occurring in the atmosphere also cause serious interference in the reception of signals. These disturbances set up electromagnetic waves, which, upon striking the receiving antennæ, set up troublesome, interfering sounds in the phones, to which the name

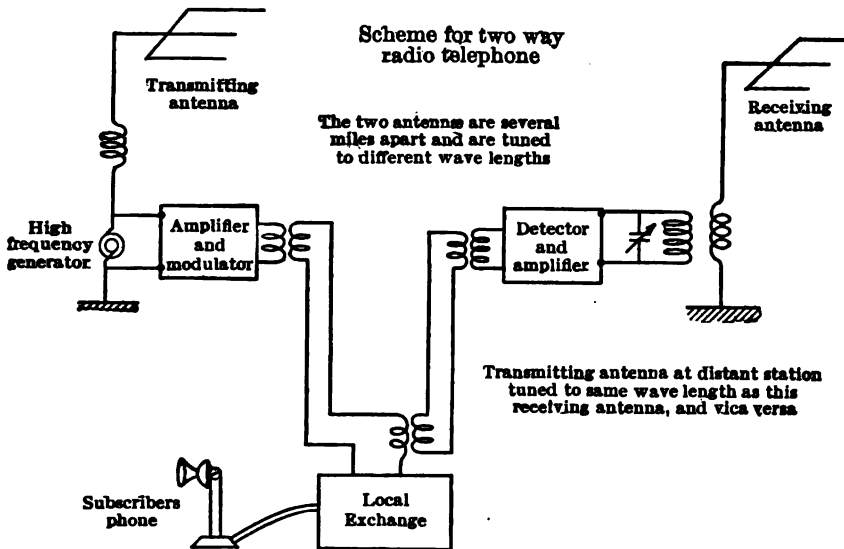

FIG. 10.—Modern scheme for two-way radio telephone communication.

static, strays, or X's have been variously applied. These strays have been arbitrarily placed by De Groot¹ in the following classes:

- (a) Loud and sudden clicks. These do not interfere seriously when no other interference effects are present, and have been shown to originate in nearby or distant lightning discharges.
- (b) A constant hissing noise in the receivers, giving the impression of a softly falling rain, of the noise of water running through tubes. This type occurs occasionally when there are dark, low-lying electrically charged clouds near the antennæ, and is apparently caused by intermittent, unidirectional currents in the antennæ. Charges of electricity come upon the antennæ

¹ "On the Nature and Elimination of Strays." Proc. I. R. E., April, 1917.

from the atmosphere through direct physical contact, and thence discharge to ground, producing a current.

- (c) This type produces a continuous rattling noise in the telephone, something like the tumbling down of a brick wall, and are usually present to a greater or less extent. In the tropics, where interference from static is especially severe, this type predominates, and is always present. It is frequently so severe as to prevent entirely the reception of signals. Strays are most prominent at night, but are not so troublesome at that time, due to the great increase of signal strength.

Their intensity and character is a function of the time of day, the season of the year and the location of the station; thus, in the tropics, De Groot found the most unfavorable time was that of the trade wind. In general, the worst trouble is experienced when the sun's altitude is highest. Their intensity is probably dependent somewhat on the dryness of the air and wind conditions, increasing dryness and high-wind velocities increasing interference due to this cause.

Elimination of Strays.—It has been described how interference, due to simultaneous operation of other transmitting stations within range, may be minimized or eliminated by selective tuning, provided the wave lengths are not too closely in agreement, and the signals received from the interfering station are not too strong. This means also fails if their decrements are high. It may be noted that very powerful or strongly damped waves act like an impact excitation of the receiving circuits, which are set into oscillation at their own natural frequency. This response is secured regardless of the wave length of the incoming highly damped oscillation; for this reason the circuit is not selective to these waves. Stray waves are always highly damped, and may be very much stronger than the incoming signal waves. Therefore, their elimination cannot be satisfactorily accomplished by selective tuning, but some other arrangement must be used which results in their neutralization.

A neutralization scheme, suggested by De Groot, is shown in Fig. 11; many similar arrangements have been recommended.

Antennæ No 1 and No. 2 are similar, but the former is tuned to the radio frequency of the incoming signal, while No. 2 is practically untuned because the detector D_2 is inserted directly in the circuit; the circuit is made nearly aperiodic and signals from distant stations are impossible of reception by this antenna. The reception of static signals is just as strong, however, as are obtained with the tuned antenna.

The receiving circuits of both antennæ are coupled together and to a third circuit containing the phones and condenser (this condenser is used for tuning the phone circuit to the audio-frequency), this coupling

being arranged so that the static currents tend to neutralize one another, leaving only the received signal current to act on the third circuit.

A later arrangement, as developed by R. A. Weygant,¹ is based on the inventor's belief that static disturbances of the third type specified above are propagated in a direction perpendicular to the earth's surface, whereas the signal waves are transmitted parallel to the earth's surface (horizontally). Two loop aerials were used in the experimental work, located about 5000 feet apart, the plane of the loops being vertical. The waves due to static cut both loops in phase, whereas the signal waves, traveling horizontally, induced e.m.f.'s in the two loops, which were out of phase by an amount depending on the separation between the two

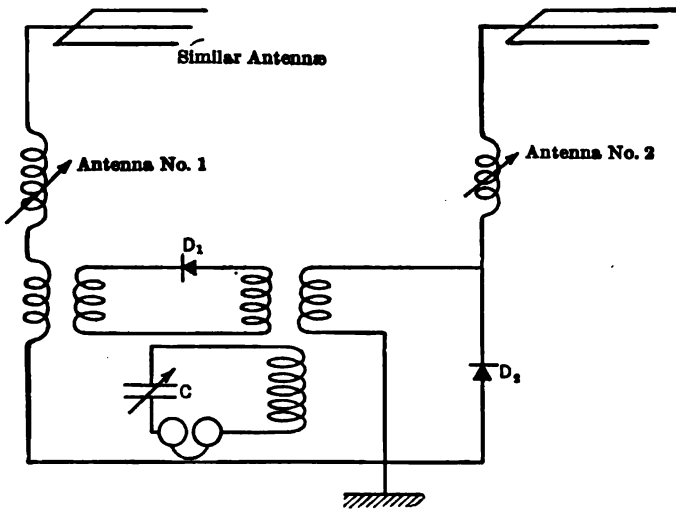

FIG. 11.—One of the early attempts to eliminate "strays."

loops expressed as a fraction of the signal wave length. By coupling the two circuits to a third receiving circuit, the static effects are eliminated, while the signal currents combined vectorially to give a resultant which, in turn, is rectified by means of a vacuum-tube detector.

A. H. Taylor reports very successful results in the elimination of static by suitably balancing the signals received by an under-water (or buried) single-wire antenna with that received from an overhead antenna, generally of the coil type. His results would indicate that, using his scheme, transatlantic radio communication is assured under any condition of static to be expected.

Probably one of the most promising lines of development in the elimination of static interference has to do with a vacuum tube detector which, even with the heaviest static, can give but limited response in the telephone

¹ Roy A. Weygant, "Reception through Static and Interference," Proceedings of the Institute of Radio Engineers, June, 1919.

receiver; if this response is not more than two or three times as loud as the signal a good operator can read the signal right through the interfering noises.

Attenuation of Propagated Waves.—The electromagnetic waves set up by the transmitter are propagated in all directions through the ether at a velocity corresponding to that of light, as discussed in the earlier portions of this chapter. As the distance from the transmitter increases their amplitude or intensity decreases, due to the wave spreading out in ever-widening circles and energy absorption by the different media through or over which the wave may be propagated. This decrease in intensity, expressed in terms of the initial intensity at the source, is called the attenuation of the wave.

Many investigations have been made to determine the attenuation of these waves, among the more important of which may be mentioned those carried out by L. W. Austin¹ in 1909–1910, using the station at Brant Rock, Mass., as the receiver and the transmitting sets on U. S. cruisers for sending. His results cover one special case only, namely, transmission during daylight over sea water. The variation of currents flowing in the receiving antennæ is indicated in Fig. 12. The dotted curve is plotted to show what the results would be if no absorption of energy had occurred, in which case the received current would have been nearly inversely proportional to the distance from the source.²

Through the points, obtained from the experiments, the full-line curve was drawn, as shown by Fig. 12, the equation of which as deduced by Austin, is as follows

$$I_r = AI_s \cdot \frac{h_s h_r}{d\lambda} \cdot \epsilon^{-0.0015 \frac{d}{\sqrt{\lambda}}}$$

where A is a constant;

I_s is the effective current in the transmitter antenna;

I_r is the effective current in the receiver antenna;

h_s is the height of the transmitting antennæ;

h_r is the height of the receiving antennæ;

d is the distance between the two stations;

λ is the wave length of transmission.

All lengths are expressed in kilometers.

For the ranges covered by Austin's investigation, namely:

$$I_s = 7.0 \text{ to } 30.0 \text{ amperes}$$

$$h_r \text{ and } h_s = 12 \text{ to } 40 \text{ meters}$$

$$\lambda = 300 \text{ to } 3750 \text{ meters}$$

$$d = \text{up to } 1500 \text{ kilometers}$$

the constant A was found to be equal to 4.25.

¹ L. W. Austin: Bull. Bureau of Standards, vol. 7, p. 315, 1911 and vol. 11, p. 69, 1914.

² More recent tests by Vallauri on the strength of signals received at Leghorn from Annapolis indicate that the attenuation is much less than Austin's formula predicts. Vallauri's measurements gave a field strength at his receiving station about ten times as great as the value calculated from Austin's formula.

The receiving antenna resistance was 25 ohms.

Day and Night Variation in Signal Strength.—The foregoing investigation considered day conditions. At night, due to variations in atmospheric conditions, affecting the conductivity of the upper strata, the energy losses in transmission are decreased, and the attenuation of the wave is correspondingly diminished. In practice it is generally found that transmission is very much more effective at night than in the day-

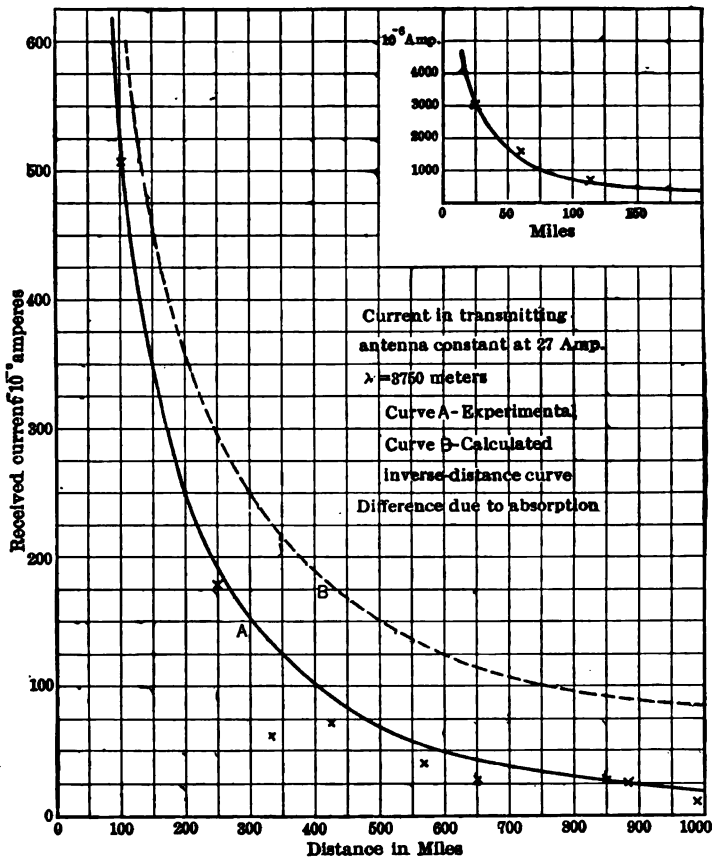

FIG. 12.—Calculated and experimental values of current in receiving antenna, as distance from transmitter is increased.

time, the range of transmission being sometimes increased two and one-half times or more. The transmission, however, is very much more uncertain, the range sometimes being only slightly greater than in the daytime.

The electromagnetic waves are generally believed to be propagated through the layer of atmosphere immediately adjacent to the earth's surface, this layer being considered about 30 to 40 miles thick. Above this,

the atmosphere, due to this low density, and the ionizing action of the sun's rays, rapidly increases in conductivity, and forms a bounding plane, of high conductivity, for the layer of atmosphere adjacent to the earth, whose resistance is comparatively high.

During the day, however, this layer adjacent to the earth is also ionized to a small extent, increasing its conductivity and decreasing the efficiency of transmission of the electromagnetic waves, which is a maximum for a dielectric possessing zero conductivity. With the removal of the sun and its ionizing effects on this transmitting layer of atmosphere, this efficiency is increased and thus also the range of transmission. During daylight the refracting effects of the upper ionized portion of the transmitting layer cause the waves to bend over, so that when they reach the receiving antennæ they may be bent at such an angle as to have very little effect on the aerial. This effect is diminished at night, when the ionization of this transmitting belt is largely reduced, as already described.

Another interesting fact concerned with the diurnal variation in transmission is the fact first recorded by Marconi in his early transatlantic experiments. When the line of sunrise or sunset is between the two stations transmission is almost impossible, according to Marconi's results. It seems as though the twilight line acts as either a reflector or absorber of the radio waves.

Seasonal Variation in Signal Strength.—The strength of received signals varies also with the seasons, and in 1912, an investigation of this effect was made by L. W. Austin,¹ signals being received at Washington, D. C., from the radio stations in the Philadelphia and Norfolk Navy Yards. The results obtained are shown in Fig. 13.

The reason for this seasonal variation of signal strength is ordinarily considered as being due to the absorption of the waves by vegetation, thus causing a marked decrease in intensity during the summer months. This seems to be a reasonable conclusion, in view of the fact that trees have been successfully used as antennæ, thus demonstrating their energy-absorbing qualities. It was found that rainfall had no appreciable effect of the signal intensity.

Amount of Power Sent Out and Received.—Hertz showed that the electric and magnetic forces in the radiated wave varied inversely as the distance from a small Hertzian oscillator. The same relation is true for an ordinary grounded antennæ if the distance assumed does not exceed a few hundred miles.² The energy thus decreases inversely as the square of the distance, while the amplitude varies inversely as the distance. (See dotted curve shown in Fig. 12.)

¹ L. W. Austin "Seasonal Variation in the Strength of Radiotelegraphic Signals." Proc. Institute of Radio Engineers, June, 1915.

² See Chapter IX, page 707.

Duddell and Taylor¹ were the first to investigate the decrease of field as the distance from the transmitter increases, and a few of their results are given in the following table; the transmission was over land, but it is likely that for such short distances as were used in their tests, the values indicate accurately what might be expected over water also.

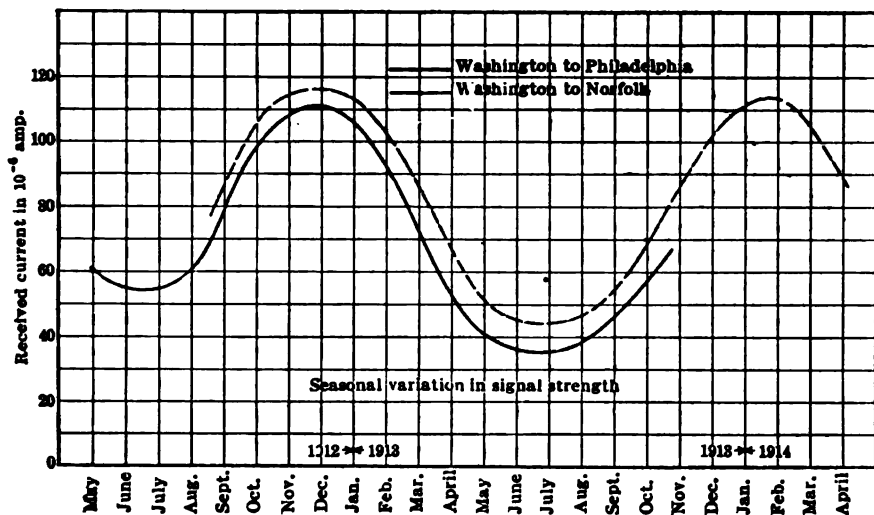

Fig. 13.—Variation of radio transmission occurring with seasonal frequency.

CURRENT IN THE RECEIVING ANTENNA WHEN THE DISTANCE BETWEEN THE TUNED TRANSMITTER AND RECEIVER IS VARIED. HEIGHT OF RECEIVING ANTENNA, 56 FT. HEIGHT OF TRANSMITTING ANTENNA, 42 FT.

Distance in Feet between Antennas.	CURRENTS IN ANTENNAE.		Approximate Wave Length.
	Transmitter Amperes (eff).	Receiver Micro-Amperes (eff).	
100	0.501	12320	400 ft.
200	0.507	6435	
300	0.558	4548	
400	0.541	3108	
1260	0.541	715	
2420	0.506	283.5	
3700	0.517	105	
4600	0.558	96.5	
6220	0.563	69.5	

¹ "Wireless Telegraph Measurements," by W. Duddell and J. E. Taylor, Journal Inst. Elec. Eng. Lond., 1905, vol. 35, p. 321. The receiving antenna had an effective resistance of about 60 ohms. Later tests over water showed that for distance up to 50 miles or more the current in the receiving antenna varied inversely as the distance.

From these figures it is readily seen how small the received power is compared to the power input to the transmitting antenna circuit.

The experiments of Austin, previously described, resulted in the empiric formula given on page 196, which holds approximately for distances up to 1000 miles. For the smallest distance considered, viz., 22 miles between the stations, using a 1000-meter wave, the following values were noted:

Miles between Stations.	Sending Station.	Receiving Station.	Wave Length Meters.	ANTENNAE CURRENT.	
				Sending Station Amperes.	Receiving Station Micro-Amperes.
22	U. S. S. Birmingham	Brant Rock	1000	33	10,500
22	U. S. S. Salem	Brant Rock	1000	27	11,000
22	U. S. S. Birmingham	Brant Rock	3750	27	3,200
22	U. S. S. Salem	Brant Rock	3750	24	4,100

A mathematical analysis of the Austin formula expressing the relation between the transmitting and receiving antennæ currents shows that in so far as transmission alone is considered under given conditions, there exists a best value of wave length to be used for any given distance between the stations. This best wave length is:

$$\lambda = \frac{(.0015)^2 d^2}{4},$$

where d is the distance between the stations in kilometers.

The following table gives the best wave lengths for various values of d as derived from the above formula:¹

d in kilometers.....	700	1000	1500	2000	3000	4000	5000
λ in meters.....	275	562	1260	2250	5070	9000	14,050

For a distance of 22 miles, wave lengths of 1000 and 3750 meters were far greater than the best value for this distance, as indicated by the very much diminished antenna currents at the receiver when the wave length was increased from 1000 to 3750 meters.

“Freak” Transmission.—The ideas presented in this and following chapter regarding the power used in radio communication represent average conditions. It may be that communication between two stations normally perfect, is cut off completely for several hours, as though a screen of some kind had been put between the two stations. It often

¹ It is to be noted, however, that these values do not check very well with those given on page 187, which are more nearly the actual values used in practice.

happens that a station on an island cannot communicate with a ship near the opposite shore, but that if the ship moves away perhaps 100 miles, the intervening land of the island offers no appreciable obstruction. This is indicated in Fig. 14. Illustrating another kind of freak transmission

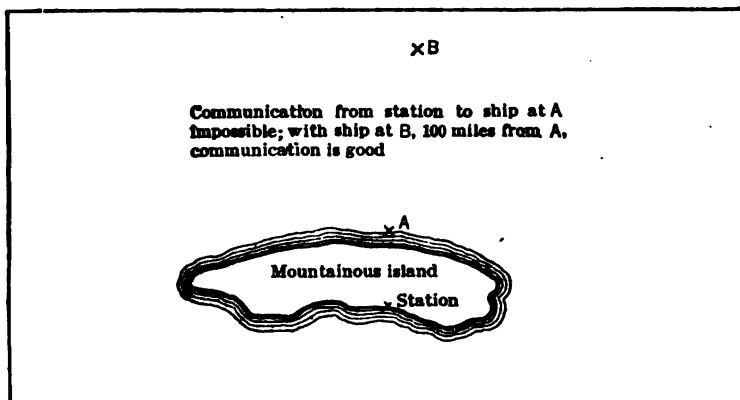

FIG 14.—A peculiar effect often observed in radio communication, giving rise to the idea of radio "shadows."

there is apparently substantial evidence that a low-power station (10 kw.) may sometimes give perfectly good signals to a ship 8000 miles away. Such freak transmission is more likely to occur with short waves than with long ones.

It is to be noted, when discussing the amount of power required for radio transmission, that, due to absorption, reflection, and refraction of the electromagnetic waves, the question is almost as indeterminate as—how far can a man shout?—over a quiet lake in the evening a man's voice may "carry" two or three miles; the same voice would carry about 500 feet on a city street, and in a busy shipyard the shout would be heard probably not more than 100 feet. Atmospheric disturbances make the range of a radio station almost as indeterminate.

CHAPTER IV

LAWS OF OSCILLATING CIRCUITS

Discharge of a Condenser through an Inductance and Resistance in Series.—Practically all radio sets which send out damped (or discontinuous) waves generate the high-frequency currents required by charging up a condenser from a suitable source of power, then letting this condenser discharge through an inductance in series with a spark gap. In general the oscillatory power so generated is transferred by coupling of some kind to another circuit from which it is radiated. The investigation of the form of oscillatory current in these coupled circuits will be taken up later in this chapter, we shall first investigate the discharge of a condenser in the single circuit.

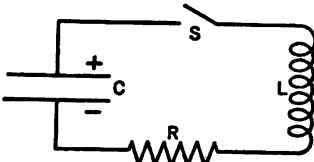

FIG. 1.—The charged condenser C will discharge through L and R connected to the circuit consisting of L and R in series when the switch S is closed.

In Fig. 1 is shown the circuit; the condenser C charged to voltage E is to be discharged through L and R in series when the switch S is closed.

The switch is not used in the actual radio circuit, a spark gap performing its function, but the resistance of the spark gap somewhat complicates the analysis so that its action is deferred until a later paragraph.

It will be supposed at first that the condenser has no leakage; the equation of reactions of the circuit after the switch is closed is,

$$L \frac{di}{dt} + Ri + v = 0,$$

v being the voltage across the condenser at any instant. Then

$$L \frac{d^2i}{dt^2} + R \frac{di}{dt} + \frac{dv}{dt} = 0.$$

But we know that

$$i = C \frac{dv}{dt}$$

so we have

$$L \frac{d^2i}{dt^2} + R \frac{di}{dt} + \frac{i}{C} = 0,$$

or

$$\frac{d^2i}{dt^2} + \frac{R}{L} \frac{di}{dt} + \frac{i}{LC} = 0. \quad \dots \dots \dots (1)$$

The solution of a differential equation of this kind is obtained by an "intelligent guess." It is evident that i must be a function of t and furthermore that this function must be of such a form that the second derivative of the function plus the first derivative multiplied by $\frac{R}{L}$ plus the function itself multiplied by $\frac{1}{LC}$ must add up to zero. By trial we find that if the current is of the form

$$i = A e^{mt}$$

Eq. (1) will probably be satisfied. Using this function we have

$$\frac{di}{dt} = mA e^{mt},$$

and

$$\frac{d^2i}{dt^2} = m^2 A e^{mt}.$$

Substituting these values in Eq. (1), we get

$$A e^{mt} \left(m^2 + \frac{R}{L} m + \frac{1}{LC} \right) = 0. \quad \dots \quad (1a)$$

As no useful solution is obtained by putting $A = 0$, we use the condition

$$m^2 + \frac{R}{L} m + \frac{1}{LC} = 0.$$

There are two roots to this equation either of which will satisfy it. As Eq. (1) involves the second derivative of i we know there must be two independent solutions for i and these two values of m which we call m_1 and m_2 , permit the two required solutions being written. The complete solution of Eq. (1) is the sum of the two particular solutions, so we write as the complete solution

$$i = A_1 e^{m_1 t} + A_2 e^{m_2 t}, \quad \dots \quad (2)$$

where

$$m = -\frac{R}{2L} \pm \sqrt{\frac{R^2}{4L^2} - \frac{1}{LC}} = -\alpha \pm \beta$$

So we have

$$i = e^{-\alpha t} (A_1 e^{\beta t} + A_2 e^{-\beta t}) \quad \dots \quad (3)$$

As initial conditions we have, at the instant the switch is closed ($t=0$), $i=0$, so from (3)

$$0 = A_1 + A_2. \quad \dots \quad (4)$$

Also if

$$i = 0, \quad Ri = 0, \quad \text{so} \quad \left(\frac{di}{dt} \right)_{t=0} = -\frac{E}{L},$$

which when substituted in Eq. (3) after differentiation gives

$$-\frac{E}{L} = (\beta - \alpha)A_1 - (\beta + \alpha)A_2. \quad \dots \quad (5)$$

Solving (4) and (5) for A_1 and A_2 we get

$$A_1 = -\frac{E}{2\beta L} \text{ and } A_2 = +\frac{E}{2\beta L},$$

which values substituted in Eq. (3) give

$$i = -\frac{E}{2\beta L} \epsilon^{-\alpha t} (\epsilon^{\beta t} - \epsilon^{-\beta t}), \quad \dots \quad (6)$$

in which

$$\alpha = \frac{R}{2L} \text{ and } \beta = \sqrt{\alpha^2 - \frac{1}{LC}}.$$

The quantity α is always real, which means that the amplitude of the current continually decreases with increase of time. The quantity $(\epsilon^{\beta t} - \epsilon^{-\beta t})$, which determines the form of the current, while it is decaying, depends for its value on the quantity β ; this may be either real or imaginary, according as α^2 is greater or less than $\frac{1}{LC}$. The form of the current will be analyzed for the three conditions—

$$\alpha^2 > \frac{1}{LC}, \quad \alpha^2 = \frac{1}{LC}, \quad \alpha^2 < \frac{1}{LC}.$$

$$\text{CASE 1. } \alpha^2 > \frac{1}{LC}.$$

In this case β is a real quantity so we have

$$i = -\frac{E}{\beta L} \epsilon^{-\alpha t} \left(\frac{\epsilon^{\beta t} - \epsilon^{-\beta t}}{2} \right) = -\frac{E}{\beta L} \epsilon^{-\alpha t} \sinh \beta t \quad \dots \quad (7)$$

The negative sign indicates that the effect of the current is to decrease E , i.e., to release the charge on the condenser—as to whether or not current is actually positive or negative depends upon the polarity of charge on the condenser assumed positive.

The form of current in this case is shown in Fig. 2; the lines properly marked give the two terms $\epsilon^{-\alpha t}$ and $\sinh \beta t$. The figure is drawn to scale for $E=100$ volts, $C=10\mu\text{f}$, $L=.20$ henry, and $R=500$ ohms. By calculation we find $\alpha=1250$ and $\beta=1030$.

The maximum current is reached at a time calculated from putting the first derivative of Eq. 7 equal to zero.

This results in the equation

$$e^{2\beta t} = -\frac{\beta + \alpha}{\beta - \alpha}$$

OR

$$t = \frac{1}{2\beta} \log_e \frac{\alpha + \beta}{\alpha - \beta} \dots \dots \dots (8)$$

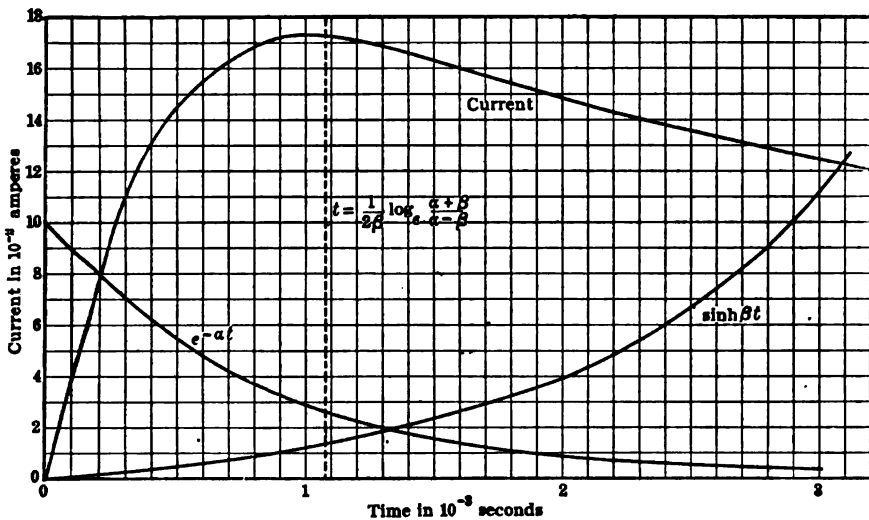

Fig. 2.—Calculated discharge current when the R of Fig. 1 is too high for oscillatory discharge.

Fig 3 shows two oscillograms of a condenser discharge current for the case just analyzed.

CASE 2. $\alpha^2 = \frac{1}{LC}$.

In this case we have $\beta=0$. We write the current in the form,

$$i = -\frac{E}{2L} e^{-\alpha t} \left(\frac{e^{\beta t} - e^{-\beta t}}{\beta} \right),$$

the value of the expression in the parenthesis being indeterminate. We evaluate it by differentiation and get,

$$\left(\frac{\frac{d}{d\beta}(e^{\beta t} - e^{-\beta t})}{\frac{d}{d\beta}(\beta)} \right)_{\beta=0} = \left(\frac{t(e^{\beta t} + e^{-\beta t})}{1} \right)_{\beta=0} = 2t.$$

Hence in this case the equation for the discharge current is,

$$i = -\frac{Et}{L}e^{-\alpha t} \dots \dots \dots (9)$$

The graph of such a discharge current is shown in Fig. 4 for $E=100$ volts, $C=10 \mu f$, $L=.20$ henry, and $R=282.3$ ohms.

The time at which maximum current occurs is obtained as outlined for the previous case and yields the condition that,

$$t = \frac{1}{\alpha} \dots \dots \dots (10)$$

For the conditions given this time is .001416 second after closing the switch.



FIG. 3.—Oscillograms of discharges similar to Fig. 2.

Fig. 5 shows an oscillogram of such a critically damped circuit; the time scale on the lower part of the film permits the validity of Eq. (10) to be checked.

CASE 3. $\alpha^2 < \frac{1}{LC}$.

In this case β becomes the square root of a negative quantity, and we write it

$$\beta = \sqrt{\alpha^2 - \frac{1}{LC}} = \sqrt{(-1)\left(\frac{1}{LC} - \alpha^2\right)} = j\sqrt{\frac{1}{LC} - \alpha^2} = j\omega.$$

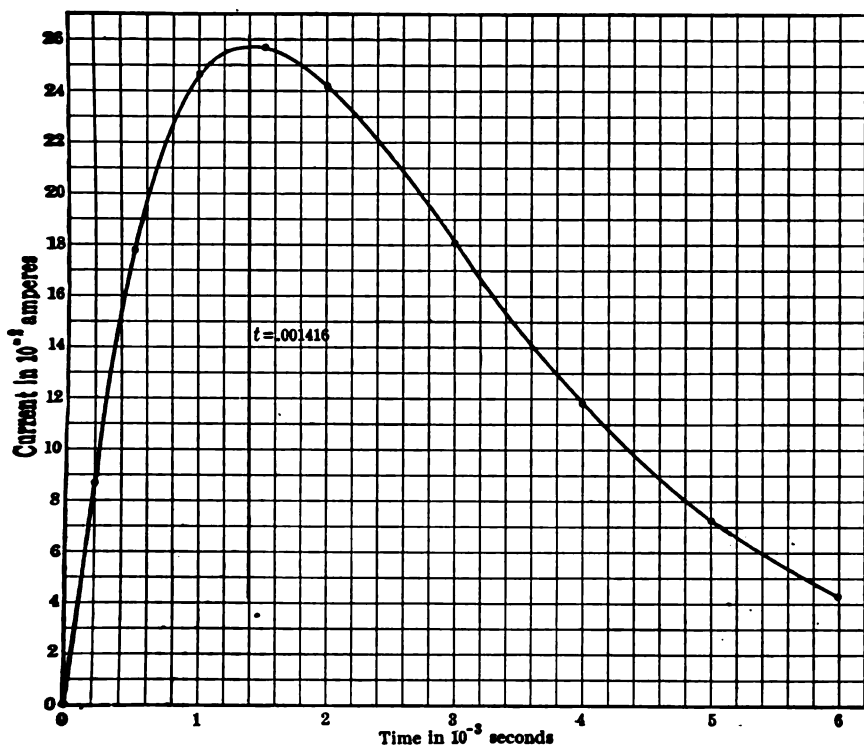

FIG. 4.—Discharge in a circuit in which R has the minimum possible value without permitting oscillatory discharge.

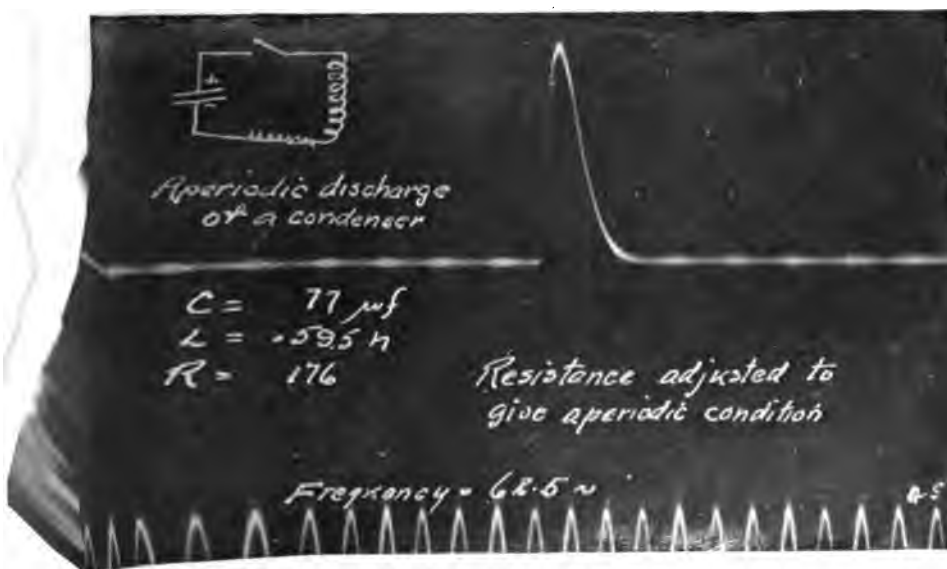

FIG. 5.—Oscilloscope of current for conditions assumed in Fig. 4.

Then from Eq. (6)

$$i = -\frac{E}{2j\omega L} \epsilon^{-\alpha t} (\epsilon^{j\omega t} - \epsilon^{-j\omega t}) = -\frac{E}{\omega L} \epsilon^{-\alpha t} \left(\frac{\epsilon^{j\omega t} - \epsilon^{-j\omega t}}{2j} \right)$$

$$= -\frac{E}{\omega L} \epsilon^{-\alpha t} \sin \omega t \dots \dots \dots (11)$$

The current in this case is oscillatory, its frequency being fixed by the value of ω ; the term $\epsilon^{-\alpha t}$ represents the decay of the current, and the theoretical maximum value of the current is given by $\frac{E}{\omega L}$.

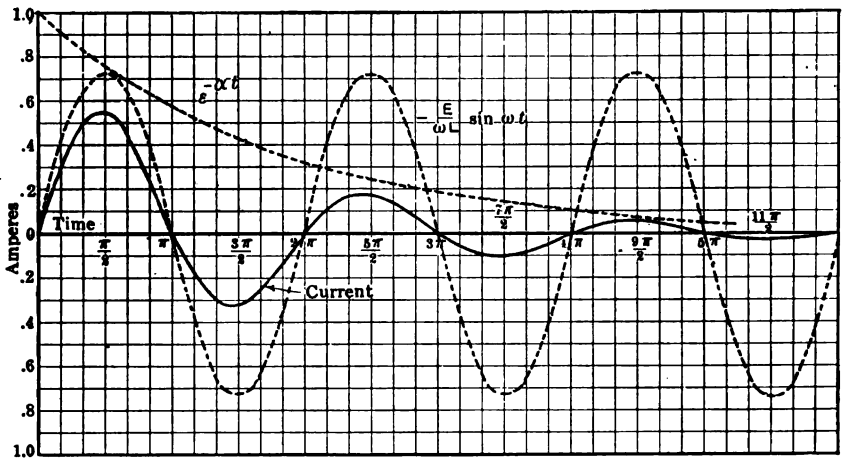

FIG. 6.—Value of R of Fig. 1 reduced sufficiently to permit the ordinary oscillatory discharge, giving a “damped sine wave.”

In Fig. 6 are plotted, in dotted lines, each of the terms of Eq. (11) for a circuit of $E=100$ volts, $C=10 \mu f$, $L=.20$ henry, and $R=50$ ohms.

We have
$$\alpha = \frac{R}{2L} = \frac{50}{2 \times .20} = 125$$

$$\omega = \sqrt{\frac{1}{LC} - \alpha^2} = \sqrt{\frac{10^6}{.2 \times 10} - 125^2} = 695.$$

But $\omega = 2\pi f$, hence

$$f = \frac{695}{2\pi} = 110.5 \text{ cycles per second.}$$

The actual equation for the current is then,

$$i = -\frac{100}{695 \times .2} \epsilon^{-125t} (2\pi 110.5 t).$$

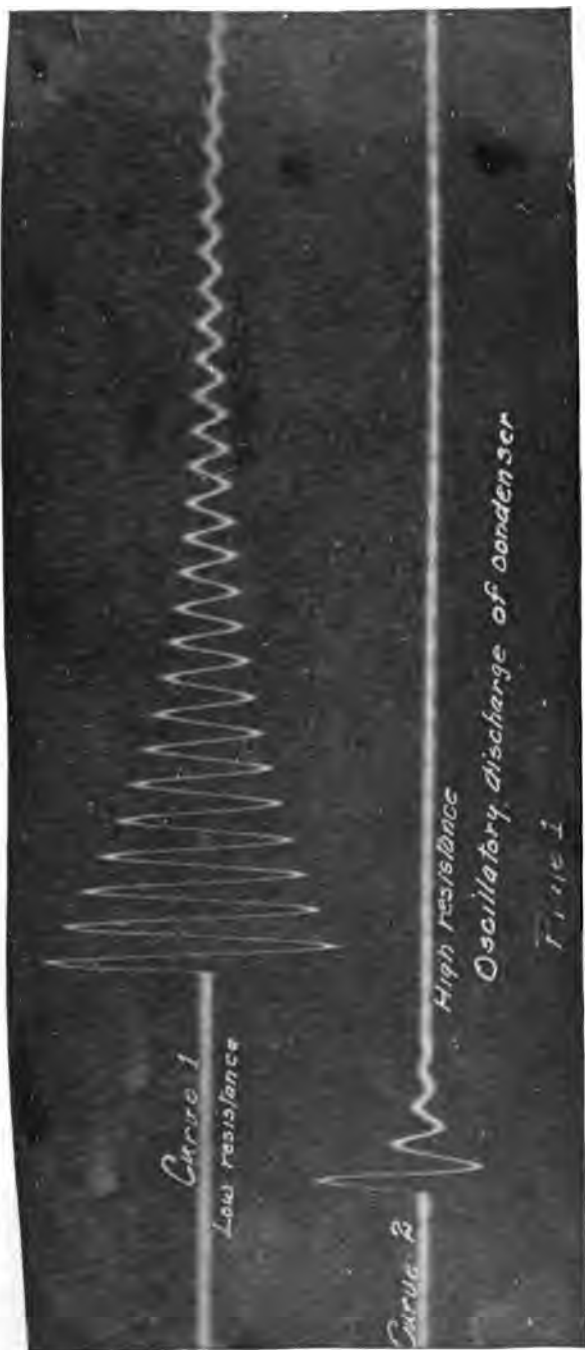

FIG. 7.—Oscillograms of oscillatory discharge for two values of resistance.

This curve is shown in the full lines of Fig. 6. It is generally called a "damped sine wave," the term ϵ^{-at} giving the damping. In Fig. 7 is shown the oscillogram of a damped sine wave showing how the actual current is of the form indicated by Eq. (11) for two values of resistance.

Effect of Condenser Leakage.—In case the condenser has appreciable

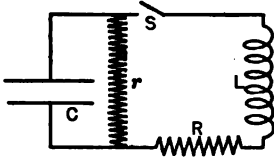

FIG. 8.—Oscillatory circuit in which the condenser is "leaky."

leakage the solution takes a slightly different form. The circuit is now as shown in Fig. 8; the energy stored in the condenser when the switch is closed is partially consumed in the series resistance R , partially consumed in the leak resistance r , and the rest transformed into magnetic energy in the coil; then the magnetic energy in the coil is transformed back to electrostatic energy in the recharged

condenser, but during the transformation more of the energy is wasted in R and r .

The differential equation of the circuit becomes

$$L \frac{di}{dt} + Ri + v = 0$$

or

$$L \frac{d^2i}{dt^2} + R \frac{di}{dt} + \frac{dv}{dt} = 0.$$

We have $i_c = C \frac{dv}{dt}$, and $i_c = i + i_g$, where $i_g = vg$, g being equal to $\frac{1}{r}$.

Now, in magnitude, $v = L \frac{di}{dt} + Ri$, so that $i_g = gL \frac{di}{dt} + gRi$.

Substituting then $\frac{dv}{dt} = \frac{i_c}{C}$ and using the value of i_g just obtained, we get

$$LC \frac{d^2i}{dt^2} + (RC + gL) \frac{di}{dt} + (1 + gR)i = 0, \dots \dots (12)$$

which may be written $\frac{d^2i}{dt^2} + \left(\frac{R}{L} + \frac{g}{C}\right) \frac{di}{dt} + \left(\frac{1 + gR}{LC}\right) i = 0.$

This equation is similar in form to (1) and its solution is of exactly the same form. For this case, however, we have

$$\alpha = \frac{R}{2L} + \frac{g}{2C}, \dots \dots \dots (13)$$

and

$$\beta = \sqrt{\frac{1}{4} \left(\frac{R}{L} - \frac{g}{C}\right)^2 - \frac{1}{LC}} \dots \dots \dots (14)$$

The three cases considered in the previous section occur also for this circuit; the conclusions reached are the same, except where previously $\frac{R}{2L}$ determined the damping, we now have the quantity $\left(\frac{R}{2L} + \frac{g}{2C}\right)$.

The conditions for oscillations or no oscillations is affected by the condenser leakage in a manner not to be expected; with no leakage the non-oscillatory condition is reached when

$$\frac{R}{2L} = \frac{1}{\sqrt{LC}}$$

and for the leaky condenser the criterion is

$$\left(\frac{R}{2L} - \frac{g}{2C}\right) = \frac{1}{\sqrt{LC}} \quad \text{from (14)}$$

That is, a circuit which has sufficient series resistance to be critically damped may become oscillatory if sufficient leakage is introduced across the condenser.

For the circuit considered in the previous section the non-oscillatory condition was reached when R was adjusted for 282.3 ohms; we then had $\alpha = 707$. If we now shunt the condenser by a leak resistance of 1000 ohms we have

$$\alpha = \frac{282.3}{2 \times .2} + \frac{10^5}{10^3} = 807;$$

that is, greater than before, but we now have an oscillatory circuit because $\left(\frac{R}{2L} - \frac{g}{2C}\right)$ is less than $\frac{1}{\sqrt{LC}}$. Thus we have the unexpected phenomenon of increased damping changing a non-oscillatory circuit to an oscillatory one. Fig. 9 shows the three currents for the circuit with leaky condenser, as in Fig. 8.

The frequency of the free oscillation is lowered by the series resistance of the circuit, but it is raised by the effect of shunt resistance until this shunt resistance reaches the value such that $\frac{R}{L} = \frac{g}{C}$. If the shunt, or leak resistance, is made still less the frequency will again decrease; from this it is seen that the effect of a leak resistance (with no series resistance) is to increase the damping and increase the period, just as is the case for a series resistance above, but that when both are present the damping is increased by an amount depending on the sum of the series resistance and leak resistance, but that the effect of these two on the period is subtractive, and that a certain relation between them suffices for complete neutralization, so that the natural period is the same as it would be if the circuit had no dissipative reactions at all.

Frequency—Wave Length.—In the previous paragraph the frequency of an oscillatory discharge was shown to be fixed by the damping, inductance, and capacity. The effect of the damping constants in the frequency is, in ordinary radio circuits, so small that it can be neglected without appreciable error, so that this formula for frequency of an oscillatory circuit becomes

$$\omega = 2\pi f = \frac{1}{\sqrt{LC}}$$

or

$$f = \frac{1}{2\pi\sqrt{LC}} \dots \dots \dots (15)$$

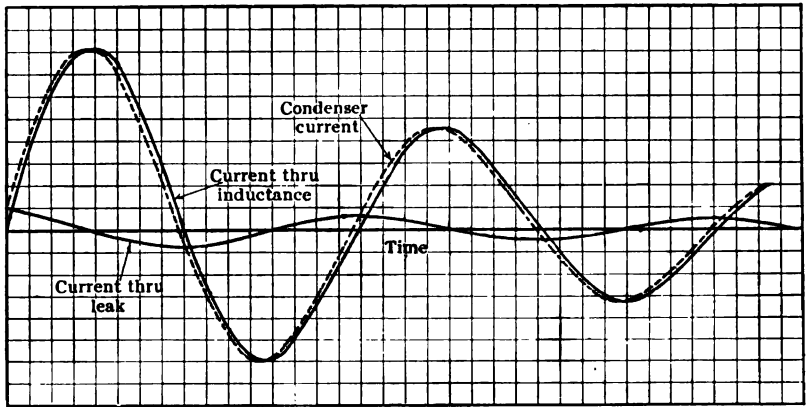

FIG. 9.—Calculated currents for circuit depicted in Fig. 8.

In the formula f is in cycles per second, L in henries, and C in farads. Now in radio circuits the values of L and C are more generally measured in micro-units and the formula becomes,

$$f = \frac{10^6}{2\pi\sqrt{LC}} \dots \dots \dots (16)$$

where L is in microhenries and C in microfarads.

It is more customary to use the term *wave length* in radio literature, instead of frequency. When an antenna is excited by an oscillatory current of frequency f it sends out over the earth's surface electromagnetic waves which travel out from the antenna with the velocity of light, i.e., 3×10^8 meters per second. In a wave phenomenon the frequency and wave length (always designated in radio by the symbol λ) are connected by the formula

$$f\lambda = V, \dots \dots \dots (17)$$

where V is the velocity of travel of the waves. We therefore find for the value of wave length of these electromagnetic radiations

$$\lambda = \frac{V}{f} = \frac{3 \times 10^8 \times 2\pi \sqrt{LC}}{10^6} = 1885 \sqrt{LC}. \quad \dots \quad (18)$$

In this formula λ is given in meters, L in microhenries, and C in microfarads.

Relation of Current and Voltage in Oscillatory Circuits.—The equation for the discharge of condenser for the ordinary condition (Case 3, p. 208, Eq. 11) is

$$i = -\frac{E}{\omega L} \epsilon^{-\alpha t} \sin \omega t,$$

in which

$$\alpha = \frac{R}{2L},$$

and we have said that in the ordinary radio circuit ω is approximately equal to

$$\frac{1}{\sqrt{LC}}.$$

Equation (11) therefore becomes,

$$i = -E \sqrt{\frac{C}{L}} \epsilon^{-\frac{Rt}{2L}} \sin \frac{t}{\sqrt{LC}}. \quad \dots \quad (19)$$

The maximum current occurs one-quarter of a cycle after closing the switch, nearly; the effect of the damping term $\epsilon^{-\frac{Rt}{2L}}$ is to make the current a maximum shortly before the quarter cycle interval. The value of this current, neglecting the small effect of the damping for one quarter cycle, is equal to $E \sqrt{\frac{C}{L}}$.

Now this could have been predicted from the consideration of energy in the circuit; before the switch is closed all the energy is in the condenser and is equal to $\frac{CE^2}{2}$. One quarter cycle after closing the switch the voltage across the condenser is zero, so that all the energy must be in the coil, hence we may put

$$\frac{CE^2}{2} = \frac{LI^2}{2},$$

or

$$I = E \sqrt{\frac{C}{L}},$$

as we had before.

In an oscillatory circuit there is a certain amount of energy oscillating back and forth from coil to condenser, and being wasted during the trans-

fer. The frequency of transfer will be the same no matter what the relative value of L and C , so long as their product is constant. It is sometimes desired to establish resonance in a circuit and keep the voltage low; in such a case a low value of L and correspondingly high value of C should be chosen. In radio-receiving circuits, however, it is generally desired to obtain as high a voltage as possible; this is done by using as low a value of C as possible (sometimes as low as 100 micro-microfarads) and a correspondingly high value of L .

Damping and Decrement.—In Eq. (19) the factor $e^{-\frac{Rt}{2L}}$ represents a logarithmic decrease in the amplitude of the current; the value of $\frac{R}{2L}$ is called the *damping coefficient* of the circuit. For the average radio circuit this coefficient is of the order of 1000 to 10,000, being greater the shorter the wave length of the set. The damping coefficient multiplied by the time of one cycle is called the *logarithmic decrement* or merely the *decrement* of the circuit.

If we write the values of successive maxima of current (maxima in the same direction) we shall have from Eq. (19), calling T the period of oscillation,

$$I_1 = -E\sqrt{\frac{C}{L}}e^{-\frac{R}{2L}\frac{T}{4}} = I_0e^{-\frac{R}{2L}\frac{T}{4}}$$

$$I_2 = I_0e^{-\frac{R}{2L}\left(\frac{T}{4}+T\right)} = I_1e^{-\frac{R}{2L}T}$$

$$I_3 = I_0e^{-\frac{R}{2L}\left(\frac{T}{4}+2T\right)} = I_2e^{-\frac{R}{2L}T}, \text{ etc.}$$

From these we get

$$\frac{I_1}{I_2} = \frac{I_2}{I_3} = \frac{I_3}{I_4} \text{ etc.} = e^{\frac{R}{2L}T} = e^{\delta},$$

where δ is the decrement of the circuit. As $T = \frac{1}{f}$ it is evident that

$$\delta = \frac{R}{2fL} \dots \dots \dots (20)$$

An ordinary radio set has a decrement about 0.1; the large stations may have a decrement as low as .02, while the upper limit for a transmitting station is 0.2, this being fixed legally as the maximum decrement a spark station is allowed. As is evident from Eq. (20), the decrement of a circuit depends directly upon the resistance of the circuit, this resistance being interpreted in the broadest sense as suggested on page 112. In transmitting stations the ground resistance of the antenna is likely to be very important in its effect on the decrement. The decrement meas-

ured from the upper curve of the film of Fig. 7 was .150, while that calculated from the constants of the circuit was .152.

In a continuous wave transmitting station the source of high-frequency power maintains a constant amplitude to the successive cycles and the station is said to have a zero decrement; in certain receiving circuits using a vacuum tube for receiver, the effective resistance of the circuit made to approach zero as nearly as desired, thus making the decrement of the receiving set approach zero. As explained in Chapter I, pp. 62-65, the decrement is the important factor in determining the selectivity of a receiving circuit, as it determines the sharpness of resonance.

Decrement Determined by Energy Waste per Cycle.—The decrement may be defined as the ratio of the energy dissipation per cycle to the energy transferred during the same interval of time. Neglecting the small change in value of maximum current during one cycle we have:

$$\text{Energy dissipated per cycle} = \frac{RI^2}{2f},$$

where I is the maximum value of current.

Suppose we consider the cycle to begin when I has maximum positive value and all the energy is in the coil, this energy being equal to $\frac{LI^2}{2}$.

Now during one cycle this energy flows from the coil to the condenser, back to the coil (when I goes through its values of opposite polarity) back to the condenser and then back to the coil. The energy makes two complete transfers through the circuit so that the amount of energy transfer during one cycle is

$$2 \times \frac{LI^2}{2} = LI^2.$$

Hence,

$$\frac{\text{Energy dissipated}}{\text{Energy transferred}} = \frac{\frac{RI^2}{2f}}{LI^2} = \frac{R}{2fL} = \delta.$$

If the above analysis were carried through rigorously (taking account of decrease of I during the cycle), it would be found that the above relation for δ is correct.

Current, Voltage, and Energy in a Damped Wave.—During the decay of a wave train the corresponding maximum values of electrostatic energy of the condenser and electro-magnetic energy of the coil remain practically equal; the voltage across the condenser goes through the same changes as does the current through the inductance. Using the relation between the voltage across the condenser and the current in the circuit

$$e_c = \int \frac{idt}{C},$$

we get from Eq. (11) the approximate relation

$$e_c = E e^{-\alpha t} \cos \omega t.$$

At any instant, therefore, the energy in the condenser is

$$w_c = \frac{CE^2}{2} e^{-2\alpha t} \cos^2 \omega t.$$

And we have for the energy in the coil,

$$w_L = \frac{LI_0^2}{2} e^{-2\alpha t} \sin^2 \omega t.$$

If we substitute for I_0 its value determined above $\left(E \sqrt{\frac{C}{L}} \right)$ and then add we get

$$w_c + w_L = w = \frac{CE^2}{2} e^{-2\alpha t} \dots \dots \dots (21)$$

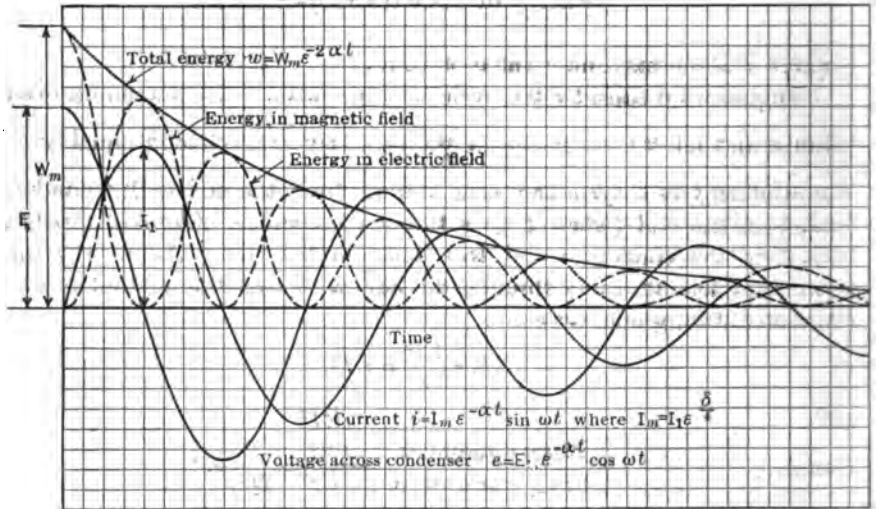

FIG. 10.—Conventional energy curve representation in an oscillatory circuit.

From the equation we see that the original energy stored in the condenser, $\frac{CE^2}{2}$, undergoes a logarithmic decay, with damping coefficient twice that of the current.

The curves of current, voltage, and energy are plotted in Fig. 10; the total energy is obtained by adding the corresponding instantaneous values of the magnetic and electric energy. In reality the current and voltage are not exactly 90° out of phase, due to the effect of the resistance of the circuit so that the addition of the two components of energy does not give

the smooth exponential curve shown in Fig. 10, but a wavy exponential curve as indicated in Fig. 11. Here a decrement of 0.3 has been assumed, giving a power factor of $\frac{3}{\pi} = .0955$; the phase difference of E and I is therefore 84.5° . The energy for the electric and magnetic fields no longer adds to give the smooth energy curve of Fig. 10, but indicates that the dissipation of energy from the system is more rapid at certain parts of the cycle than at others. When all the dissipated energy appears in the form of heat in the series resistance (as supposed for Fig. 11), the maximum rate of dissipation corresponds with the time of maximum current as it should; when the current is zero there is no energy being dissipated.

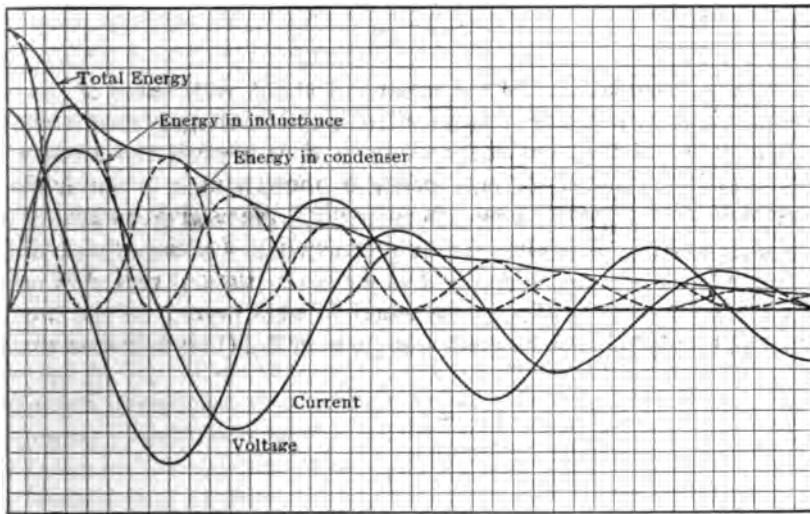

FIG. 11.—Actual energy curve for an ordinary oscillatory circuit.

In case the condenser used in the oscillatory circuit is a leaky one, with leak conductance, g , the energy dissipated while an oscillatory current is flowing is used up partly in the series resistance of the circuit and partly in the conductance across the circuit. The rate of energy dissipation in the series resistance is i^2R and the rate of energy dissipation in the leak is e_c^2g . It will be noticed that these two power losses do not have their maxima at the same instant; when e_c is a maximum i is practically zero.

If the series resistance and shunt resistance are properly proportioned the power dissipated in each will be the same; the proper ratio is obtained by putting

$$I^2R = E^2g = \frac{E^2}{r}$$

Now we have,

$$I^2 = \omega^2 C^2 E^2,$$

and so,

$$\omega^2 C^2 E^2 R = \frac{E^2}{r},$$

from which

$$R = \frac{1}{r} \frac{1}{\omega^2 C^2}.$$

The relation may also be expressed

$$R = \frac{1}{r} \frac{L}{C},$$

or we may also put it in the form,

$$\frac{R}{L} = \frac{g}{C}.$$

Such a proportionality¹ in the series and shunt resistances of the circuit will result in a power consumption in the oscillating circuit which does not fluctuate throughout the cycle as it does when the relation is not maintained. Hence the energy decay in the circuit is not a wavy line as given in Fig. 11, but a smooth logarithmic curve as given in Fig. 10.

It is interesting to note that this proportionality of series and shunt resistances is the same as is required to make the natural period of oscillation the same as if no dissipative reactions were present in the circuit. The natural period of such a circuit was given in Eq. (14); it is seen that if

$$\frac{R}{L} = \frac{g}{C},$$

then

$$f = \frac{1}{2\pi\sqrt{LC}}.$$

Oscillatory Discharge through a Spark Gap.—If the oscillating circuit contains a spark gap the current is not of the form indicated by Eq. (11), because of the influence of the gap; as pointed out on page 139 the resistance of a given spark gap is not constant but depends upon the current flowing through it. The resistance of the gap is smaller the higher the amplitude of current through it, as is more or less evident from the appearance of a spark. The greater the current through the gap the larger is the cross-section of the hot, ionized gas conducting the current, and the more intensely is it ionized, both of these effects lowering the gap resistance.

¹The same proportionality has a peculiar significance when applied to long conductors, such as telephone lines. It was first pointed out by O. Heaviside that such relation between the various constants of a line gives so-called "distortionless" transmission of speech waves.

When a charged condenser discharges through the circuit represented in Fig. 12, the equation of discharge is

$$L \frac{di}{dt} + (R + R_s)i + v = 0, \dots \dots \dots (22)$$

where R_s is the resistance of the spark gap. If R_s can be written as a simple function of the current this equation can be solved, but it is quite likely that the function is an intricate one, depending not only on the magnitude of current, but on the frequency of the oscillations.

The value of R_s undoubtedly varies a great deal throughout the cycle, but these variations can have much less effect on the magnitude and shape of the current than might be supposed. The resistance reaction is the only reaction limiting the value of the current of fundamental frequency (approximately $\frac{1}{2\pi\sqrt{LC}}$) but any upper harmonics which the cyclically varying resistance might tend to produce in the circuit would be opposed by a reactance several hundred times as great as the resistance, because the inductance and capacity reactions balance only for the fundamental frequency. Hence the cyclical change in resistance may be neglected in so far as it affects the solution of the oscillatory current defined by Eq. (22).

By means of a Braun tube oscillograph photographs have been taken of the oscillations in such a circuit as that of Fig. 12, and the commonly accepted interpretation of these photographs is that the decay of current is linear with respect to time instead of exponential, as given in Eq. (11).

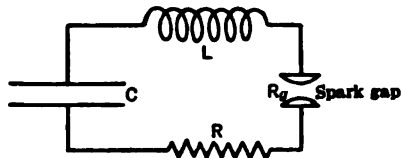

FIG. 12.—Oscillatory circuit in which a spark gap is used.

On the assumption that the resistance of the circuit did not affect the frequency and using the experimental data given by Zenneck, J. S. Stone has shown that if the gap resistance is written

$$R_s = \frac{2BL}{A - Bt}$$

A and B being constants, and the other resistance in the circuit is negligible the solution of Eq. (22) becomes,

$$i = -E\sqrt{\frac{C}{L}} \left(1 - \frac{R_0 t}{2L}\right) \sin \frac{t}{\sqrt{LC}}, \dots \dots \dots (23)$$

where R_0 = initial resistance of spark gap. Although not so stated in Stone's paper, this value R_0 must be approximately this resistance at the

first current maximum. The other symbols have their ordinary meanings. The solution is really of little importance in radio work, because in no case is the spark gap the controlling factor in a radiating circuit. Such a circuit would use up practically all of its stored energy in heating the spark gap, so it is practice to remove the high-frequency power from the spark-gap circuit as quickly as possible and let it radiate from a circuit which has no gap. Even when the energy is in the spark-gap circuit the resistance of the gap is small compared to the *resistance introduced into this circuit by the coupled antenna circuit* as indicated by Eq. 84, p. 91.

The current of Eq. (23) is different from that of Eq. (11) in that the successive maxima have a constant *difference*, whereas those of Eq. (11) have a constant *ratio*. Thus the linear damping gives a wave train (group of oscillations) which has a definite end, whereas the logarithmic decrement never actually reduces the current to zero.

Number of Waves in a Train.—When an oscillatory current is expressible by Eq. (11) it is evident that there must be an infinite number of cycles per discharge of the condenser (or per wave train); the damping factor $\epsilon^{-\frac{Rt}{2L}}$ makes the current approach zero value, but theoretically it never reaches the zero value. It is customary in radio practice to say that a wave train has ended when the current amplitude has fallen to 1 per cent of its initial amplitude; this means of course that the energy remaining in the circuit is only (1 per cent)² = .0001 of its initial value.

The successive maxima of current are related by the equation

$$I_n = I_1 \epsilon^{-(n-1)\delta}$$

and if

$$\frac{I_1}{I_n} = 100,$$

we have

$$\log_e 100 = (n-1)\delta,$$

or

$$n = \frac{4.6 + \delta}{\delta} \quad (24)$$

Thus if the decrement of an antenna is .05 there will be $\frac{4.6 + .05}{.05} = 93$ complete cycles before the energy has been sufficiently dissipated to reduce the current to 1 per cent of its initial value.

In the case of a linearly damped wave train the number of waves is very few, principally because if the gap resistance is so large that the rest of the circuit resistance is negligible (a necessary assumption for linear decrement) the decrement is of such a high value that the wave train cannot have more than perhaps five to ten cycles before it is completely finished:

It is interesting to note that at the end of a logarithmically decaying wave train the condenser in the circuit is completely discharged, while the circuit with linear decrement may leave a considerable charge in the condenser at the end of a wave train. When the resistance of the spark gap becomes too high, towards the end of the train when the current is small, the gap opens (probably at a time when the current is zero), leaving the condenser charged to some appreciable voltage.

Effective Value of Current in a Damped Wave Train.—The effective value of a damped sine wave may be obtained by integration of the heating effect of the current

$$I^2 = \frac{1}{T} \int_0^T (I_0 e^{-\alpha t} \sin \omega t)^2 dt.$$

Evidently the value of this integral will vary with the length of time over which the integration is extended, and is to this extent indeterminate in value. As in practice one wave train follows another in rapid succession we are really interested in an integral of the form,

$$I^2 = N \int_0^\infty (I_0 e^{-\alpha t} \sin \omega t)^2 dt = N I_0^2 \int_0^\infty e^{-2\alpha t} \sin^2 \omega t dt,$$

where N is the number of discharges per second.

This may be integrated by standard methods, which yield the solution,

$$I^2 = N I_0^2 \frac{\omega^2}{4\alpha(\alpha^2 + \omega^2)}.$$

Now we have
and

$$\omega = 2\pi f;$$

$$\alpha = f\delta,$$

so

$$\frac{\omega^2}{\alpha^2 + \omega^2} = \frac{(2\pi f)^2}{(f\delta)^2 + (2\pi f)^2} = \frac{1}{1 + \left(\frac{\delta}{2\pi}\right)^2}.$$

So

$$I^2 = \frac{N I_0^2}{4f\delta} \frac{1}{1 + \left(\frac{\delta}{2\pi}\right)^2}.$$

Now, $\left(\frac{\delta}{2\pi}\right)^2$ is, for the most radio circuits, negligible compared to unity. If we write in place of the theoretical value of current I_0^2 , its equal, $E^2 \frac{C}{L}$, and put $\frac{1}{1 + \left(\frac{\delta}{2\pi}\right)^2} = 1$, we get the expression,

$$I^2 = \frac{NE^2C}{4f\delta L} = \frac{NE^2C}{2R}.$$

or

$$I = E\sqrt{\frac{NC}{2R}} \dots \dots \dots (25)$$

We could have obtained the same result by noticing that all the energy stored in the condenser is transformed in heat or radiation by the oscillatory current. So we can put

$$N \frac{CE^2}{2} = I^2R,$$

or

$$I = E\sqrt{\frac{NC}{2R}}$$

as before.

The value of I is what a hot-wire meter in the circuit would indicate; the maximum instantaneous value of the current directly after the discharge starts may be a hundred times as great as the value given by Eq. (25).

Effect of Neighboring Circuits on Frequency and Damp'ng.—If another closed circuit of inductance and resistance is so situated that currents are induced in it by the oscillatory current of the first circuit, the damping of the first circuit is increased and the frequency is increased because of the decrease in inductance. The changes in L and R due to the extra circuit are calculable from Eqs. (73) and (74) of Chap. I; the effect on the decrement is increased not only by the increase in R , but also by the decrease in L .

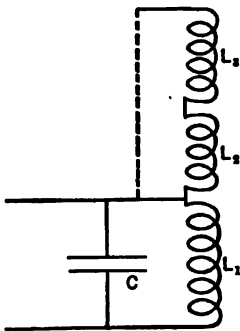

FIG. 13.—In many radio sets part of the multi-sectional transmitting inductance $L_1-L_2-L_3$ is short circuited when but one part (e.g., L_1) is being actually used for transmitting.

In spite of these effects it is sometimes the practice to intentionally short circuit part of the coils in a transmitting set. Thus in Fig. 13 is shown a diagram of such a scheme; the inductance is made in three sections, connected electrically, and also magnetically. When being used for short wave lengths (high frequency) only one section of the inductance, L_1 is connected in series with the condenser, the others being used when longer wave lengths are desired. Now with the connection as shown, the inductance acts like an autotransformer, generating very high voltages at the open end of the coil. This high voltage may cause excessive losses due to both corona and dielectric losses in the insulating supports. Also the voltage generated at the free end may be high enough to break down the

coil insulation. To obviate these difficulties the parts L_2 and L_3 are short circuited, as shown by the dotted line, thus increasing the decrement of the L_1C circuit, as noted above. The decrement may in certain

cases be even less with L_2 and L_3 short circuited, than it would be if they were not short circuited.

Effect of a Neighboring Tuned Circuit on an Oscillatory Discharge.—When an oscillatory discharge takes place in a circuit to which is coupled, either by mutual capacity or mutual inductance, another circuit consisting of inductance and capacity, the form of the current is no longer a simple logarithmic decay, but is much more complicated, the exact form depending upon the coefficient of coupling between the two circuits, the relation between the natural frequencies of the two circuits, the resistances of each, and the type of spark gap used in the discharge circuit.

Before anyone takes up the study of the coupled circuits he should make himself a simple piece of apparatus, which offers the same peculiarities to motion as coupled circuits do to current. This apparatus is shown in Fig.

14; it consists of a board about 10 cm. by 30 cm. with two upright posts about 30 cm. high fastened at the ends. Across the tops of the two posts is fastened a string and from this string are suspended two pendulums, *A* and *B*, the lengths of which are readily adjustable and which can be slid along the supporting string so that their points of support, *a* and *b*, can be separated or brought together.

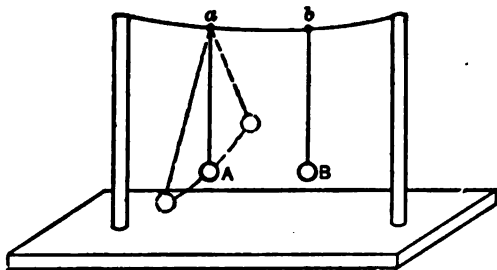

FIG. 14.—Coupled pendulum model.

of which are readily adjustable and which can be slid along the supporting string so that their points of support, *a* and *b*, can be separated or brought together.

This simple piece of apparatus is the mechanical analogue of two resonant electrical circuits; each of the pendulums has a natural period of its own and as it swings it tends to make the other pendulum oscillate also.

Suppose that bob *A* is pulled to one side, bob *B* being stationary; as *A* swings sidewise it, of course, pulls its point of support, *a*, sidewise and thus pulls point *b* sidewise with it. This motion of point *b* will gradually set bob *B* into motion, as the amplitude of motion of *B* increases that of *A* decreases and after perhaps twenty or thirty complete vibrations of *A* its motion will have been reduced to practically zero and that of *B* will have increased to a maximum, practically the same as the original amplitude of *A*. This remark holds good only if the lengths and weights of the two pendulums are the same.

Qualitative Analysis of the Pendulum Experiment.—The natural frequency of a pendulum is fixed by its length and the gravitational force; hence to change the natural period of a pendulum it is only necessary to change its length; the mass of the bob itself has no appreciable effect

on the natural frequency. It must be noted, however, that the mass of the bob does have a considerable effect on the *amplitude of vibration* for a given energy in the oscillation, in fact for a given energy the amplitude of vibration varies inversely as the square root of the mass of the bob.

The damping, therefore the decrement, of a swinging pendulum is fixed by the ratio of the frictional forces (set up by the motion) to the mass of the bob; an aluminum bob will have considerable greater decrement than a lead bob, the two being the same diameter. Of two bobs of the same material the smaller will have the higher damping because the mass varies as the cube of the diameter and the air friction in the bob approximately as the square of the diameter; the air friction on the string will be the same for both. Hence a small bob, or one of less dense material, will have greater damping than a large heavy one.

The coupling of the two pendulums depends, for a given length of pendulum, on the distance apart of the points of support, a and b , and on the tightness of the supporting string. The farther apart the points of attachment a and b , and the tighter the string the less the coupling of the two pendulums. For a given tension of the supporting string, and a given separation of the points of attachment, the coupling increases as the lengths of the pendulums are decreased.

The decrement of these pendulums is much less than the decrement of a radio circuit; if it is desired to give the pendulums a greater damping the bobs may be made to swing in a pan of water, or other liquid, or an air damping vane may be fastened to the pendulum string; the closer the vane is placed to the bob the greater will be its damping effect.

By watching the motion of the bobs under various conditions the following approximate deductions may be drawn:

1. For all conditions the motion of either bob is a complex harmonic motion, the amplitude varying periodically from a maximum to a minimum, the average value of the amplitude gradually decreasing.
2. The maximum variation in amplitude occurs in case the two pendulums have the same natural frequency, the minimum amplitude of each pendulum for this case being practically zero.
3. If the two pendulums have the same mass the maximum amplitude of each is nearly the same, if not of the same mass, the lighter bob has the greater maximum amplitude.
4. The period of oscillation for each pendulum (time between successive passages through zero displacement, in the same direction) is practically constant with similar pendulums, the same as the natural period of either pendulum) at all times except when the amplitude is going through its minimum values; at this time a sudden reversal of phase takes place in the motion so that the motion gains (or loses) nearly one half a cycle at this time.

5. During the time a pendulum is gaining amplitude its motion lags nearly 90° behind that of the other pendulum; when its amplitude is decreasing its motion is slightly more than 90° ahead of that of the other pendulum.

6. The amplitude of the first pendulum (the one originally displaced to start oscillations) varies from a maximum to a minimum, the value of this minimum depending upon the relative lengths of the pendulums; for equal lengths the minimum is practically zero, but the minimum increases in value as the ratio of lengths departs from unity value. For all conditions, however, the amplitude of the second pendulum varies from maximum to zero.

7. The time between successive maxima and minima of amplitude depends entirely on the coupling; the tighter the coupling the more rapidly the successive maxima follow one another.

8. Beats (periodic variations in amplitude) always occur unless the coupling is weak and damping is high. In fact practically the only way to prevent beats is to make the damping so high that for the coupling in question the time between beats (as determined for low value of damping) is sufficient to allow nearly complete dissipation of the energy originally put into the first pendulum.

9. If after the first pendulum has given its energy to the second pendulum (first minimum amplitude of the first pendulum) it is in some way disconnected from the second by cutting its string (or merely by holding the first bob so that it cannot move), the second pendulum will oscillate at its own natural frequency, and with its own decrement, until all the energy originally in the first pendulum has been dissipated by the losses in the second. This condition illustrates the operation of a so-called "quenched spark" transmitting set.

Analysis of the Motion of Coupled Pendulums.—The peculiar motion of each of the oscillating pendulums discussed in the previous paragraph can be produced synthetically, more easily than would be supposed. If we let v_1 and v_2 be the actual velocities of the two bobs, both of changing phase and amplitude we may write,

$$v_1 = V_1 \epsilon^{-\alpha_1 t} \sin 2\pi f' t + V_2 \epsilon^{-\alpha_2 t} \sin 2\pi f'' t, \quad \dots \quad (26)$$

$$v_2 = V_1 \epsilon^{-\alpha_1 t} \sin 2\pi f' t + V_2 \epsilon^{-\alpha_2 t} \sin (2\pi f'' t + \pi), \quad \dots \quad (27)$$

where f' and f'' are lower and higher respectively than the natural period of each pendulum and V_1 and V_2 are maximum velocities of these two component velocities, and α_1 and α_2 are the damping factors of the coupled system for the two frequencies f' and f'' . In Fig. 15 are shown the graphs of Eqs. (26) and (27), when applied to pendulums of equal length; the resultant v_1 and v_2 will be recognized at once as the form of the velocity

of the two coupled pendulums, v_1 corresponding to the pendulum originally displaced to start vibrations; the reversal of phase at the times of minimum amplitude is well shown in the curves. In these curves the damping has been neglected; for the ordinary pendulum the damping is very small for so short a time as shown in Fig. 15.

After having clearly in mind the phenomena which occur in the pair of coupled pendulums we will analyze mathematically the currents in two coupled electrical circuits and shall find solutions exactly similar to Eqs. (26) and (27).

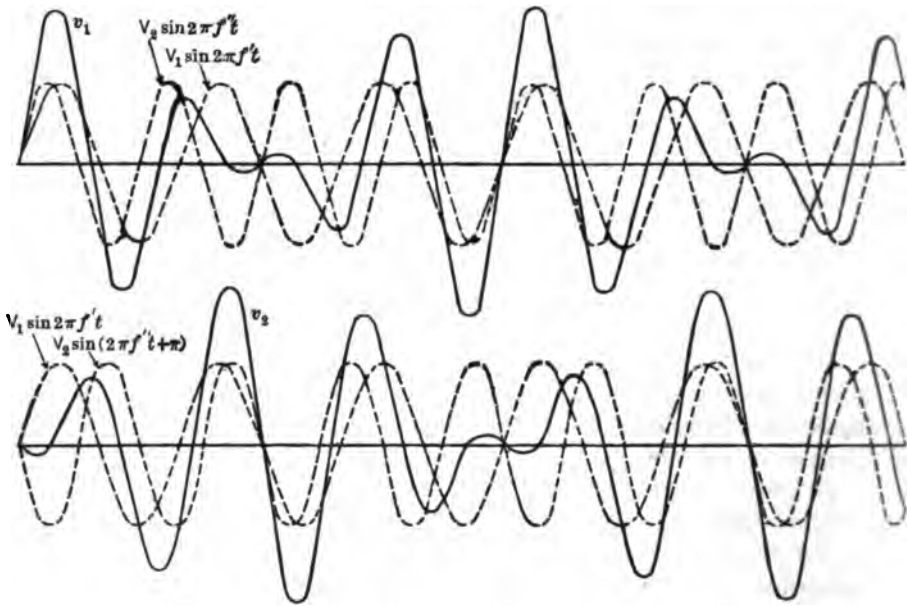

FIG. 15.—Full line curves show actual motion of the two bobs of Fig. 14 for tight coupling; the dashed lines represent the two sinusoidal components of the actual complex motion.

Analysis of Oscillations in Coupled Circuits.—When the switch S , (Fig. 16), is closed currents flow in each circuit and the equation of reactions for each circuit is given by

$$L_1 D^2 q_1 + M D^2 q_2 + R_1 D q_1 + \frac{q_1}{C_1} = 0, \dots \dots \dots (28)$$

$$L_2 D^2 q_2 + M D^2 q_1 + R_2 D q_2 + \frac{q_2}{C_2} = 0, \dots \dots \dots (29)$$

where the letters have the meaning shown in Fig. 16, M being the mutual induction between L_1 and L_2 and q_1 and q_2 being the charges on condensers C_1 and C_2 respectively. D stands for $\frac{d}{dt}$ and D^2 for $\frac{d^2}{dt^2}$, etc.

By differentiating (28) twice

$$C_1 L_1 D^3 q_1 + C_1 M D^3 q_2 + C_1 R_1 D^2 q_1 + D q_1 = 0, \dots (30)$$

$$C_1 L_1 D^4 q_1 + C_1 M D^4 q_2 + C_1 R_1 D^3 q_1 + D^2 q_1 = 0. \dots (31)$$

Similarly for circuit (2)

$$C_2 L_2 D^3 q_2 + C_2 M D^3 q_1 + C_2 R_2 D^2 q_2 + D q_2 = 0, \dots (32)$$

$$C_2 L_2 D^4 q_2 + C_2 M D^4 q_1 + C_2 R_2 D^3 q_2 + D^2 q_2 = 0. \dots (33)$$

Multiply (31) by $C_2 L_2$ and (33) by $C_1 M$ and subtract

$$C_1 C_2 (L_1 L_2 - M^2) D^4 q_1 + C_1 C_2 L_2 R_1 D^3 q_1 + C_2 L_2 D^2 q_1 - C_1 C_2 M R_2 D^3 q_2 - C_1 M D^2 q_2 = 0. \dots (34)$$

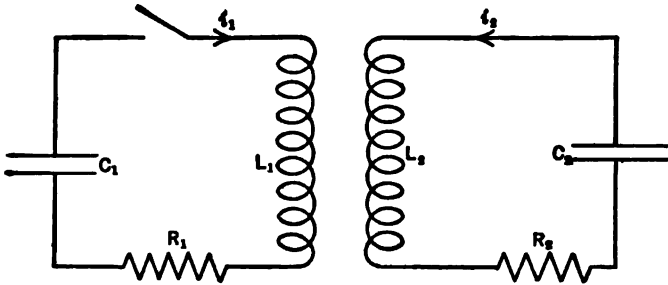

FIG. 16.—When the switch is closed C_1 will discharge through L_1 and R_1 ; current will also be set up in circuit 2, the actual current in the two circuits being similar to the motion of the pendulum bobs of Fig. 14.

Multiply (30) by $C_2 R_2$ and add to (34).

$$C_1 C_2 (L_1 L_2 - M^2) D^4 q_1 + C_1 C_2 (L_2 R_1 + L_1 R_2) D^3 q_1 + (C_2 L_2 + C_1 C_2 R_1 R_2) D^2 q_1 - C_1 M D^2 q_2 + C_2 R_2 D q_1 = 0. \dots (35)$$

Add (28) to (35) and get

$$C_1 C_2 (L_1 L_2 - M^2) D^4 q_1 + C_1 C_2 (L_2 R_1 + L_1 R_2) D^3 q_1 + (C_1 L_1 + C_2 L_2 + C_1 C_2 R_1 R_2) D^2 q_1 + (C_1 R_1 + C_2 R_2) D q_1 + q_1 = 0. \dots (36)$$

By a similar procedure an identical equation can be obtained for q_2 .

The exact solution of Eq. (36) is not generally attempted in texts on Radio; it is lengthy and the exact solution¹ differs but little from the approximate solution given below.

Determination of the Two Frequencies of Oscillation.—In using Eq. (36) to obtain the frequencies of oscillation the solution is much simplified by making an assumption which is justified in all ordinary radio circuits,

¹ For the exact solution the student is referred to an excellent article by F. E. Pernot in Vol. 1, No. 8, University of California Publications in Engineering.

i.e., the resistance of the circuit has a negligible effect on the frequency of oscillation. We may therefore neglect the resistance terms in Eq. (36) in solving for the periods of oscillation; by doing this we get the comparatively simple equation,

$$\left(1 - \frac{M^2}{L_1 L_2}\right) D^4 q_1 + \left(\frac{1}{L_1 C_1} + \frac{1}{L_2 C_2}\right) D^2 q_1 + \frac{q_1}{C_1 L_1 C_2 L_2} = 0. \quad (37)$$

By substituting

$$k^2 = \frac{M^2}{L_1 L_2}, \quad \omega_1^2 = \frac{1}{L_1 C_1}, \quad \omega_2^2 = \frac{1}{L_2 C_2}$$

this becomes,

$$(1 - k^2) D^4 q_1 + (\omega_1^2 + \omega_2^2) D^2 q_1 + \omega_1^2 \omega_2^2 q_1 = 0. \quad (38)$$

A similar analysis for q_2 would yield

$$(1 - k^2) D^4 q_2 + (\omega_1^2 + \omega_2^2) D^2 q_2 + \omega_1^2 \omega_2^2 q_2 = 0. \quad (39)$$

The solutions of (38) and (39) are, by inspection, of trigonometric form, so we put

$$q_1 = A_1 \cos(\omega t + \phi), \quad (40)$$

$$q_2 = A_2 \cos(\omega t + \phi'). \quad (41)$$

By differentiating these equations and inserting the values of the proper derivatives in Eqs. (38) and (39) we obtain the two values of ω .

$$\omega'' = \sqrt{\frac{\omega_1^2 + \omega_2^2 + \sqrt{(\omega_1^2 + \omega_2^2)^2 - 4\omega_1^2 \omega_2^2 (1 - k^2)}}{2(1 - k^2)}}, \quad (42)$$

and

$$\omega' = \sqrt{\frac{\omega_1^2 + \omega_2^2 - \sqrt{(\omega_1^2 + \omega_2^2)^2 - 4\omega_1^2 \omega_2^2 (1 - k^2)}}{2(1 - k^2)}}. \quad (43)$$

If we now suppose the two circuits of Fig. 16 to be tuned alike, i.e., $L_1 C_1 = L_2 C_2$, we can simplify Eqs. (42) and (43) very much. By introducing the condition that $\omega_1 = \omega_2 = \omega$ we get,

$$\omega'' = \frac{\omega}{\sqrt{1 - k}}. \quad (44)$$

and

$$\omega' = \frac{\omega}{\sqrt{1 + k}}. \quad (45)$$

And it is to be noticed at this point of the analysis that these two frequencies are exactly the same as those given in Eqs. (103) and (104) of Chapter I for coupled circuits excited by an alternating e.m.f. of variable frequency. Indeed from the similarity of procedure we may conclude

that a complex circuit having sufficiently low resistance, if left free to oscillate after being excited in some way or other, will oscillate at those frequencies for which the system has zero reactance when excited by an alternating e.m.f.

If, therefore, the natural periods of an electric circuit are desired it is only necessary to excite the circuit by an alternating e.m.f. of variable frequency and note those frequencies for which the power factor of the system is unity. When left free to vibrate, the circuit will, in general, oscillate at all these frequencies simultaneously, the energy dividing between the various frequencies.

This general theorem in resonance is a very useful one. Suppose three circuits as pictured in Fig. 17 all coupled together in any complex way possible; knowing all the constants of the circuits it would be possible to set up the differential equations and, after some laborious transformations, it would be possible to so combine them as to eliminate all but one variable. The resulting equation would, however, be difficult to solve, because schemes have not yet been evolved for solving an equation of the sixth degree.

But if an alternating e.m.f. is introduced into the complex network, and the frequency of this e.m.f. be varied through as wide a range as necessary, there will be found three frequencies for which the network shows resistance only, the reactance being zero. These are the three free periods at which network will oscillate if excited and left to itself.

The point where the power is introduced when determining the three resonant frequencies by impressing an e.m.f. is of no importance; it will be found that the same frequencies will result in unity power factor if the alternator is introduced in any line of the whole network, care being taken that the alternator impedance does not appreciably alter the constants of the circuit.

It must be borne in mind that the previous remarks hold good only for circuits having low damping factors; the argument depends upon the assumption that this resistance does not appreciably affect the frequency of oscillation. The assumption is always warranted because the radio engineer is seldom interested in inefficient circuits, i.e., circuits having a low ratio of reactance to resistance.

We therefore write the solution of (38) and (39),

$$q_1 = A_1 \cos(\omega''t + \phi'') + B_1 \cos(\omega't + \phi'). \quad \dots \quad (46)$$

$$q_2 = A_2 \cos(\omega''t + \phi'') + B_2 \cos(\omega't + \phi'). \quad \dots \quad (47)$$

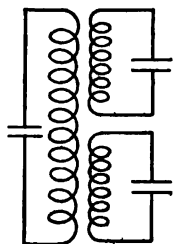

FIG. 17. — General case of three coupled circuits.

By differentiation of (46) and (47), we get the two currents,

$$\begin{aligned} i_1 &= A_1 \omega'' \sin(\omega''t + \phi'') + B_1 \omega' \sin(\omega't + \phi') \\ &= I''_1 \sin(\omega''t + \phi'') + I'_1 \sin(\omega't + \phi'), \dots \dots \dots (48) \end{aligned}$$

and

$$\begin{aligned} i_2 &= A_2 \omega'' \sin(\omega''t + \phi'') + B_2 \omega' \sin(\omega't + \phi') \\ &= I''_2 \sin(\omega''t + \phi'') + I'_2 \sin(\omega't + \phi'), \dots \dots \dots (49) \end{aligned}$$

The constants of Eqs. (48) and (49) must be chosen correctly to satisfy the initial conditions of the problem.

It will be noticed that these solutions give alternating currents of constant amplitude, evidently an impossible condition for the circuit of Fig. 16. The currents must rapidly die away as the energy originally stored in the condenser C_1 is used up in the resistances of the two circuits. The reason no damping term appears in the expressions for i_1 and i_2 is the neglect of the resistance terms of Eq. (36) in passing to Eq. (37). Of course, a circuit having no resistance has no damping.

Before proceeding to further analysis of the currents in the two circuits it is well to summarize the results so far obtained. *When the switch in circuit 1 is closed complex shaped alternating currents begin to flow in both circuits 1 and 2; these complex currents are exactly represented by two currents of frequencies fixed by ω'' and ω' , in each circuit.* We have therefore to determine the relative amplitude and phases of four currents I'_1 and I'_2 of frequency fixed by ω' (I'_1 in circuit 1 and I'_2 in circuit 2), and I''_1 and I''_2 of frequency fixed by ω'' (I''_1 in circuit 1 and I''_2 in circuit 2).

Relative Amplitude and Phases of Currents in the Two Circuits.—An analysis of the phase and magnitude relations of the four currents I'_1 , I''_1 , I'_2 , I''_2 was carried out by Chaffee and the deductions verified by an ingenious experiment; the results given below are taken from his paper.¹

By using Eqs. (46) and (47) in combination with Eq. (28) (neglecting the resistance term in the latter) we get,

$$\begin{aligned} A_1 \left(\frac{1}{L_1 C_1} - \omega''^2 \right) &= \frac{A_2 M \omega''^2}{L_1}, \\ B_1 \left(\frac{1}{L_1 C_1} - \omega'^2 \right) &= \frac{B_2 M \omega'^2}{L_1}, \end{aligned}$$

¹"Amplitude Relations in Coupled Circuits," E. Leon Chaffee, Proc. I. R. E., Vol. 4, No. 3, June, 1916.

from which

$$\frac{A_2}{A_1} = -\frac{\omega''^2 - \omega_1^2}{k\omega''^2} \sqrt{\frac{L_1}{L_2}}$$

$$\frac{B_2}{B_1} = \frac{\omega_1^2 - \omega'^2}{k\omega'^2} \sqrt{\frac{L_1}{L_2}}$$

$$\frac{I''_2}{I''_1} = -\frac{\omega''^2 - \omega_1^2}{k\omega''^2} \sqrt{\frac{L_1}{L_2}} \dots \dots \dots (50)$$

$$\frac{I'_2}{I'_1} = \frac{\omega_1^2 - \omega'^2}{k\omega'^2} \sqrt{\frac{L_1}{L_2}} \dots \dots \dots (51)$$

Eq. (50) gives the ratio of amplitudes of the short waves in the two circuits and (51) that of the long waves. As ω'' is greater than ω_1 (see Eq. (42)), it is evident that I''_2 and I''_1 are in opposite phase; when one is positive the other is negative. The long waves I'_2 and I'_1 are in the same phase, however, as their ratio is positive, ω_1 being greater than ω' for all conditions of coupling.

In the oscillation transformer of a transmitting set, therefore, the effective flux for the short waves is much less than it is for the long waves; of course, this might be surmised, because the short wave in each circuit could only occur if the effective L_1 and L_2 were each diminished by the action of the other, which means currents in the two coils nearly 180° out of phase. The long waves, by a similar argument, must occur because the mutual action of L_1 and L_2 increases the effective inductance of each; this could only occur if the long wave currents in the two coils L_1 and L_2 are in phase, i.e., they magnetize their mutual field in the same direction.

To express the amplitude relation of the two currents in each circuit it is more convenient to express the relations of Eqs. (42) and (43) in terms of wave lengths. Using the relation $\lambda = \frac{2\pi V}{\omega}$ for each frequency involved (V being velocity of propagation of the electromagnetic waves), we get,

$$\lambda'' = \sqrt{\frac{\lambda_1^2 + \lambda_2^2 - \sqrt{(\lambda_1^2 - \lambda_2^2)^2 + 4k^2\lambda_1^2\lambda_2^2}}{2}} \dots \dots (52)$$

$$\lambda' = \sqrt{\frac{\lambda_1^2 + \lambda_2^2 + \sqrt{(\lambda_1^2 - \lambda_2^2)^2 + 4k^2\lambda_1^2\lambda_2^2}}{2}} \dots \dots (53)$$

As Eqs. (42) and (43) were simplified by supposing the two circuits tuned alike, i.e., $\lambda_1 = \lambda_2 = \lambda$ we may write, for this condition, Eqs. (52) and (53) in the abbreviated forms

$$\lambda'' = \lambda\sqrt{1-k} \dots \dots \dots (54)$$

$$\lambda' = \lambda\sqrt{1+k} \dots \dots \dots (55)$$

Eqs. (50) and (51) may also be written in terms of wave length and they become,

$$\frac{I''_2}{I''_1} = -\frac{1 - \left(\frac{\lambda''}{\lambda_1}\right)^2}{k} \sqrt{\frac{L_1}{L_2}} \dots \dots \dots (56)$$

$$\frac{I'_2}{I'_1} = \frac{\left(\frac{\lambda'}{\lambda_1}\right)^2 - 1}{k} \sqrt{\frac{L_1}{L_2}} \dots \dots \dots (57)$$

To determine the ratio $\frac{I'_1}{I''_1}$ and $\frac{I'_2}{I''_2}$ we set down the initial conditions of the circuit. When $t=0$ (time of closing switch) $q_1=Q_0$, $q_2=0$, $i_1=0$, and $i_2=0$. Using these values in Eqs. (46), (47), (48) and (49), we get,

$$Q_0 = A_1 \cos \phi'' + B_1 \cos \phi'. \dots \dots \dots (58)$$

$$0 = A_2 \cos \phi'' + B_2 \cos \phi'. \dots \dots \dots (59)$$

$$0 = A_1 \omega'' \sin \phi'' + B_1 \omega' \sin \phi' = I''_1 \sin \phi'' + I'_1 \sin \phi'. \dots (60)$$

$$0 = A_2 \omega'' \sin \phi'' + B_2 \omega' \sin \phi' = I''_2 \sin \phi'' + I'_2 \sin \phi'. \dots (61)$$

To satisfy these conditions we must have $\phi' = \phi'' = 0$. Then we find as $A_2 = -B_2$, and $I''_2 = A_2 \omega''$ and $I'_2 = B_2 \omega'$, that

$$\frac{I'_2}{I''_2} = -\frac{\omega'}{\omega''} = -\frac{\left(\frac{\lambda''}{\lambda_1}\right)}{\left(\frac{\lambda'}{\lambda_1}\right)} \dots \dots \dots (62)$$

Dividing (50) by (51)

$$\frac{I''_2 I'_1}{I''_1 I'_2} = -\frac{\omega''^2 - \omega_1^2}{\omega''^2} \frac{\omega'^2}{\omega_1^2 - \omega'^2} = -\frac{\omega''^2 - \omega_1^2}{\omega_1^2 - \omega'^2} \frac{\omega'^2}{\omega''^2}$$

Multiplying by (62) and get,

$$\frac{I'_1}{I''_1} = \frac{\omega''^2 - \omega_1^2}{\omega_1^2 - \omega'^2} \frac{\omega'^3}{\omega''^3} = \frac{1 - \left(\frac{\lambda''}{\lambda_1}\right)^2}{\left(\frac{\lambda'}{\lambda_1}\right)^2 - 1} \left(\frac{\lambda''}{\lambda_1}\right) \dots \dots \dots (63)$$

For convenience in using the relations of Eqs. (62) and (63), the values of $\frac{\lambda''}{\lambda_1}$ and $\frac{\lambda'}{\lambda_1}$ have been calculated by Chaffee and are reproduced in Fig. 18. In this figure are shown the variations in $\frac{\lambda''}{\lambda_1}$ and $\frac{\lambda'}{\lambda_1}$ as $\frac{\lambda_2}{\lambda_1}$ is varied, this ratio being varied by varying λ_2 by a variation in condenser C_2 . This keeps k constant as the ratio $\frac{\lambda_2}{\lambda_1}$ is varied.

To get the magnitudes of the four currents, we solve for $A_1, B_1,$ and $A_2, B_2.$ From (58)

$$Q_0 = A_1 + B_1$$

From (60)

$$I'_1 = B_1 \omega' \text{ and } I''_1 = A_1 \omega'',$$

from which

$$\frac{B_1 \omega'}{A_1 \omega''} = \frac{I'_1}{I''_1}$$

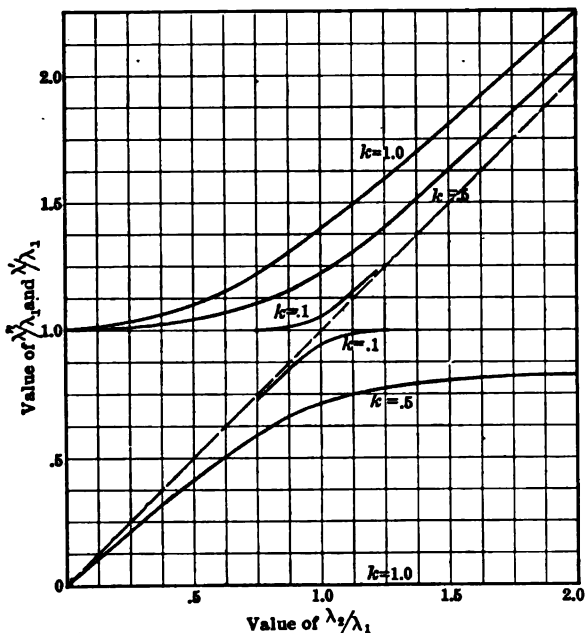

FIG. 18.—Variation in ratios of $\lambda''/\lambda,$ and $\gamma''/\gamma,$ as the ratio of λ_1/λ_2 is varied, for different values of coupling.

From this equation, by using (63),

$$\frac{B_1 \omega'}{A_1 \omega''} = \frac{\omega''^2 - \omega_1^2}{\omega_1^2 - \omega'^2} \frac{\omega'^3}{\omega''^3}$$

or

$$B_1 = A_1 \frac{\omega''^2 - \omega_1^2}{\omega_1^2 - \omega'^2} \frac{\omega'^2}{\omega''^2}$$

Substituting this value of B_1 in above equations for Q_0 gives

$$A_1 = Q_0 \frac{\omega_1^2 - \omega'^2}{\omega''^2 - \omega'^2} \frac{\omega''^2}{\omega_1^2} \dots \dots \dots (64)$$

And as $B_1 = Q_0 - A_1,$ we have

$$B_1 = Q_0 \frac{\omega''^2 - \omega_1^2}{\omega''^2 - \omega'^2} \frac{\omega'^2}{\omega_1^2} \dots \dots \dots (65)$$

From (61)

$$A_2 = \frac{I''_2}{\omega''}$$

and by using (50) then substituting for I_1'' its equal $\omega'' A_1$, we get

$$A_2 = -A_1 \left(\frac{\omega''^2 - \omega_1^2}{k\omega''^2} \right) \sqrt{\frac{L_1}{L_2}}$$

then using (64)

$$A_2 = -Q_0 \frac{(\omega_1^2 - \omega'^2)(\omega''^2 - \omega_1^2)}{k\omega_1^2(\omega''^2 - \omega'^2)} \sqrt{\frac{L_1}{L_2}}; \quad \dots \quad (66)$$

then from (59),

$$B_2 = Q_0 - A_2 = Q_0 \frac{(\omega_1^2 - \omega'^2)(\omega''^2 - \omega_1^2)}{k\omega_1^2(\omega''^2 - \omega'^2)} \sqrt{\frac{L_1}{L_2}} \quad \dots \quad (67)$$

Substituting the values of Eqs. (64-67) in (48) and (49), we get,

$$i_1 = \omega_1 Q_0 (F''_1 \sin \omega'' t + F'_1 \sin \omega' t) \quad \dots \quad (68)$$

and

$$i_2 = \omega_1 Q_0 \sqrt{\frac{L_1}{L_2}} (F''_2 \sin \omega'' t + F'_2 \sin \omega' t), \quad \dots \quad (69)$$

in which the F coefficients are factors depending on the condition of tuning, must conveniently expressed in terms of λ'' , λ' and λ_1 . They are

$$F''_1 = \frac{\left(\frac{\lambda'}{\lambda_1}\right)^2 - 1}{\left(\frac{\lambda'}{\lambda_1}\right)^2 - \left(\frac{\lambda''}{\lambda_1}\right)^2} \frac{1}{\left(\frac{\lambda''}{\lambda_1}\right)}$$

$$F'_1 = \frac{1 - \left(\frac{\lambda''}{\lambda_1}\right)^2}{\left(\frac{\lambda'}{\lambda_1}\right)^2 - \left(\frac{\lambda''}{\lambda_1}\right)^2} \frac{1}{\left(\frac{\lambda''}{\lambda_1}\right)}$$

$$F''_2 = -\frac{\left[1 - \left(\frac{\lambda''}{\lambda_1}\right)^2\right] \left[\left(\frac{\lambda'}{\lambda_1}\right)^2 - 1\right]}{k \left[\left(\frac{\lambda'}{\lambda_1}\right)^2 - \left(\frac{\lambda''}{\lambda_1}\right)^2\right] \left(\frac{\lambda''}{\lambda_1}\right)}$$

$$F'_2 = \frac{\left[1 - \left(\frac{\lambda''}{\lambda_1}\right)^2\right] \left[\left(\frac{\lambda'}{\lambda_1}\right)^2 - 1\right]}{k \left[\left(\frac{\lambda'}{\lambda_1}\right)^2 - \left(\frac{\lambda''}{\lambda_1}\right)^2\right] \left(\frac{\lambda''}{\lambda_1}\right)}$$

The values of these F factors are plotted in Figs. 19-22, which serve to show how the four different currents vary as C_2 , the condenser in circuit 2, is varied, other things remaining constant. An examination of these curves shows that with weak coupling and tuned circuits the variation in amplitude (due to beats) is from maximum to zero as the values of F''_1 and F'_1 are equal in magnitude as are those of F''_2 and F'_2 . For tighter couplings the ratio of $\frac{\lambda_2}{\lambda_1}$ must be different than unity to make $F''_1 = F'_1$

or $F''_2 = F'_2$. Furthermore with other coupling than very loose no ratio of $\frac{\lambda_2}{\lambda_1}$ can be found which will make both $F''_1 = F'_1$ and $F''_2 = F'_2$ so that,

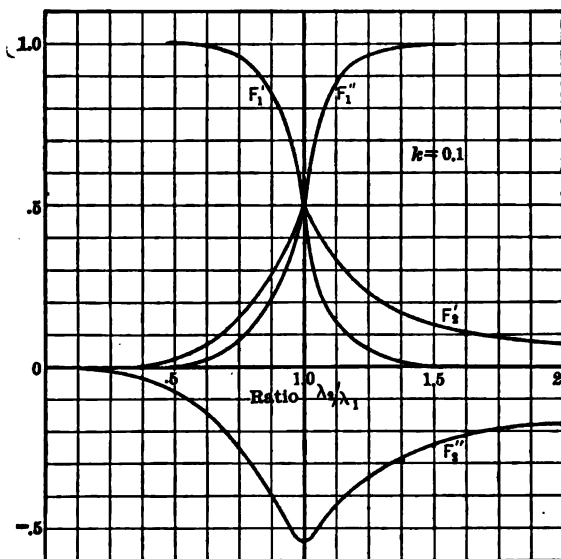

FIG. 19.—Values of the F coefficients for 10% coupling.

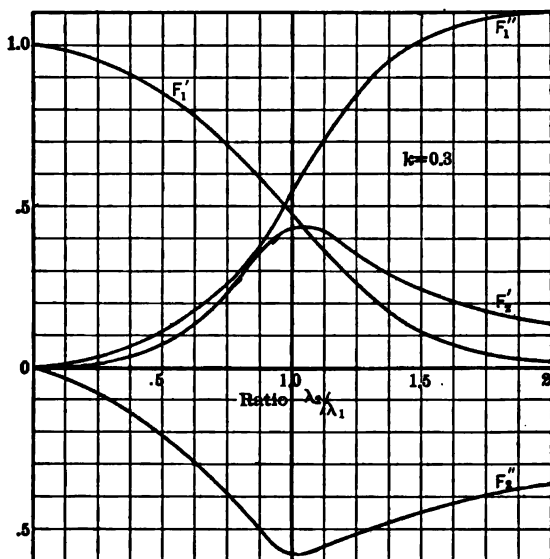

FIG. 20.—Values of the F coefficients for 30% coupling.

except for very weak coupling the beats are not complete in both circuits, i.e., the minimum amplitude is not zero. It may be made zero in circuit 1

for any value of coupling by the proper amount of de-tuning, but the values of F''_2 and F'_2 are such as to preclude the possibility of zero amplitude beats

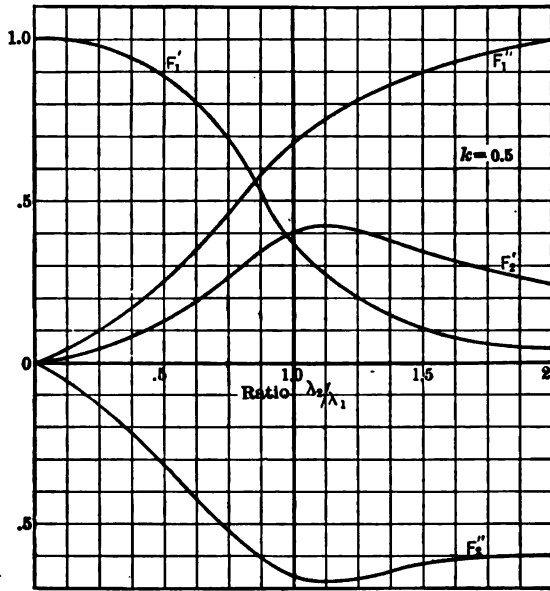

FIG. 21.—Values of the F coefficients for 50% coupling.

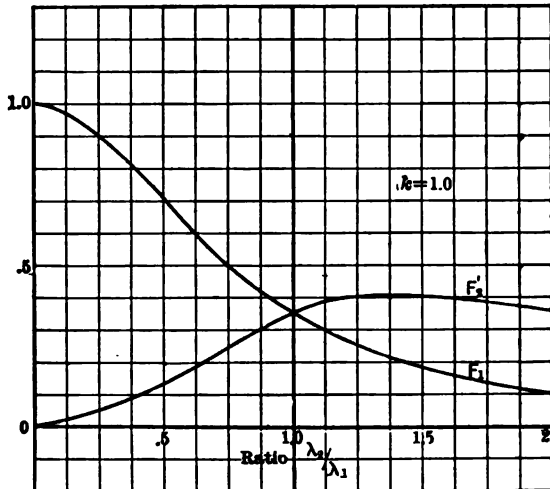

FIG. 22.—Values of the F coefficients for 100% coupling.

for any except the weakest coupling, no matter how much λ_2 and λ_1 are made to differ.

A critical examination of the foregoing analysis shows that maximum

current occurs in the second circuit when the ratio of $\frac{\lambda_2}{\lambda_1}$ is slightly greater than unity. This might have an important bearing on the use of a wave meter; this instrument is a coil and variable condenser which has an ammeter (or other device) for indicating resonance with the circuit, being tested. A precise analysis shows that maximum current will occur in this wave meter when its natural period is somewhat longer than that of the circuit being tested; as maximum current in the wave meter is ordinarily taken to signify resonance with the circuit tested it is evident that an appreciable error might be incurred.

It appears, however, that with a coupling between wave meter and the circuit tested as high as 10 per cent the error in wave meter reading is less than 1 per cent and as the wave meter coupling is, in practice, seldom more than 1 per cent or 2 per cent, the error is probably well within the precision of measurement.

The previous analysis of amplitudes, resulting in Eqs. (68) and (69) for the currents in the two circuits, was carried out without considering the resistance terms in the original equations, (28) and (29). The consideration of damping would have greatly complicated the derivations, and the damping factors can be introduced now without invalidating the previous work.

The damping factor of the high-frequency wave is the same for the high-frequency current in both circuits and similarly for the low-frequency wave. If we call the damping factors α'' and α' , it is possible to derive the relations¹

$$\alpha'' = \frac{1}{2(1-k)} \left(\frac{R_1}{2L_1} + \frac{R_2}{2L_2} \right), \dots \dots \dots (70)$$

$$\alpha' = \frac{1}{2(1+k)} \left(\frac{R_1}{2L_1} + \frac{R_2}{2L_2} \right), \dots \dots \dots (71)$$

α'' being for the high-frequency currents and α' for the low-frequency currents.

It is to be noticed that if Eqs. (70) and (71) are changed to give decrements (the two circuits being tuned), they assume the forms

$$\delta'' = \frac{1}{\sqrt{1-k}} \left(\frac{\delta_1 + \delta_2}{2} \right)$$

and

$$\delta' = \frac{1}{\sqrt{1+k}} \left(\frac{\delta_1 + \delta_2}{2} \right),$$

¹ A. Oberbeck, Wied. Ann. der Physik, 1895, Vol. 55, p. 623.

where δ_1 and δ_2 are the decrements of the primary and secondary circuits, respectively. These solutions are approximate and good only when the decrements are low.

The complete solutions then become,

$$i_1 = \omega_1 Q_0 (F''_1 \epsilon^{-\alpha''t} \sin \omega''t + F'_1 \epsilon^{-\alpha't} \sin \omega't). \quad (72)$$

$$i_2 = \omega_1 Q_0 \sqrt{\frac{L_1}{L_2}} (F''_2 \epsilon^{-\alpha''t} \sin \omega''t + F'_2 \epsilon^{-\alpha't} \sin \omega't). \quad (73)$$

Actual Shapes of Currents in Coupled Circuits.—In Figs. 23–26 are shown oscillograms of currents in each of two coupled circuits, the cir-

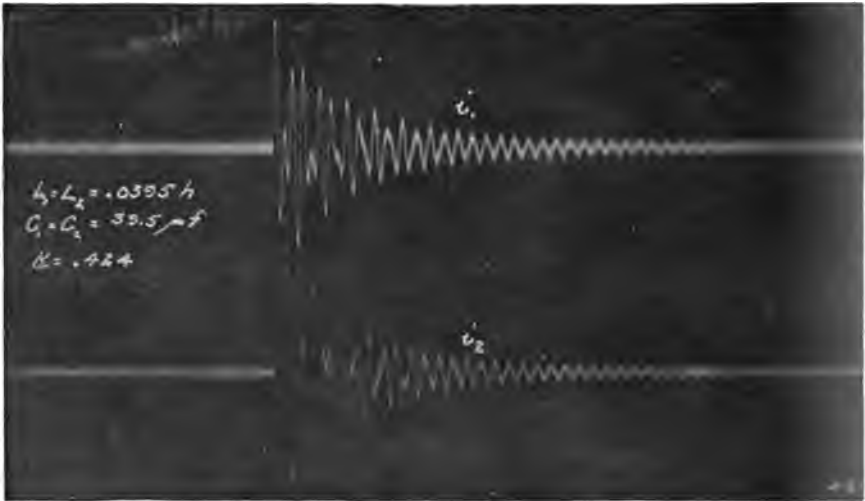

FIG. 23.—Currents in coupled tuned circuits with 42.4% coupling.

cuits being practically identical. For each $L = .0395$ henry and $C = 39.5$ microfarads. The coefficients of coupling were .424, .282, .114, and .0707, respectively, for the several curves. The films do not quite bear out the preceding theory on amplitudes, as the values of F'_1 and F''_1 are evidently not near enough in amplitude to neutralize each other for even the minimum coupling, 7.07 per cent. It is quite likely that the rather high decrement of the circuit had an appreciable effect on the various amplitude factors, not accounted for in the previous analysis.

Frequency of the Actual Complex Current.—By inspection of the films shown in Figs. 23–26 it is seen that the time between successive zero points in the current wave is practically constant (indicating constant frequency); in fact, careful measurement shows the frequency constant (for Fig. 26), within about 1 per cent, *except at the points of minimum amplitude*, where

the time between successive zero points changes very much. Just what changes take place in the magnitude and phase of the current at this time depends altogether upon the relative amplitudes of the two component currents.

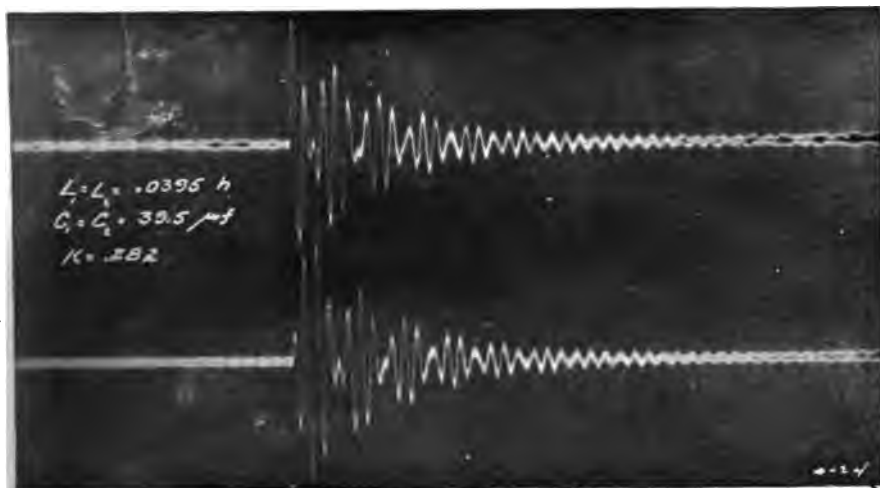

FIG. 24.—Currents in coupled tuned circuits with 28.2% coupling

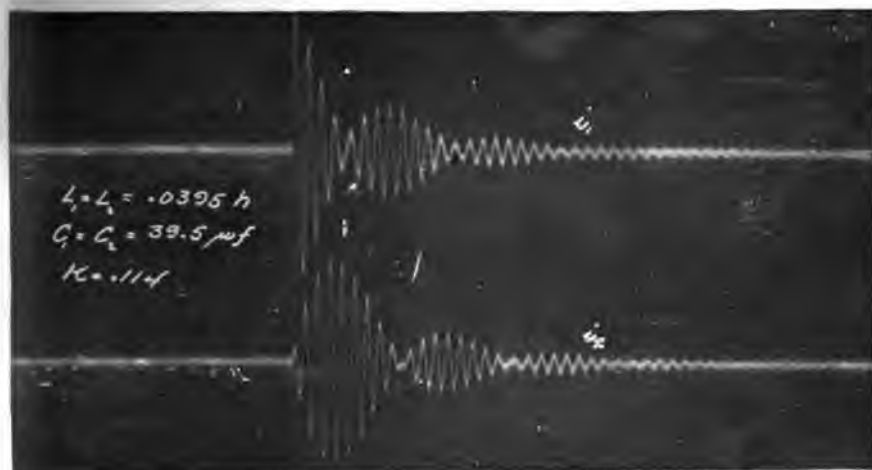

FIG. 25.—Currents in coupled tuned circuits with 11.4% coupling

In Figs. 27, 28, and 29 are shown three possible conditions at this time of minimum amplitude of the actual current. In Fig. 27 we have shown the condition for $F_1'' = .5 F_1'$, in Fig. 28 for $F_1'' = .9 F_1'$ and in

Fig. 29 for $F''_1 = 1.25 F'_1$. For all three figures we have $\omega'' = 1.20\omega'$, which means a value of coupling of the two circuits of about 20 per cent.

It might seem that as the frequency (time between successive zero points) of this "beating" current is constant, that a third circuit, coupled to the circuit carrying this complex current, would respond most strongly if tuned to this frequency. As a matter of fact but little response will be had in this third circuit if tuned to this actual frequency; if tuned to either of the component currents of this actual complex current, however, a strong response will be obtained.

Thus suppose the two circuits of Fig. 16 are each adjusted for a natural period of 100 cycles, and they are coupled 20 per cent. Then the two

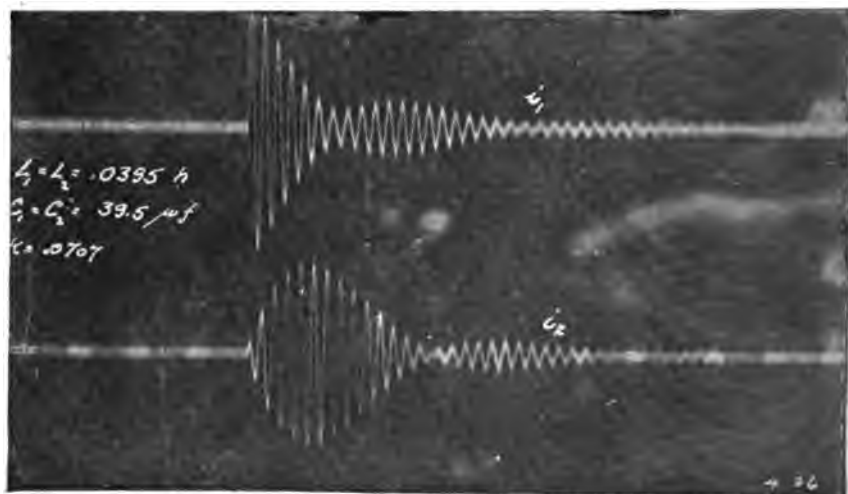

FIG. 26.—Currents in coupled tuned circuits with 7.07% coupling.

frequencies generated, when the condenser in circuit 1 discharges, will be (by Eqs. (44) and (45))

$$f'' = \frac{100}{\sqrt{1-0.2}} = 111.7 \text{ cycles;}$$

$$f' = \frac{100}{\sqrt{1+0.2}} = 91.2 \text{ cycles.}$$

The oscillatory current in each of the circuits will have a period of .01 second (except at the minimum amplitude points) but if a third circuit loosely coupled to either of the others is tuned to a natural period of .01 second the current induced in it will be much smaller than if it (the third circuit) is tuned to a natural frequency of either 111.7 or 91.2.

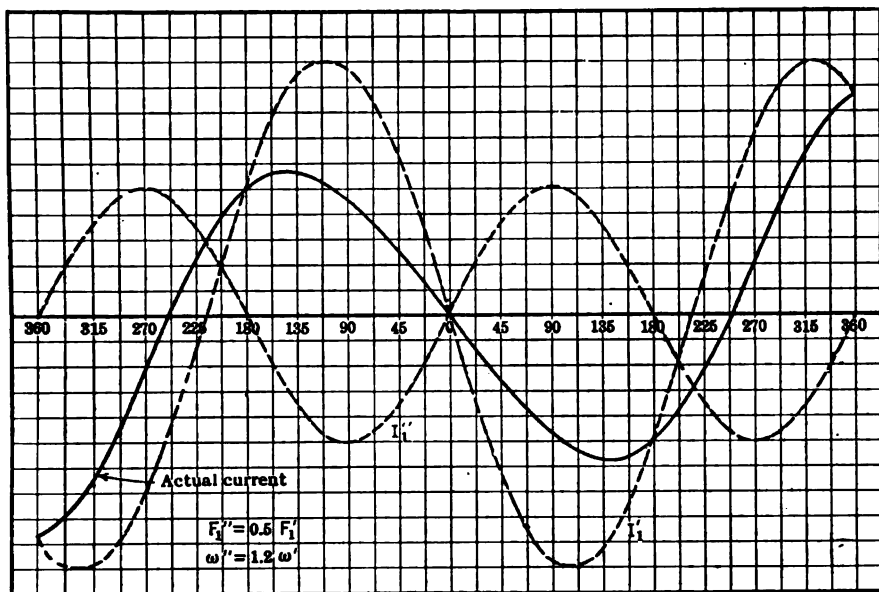

FIG. 27.—Form of current and minimum amplitude, high-frequency current much smaller than low-frequency.

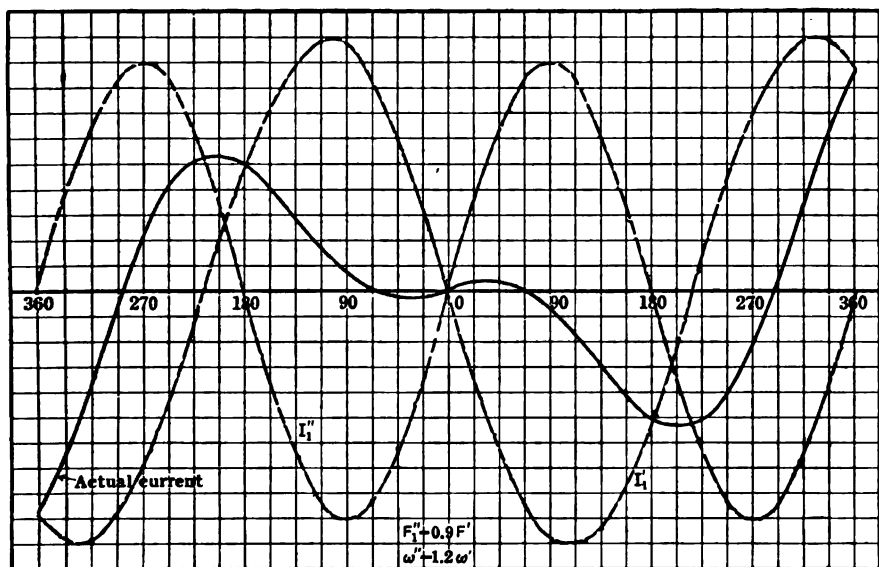

FIG. 28.—Form of current at minimum amplitude, high-frequency current of nearly the same amplitude as low-frequency.

The magnitude of current in this third circuit, as its natural frequency is changed by changing the value of its condenser, will be about as indicated in Fig. 30. The reason for this weak response to the 100-cycle tuning is the reversal of the phase in the exciting current at the minimum amplitude points; what current is built up in circuit 3 during time $t-t_1$, Fig. 31, is destroyed, or neutralized by the action during time t_1-t_2 , because of the phase reversal in the inducing current at time t_1 .

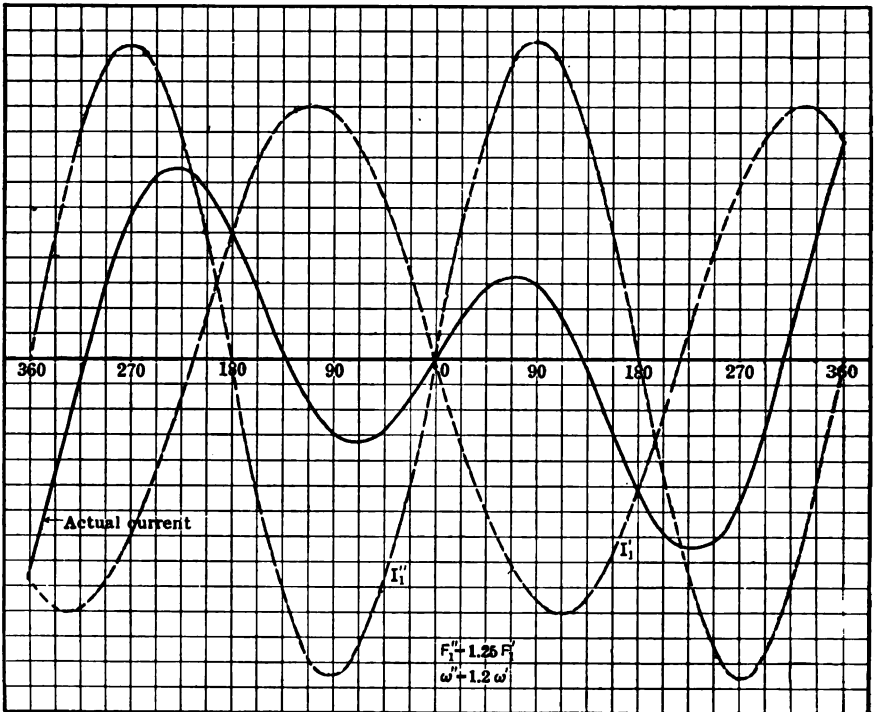

FIG. 29.—Form of current at minimum amplitude, high-frequency current greater than low-frequency.

Vector Representation of Current in Coupled Circuits.—Such a function as that given in Eq. (72) can be represented vectorially but, of course, the vector diagram is not of the ordinary type. If we let the instantaneous value of the current be represented by the projection on the y axis of the resultant vector obtained by adding $F''_1 \epsilon^{-\alpha'' t}$ and $F'_1 \epsilon^{-\alpha' t}$ the construction will be as shown in Fig. 32. When $t=0$ the two vectors coincide in position; with increase in time the F''_1 vector advances its phase over that of F'_1 , so after F'_1 has advanced 90° , as shown at OA the vector F''_1 , has moved to position OB . The resultant of these two vectors OR , gives, by its projection in the OY axis, OD , the instantaneous value of

the actual current i_1 . As the two vectors OA and OB rotate their magnitudes must continually diminish to keep them equal to $F''_1 e^{-\alpha''t}$ and $F'_1 e^{-\alpha't}$. The loci of the terminals of the vectors are logarithmic spirals about the point O . The logarithm of the ratio of the values of a vector, in two successive passages through the same phase gives the decrement

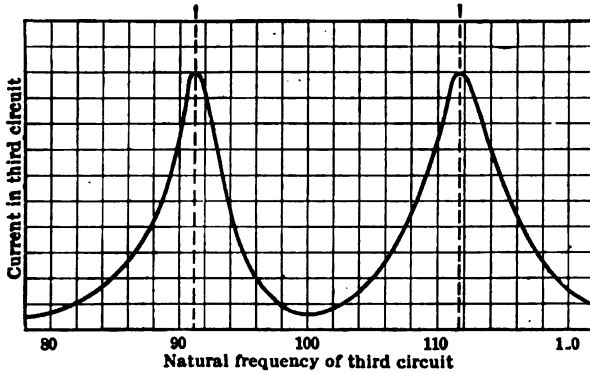

FIG. 30.—Amplitude of current in a third circuit coupled very loosely to either of the two coupled oscillating circuits.

of the current represented by that vector; thus we have $\log_e \frac{OM}{ON} = \delta''$ the logarithmic decrement of the current I''_1 .

The unusual motion of this resultant vector as the two component vectors pass through phase opposition is indicated in Fig. 33. Vector OA , the

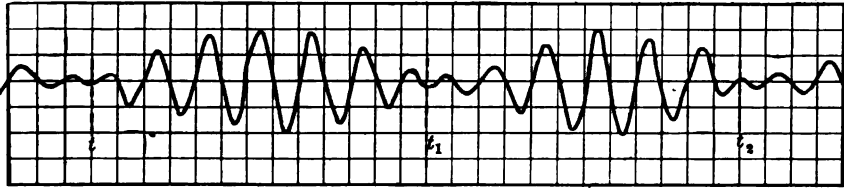

FIG. 31.—At minimum amplitude points the actual current in either of the two oscillating circuits reverses its phase.

one with less angular velocity, is shown stationary and the vector OB is shown in several successive positions around its phase opposition position; OB is slightly greater in magnitude than OA . With OB in the position indicated by OB_1 , the resultant of OA and OB_1 is shown by OR_1 , etc. It may be seen that this resultant vector moves through the angle R_1OR_5 , which is more than 180° , while the vector OB has moved about 45° .

The case of OB being smaller than OA is given in Fig. 34; in this case when OB goes through its opposition phase the resultant vector,

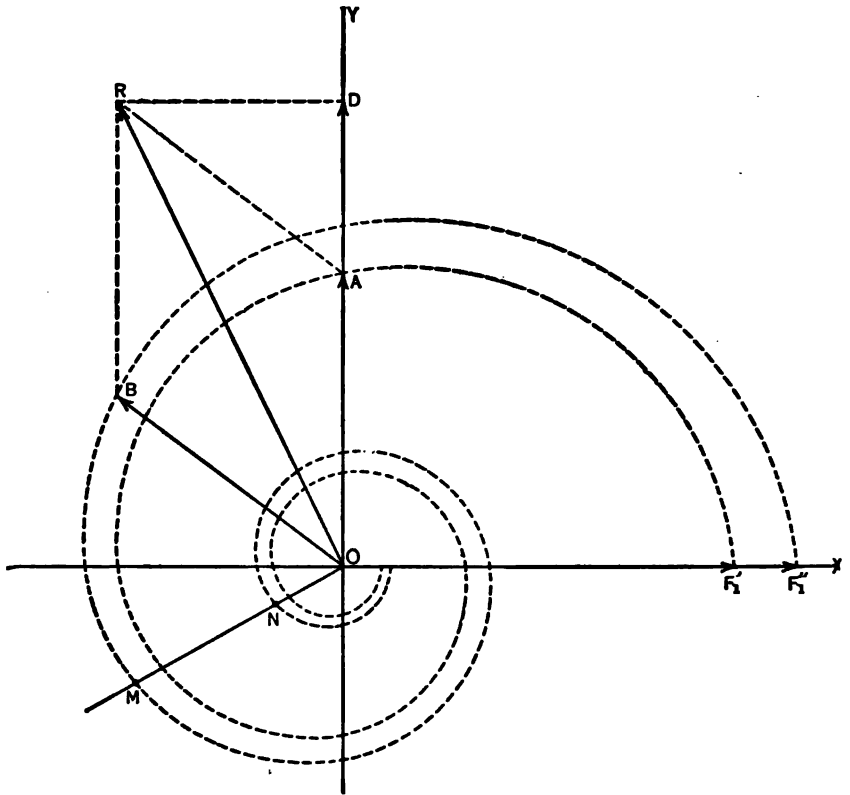

FIG. 32.—For damped sine waves the terminals of the e.m.f. vectors must lie on logarithmic spirals.

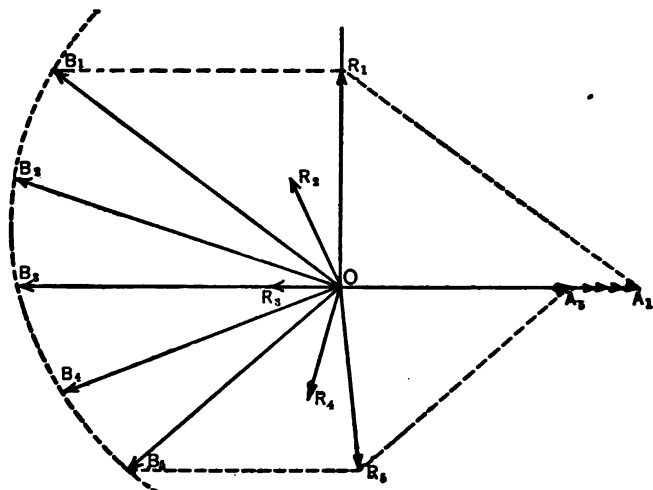

FIG. 33.—Resultant vector when high-frequency current has the greater amplitude.

instead of speeding up as it did in Fig. 33, slows down and goes through the successive values OR_1, OR_2, OR_3 , etc., for the correspondingly marked

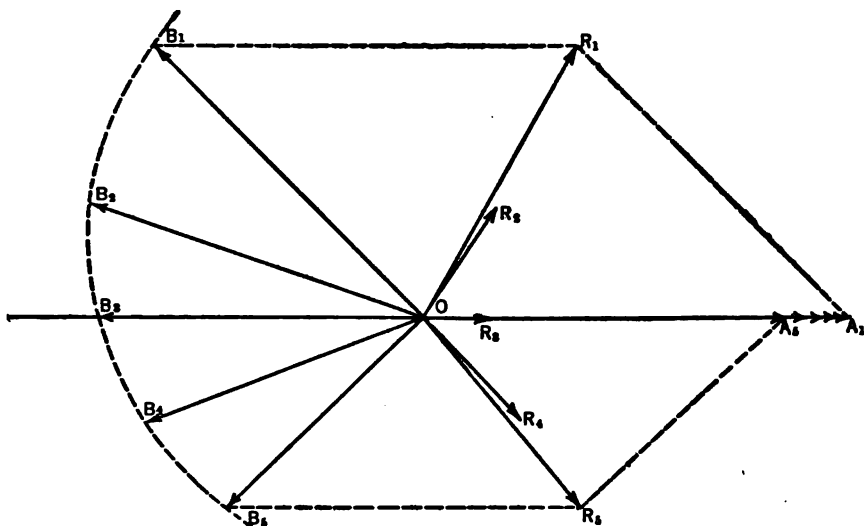

FIG. 34.—Resultant vector when low-frequency current has the greater amplitude.

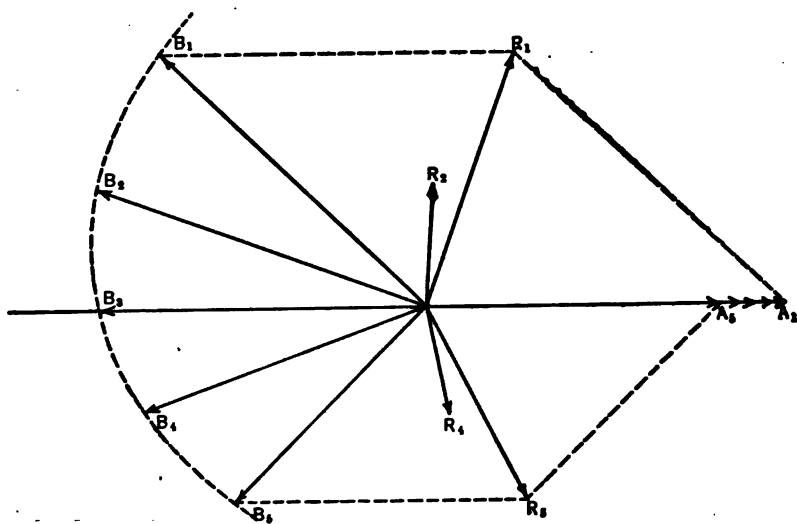

FIG. 35.—Resultant vector when both currents have the same amplitude.

positions of OB . If the two vectors OB and OA happen to have equal magnitudes as they go through phase opposition the successive positions and values of the resultant vector are as shown in Fig. 35; for this con-

dition when the two vectors are 180° out of phase the resultant vector is zero.

It is quite possible so to adjust the tuning of the two circuits that the vector OB is greater than OA at the start of the oscillations; then as the oscillations continue, OB , having greater damping than OA , will become equal to OA and then smaller. Hence in three successive beats it is possible to have the resultant vector OR go through phase changes as depicted in Figs. 33, 34 and 35, respectively, as the amplitudes of the actual current goes through its minimum values. The effects of these peculiar angular velocities of the resultant vector, in combination with its changes in magnitude, account for the peculiar form of the actual current during the one or two cycles of minimum amplitude. It is seen in Figs. 27 and 29 that the 180° phase shift which occurs at the point of minimum amplitude may be produced by either a gain of 180° or a loss of 180° at this time. Fig. 27 shows a loss and Fig. 29 a gain of nearly 180° during the time shown in those curves.

Frequency of Beats.—The beats are not well pronounced unless the two circuits are tuned to the same natural frequency; in this case all of the energy surges back and forth from one circuit to the other. With untuned circuits only a part of the energy is exchanged between the two, most of it remaining in the primary circuit; in this case the beats are not so pronounced as for the tuned circuits, because it is really the to-and-fro flow of the energy which gives the beats

In the case of tuned circuits the two frequencies are given by Eqs. (44) and (45),

$$\omega'' = \omega \left(\frac{1}{\sqrt{1-k}} \right) \text{ and } \omega' = \omega \left(\frac{1}{\sqrt{1+k}} \right).$$

Hence

$$\omega'' - \omega' = \omega \left(\frac{1}{\sqrt{1-k}} - \frac{1}{\sqrt{1+k}} \right) \cong \omega k. \quad \dots \dots (74)$$

This holds, of course, for low values of k only.

As the number of beats per second is equal to the difference in frequency per second of the two component frequencies, we must have the number of beats per second which are given by the relation $N = f k$.

We have shown previously that the frequency of the complex current for tuned circuits (except at the minimum amplitude point) is f . The number of cycles of current per beat is therefore obtained from Eq. (74) by writing,

$$N = f'' - f' = f k,$$

where $N =$ beats per second. From this, we get

$$\frac{f}{N} = \frac{1}{k}. \quad \dots \dots \dots (75)$$

This equation is useful in determining the coupling of a pair of circuits from the shape of the complex wave of current. Thus if there is one beat for five cycles of current the coupling must be 20 per cent.

Form of Secondary Current if Primary Circuit is Opened at the Right Time.—The two circuits of Fig. 16 are used in practically every radio spark transmitting set; the condenser C_2 is, in the actual sets, the capacity of the antenna and part of the resistance, R_2 is the radiation resistance of the antenna. From the foregoing analysis of the current in circuit 2 it is evident that two wave lengths, λ'' and λ' , would be radiated from the antenna; this is undesirable both from the standpoint of efficiency and interference, this latter factor being so important that government license will be granted only to those stations in which such precautions have been taken that practically all their power is radiated in one wave.

As previously stated, all the energy (to be transformed into oscillatory power) is originally stored in condenser C_1 ; when the switch S is closed this electric energy starts surging back and forth from L_1 to C_1 and also starts to flow over to circuit 2. If the two circuits are properly tuned all of the energy will have been transferred to circuit 2 in $\frac{1}{2k}$ cycles; unless prevented from doing so the energy then starts to flow back to circuit 1. Suppose, however, that circuit 1 is opened by some device or other, at that instant when all of its energy has been transferred to circuit 2; the retransfer of the energy to circuit 1 is made impossible because no current can flow in circuit 1 if it is open.

Such an action is accomplished by a "quenched" spark gap to be described in detail in Chapter V. The forms of current in the primary and secondary circuit for this case are as indicated in Fig. 36; the curves are drawn for a coupling of 20 per cent. The number of cycles per beat for such a coupling is five; hence the time $A-B$ during which energy is being transferred to the secondary (being one-half the time of a beat) will be $2\frac{1}{2}$ cycles. At time B the primary circuit is opened and from this time on the secondary circuit oscillates just as if the primary circuit was not present; in fact, electrically, circuit 1 is not present, it being open at the spark gap after time $A-B$.

The form of the current in the secondary circuit during time $A-B$ will approximate that given by Eq. (73); this equation is not strictly applicable because of the variable resistance (spark gap) in circuit 1. However, the resistance of the spark gap is probably negligible compared to the resistance due to the coupling of circuit 2 to circuit 1, so that Eq. (73) closely represents the form of current during time $A-B$. After time B circuit 1 is disconnected (by the opening of the spark gap) and the equation of secondary current is fixed by Eq. (11), the frequency and damping of the current being fixed by the secondary constants only.

The proper value of E to put in Eq. (11) is very nearly equal to

$$E\sqrt{\frac{L_2}{L_1}}e^{-\frac{\alpha_1 + \alpha_2}{2}t'}$$

where E is the voltage of condenser C_1 when discharge began,

$$\alpha_1 = \frac{R_1}{2L_1}, \alpha_2 = \frac{R_2}{2L_2}, \text{ and } t' = \text{time } A-B.$$

With the conditions as represented in Fig. 36 the current in circuit 2 (except for the first one or two alternations) is of frequency f , the natural frequency of circuit 2, and the power is practically all radiated at this one frequency.

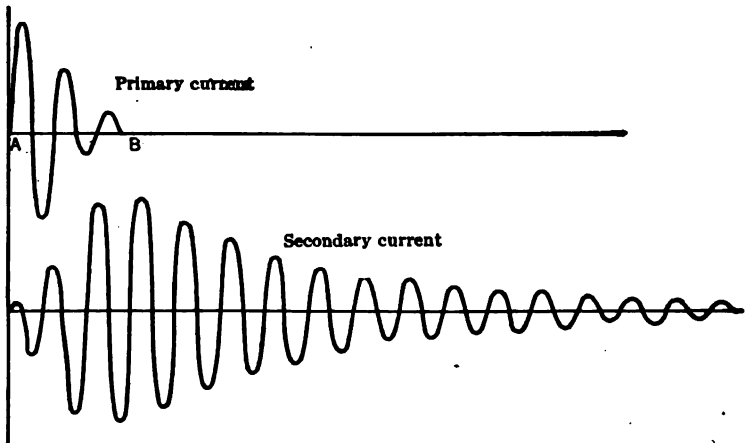

FIG. 36.—Forms of primary and secondary currents if primary circuit is opened at the first minimum.

Possibility of No Beats without a Quenching Gap.—If the damping of the circuits is high and coupling is loose the beating phenomena will be absent, even if the spark gap in the primary does not offer any quenching action. This is illustrated by Fig. 37, in which oscillograms of primary and secondary current are shown for the circuit of Fig. 16, there being no spark gap at all in the primary circuit. The two circuits were tuned alike, the coupling was weak, $k = .07$, and the decrement of each circuit was high, $\delta_1 = \delta_2 = .30$.

This method of getting a current in the secondary of essentially single frequency is of no use to the radio engineer, because it really means that most of the energy originally stored in C_1 is dissipated as heat in the primary circuit; but little power is supplied to the secondary circuit where it is needed to carry out the useful function of radiation.

Oscillatory Discharge in One Circuit and Non-Oscillatory Discharge in the Other.—Under exceptional conditions it is possible with coupled circuits to have a non-oscillatory discharge in one circuit and an oscillatory discharge in the other. If the primary circuit has a high decrement and the secondary circuit a comparatively low decrement then when the primary condenser discharges there may be a single, unidirectional pulse in the primary during which some of the primary energy is transferred to the secondary and some of it used as heat in the primary. Such a scheme is frequently used in small radio sets, and goes by the name of "impulse excitation." The primary circuit has generally a high decre-

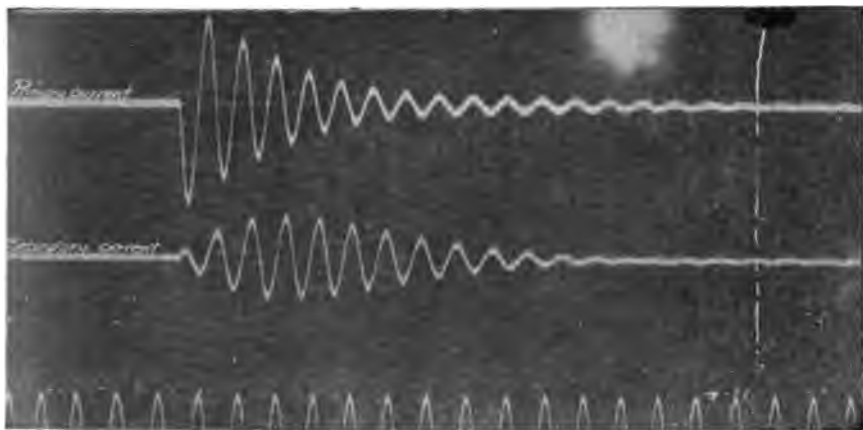

FIG. 37.—Forms of currents in coupled tuned circuits when the coupling is weak and damping is high.

ment, having a large condenser and only one or two turns in its inductance. This gives a high value to $\frac{R}{2fL}$, especially when the resistance of the spark gap is taken into account. In addition to the high primary decrement, the gaps used in this method of generating oscillations are of the quenching type so that when they are functioning properly but one pulse exists in the primary and the secondary is left free to oscillate at its own period and its own decrement.

Oscillatory Circuit Excited by Continuous Voltage.—In case a circuit of L , C , and R , in series is connected to a source of continuous voltage E , Fig. 38, the equation of reactions is

$$E = L \frac{di}{dt} + Ri + \frac{q}{C} \dots \dots \dots (76)$$

By differentiating once this equation becomes the same as Eq. (1), and so its solution must be the same. The same three cases are to be con-

sidered here as they were for Eq. (1); the more important one of the solutions being that of Eq. (11). The initial and final conditions of the problems are different than those considered previously. Evidently at $t=0$, $v_c=0$ and at $t=\infty$, $v_c=E$; these conditions affect the equation of voltage across the condenser terminals, which becomes approximately,

$$v_c = E \left(1 - \epsilon \frac{Rt}{\sqrt{2L}} \cos \frac{t}{\sqrt{LC}} \right). \quad \dots \quad (77)$$

This equation brings out the interesting fact that the maximum voltage across the condenser in such a circuit as that given in Fig. 38 is nearly double that of the source of e.m.f. to which the circuit is connected. This

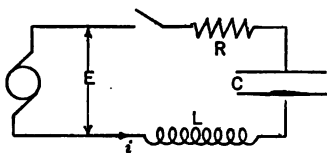

FIG. 38.—Oscillatory circuit connected to a source of continuous-current power.

is illustrated by the film shown in Fig. 39; the voltage of the c.c. line to which the circuit was connected was 105 volts, whereas the maximum potential difference across the condenser was 190 volts. It is evident from this oscillogram that if the dielectric strength of a condenser is to be tested

by connecting it to a source of continuous e.m.f., a resistance should be used in series with the condenser of sufficient magnitude to make the circuit aperiodic. If this is not done the maximum voltage across the condenser is not E , the voltage of the line used for testing, but is equal to $E(1 + \epsilon \frac{\delta}{2})$, where δ is the decrement of the circuit.

Oscillatory Circuit Excited by Energy Stored in Inductance.—In certain radio-testing circuits oscillations are produced not by the energy stored in a condenser but by the energy in the magnetic field of the inductance. The circuit is indicated in Fig. 40; in the actual testing set the battery circuit is made and broken many times a second, perhaps 1000, the function of the switch being performed by the contact points of a small buzzer. When the switch S is closed the condenser C charges at once to battery voltage and the current through L and R rises on a logarithmic curve—Eq. (10), p. 32, to a value E/R , the magnetic energy in the coil being $\frac{LE^2}{2R^2}$. When the switch is opened this magnetic energy is emptied into the condenser C , and then the energy surges back into L as described in the first paragraph of this chapter.

At the end of the first quarter of a cycle of the oscillation all the energy from the coil is in the condenser; it is then charged to such a potential



Fig. 39.—Oscillogram of current and voltages of the circuit shown in Fig. 38.

difference E' that we have (if the decrement of the circuit is so low that the damping for one-quarter of a cycle may be neglected),

$$\frac{CE'^2}{2} = \frac{CE^2}{2} + \frac{LE^2}{2R^2} = E^2 \left(\frac{C}{2} + \frac{L}{2R^2} \right),$$

or

$$E' = E \sqrt{1 + \frac{L}{CR^2}} \dots \dots \dots (78)$$

The cycle of events in such a circuit as shown in Fig. 40 is shown in the film of Fig. 41; of course, all the constants of the circuit used in getting this film are much greater than those used in the so-called "buzzer wave-generator" used in radio, but the form of voltages and currents are nearly the same as those occurring in the radio circuit.

Oscillating Circuits Excited by being Connected to a Line of Alternating e.m.f.—If a circuit of L , R , and C , in series, Fig. 42, is suddenly

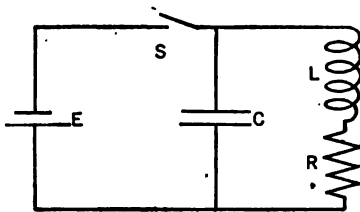

FIG. 40.—Oscillatory circuit to be excited by stored magnetic energy. This circuit is the same as used for "buzzer excitation" of radio circuits.

switched to an alternating current line, the current must be zero, no matter at what point the e.m.f. wave the switch is closed; in general, the condenser of the circuit will not be charged. Now in the steady state the current must have a certain value for any given value of e.m.f. as fixed by Eqs. (35) and (36) of Chapter I. Also the condenser must have a definite charge for this value of impressed e.m.f. It is evident,

therefore, that in general the initial conditions, when the switch is closed, will not satisfy the conditions required by the steady state.

For this reason the current for the first few cycles after switching the circuit to the line will be of irregular form; the circuit requires time to "settle down" to the steady state. Mathematically this is accomplished by adding to the equation for the steady current a suitable damped oscillation, the magnitude of which depends upon the time the switch is closed and the frequency of which is fixed by the L and C of the circuit.

The actual current after closing the switch is therefore the sum of the steady value of current and a damped oscillation at the natural period of the circuit, the two sufficing to satisfy the required initial conditions on closing the switch.

If the impressed voltage is $e = E \sin pt$, the circuit having constants, L , C and R and $\left(\frac{R}{2L}\right)^2 < \frac{1}{LC}$ the solution is,

$$i = A e^{-\alpha t'} \sin(\omega t') + \frac{E}{\sqrt{R^2 + \left(pL - \frac{1}{pC}\right)^2}} \sin(pt - \phi), \dots (79)$$



Fig. 41.—Oscillogram of current and voltages in circuit of Fig. 40.

in which

$$\tan \phi = \left(pL - \frac{1}{pC} \right) / R,$$

$$\alpha = \frac{R}{2L} \text{ and } \omega = \sqrt{\frac{1}{LC}}, \text{ approximately,}$$

and t' is the time counted from the start of the supposititious transient oscillatory current; it is sometimes written $(t + \Delta t)$ where Δt is the time between the start of the supposititious transient term and the closing of the switch—this increment of time is indicated in Fig. 44.

A and t' are to be suitably determined to satisfy the initial condition that $i=0$ and $v_c=0$. This condition, $v_c=0$, supposes the condenser to be uncharged at the time of switching the circuit to the line; if it is charged to a certain potential difference V , then the initial conditions are $i=0, v_c=V$.

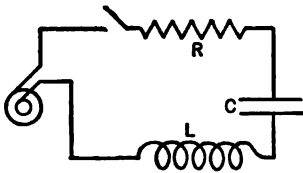

FIG. 42.—Oscillatory circuit to be connected to source of alternating-current power.

Let us suppose the steady state of the circuit is as represented in Fig. 43, and further let us suppose that the switch is closed at the phase indicated by θ . In the steady state the current should be I' and the voltage across the condenser should be

V' . Actually the current at the time of closing the switch is zero, and we also suppose an uncharged condenser, so that $v_c=0$. We must then determine t' and A of Eq. (79) that these initial conditions are satisfied.

The equation for voltage across the condenser, due to the transient term only, we write,

$$v_c = E_0 \epsilon^{-\alpha t'} \cos \omega t', \quad \dots \dots \dots (80)$$

and hence, the current due to the transient term is,

$$i = C \frac{dv_c}{dt} = -\omega C E_0 \epsilon^{-\alpha t'} \sin \omega t' - \alpha C E_0 \epsilon^{-\alpha t'} \cos \omega t'.$$

We here make the same assumption we have previously made for similar circuits, that α is negligible compared to ω , and so we get,

$$i = -\omega C E_0 \epsilon^{-\alpha t'} \sin \omega t'. \quad \dots \dots \dots (81)$$

Using the condition that the voltage across the condenser must be zero at the time of closing the switch, we have

$$v_c + V' = 0 \text{ or } -V' = \epsilon^{-\alpha t'} E_0 \cos \omega t'_0,$$

in which t'_0 is the value of t' when the switch is closed.

Then

$$E_0 = -\frac{V'}{\epsilon^{-\alpha t'_0} \cos \omega t'_0} \dots \dots \dots (82)$$

Also,

$i + I' = 0$, so from (81) using also (82)

$$I' = - \frac{\omega CV' \epsilon^{-\alpha t_0} \sin \omega t_0'}{\epsilon^{-\alpha t_0} \cos \omega t_0'}$$

or

$$\tan \omega t_0' = - \frac{I'}{\omega CV'} \dots \dots \dots (83)$$

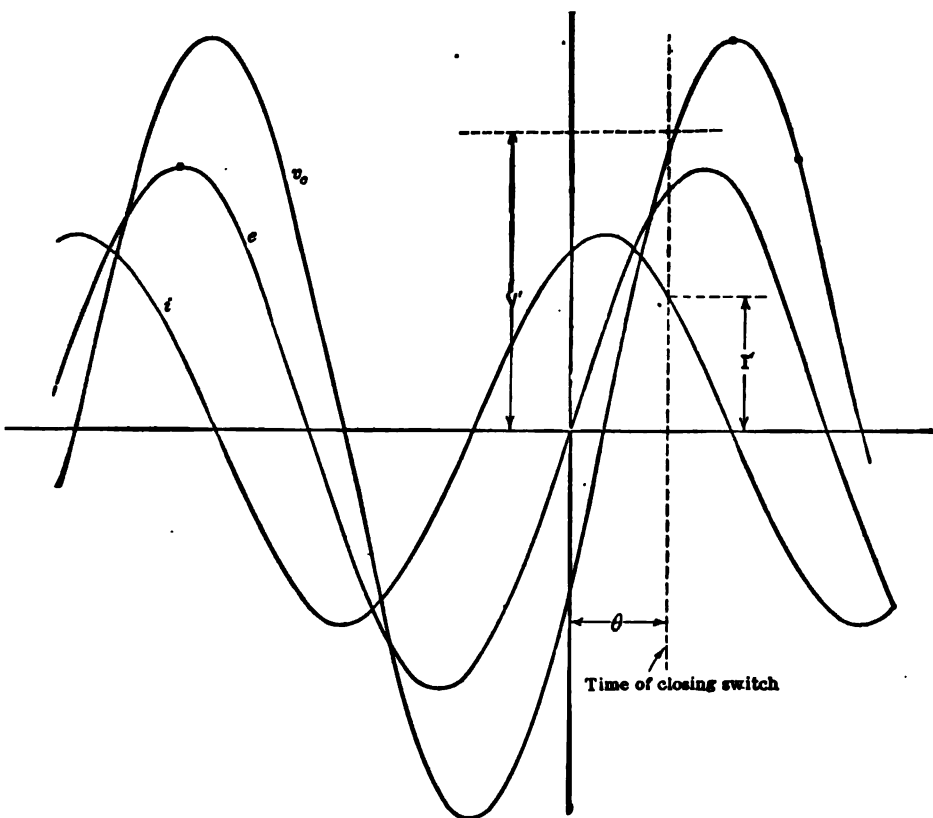

FIG. 43.—Proper “steady state” values of voltages and current of circuit of Fig. 42, at time of closing switch.

In case the damping of the circuit is small this equation may be written

$$\tan \omega t_0' = - \frac{I'}{V'} \sqrt{\frac{L}{C}}$$

From this equation we get $\tan \omega t_0'$ and so may find the value of $\cos \omega t_0'$. Knowing $\omega t_0'$ and ω we get t_0' and so can calculate $\epsilon^{-\alpha t_0'}$ and then substituting in (82), we get E_0 ; evidently $A = -\omega CE_0$, which can now be substituted in Eq. (79).

In Fig. 44 are reproduced in dotted lines the current and voltage curves of Fig. 43 and in dashed lines the transient current and condenser voltage determined from Eqs. (83) and (82) and (81). The addition of

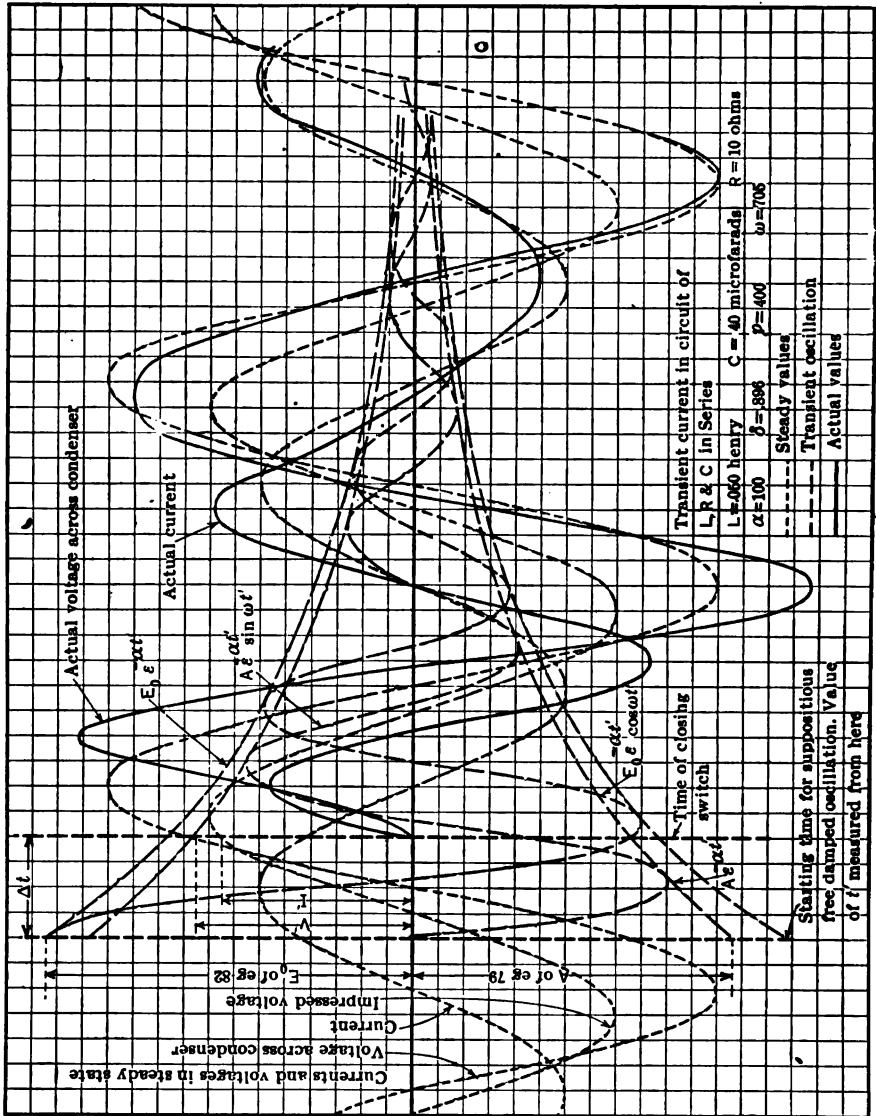

FIG. 44.—Analysis of the transient condition existing after closing the switch of circuit shown in Fig. 42.

the steady value of current and the transient current gives the full line curve which is the actual current in the circuit after closing the switch.

In Fig. 45 is shown an oscillogram of the transient current after switching such a circuit as the one used in plotting the curves of Fig. 44. From

Figs. 44 and 45 it may be seen that on switching a circuit, of L , R , and C , in series, to an alternating current line the condenser might be subjected to much higher voltages than occur in the steady state, nearly twice as much if the damping is low.

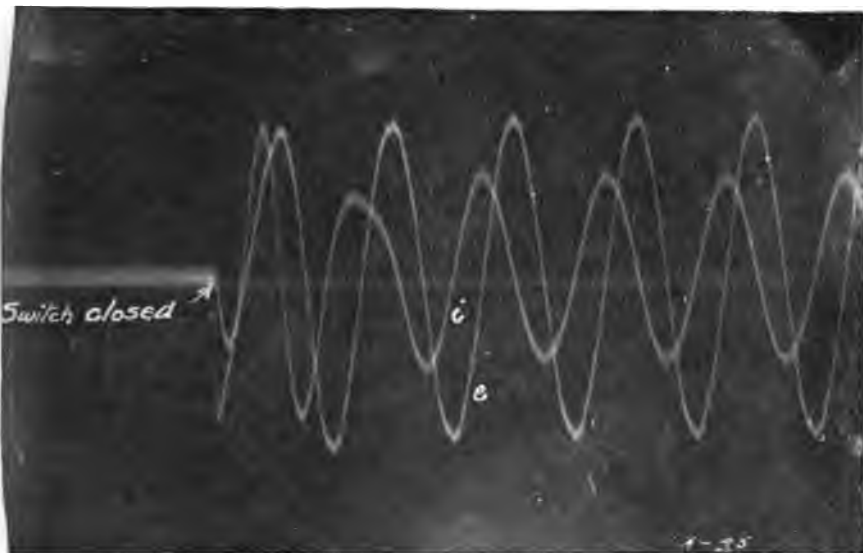

FIG. 45.—Oscillogram of transient current corresponding to condition shown in Fig. 44.

Periodic Disturbances in a Resonant Circuit.—In every radio spark set there is a circuit the equivalent of that shown in Fig. 46; in place of the switch shown there is a spark gap which performs the same function. An alternator supplies power to a condenser C , through a transformer T ;

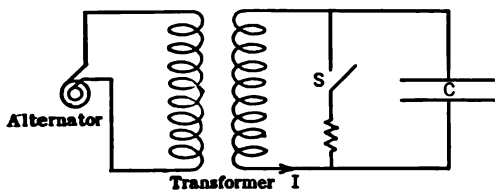

FIG. 46.—Elementary circuit illustrating the action occurring in every spark set when the spark gap breaks down.

once every cycle (or alternation) the condenser is short circuited for a very short time, in an actual set by the spark gap breaking down, in the set from which the following oscillograms were taken, by a suitable revolving switch. The time of switch closure was adjusted for maximum voltage in the secondary circuit

and took place at the same phase of each cycle. The voltage across the condenser and current in the secondary of the transformer for this case have been worked out theoretically, but they are rather

unwieldy, as one might suppose after an elementary consideration of the problem.¹

For each closure of the switch S , a transient term is introduced into the circuit, and as the damping is not sufficient to eliminate one transient before another is introduced, the actual current and voltage consist of the steady values with a whole series of transients superimposed. The form of voltage and current depend largely upon the ratio of the frequency of the impressed e.m.f. to the natural frequency of the circuit.

In Figs. 47, 48, and 49 are shown the forms of voltage across the condenser and current in the secondary of the transformer for three values

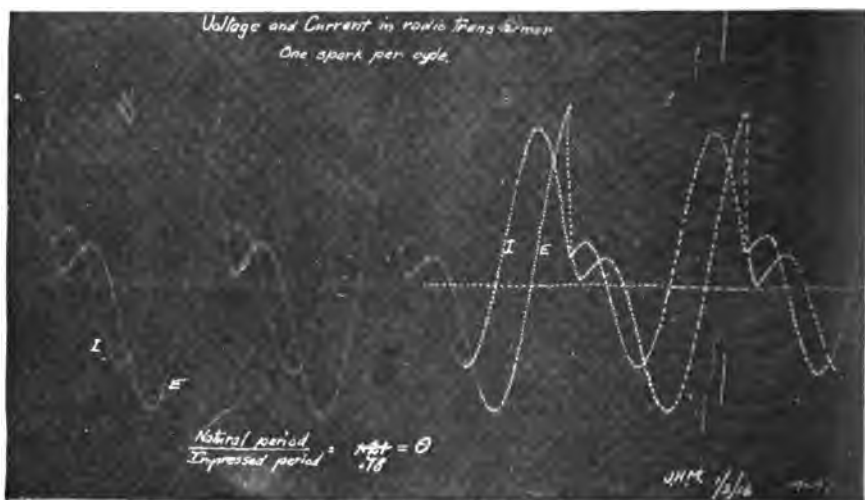

FIG. 47.—Voltage and current in such a circuit as that shown in Fig. 46, the switch S being closed synchronously. Natural frequency of secondary circuit greater than alternative frequency.

of this ratio. In Fig. 47 the natural period was less than that of the alternator, in Fig. 48, the two were equal, and in Fig. 49, the natural period was greater than that of the alternator. As the films were taken at high speed they are not very distinct, so two cycles have been dotted in with ink.

It will be seen at once that any mathematical expression to represent these curves must be a complex one. With the switch adjusted to make one closure per cycle the circuit is a rectifying one; if the voltage across the condenser at the time of short circuit is E it is evident that each cycle

¹ Fulton Cutting, "The theory and design of Radio Telegraphic Transformers," Proc. I. R. E., Vol. 4, No. 2, April, 1916. This article serves to show how complicated an exact treatment may become; in Chapter V, p. 307-8, are shown some curves which are calculated from simpler formulæ, which curves represent quite accurately the form of disturbance in the ordinary spark transmitting set.

the secondary of the transformer carries more in one direction than it does in the other a quantity of electricity equal to CE .

Oscillating Circuit Excited by Pulse.—It often occurs in radio work that an oscillatory circuit is excited by a unidirectional pulse of some

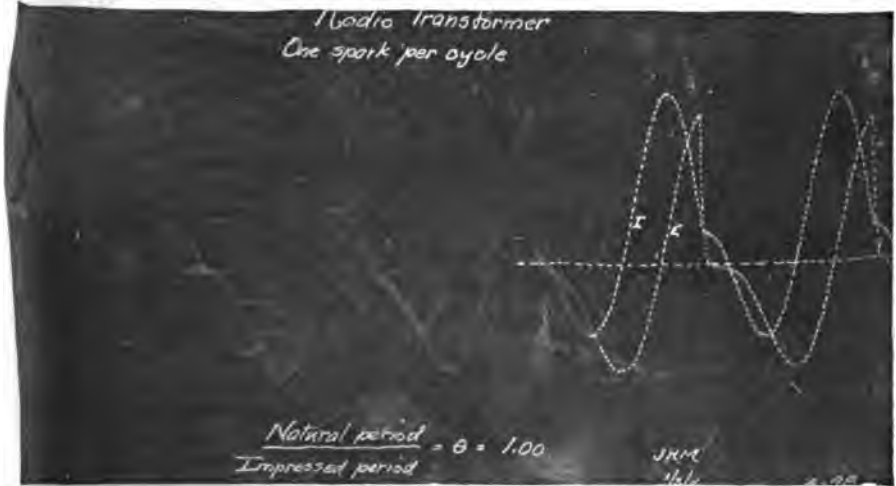

FIG. 48.—Similar to Fig. 47 but with secondary circuit having a natural frequency equal to that of the alternator.

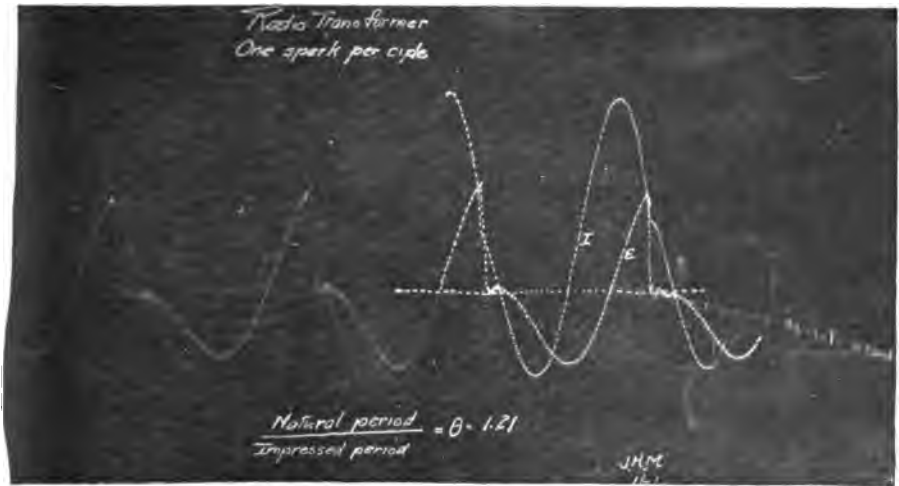

FIG. 49.—Similar to Fig. 47 but with secondary circuit having a natural frequency less than that of the alternator.

shape or other; thus it is quite likely that atmospheric disturbances in radio receiving circuits are due to some sort of highly damped oscillation or a series of short pulses. The effect of a pulse on a resonant circuit

will depend upon two factors, the ratio of the duration of the pulse to the natural period of the circuit, and the intensity or amplitude of the pulse. Also to a minor extent the exact form of the pulse will determine the amount of disturbance produced.

The simplest kind of a pulse to consider mathematically is a "square" pulse, one in which the voltage rises suddenly from zero to a certain value, holds this value for a short time and then again drops suddenly to zero. If such a pulse of voltage is introduced into a circuit consistent of L , C , and R , in series the shape of the current can be obtained by properly combining the solutions of Eqs. (76) and (1). Eq. (76) gives the conditions when the voltage is applied to the circuit and Eq. (77) gives the voltage on the condenser at any time to after the voltage has been applied. When the pulse of voltage ends, Eq. (1) applies, the voltage on the discharging condenser being that determined from Eq. (77).

Thus in Fig. 50 is shown at a the pulse of e.m.f. introduced into the oscillating circuit, in b is shown in full lines the condenser voltage curve, determined from Eq. (77) and in the dotted line the current produced in the circuit by the introduction of voltage E .

Counting $t=0$ at the beginning of the pulse, we have

$$i = \frac{E}{\omega L} \epsilon^{-\alpha t} \sin \omega t, \tag{84}$$

and

$$v_c = E(1 - \epsilon^{-\alpha t} \cos \omega t), \tag{85}$$

in which $\omega = \frac{1}{\sqrt{LC}}$ and $\alpha = \frac{R}{2L}$, the solution being approximate as α has been considered small compared to ω .

If the pulse has a duration, T , at the end of the pulse the voltage in the condenser is

$$v_c = E(1 - \epsilon^{-\alpha T} \cos \omega T). \tag{86}$$

Now at the end of the pulse the solution of Eq. (1) is available if we substitute the proper initial conditions. The circuit solved in Eq. (1) was one in which the initial conditions were a charged condenser and the zero current. By inspection of Eqs. (86) and (84) it is evident that if we make $T = \frac{\pi}{\omega}$ the current at the end of the pulse is zero ($\sin \omega T = 0$) and the voltage in the condenser is $v_c = E(1 + \epsilon^{-\alpha T})$, as $\cos \omega T = -1$.

The equation for current from the end of the pulse (for length of pulse $= \pi/\omega$) is therefore,

$$i = -\frac{E}{\omega L} \left(1 + \epsilon^{-\frac{\delta}{2}}\right) \epsilon^{-\alpha t'} \sin \omega t'$$

where t' is reckoned after the end of the pulse. This current is shown in curve c , Fig. 50. At time $t' = \frac{\pi}{2\omega}$, $\sin \omega t' = 1$ and the value of current is

$$I_{\max.} = -\frac{E}{\omega L} \left(\epsilon^{-\frac{t}{\tau}} + \epsilon^{-\frac{3t}{\tau}} \right) \dots \dots \dots (87)$$

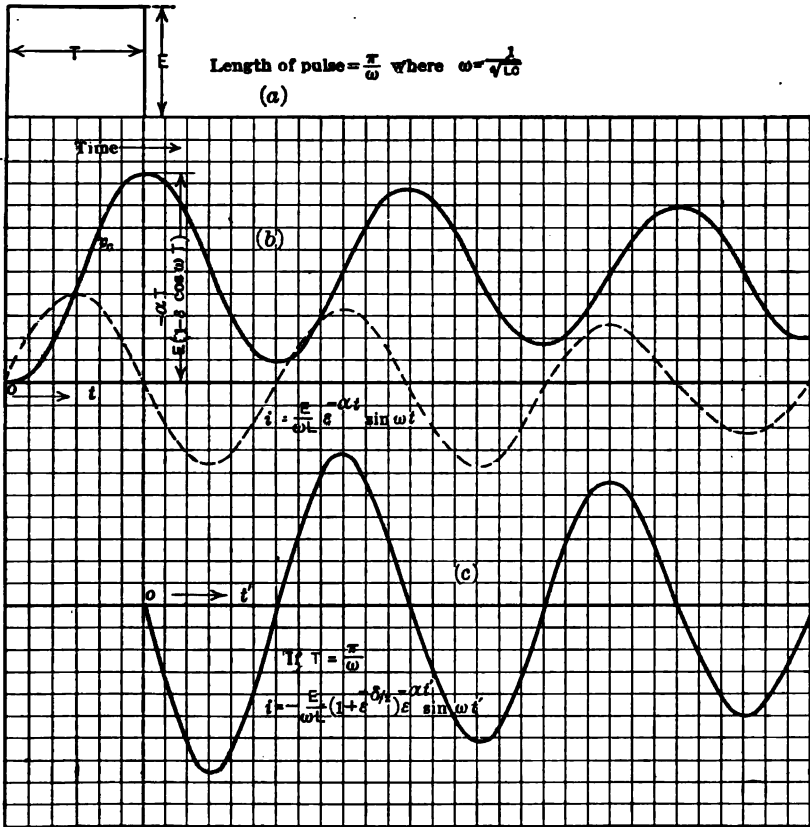

FIG. 50.—Effect of introducing a rectangular pulse of e.m.f. into an oscillatory circuit.

This is the maximum current obtainable from a rectangular pulse, of amplitude E , no matter what its duration may be. Any duration either more or less than π/ω will give less value to $I_{\max.}$

A more fundamental way of looking at the problem is to consider a voltage of $+E$ impressed on the circuit at the beginning of the pulse, and that this voltage is maintained; at the end of the pulse a voltage of $-E$ is impressed on the circuit and maintained. Each of the impressed voltages will produce a current, and the actual current at any time is the sum of the two.

The current after the second voltage ($-E$) is impressed

$$i = +\frac{E}{\omega L}\epsilon^{-\alpha t}\sin \omega t - \frac{E}{\omega L}\epsilon^{-\alpha t'}\sin \omega t',$$

in which t is the time after the ($+E$) voltage is impressed and t' is the time after the second voltage ($-E$) is impressed. If the interval between the application of these two voltages is T_0 , then the current after time T_0 has passed is

$$i = -\frac{E}{\omega L}\{\epsilon^{-\alpha t'}\sin \omega t' - \epsilon^{-\alpha(t'+T_0)}\sin \omega(t'+T_0)\}.$$

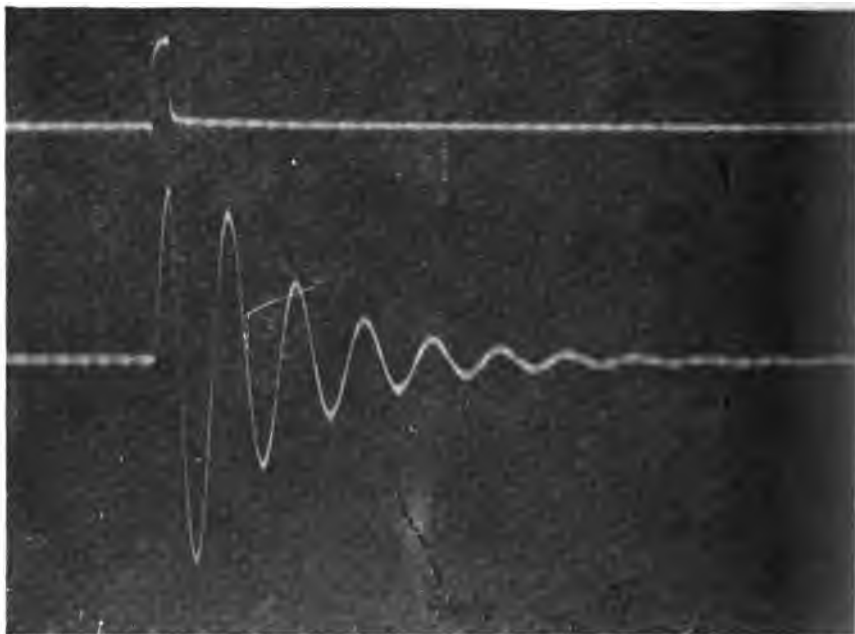

FIG. 51.—Oscillogram of oscillatory current produced by short pulse of e.m.f.

If the damping is comparatively small, the maximum current will occur when $\sin \omega t'$, and $\sin \omega(t'+T_0)$ are simultaneously equal to unity and of opposite sign. Moreover, it is evident that, because of the damping factors, this maximum current will have its greatest value when the above conditions occur for the smallest possible value of $\omega t'$. Inspection shows this to be when $\omega t' = \pi/2$ and $\omega T_0 = \pi$; this means that the length of the pulse (time between applying $+E$ and $-E$) should be equal to one-half the natural period of the circuit and the maximum current occurs one-quarter of a period after the end of the pulse. Putting $T_0 = T/2$

(T being the natural period of the circuit), the equation for current becomes

$$i = -\frac{E}{\omega L}(\epsilon^{-\alpha t'} + \epsilon^{-\alpha(t'+\frac{T}{2})}) \sin \omega t',$$

and if we now suppose $\omega t' = \pi/2$ and write the damping in terms of decrement, we get

$$I (\text{maximum}) = -\frac{E}{\omega L}(\epsilon^{-\frac{\delta}{4}} + \epsilon^{-\frac{3\delta}{4}}).$$

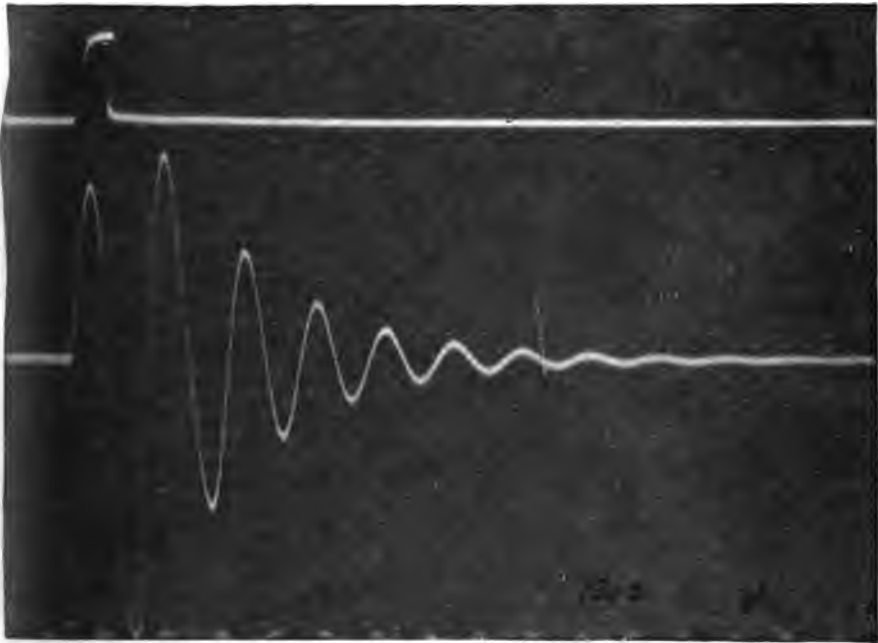

FIG. 52.—Similar to Fig. 51 but with longer pulse.

An oscillographic investigation of impulse excitation was carried out by the author¹ and some of the films obtained are shown in Figs. 51, 52, and 53. The upper record of the films shows the shape and length of pulse of e.m.f. introduced into the oscillatory circuit and the lower curve shows the current set up in the circuit by the pulse. A complete set of films was taken varying the length of pulse from less than 0.2 of the natural period of the circuit to several times the period. The amplitude of the first and second alternations were measured and their values plotted in terms of the ratio of pulse length to natural period of the circuit; the

¹ Proc. I. R. E., Vol. 8, No. 1, February, 1920.

results are given in Fig. 54 and it is seen that the results are in accord with the prediction of Eq. (87).

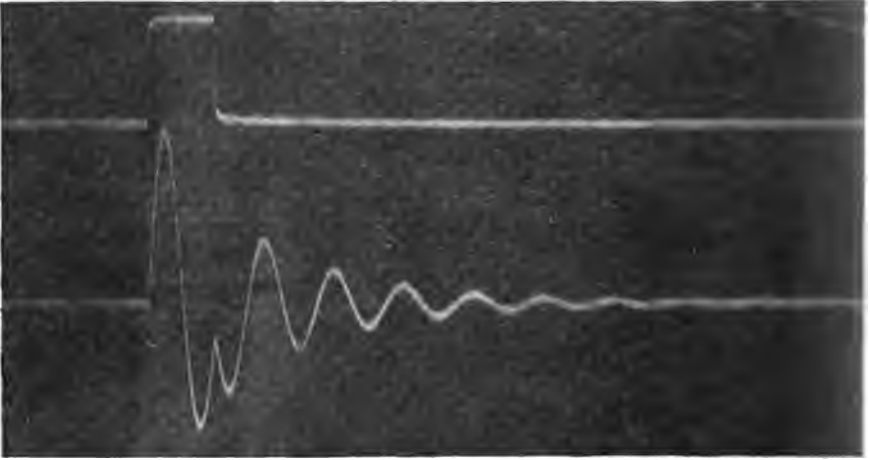

FIG. 53.—Similar to Fig. 52 but with longer pulse.

In case a series of irregularly timed pulses are impressed on an oscillatory circuit the resulting current will be of rather complex form; Figs. 55 and 56 show how such irregular pulses excite an oscillatory circuit.

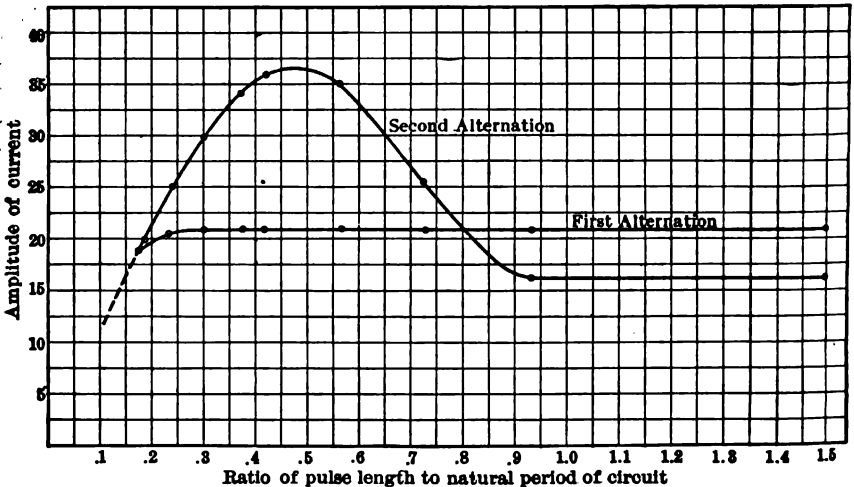

FIG. 54.—Variation in amplitude of oscillatory current with length of pulse.

It is evident (Fig. 55) that pulses properly timed may practically neutralize one another as in this case the circuit was nearly dead after the last pulse.



FIG. 55.—Irregular current produced by series of pulses.

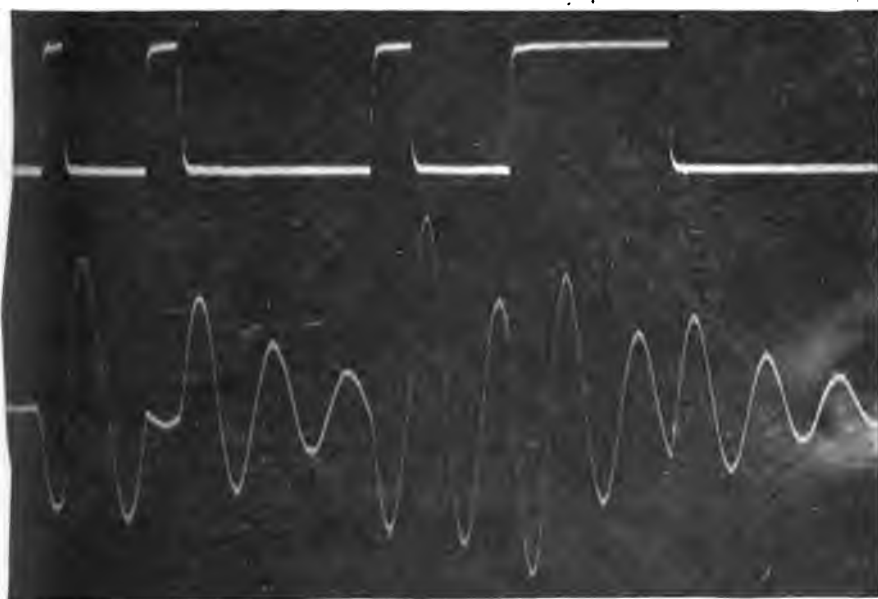

FIG. 56.—Irregular current produced by series of pulses.

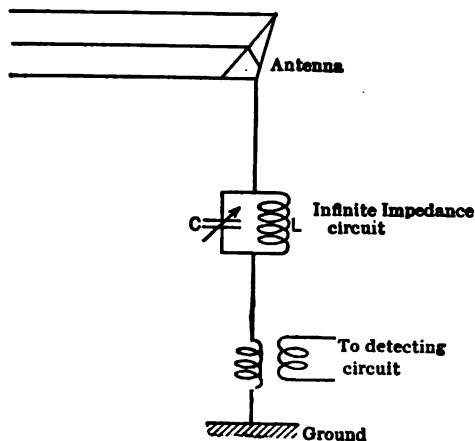

FIG. 57.—Showing the use of a parallel resonant circuit for weeding out undesired signals from an antenna. Such a parallel circuit is often called an "infinite impedance."

and so predicts nothing regarding the behavior of the circuit for other than steady alternating voltages; even in this case the equations are good only if the e.m.f. has been applied sufficient time for the transient terms to disappear.

Because of the "infinite impedance" characteristic the circuit is often used to eliminate from a circuit some undesired frequency; thus in Fig. 57 the L - C parallel circuit is so adjusted that its natural period is the same as that of some undesired frequency which is impressed on the antenna. Now it is to be remembered that the L - C circuit offers "infinite impedance" only for the steady state and it is interesting to note the impedance offered by it to a pulse of e.m.f.

Impulse Excitation of a Parallel Resonant Circuit.—A condenser and coil in parallel act like a circuit of very high resistance for an e.m.f. of the same frequency as that natural to the circuit. The value of the resistance is predicted by Eq. (48), Chapter I, and curves are shown in Chapter I, Figs. 70 and 71; because of this characteristic the circuit is often called an "infinite impedance" circuit. The Eq. (48) was derived from the steady state of the circuit.

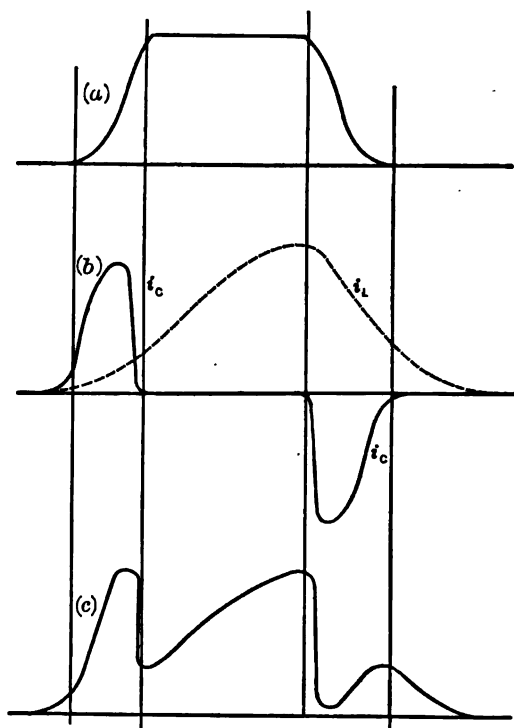

FIG. 58.—Action of an approximately rectangular pulse of e.m.f. impressed across (a) parallel circuit-curves in (b) show the separate currents, the total current being that shown at (c).

If the pulse is a square one, such as used in Figs. 50–53, the current flowing in the supply line (the impedance of the circuit other than that of the “infinite impedance” being neglected) will be about as shown in Fig. 58. The e.m.f. pulse form is shown in curve *a*; the full line curve of *b* shows the current flowing through the condenser and the dotted line that through the coil; in *c* is shown the actual current in the line, that is, the current which the “infinite impedance” circuit lets through. These curves, as mentioned before, are drawn on the assumption that the impedance of the rest of the circuit is negligible.

It would seem likely that if the circuit does have such a very high impedance for a certain frequency then it will offer a high impedance to a pulse, if this pulse is in the form of one alternation of a sine wave as that natural to the circuit. Fig. 59 shows the analysis of this case; *a* shows the form of pulse $e = E \sin \omega t$ (holding only between $\omega t = 0$ and $\omega t = \pi$); the curves of *b*

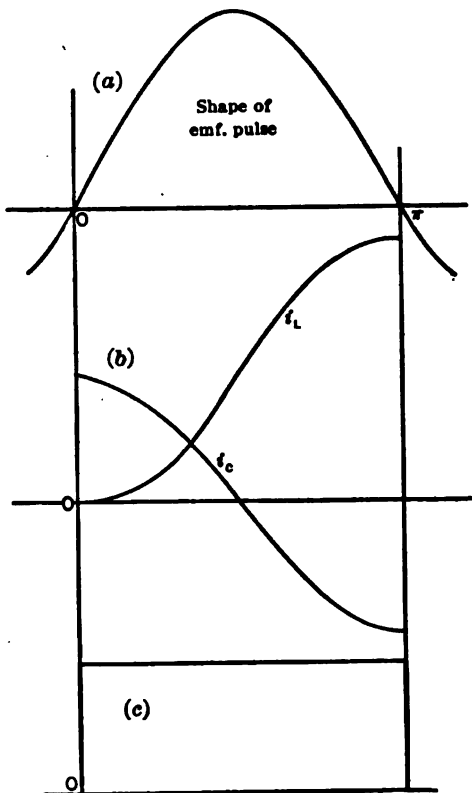

Fig. 59.—Effect of impressing a sinusoidal pulse of e.m.f. across a parallel circuit.

indicate the currents through each branch, and curve *c* shows the current passed by the combined circuit. As the resistance in the parallel path is made to approach zero this line current approaches a true rectangular form, i.e., current of constant magnitude and equal to $2\pi fCE$, where f is the frequency of the e.m.f. of which the pulse is the alternation.

Analyzed mathematically, we have

$$i_C = \omega CE \cos \omega t$$

and

$$i_L = E \left(\frac{R}{R^2 + (\omega L)^2} \sin \omega t - \frac{\omega L}{R^2 + (\omega L)^2} \cos \omega t + \frac{\omega L}{R^2 + (\omega L)^2} e^{-\frac{R\omega t}{L}} \right),$$

this being derived as a special case of Eq. (79).

For a good coil, i.e., one having a high value for $\frac{\omega L}{R}$, we have as an approximate value,

$$i_L = E \left(\frac{R}{(\omega L)^2} \sin \omega t - \frac{1}{\omega L} \cos \omega t + \frac{1}{\omega L} \epsilon^{-\frac{Rt}{L}} \right).$$

Adding to this the condenser current we get for the current passed by this parallel combination,

$$i = E \left(\frac{R}{(\omega L)^2} \sin \omega t + \left(\omega C - \frac{1}{\omega L} \right) \cos \omega t + \frac{1}{\omega L} \epsilon^{-\frac{Rt}{L}} \right).$$

If now the constants of the circuit are such that $\omega C = \frac{1}{\omega L}$, then

$$i = \frac{E}{\omega L} \left(\frac{R}{\omega L} \sin \omega t + \epsilon^{-\frac{Rt}{L}} \right). \dots \dots \dots (88)$$

Oscillatory Circuit Excited by a Damped Sine Wave.—Let us consider a circuit made of L , R , and C in series as e.g., the ordinary antenna, to be excited by a damped sine wave of voltage such as is induced many

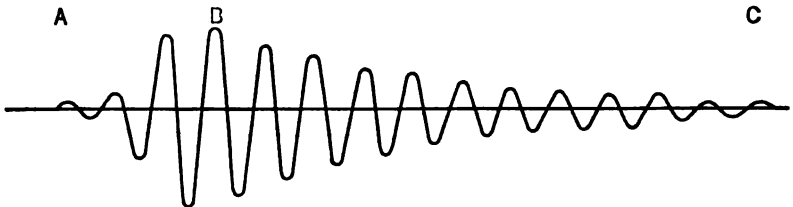

FIG. 60.—Form of voltage induced in a receiving antenna by the passage of one wave train as emitted from the ordinary spark transmitter.

times each second in an antenna by a signal from a distant spark station. The voltage caused in an antenna by every discharge in the transmitting circuit is not exactly representable by a damped sine wave, because for the first few cycles its amplitude is increasing instead of decreasing; this is indicated in Fig. 60, which shows about the form of voltage actually induced in an antenna. The part $A-B$ is relatively short ($2\frac{1}{2}$ cycles for 20 per cent coupling in the transmitting station) and the part $B-C$ is really a damped sine wave represented by $E\epsilon^{-kt} \sin pt$.

The form of current induced in the antenna is determined in the usual way by putting the sum of its reactions equal to the impressed force. —

$$L \frac{di}{dt} + Ri + v = E\epsilon^{-kt} \cos pt, \dots \dots \dots (89)$$

v being the voltage across the condenser.

Writing the impressed force as a cosine function indicates that we are going to consider the case of maximum voltage at $t=0$; such is the case when the circuit we are considering is acted upon by the oscillatory current set up in a neighboring circuit by the discharge of a condenser. Eq. (89) may be written in the form,

$$\frac{d^2v}{dt^2} + 2\alpha \frac{dv}{dt} + (\omega^2 + \alpha^2)v = \frac{E}{LC} \epsilon^{-kt} \cos pt, \quad \dots \quad (90)$$

by using the relations

$$i = C \frac{dv}{dt}, \quad \alpha = \frac{R}{2L}, \quad \text{and} \quad \omega^2 + \alpha^2 = \frac{1}{LC}.$$

Differentiating (89) twice with respect to time and eliminating the right-hand number by multiplying (90) by $(p^2 - k^2)$, its first derived equation by $2k$, and adding both the resulting equations to the second derived equation, we obtain

$$\begin{aligned} \frac{d^4v}{dt^4} + 2(k + \alpha) \frac{d^3v}{dt^3} + [(p^2 + k^2) + (\omega^2 + \alpha^2) + 4\alpha k] \frac{d^2v}{dt^2} \\ + [2\alpha(p^2 + k^2) + 2k(\omega^2 + \alpha^2)] \frac{dv}{dt} + [(p^2 + k^2)(\omega^2 + \alpha^2)]v = 0. \quad \dots \quad (91) \end{aligned}$$

This equation is in standard form for integration, the value of v being of the form

$$v = V_1 \epsilon^{-kt} \sin(pt + \theta) + V_2 \epsilon^{-\alpha t} \sin(\omega t + \phi). \quad \dots \quad (92)$$

From this equation we get

$$i = I_1 \epsilon^{-kt} \sin(pt + \theta') + I_2 \epsilon^{-\alpha t} \sin(\omega t + \phi'). \quad \dots \quad (93)$$

This solution shows that the current flowing in the circuit is made up of two components, one of the same frequency as the impressed force and one of the natural frequency of the circuit.

This might have been surmised from an elementary analysis of the problem. Suppose the damping of the impressed force is zero, then Eq. (79) page 252, would give the correct solution and this has two terms, one of the frequency of the impressed force (which is the solution for the steady state) and the transient term which dies away at a rate fixed by the decrement of the circuit.

The relative amplitudes of the two currents, I_1 and I_2 , will evidently depend in some way upon the relative values of the damping factors, k and α , also upon the relative values of the frequencies fixed by p and ω . By getting the values of v , $\frac{dv}{dt}$, and $\frac{d^2v}{dt^2}$ from (92) and substituting them in (90), we find the value of V_1 to be

$$V_1 = E \frac{\omega^2 + \alpha^2}{\sqrt{[\omega^2 - p^2 + (\alpha - k)^2]^2 + 4p^2(\alpha - k)^2}}, \quad \dots \quad (94)$$

and

$$\tan \theta = \frac{\omega^2 - p^2 + (\alpha - k)^2}{2p(\alpha - k)}.$$

Now by substituting in Eq. (92) the initial conditions that when $t=0$ $v=0$, then differentiating (92) and in this equation putting $\frac{dv}{dt}=0$ when $t=0$ we get the value of V_2 in terms of V_1 . Substituting the value of V_1 from (94), we get,

$$V_2 = E \frac{(\omega^2 + \alpha^2) \sqrt{p^2 + (\alpha - k)^2}}{\omega \sqrt{[\omega^2 - p^2 + (\alpha - k)^2]^2 + 4p^2(\alpha - k)^2}}, \dots \quad (95)$$

and

$$\tan \phi = \frac{\omega}{\alpha - k} \frac{\omega^2 - p^2 + (\alpha - k)^2}{\omega^2 + p^2 + (\alpha - k)^2}.$$

From the values of V_1 and V_2 we find at once I_1 and I_2 by using the relations $I_1 = pCV_1$ and $I_2 = \omega CV_2$:

$$I_1 = E \frac{p}{L \sqrt{[\omega^2 - p^2 + (\alpha - k)^2]^2 + 4p^2(\alpha - k)^2}}, \dots \quad (96)$$

$$I_2 = E \frac{\sqrt{\omega^2 + (\alpha - k)^2}}{L \sqrt{[\omega^2 - p^2 + (\alpha - k)^2]^2 + 4p^2(\alpha - k)^2}}, \dots \quad (97)$$

The values of θ' and ϕ' —Eq. (93)—are determined from the values of θ and ϕ given above, by increasing each of them by $\pi/2$.

The exact form of current in the circuit is now fixed by the values of I_1 , I_2 , k , α , p and ω . It will be evident that if both damping factors are low and nearly equal, and the two frequencies, fixed by p and ω , are nearly equal, the conditions are the same as those for the secondary current in coupled circuits as illustrated in Fig. 26 of this Chapter. If $p = \omega$ there can be no beats; for all values of damping, the current, with frequency $\frac{\omega}{2\pi}$ increases in value from zero to a certain maximum and then decreases again.

An analysis due to Bjerknes¹ shows that this current can be represented by the equation

$$i = mCM \cos (mt + \psi), \dots \quad (98)$$

in which $m = \frac{p + \omega}{2}$ and ψ is the phase of the impressed e.m.f. at time $t=0$.

¹ V. Bjerknes, "Electrical Resonance," Wied. Ann., 1895, Vol. 55.

If we let $n = \frac{p - \omega}{2}$, $a = \frac{k + \alpha}{2}$, $b = \frac{k - \alpha}{2}$, then

$$M = \left(\frac{E}{4mLC}\right)^2 \frac{1}{(n+b)} \left\{ P_1 + 2\left(\frac{1 + \cos 2\psi}{m}\right) P_2 + 2\left(\frac{\sin 2\psi}{m}\right) P_3 \right\}, \quad (99)$$

in which

$$P_1 = e^{-2at}(\epsilon^{-2bt} + \epsilon^{2bt} - 2 \cos nt);$$

$$P_2 = e^{-2at}(n\epsilon^{2bt} - n \cos nt - b \sin 2nt);$$

$$P_3 = e^{-2at}(b\epsilon^{2bt} - b \cos 2nt + n \sin 2nt).$$

In certain cases the form of M is simpler than indicated in Eq. (99).

If $p = \omega$ and $k = \alpha$

$$M = \pm \frac{Et}{2mLC} e^{-at} \dots \dots \dots (100)$$

If $p = \omega$ and $k \neq \alpha$

$$M = \pm \frac{E}{4mbLC} e^{-at}(\epsilon^{-bt} - \epsilon^{bt}) \dots \dots \dots (101)$$

If $p \neq \omega$ and $k = \alpha$

$$M = \pm \frac{E}{2mnLC} e^{-at} \sin nt \dots \dots \dots (102)$$

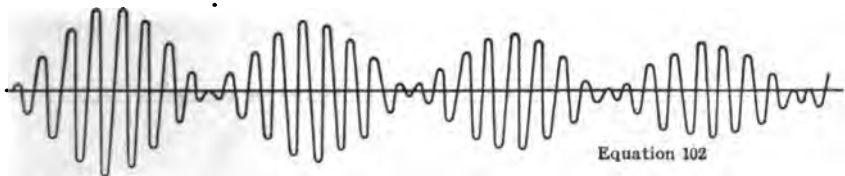
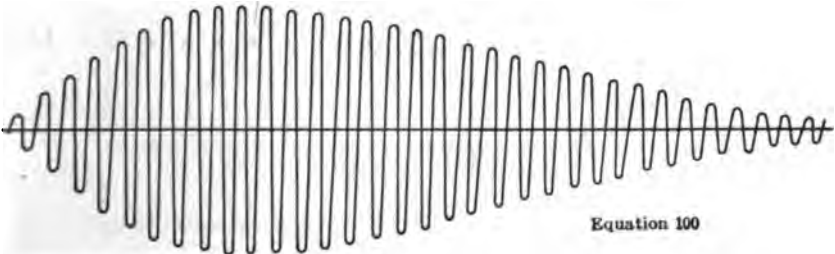

FIG. 61.—Two possible forms of current in the antenna excited by the wave trains from a spark transmitter.

In case neither the damping factors nor frequencies are the same the general form given in Eq. (99) must be used.

In Fig. 61 are shown the forms of current in the oscillatory circuit for the cases given in Eqs. (100) and (102)

Resonance Curve of an Oscillatory Circuit Excited by Damped Sine Waves.—In Chapter I we analyzed the action of an oscillatory circuit (L , C , and R in series) when excited by an alternating e.m.f. of constant amplitude and showed that the form of the curve obtained when either C , L , or f was varied (E being held constant in amplitude), enables us to determine the decrement of the circuit. The form of the resonance curve for the steady state depends only upon the relation between the impedance of the circuit and the frequency of the impressed force. When such a circuit is excited by a damped sine wave the reading of the indicating device for showing resonance will depend on both of the terms in Eq. (93). If a hot-wire ammeter is used to show resonance it is evident that its reading will depend upon the average integral of the square of each of the currents I_1 and I_2 . Bjerknes and others have analyzed the value of this integral and by somewhat lengthy deductions have obtained the relation,

$$I^2 = \frac{E^2}{16L^2} \frac{k + \alpha}{k\alpha} \frac{1}{(p - \omega)^2 - (k + \alpha)^2} \dots \dots \dots (103)$$

At resonance ($\omega = p$) this reduces to,

$$I_r^2 = \frac{E^2}{16L^2} \frac{1}{k\alpha(k + \alpha)} \dots \dots \dots (104)$$

From (103) and (104)

$$\frac{I^2}{I_r^2} = \frac{(k + \alpha)^2}{(p - \omega)^2 + (k + \alpha)^2}$$

so

$$\frac{I_r^2 - I^2}{I^2} = \frac{(p - \omega)^2}{(k + \alpha)^2}$$

From this we get

$$k + \alpha = (p - \omega) \sqrt{\frac{I^2}{I_r^2 - I^2}}$$

If we now introduce the decrements, instead of damping factors, we have, putting $k = n\delta_1$ and $\alpha = f\delta_2$

$$n\delta_1 + f\delta_2 = 2\pi(n - f) \sqrt{\frac{I^2}{I_r^2 - I^2}}$$

If now n is nearly equal to f , so we may put without much error $\frac{f}{n} = 1$ we get,

$$\delta_1 + \delta_2 = 2\pi \left(\frac{n - f}{n} \right) \sqrt{\frac{I^2}{I_r^2 - I^2}} \dots \dots \dots (105)$$

If then we have plotted a curve showing the variation of the current in the oscillatory circuit as its natural frequency is varied we can calculate the sum of the decrements of the circuit and exciting voltage; if one of them is known the other may then be obtained. The curve between (current)² and f will have the shape indicated in Fig. 62; when $f=n$, I has its maximum value I_r , and it decreases as f departs from n . The amount of decrease in I for a given difference between n and f is the same whether f is greater or less than n , provided the value of $\frac{n}{f}$ does not differ materially from unity.

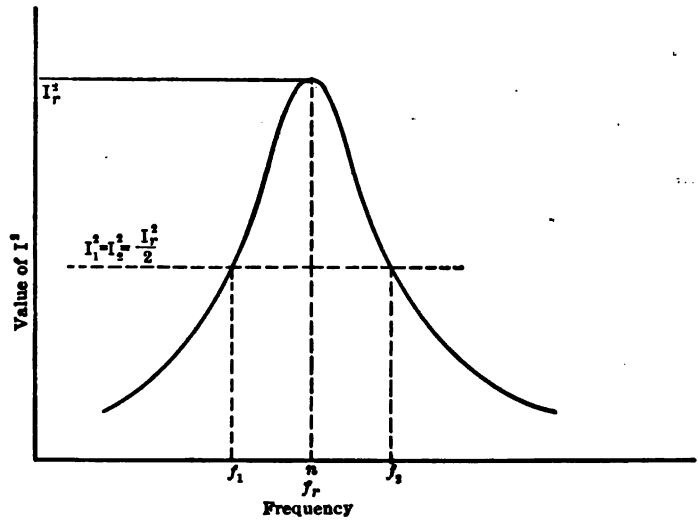

FIG. 62.—Resonance curve of a circuit excited by damped sine wave.

If we then read the two values of f (call them f_2 and f_1 , f_2 being greater than n and f_1 being less than n), so chosen that the current is reduced to $\frac{1}{\sqrt{2}}$ of its resonance value we shall have

$$\delta_1 + \delta_2 = 2\pi \frac{n - f_1}{n} \sqrt{\frac{0.5I_r^2}{I_r^2 - 0.5I_r^2}} = 2\pi \frac{n - f_1}{n},$$

and also

$$\delta_1 + \delta_2 = 2\pi \frac{f_2 - n}{n}.$$

Adding these two values, we get

$$\delta_1 + \delta_2 = \pi \frac{f_2 - f_1}{n} = \pi \frac{f_2 - f_1}{f_r} \dots \dots \dots (106)$$

In this equation f_r is that frequency of the circuit which gives greatest current; this frequency we know to be practically the same as the frequency of the impressed force which we have been calling n .

As the frequency of a circuit varies with the square root of the capacity in the circuit, we may write Eq. (106) in terms of the amount of capacity used in getting the resonance curve. If C_r is the value used to get the maximum current and C_2 and C_1 correspond to f_2 and f_1 of Eq. (106) then we have, very nearly,

$$\delta_1 + \delta_2 = \frac{\pi}{2} \frac{C_2 - C_1}{C_r} \dots \dots \dots (107)$$

This is the equation generally used when using a wave meter for getting the decrement of a transmitting set; although approximations have been made in deducing it, the errors incurred are small if the sum of the two decrements is small (say less than 0.25), which is always the case in practical radio sets.

CHAPTER V

SPARK TELEGRAPHY

Spark Transmission and Equipment.—The transmission of intelligence by means of electromagnetic and electrostatic energy radiation from an open oscillator, produced by the high-frequency oscillatory discharge of a condenser in an associated circuit, is called spark telegraphy. The fundamental circuits of such a transmitter have already been discussed (Chapter III), and the action and inherent necessity of the spark to this form of transmission indicated. Thus the reason for the term “spark” telegraphy.

In the diagram of connections (Fig. 1) and description of the transmitter, a certain conventional and more or less standard arrangement

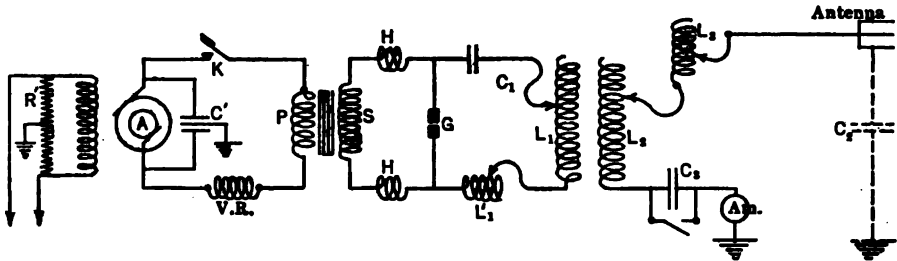

FIG. 1.—Circuit diagram of the ordinary spark transmitter.

of equipment has been assumed. Commercial transmitters may differ from this arrangement in several details, for instance, in the method of energy supply, form of spark gap used, and the kind of coupling employed between the closed and open (radiating) oscillatory circuits.

An examination of the set shows it to consist of three main circuits: (1) a low-voltage, low-frequency circuit which includes the alternator (A), the key (K), the low-tension winding of the step-up power transformer (P), and a variable reactance (V.R.), which is also called a reactance regulator or choke coil; (2) a high voltage, high- and low-frequency circuit, including the high-tension winding of the step-up power transformer (S), the capacity (C_1); the inductances (L_1) and (L'_1) and the radio-frequency choke coils (H), the spark gap G being shunted across the circuit as shown in the diagram; that part of this circuit comprising

L_1 , L'_1 , C_1 , and the gap, in series is called the *closed oscillating circuit*; (3) a third circuit, known as the *open (radiating) oscillatory circuit*, of high frequency only, containing the following equipment: Inductance L_2 , coupled inductively with L_1 , and forming with L_1 the *oscillation transformer*; a tuning inductance L_3 , the antenna or aerial (represented in the diagram by a fictitious lumped capacity C_2) the hot-wire ammeter A_1 , and the short wave condenser C_3 equipped with short-circuiting switch.

The detailed action and function of the above equipment, representing all the essential elements of a spark transmitter, will now be discussed.

The Alternator.—The function of the alternator is to supply electrical energy to the set, it itself usually being driven by a direct-current motor.

Where a supply of electrical energy is not available it may be driven by a gas, steam, or oil engine. When motor driven, a storage battery is sometimes connected across the supply mains, to steady the voltage impressed on the motor and to act as a reserve in case of interruption to the source of supply.

The construction and characteristics of the alternator are discussed below (page 287):

The Switch K, called the key, is used to control manually the energy supply to the step-up transformer. If this energy is interrupted in accordance with a prearranged or conventional plan (i.e., the International Morse Code), then the radiated energy will vary in the same manner, and thus signals may be transmitted. (See Chapter III.) The diagram indicates the key as making and breaking the main circuit current. On the higher powered sets it becomes impracticable manually to open the main circuit directly, due to the large currents involved requiring a long break and heavy set of contacts. The key, therefore, is usually arranged to operate in an auxiliary circuit, connected to actuate one or more relays, whose contacts, in turn, make and break the main circuit.

The Step-up Transformer.—Consisting of high and low-tension windings S and P , raises the potential of the energy supply from perhaps 120 to 10,000–20,000 volts. This increase in the voltage is required for the proper operation of the spark gap.

For the lower powered sets, i.e., sets having less than 1 kw. rating, the alternator and step-up transformer may be replaced by a storage battery and high-tension induction coil. The limitation and operation of the induction coil is considered in detail below (see page 282).

The capacity C_1 forms the reservoir for energy storage as the voltage impressed across the inductance ($L_1 + L'_1$) and C_1 approaches its maximum value. That the impressed voltage is practically all consumed across the condenser, and the condenser thus charged to this voltage, can be seen at once if the reactance of ($L_1 + L'_1$) and C_1 are considered at the frequency

of the supply. Thus, assuming $L_1 + L'_1 = 50\mu h$, $C_1 = .002\ \mu f$, frequency = 500 cycles, we have,

$$X_L = 2\pi fL = 2\pi \times 500 \times 50 \times 10^{-6} = .157\ \text{ohm},$$

$$X_C = \frac{1}{2\pi fC} = \frac{10^6}{2\pi \times 500 \times .002} = 159,000\ \text{ohms}.$$

Since the same current flows through both $(L_1 + L'_1)$ and C_1 on charge, it is apparent that the drop across the inductance is negligible, and that the charging voltage is practically impressed directly across C_1 . Forms of high potential condensers and their construction are described below (page 297).

The inductance L_1 is essential to the closed circuit, since high frequency oscillations are to be produced when the condenser C_1 discharges. In addition to its function of energy storage, L_1 forms the means of coupling the closed and open (radiative) circuits; in conjunction with L_2 it is known as an oscillation or Tesla high-frequency transformer. The variable inductance L'_1 is not essential to the operation of the set, and is seldom used in practice.

The function of the spark gap G has already been briefly considered (Chapter III). Essentially, its action is that of a trigger which permits the stored-up energy of the charged condenser C_1 to be discharged in the form of high-frequency oscillations, when the potential between its electrodes has reached a certain critical value. The several forms of spark gaps used on modern transmitters, and their action, are considered later.

The secondary winding L_2 of the oscillation transformer forms the seat of induced high-frequency electromotive force and is the means of energy transfer from the closed oscillating circuit. To control this energy transfer and to secure proper operating conditions the position of this coil is varied with respect to L_1 , i.e., the coupling between the two circuits is adjusted to give the best results.

When adjusting for the transmission of long wave lengths, it becomes undesirable to tune the open oscillating (radiating) circuit by increasing L_2 , as this may increase the coupling to greater than the desired value; excessive coupling possesses several disadvantages as outlined below.

Function of the Tuning Inductance L_3 .—To tune the circuit, without increasing the coupling the tuning inductance L_3 is inserted; note that coefficient of coupling between the two circuits is decreased if L_3 is increased and L_2 is unchanged. This inductance has no inductive relationship with either L_1 , or L_2 , and is cut into the circuit only when adjusting the set to transmit at the longer wave lengths. The insertion of a capacity in multiple with C_2 , or across L_2 , would produce a similar effect.

Antenna.—The aerial or antenna represents primarily a condenser of large physical dimensions, and forms the radiating element of the set (see Chapter IX). A capacity of small dimensions, such as is used in the closed oscillating circuit, possesses no appreciable ability to throw off or radiate electromagnetic energy even though the frequency of oscillation be extremely high. For this reason the radiating capacity is made of large physical dimensions, and as such is called the aerial or antenna.

Function of the Short-wave Condenser C_3 .—The functions of C_3 is to permit tuning the open circuit with the closed circuit, when the wave length to be transmitted is very short. It is therefore called the short-wave condenser and is connected in series with the antenna, the total capacity of the circuit, and the wave-length, being thus decreased. In the absence of this condenser it would be necessary to tune by decreasing L_2 (L_3 being cut out of circuit at some intermediate wave-length), in which case the energy transferred from the closed to the open circuit may be too small for satisfactory transmission, the coupling having been made too weak.

Protective Equipment.—In addition to the above apparatus, the set is equipped with certain protective devices. High resistances or condensers are connected across the field and armature terminals of the alternator and its driving motor, to prevent the flow of high-frequency currents in these highly inductive circuits. These high-frequency currents may be caused to flow by direct inductive effects from the closed and open oscillating circuits, particularly if the space is restricted, as on shipboard, and the several circuits are close together. High-frequency current flowing or tending to flow through a high inductance means a high-potential drop across the winding, this potential usually being concentrated ("piled up") at the end turns of the winding. This potential may be sufficient to puncture the winding insulation, and to prevent this the coil is shunted by resistance or capacity, through which the high-frequency current can easily flow, without any abnormal potentials being produced. Also this resistance or capacity usually has its neutral point connected to ground, to prevent excessive potential stresses with respect to ground. The connection of a protective resistance (R') and condenser (C') is indicated in the diagram (Fig. 1).

Since the breakdown of the gap virtually short circuits the high tension side of the step-up transformer, some means must be introduced to prevent the abnormal current flow which would otherwise occur under this condition. If this is not done, the transformer and alternator may be damaged, and the arc across the gap become a sustained condition, preventing the recharging of the capacity C_1 , with resultant decrease of the high-frequency energy. Three means may be used, all three involving the insertion of reactance in the low voltage supply circuit: (a) High

reactance (high impedance) in the alternator; (b) an iron-cored inductance in the supply leads to the transformer; (c) high leakage reactance in the step-up transformer.

The action of this added reactance is to rapidly decrease the voltage as the current flow increases, as the gap breaks down. In addition to the above, a more or less resonant adjustment of the circuit constants may be used to secure an equivalent result. The action of this arrangement is discussed in detail on pages 310 et seq.

To prevent any appreciable high-frequency current from flowing through the high-tension winding of the transformer, thus setting up high potentials with liability of puncture to the winding, high-frequency reactance coils H are inserted between the gap and the transformer. These coils have a very low impedance to the flow of current of alternator frequency, but present a very high impedance to the high-frequency discharge current, which is thus forced to follow the gap circuit. These coils may be simply a helix of copper wire wound on a porcelain or bakelite spool, and are designed to possess a high "turn insulation." They can thus safely withstand potential strains which would cause puncture to the transformer winding if permitted to occur at this point. Another advantage is that the high-frequency current is forced to flow in the low-resistance gap circuit, instead of through the higher-resistance by-path presented by the transformer winding. The damping is thus decreased, and the operating efficiency of the set increased. (The damping is decreased by the decrease of closed circuit I^2R losses.) With modern transmitters, where the end turns of the high-tension winding have been specially insulated to withstand the high potentials, these high-frequency choke coils are usually omitted.

Conductive and Capacitive Coupling.—The above description of the spark transmitter has considered an oscillation transformer, with two windings, conductively independent, but coupled electro-magnetically, as the means of transferring energy from the closed to the open oscillating circuit. This is the form in common use to-day, and is known as inductive coupling. Under certain conditions, where space is at a premium, such as military field sets and aeroplane equipment, it becomes desirable to concentrate the oscillation transformer into one winding, the connections then being made as shown in Fig. 2 (A).

Such coupling, which is known as direct or conductive coupling, is equivalent as a means of energy transfer, to the inductive type. It, however, is not so flexible in its coupling adjustment as the latter, and requires two movable contacts for the open circuit terminals, if very loose coupling is desired (Fig. 2 (B)). In any case the adjustment is more difficult than with the two-coil transformer, wherein the coupling is easily adjusted by movement of the one coil (open circuit) relative to the other (closed

circuit coil). Direct coupling has the advantages of reduced space requirements, simplicity and increased efficiency; it avoids also the necessity of insulating the two windings from each other. This latter point is important only when very tight coupling is desired, as under normal coupling conditions the space between the two coils is such that the insulation is ample, unless very high voltages are involved.

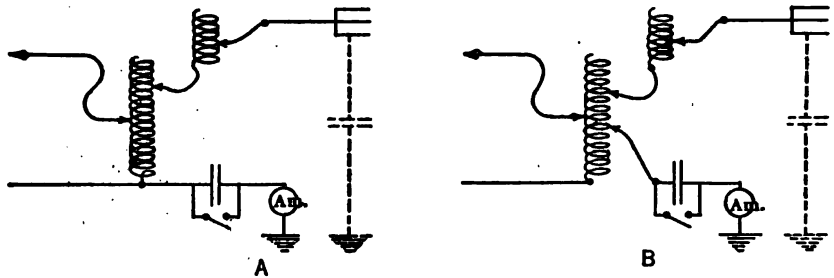

FIG. 2.—Two schemes for using conductive coupling in a spark transmitter.

Capacitive coupling, instead of the inductive form, could also be used, but is very rarely adopted in practice, due to the greater adjustment facility and simplicity of the latter form. Capacitive coupling is shown in Fig. 3.

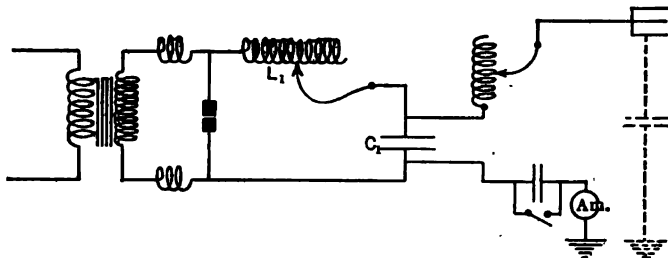

FIG. 3.—A capacitively coupled transmitter.

Forms of Excitation.—All of the above methods involve what is known as indirect excitation, that is, energy is stored in the closed-circuit condenser, and a portion then transferred from this circuit to the open or radiating circuit, when the high-frequency oscillatory discharge occurs. The antenna, however, possesses distributed capacity and inductance and the earlier forms of transmitters stored the energy in this antenna capacity directly, the antennæ circuit being thus synonymous with the closed circuit of the modern transmitter. This method is known as direct excitation, and possesses advantages as regards economy in first cost, less space requirements, and greater simplicity. The connections are shown in Fig. 4.

This arrangement may be used particularly for very small power sets, using a storage battery and induction coil as the source of high potential energy. It will be noted that the capacity of the aerial is charged by the induction coil, and when the gap breaks down, a high-frequency discharge is produced exactly as in the case of the closed circuit. A portion of the high-frequency energy will be radiated, and by its proper control signals may be transmitted as with the indirectly excited transmitters.

The circuit possesses the fundamental disadvantage that the gap resistance is in the radiating circuit. The radiated energy will thus have a high decrement and cause interference to any station which may be within its sending radius, unless the station be tuned to a wave length, remote from that of the transmitter considered. The efficiency of such a radiator is low, most of the energy being dissipated as heat in the spark resistance and as other circuit losses. Also the capacity of the antenna is small compared to the capacity which may be placed in the closed circuit

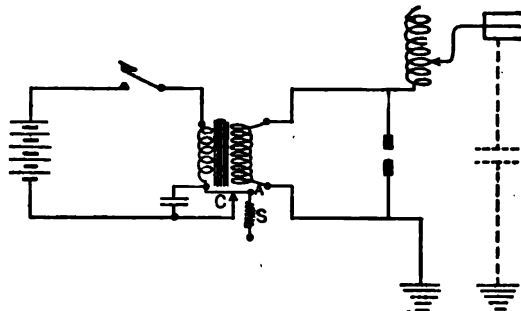

FIG. 4.—The earliest type of radio transmitter, using direct excitation, the spark gap being in the antenna circuit.

when indirect excitation is used thus the current through the spark gap is much smaller than it would be if the gap were in a high capacity circuit. The resistance of the gap is higher the smaller the current through it, hence the high damping effect of the gap when placed in the antenna circuit. The decrement of the radiated energy is still further increased by the increased length of gap required as well as by excessive leakage losses, corona, etc., which may occur at these increased voltages. The decrement may be reduced by inserting a low resistance inductance L in the aerial circuit as shown in Fig. 4, and as shown by the formula for decrement given on page 214. The oscillations will thus decay more slowly, giving a more sustained effect to the radiated energy; but the amount of energy radiated is less.

It may not be possible, however, to insert this inductance, if it is desired to transmit at certain short wave lengths. For these reasons the direct excitation method is not used on medium- or high-powered transmitters, and is found only on very small or emergency sets, when low first cost or space restriction may be the primary consideration.

Means of Energy Supply.—Modern spark transmitters may be equipped with one of two forms of energy supply to the closed circuit:

- (a) The storage battery and induction coil.
- (b) The alternator and step-up power transformer.

The Storage Battery and Induction Coil.—Sets utilizing the storage battery and induction coil are usually of an emergency or portable nature, and of relatively low power. (Not over 1 kw.) The connections of such a set have already been indicated in Fig. 4. The direct excitation used in the figure, however, is rarely employed, conductive coupling between the closed and radiating circuit usually being employed.

The induction coil is simply an "open-core" transformer, possessing a primary winding wound with a few turns of heavy wire, and a secondary winding consisting of a large number of turns of fine wire. Closing the key completes the primary circuit and connects the primary winding directly across the battery. Current will thus flow through the winding, magnetizing the iron core. When the magnetization has reached a certain critical value, the armature *A*, Fig. 4, is drawn toward the core, opening the circuit at the contact *C*. This sudden opening of the primary causes the flux set up in the core, which links both secondary and primary windings, to collapse or decrease at a very high speed. In collapsing the flux cuts the secondary winding and a very high electromotive force is thus induced in this winding. This e.m.f., impresses on the antenna circuit, charges the antenna up to that potential, at which the gap breaks down, whereupon a high frequency oscillatory discharge occurs, as already described in the first pages of Chapter IV.

The decrease of flux in the core reduces the attraction on the armature *A*, which is drawn back to its initial position by the spring *S*, thus closing the primary circuit again, whereupon the cycle of events just described is repeated. The frequency with which the armature makes and breaks the primary circuit determines the frequency of the high voltage pulses impressed on the closed circuit, and thus also determines the group or spark frequency of the set. This frequency may range from 30 to 100 "makes" and "breaks" per second on modern interrupters of this type, known as the "hammer break" type. The constants of the armature system (the inertia of the armature and the spring tension) determine this frequency, which may therefore be adjusted within the limits indicated above to give a required group frequency. This is usually accomplished by adjustment of the spring tension and initial position of the armature.

Requirements of Interrupter Action.—Since the function of the induction coil is to charge a capacity to certain high potential in a very short interval of time (the duration of the high e.m.f. in the secondary is very short), the following requirements must be fulfilled.

- (a) The primary must be broken cleanly and quickly, so that the primary current and thus the flux surrounding both windings, decreases

very rapidly, and (b) the time constant of the secondary or high-tension circuit must be sufficiently low. In considering the above requirements, it is desirable to analyze somewhat carefully the actions which occur in the induction coil at "make" and "break."

Action of Shunting Condenser.—If we assume the operating key closed, we have the condition of a constant e.m.f. impressed on an inductive circuit. Therefore the current in the primary increases, as already described (page 32), and as indicated in curve *a*, Fig. 5. The flux through

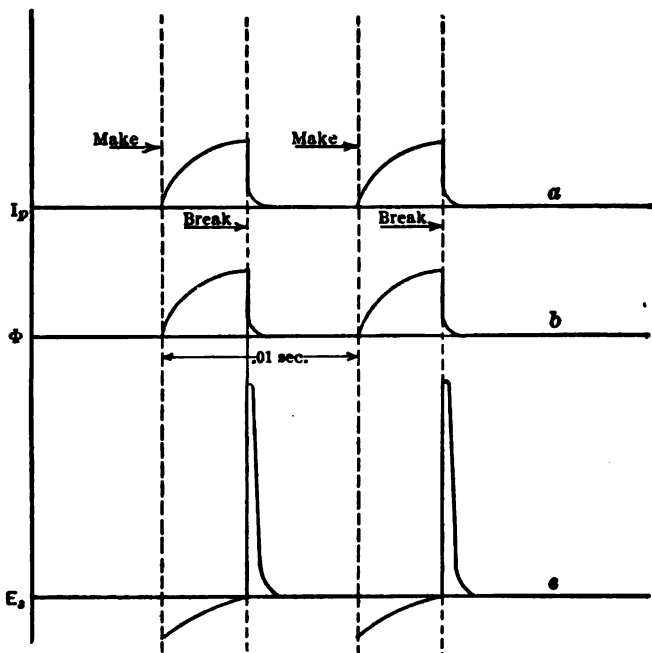

Fig. 5.—Currents and voltages in the circuits of a spark coil having a vibrating contact.

the core and linking both windings follows a nearly similar variation, as shown in curve *b*. We therefore have voltages induced in both windings of the coil; in the case of the primary this voltage represents the e.m.f. of self-induction; in the case of the secondary, it is simply an induced e.m.f. and is equal to $N_s \frac{d\phi}{dt}$, N_s being the number of secondary turns.

The secondary induced e.m.f. is indicated by curve *c*.

At the instant the contact closes the primary circuit the changing flux in the core must be just sufficient to balance the impressed, or battery, voltage. We may therefore write for this instant, $\frac{d\phi}{dt} = \frac{E \times 10^8}{N_p}$, E being the impressed voltage and N_p being the number of turns in the primary

winding. If there were no magnetic leakage between the primary and secondary coils the induced secondary voltage would be equal to $\frac{N_s}{10^8} \frac{d\phi}{dt}$ which may evidently be written $E \frac{N_s}{N_p}$. Hence at the instant of "make" the induced secondary voltage is comparatively low, practically negligible compared to the voltage obtained at the break.

When the primary circuit is interrupted at the contacts of the vibrator, a high e.m.f. will be induced in each winding, the relative value of the primary and secondary e.m.f. being determined by the turn ratio. The counter e.m.f. of self-induction will tend to maintain a current in the primary across the gap between the vibrator contacts, and if permitted to do so, this current will flow as an arc across this gap, injuring the contacts and preventing the very rapid decrease of flux desirable. To prevent this action, a large capacity is shunted across the vibrator contacts as shown in Fig. 4. The counter e.m.f. of the primary now charges this condenser, which, since its capacity is relatively large,¹ does not rise to very high potentials, and thus limits the potential across the contacts, which cannot exceed that of the condenser. Sparking or arcing at the contacts is thus avoided.

As the condenser becomes charged, and the energy of the magnetic field is discharged, a point will be reached where the potential of the condenser is greater than that of the coil. The condenser will then discharge into the coil, but the current will oppose the original flow of current and therefore increase the rate of decay of current in the circuit. In effect the primary circuit is an oscillating circuit, although the first oscillation only is of importance, due to the very high damping. The effect of the shunting condenser is thus (a) to prevent arcing and sparking at the contacts of the vibrator, resulting in a cleaner break, higher induced e.m.f.'s in the secondary winding, and decreased injury to contacts; (b) an opposing discharge current flows into the primary winding, which increases the rate of decay of flux, thus also increasing the e.m.f. induced in the secondary. For these reasons a shunting condenser is always used in connection with the induction coil, being usually assembled in the base of the induction coil case.

Duration of High Potential Induced in Secondary Circuit.—The period of time during which the high voltage is available at the secondary terminals is extremely small. This may be seen from the following: if the primary circuit has no condenser, the decay depends primarily on the quickness and cleanness with which the vibrator opens its contacts. The

¹ The condenser should be only *just large enough* to suppress arcing at the contacts; if the value of the capacity is greater than this required amount the secondary induced voltage will be lower than if a proper condenser is used.

resistance then inserted in the circuit is very high and the time constant ($= \frac{L}{R}$) is therefore very small. The collapse of the flux is then correspondingly rapid if we neglect the effect on this flux of whatever current may be present in the secondary circuit during this time.

If a condenser shunts the contacts, the time is fixed by the natural period of this circuit; thus if we assume $C_p = 1\mu f$, $L_p = .01$ henry, the time of the first alternation of secondary voltage is given by the equation

$$t = \frac{2\pi\sqrt{LC}}{2} = \frac{2\pi \times 10^{-3} \times \sqrt{.01 \times 1}}{2} = \frac{2\pi \times 10^{-3} \times 1}{2} = 3.14 \times 10^{-4} \text{ sec.}^1$$

If a spark does not take place, other alternations of voltage will follow this one, but will be successively smaller in amplitude and hence would evidently not produce a spark if the first alternation did not.

Action in the Secondary Circuit.—In the secondary circuit, the e.m.f. induced must overcome the reactions of the winding resistance and the condenser, or

$$N_s \frac{d\phi}{dt} = I_s R_s + v_c \dots \dots \dots (1)$$

This circuit is equivalent to the circuit considered on page 37, where the charging of condenser through resistance was discussed. The induced voltage may be considered as acting on the capacity through R_s . The time constant of this circuit is $C_s R_s$ and since $N_s \frac{d\phi}{dt}$ has such a short duration, it is essential that $C_s R_s$ be small, if the capacity is to be charged to the maximum possible potential. Since C_s is fixed by the wave length and energy requirement of the set, R_s must be made as low as possible. For this reason induction coils intended for radio service have their secondaries wound with wire several sizes larger than would ordinarily be used, as for instance, in a coil intended for gas-engine ignition. It must be borne in mind that the actual electrical efficiency of the coil intended for radio work may be of importance, and when this is so, it is evident that the $I^2 R$ loss in the secondary winding must be kept as low as possible. This is another reason for keeping the resistance of the secondary winding low.

The action which occurs in the secondary circuit at the instant of

¹ This elementary analysis is based on the assumption that the secondary circuit has no effect on the time constant of the primary circuit; if a condenser is connected across the secondary terminals (or the internal capacity of the secondary winding has an appreciable effect) this assumption is hardly warranted.

primary "break" is indicated to a larger time scale in Fig. 6¹ where (a) indicates the conditions with the spark gap disconnected from the secondary circuit while (b) shows the operation when both the condenser and gap are across the high-tension winding as in normal operation.

The duration of the train of high-frequency oscillations, assuming a decrement of 0.2 (which is not excessive for this type of circuit), and a frequency of 1,000,000, is calculated as follows:

$$N = \frac{4.6 + \delta}{\delta} = \frac{4.6 + 0.2}{0.2} = 24 \text{ waves,}$$

and the duration is,

$$T = 24 \times \frac{1}{1,000,000} \\ = 24 \times 10^{-6} \text{ seconds.}$$

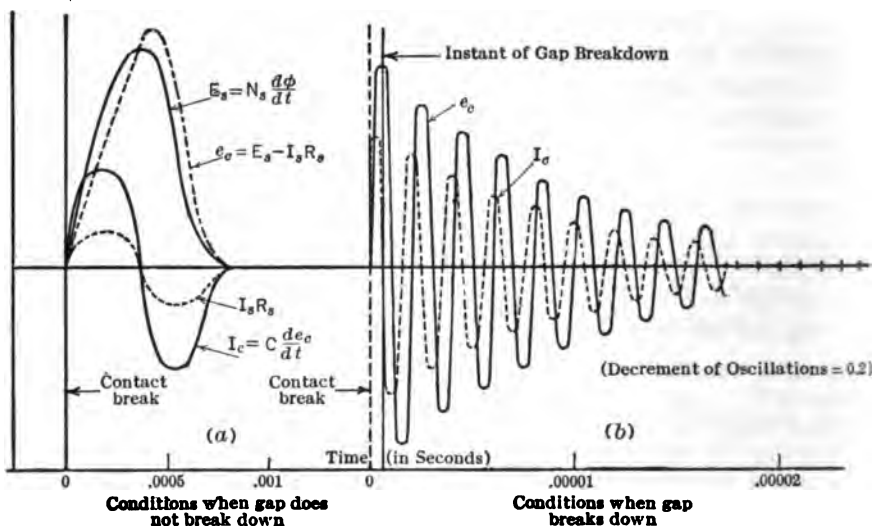

FIG. 6.—Action of a spark coil connected to an oscillatory circuit.

This time would be indicated by practically a straight vertical line on the scale of Fig. 5. Conditions as indicated in Fig. 6 (a) would also apply to the primary circuit if a suitable condenser is used across the contacts.

Types of Interrupters.—As has been mentioned, the induction coil is used chiefly on sets of low power, usually representing emergency equipment. On these the principal type of interrupter used is the "hammer

¹In calculating the time scale for diagram 6 (a), it has been assumed that the secondary winding has an inductance of 25 henries, and that the condenser used in the secondary circuit has a capacity of .002 microfarad.

break" interrupter as mentioned previously. This type of break, however, is limited in its ability to interrupt large currents, and in the frequency of interruption to which it can be adjusted. The turbine break, which opens the primary circuit by periodically interrupting a jet of mercury which completes the circuit, may be used when larger currents and power are involved. The frequency of interruption is also under ready control, and can be varied from 30 to 1200 breaks per second, by adjusting the speed of the rotating member, which is usually driven by a small motor.

The electrolytic type, and various types of motor (commutator) interrupters have also been used. The student is referred to Fleming's "Principles of Electric Wave Telegraphy and Telephony" for more detailed information on these types, which are relatively little used on modern spark transmitters.

The foregoing interrupters are not capable of properly "making" and "breaking" large currents many times per second (500 or 1000) and for this reason the induction coil is at present limited in application to small power sets.

Alternator and Step-up Transformer.—The use of an alternator and step-up transformer is practically universal, with the exception of very small sets, which may economically and conveniently be supplied by a storage battery and induction coil as described above. Alternators for radio service are usually motor driven, where electrical power is available. If no electrical source of power is provided, a gas, oil engine, or small steam turbine may be used as the prime mover.

Alternator Construction.—The general construction of such an alternator does not differ radically from that of the ordinary machine of power engineering, and will be in accordance with one of the following constructional arrangements:

- (a) Fixed Field and Rotating Armature;
- (b) Rotating Field and Fixed Armature;
- (c) Inductor Type.

The first two arrangements have been widely used in the past, while the third type is more recent. It possesses the advantage that all windings are fixed in position and thus liability of damage to insulation is reduced and greater mechanical strength and ruggedness is obtained.

Alternator Action.—The action of all three arrangements is to induce in the armature winding an alternating e.m.f. Types *a* and *b* secure this result by varying the position of the field windings relative to the armature winding, thus causing a periodic change in the flux linking a given coil and inducing therein an alternating e.m.f. This action is indicated in Fig. 7.

In the inductor type the relative position of the armature and field

windings is fixed, but a revolving rotor periodically varies the reluctance of the flux path, and thus the flux linking a given winding in the armature, periodically increases and decreases as indicated in Fig. 8. The rotor carries no windings, the projections (pole teeth) on its periphery acting to cause the required periodic variation of flux.

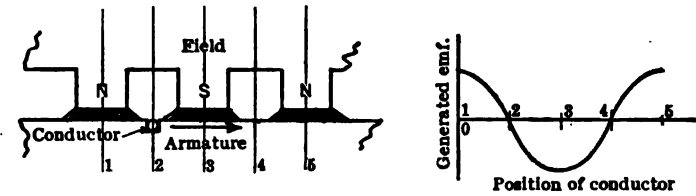

FIG. 7.—Induction of e.m.f. in the conductor of a revolving armature alternator.

Frequency of Generated E.M.F.—In the case of the first two types the flux of adjacent poles is always in the opposite directions: Thus a conductor passing through the flux emanating from the N pole will have induced in it an e.m.f. of one direction or polarity, and in passing through the S pole flux, will have the direction of e.m.f. reversed, i.e., a complete cycle of alternating e.m.f. is induced in the conductor as it passes a pair of poles.

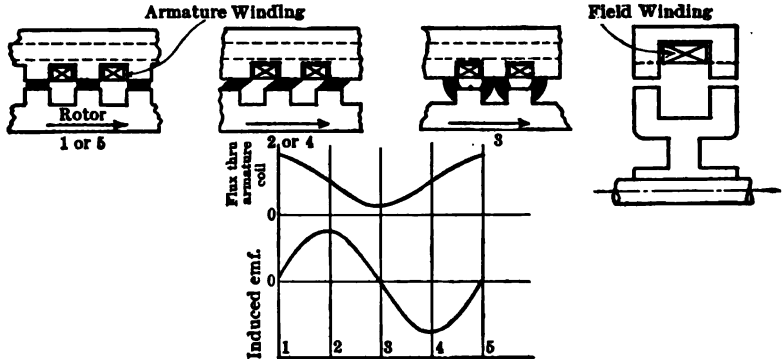

FIG. 8.—Action of an inductor alternator.

In the case of the inductor type, the direction of the flux relative to the armature winding is always the same, but this flux varies periodically with time as the reluctance of its path increases and decreases. When the flux is increasing the induced e.m.f. ($e = N \frac{d\phi}{dt}$) will have a certain polarity. When the rate of change of flux reverses, that is, becomes a decrease, the induced e.m.f. reverses and an alternating e.m.f. is thus developed.

For classes (a) and (b) the frequency, i.e., the number of complete cycles per second, is equal to the number of pairs of poles (in passing one pair of poles the induced e.m.f. passes from 0 to + maximum to 0 to -maximum and back to 0) times the revolutions per second, or

$$f = p \times \text{r.p.s.} \dots \dots \dots (2)$$

Thus a 4-pole machine, when driven at 1800 r.p.m., will give a frequency of 60 cycles per second.

In the inductor type, a complete cycle is obtained when the rotor moves through the angle of the pole pitch (pole pitch = distance from a point on one field projection on rotor to the corresponding point on the adjacent projection).

Thus, if the rotor makes one complete revolution, the cycles generated are equal to the number of teeth or projections on the rotor. The cycles per second are thus equal to

$$f = n \times (\text{r.p.s.}), \dots \dots \dots (2a)$$

where n = the number of pole teeth, or slots on the rotor

Radio alternators differ from alternators used for power engineering, in two important characteristics: (a) frequency, (b) internal reactance. The frequency of the alternator determines the spark or group frequency of the set (neglecting the application of the non-synchronous gap discussed below), which in turn determines the number of times the receiver diaphragm is impulsed per second at the receiver station, or the pitch of the note, heard in the phones by the receiving operator. Modern receiver diaphragms normally have a natural frequency of about 1000 cycles per second, and the human ear is most sensitive at about this frequency; it is therefore desirable to use this frequency of wave trains, if the maximum audibility of the received signal is to be obtained. (When the signal frequency corresponds to the natural frequency of the telephone diaphragm maximum signal strength for a given impressed e.m.f. results.) Thus modern radio alternators are constructed to give very much higher frequencies than are used in power engineering practice, a usual value being 500 cycles, giving a group frequency of 1000, when the gap is adjusted to break down once every half cycle.

This high frequency requires a large number of poles, or excessively high speeds, for its generation. Thus a four-pole machine would have to be run at 250 r.p.s. or 15,000 r.p.m., to give 500 cycles per second. This high speed would involve difficult and expensive construction and therefore the number of field poles is increased to obtain the desired frequency at a lower speed. To secure the required number of poles around the periphery of the armature, without making the latter excessively large,

requires special construction. Thus, assuming an alternator driven at 1500 r.p.m., or 25 r.p.s., we have,

$$f = 500 = n \times 25, \text{ where } n = \text{No. of pairs of poles} \\ n = 20$$

Thus, 20 pairs, or 40 poles, would be required for the field. To minimize the space required, field coils are placed only on alternate poles (N), the remaining poles (S) thus being consequent poles. This construction is illustrated in Fig. 9.

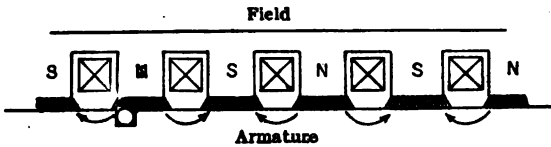

FIG. 9.—The ordinary small radio alternator has a field coil on every other pole only, half the poles being consequent poles.

With the inductor type, very much higher speeds are permissible, as all windings are

fixed in position, and the rotor can be specially designed and constructed for high-speed operation. Such construction is illustrated by the Alexanderson high-frequency alternator described in Chapter VII. With the inductor type it is not difficult to secure the necessary frequency by increasing the number of pole teeth, keeping the speed within reasonable values. Thus for the case considered above, 20 teeth, each tooth and its associated slot being equivalent to a pair of poles, would be formed on the rim of the rotor.

Driving Motor.—The driving motor for any type of radio alternator should have a practically constant speed-load characteristic over the load range in which it is to operate. This requirement is fulfilled sufficiently well by the modern shunt motor, although differential compound wound motors are also used to secure the desired constancy in speed. Poly-phase synchronous or induction motors may also be used where a.c. power only is available.

Internal Impedance of Radio Alternators.—The second characteristic which differentiates the alternator used for commercial power purposes and the radio alternator, is the internal or armature impedance. The radio alternator operates always for a small part of its cycle, under short-circuit conditions. It has already been indicated (page 278) that the excessive current which would flow in the alternator and transformer windings throughout the interval during which the gap is carrying current and hence has very low resistance, may be minimized by high reactance in the transformer, artificial inductance in the transformer supply leads (choke coils), or high impedance in the armature of the alternator. The last named method is that usually employed, and modern practice indicates that the high impedance alternator is the best solution of the problem.

Choke coils or reactance regulators represent additional equipment and complication, and are therefore relatively little used.

A high armature impedance means essentially a high armature reactance, the resistance usually being quite small compared to the reactance. The reactance of the armature is made up of two components:

- (a) leakage reactance;
- (b) armature reaction.

The leakage reactance is caused by the flux surrounding the winding conductors, this so-called leakage flux having no effect on the main field flux. It is essentially a local flux, as indicated in Fig. 10.

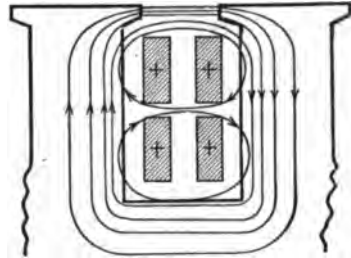

FIG. 10.—Conventional diagram of leakage flux around an armature conductor.

This flux induces a c.e.m.f. of self-induction in the armature winding, and represents the inherent reactance of the armature circuit. The voltage required to send a current I through the armature at standstill is therefore,

$$E = IZ, \text{ where } Z = \sqrt{R_A^2 + X_{\text{leakage}}^2},$$

the measurements being made as for any inductive circuit. They must be repeated with the armature slots in several different positions with respect to the field poles, and the results averaged, since the reluctance of the leakage flux path is affected by the position of the field poles.

Armature reaction is the name given to the distorting and demagnetizing effect of the armature magnetomotive force on the main field. (It is evident that since the armature is made up of turns of wire carrying current wound on an iron core, that the armature represents a certain number of ampere turns, and thus also a m.m.f.) This effect is separate from the leakage flux (which does not necessarily react on the main field), and is indicated in Fig. 11.¹

The first reactance causes a real reactive voltage which must be overcome by the generated e.m.f. in the circuit. The second reaction may be considered as an apparent reactance inserted into the circuit, the induced e.m.f. being assumed constant. Actually the induced e.m.f. does not remain constant, but increases on leading load and decreases on lagging load. The relation between terminal voltage, armature current, armature

¹ In Fig. 11 the vectors showing armature m.m.f. are merely indications of the average effect of the armature m.m.f.; actually the armature reaction of a single-phase alternator (all radio alternators are single phase) is variable in magnitude and direction. For an elementary analysis see Morecroft, "Continuous and Alternating Current Machinery," p. 244 et seq.

constants, and armature reaction is indicated in Figs. 12 and 13, which have been drawn for a commercial alternator and a machine intended for radio service under normal load and sustained short-circuit conditions.¹ On the former machine the short-circuit current (sustained value) may be 2.5 to 3 times the normal value, while with the radio alternator, the short-circuit current is only slightly larger than the normal value. Thus the current carried in the low-tension circuit does not increase to excessive value when the gap break-down short-circuits the transformer, and thus abnormal strains and resultant damage of equipment are prevented. In other words

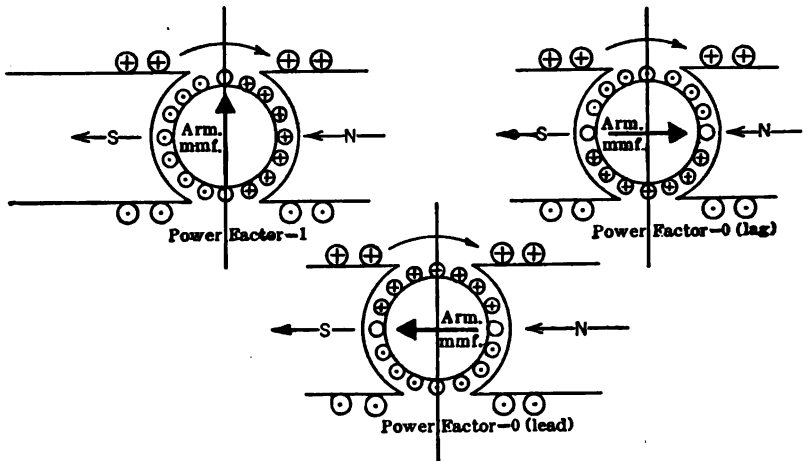

FIG. 11.—Various directions of the armature magnetomotive force, for loads of different characteristics.

on modern alternators designed for radio service it does not require an excessive current in the armature to make the armature ampere turns practically equal to those of the main field. This means that the effective or net ampere turns are small, and the net flux is small; thus only a small e.m.f. is induced in the alternator winding, and the short-circuit current is correspondingly small.

The Power Transformer.—The function of the power transformer in a transmitting set has already been outlined on page 276. The choice and design of such a transformer are of great importance, in so far as the set may work very poorly or fail altogether unless the transformer has the proper characteristics.

¹ It must be noted that the short-circuit condition, i.e., broken down spark gap, on the radio alternator exists for such a small fraction of the cycle, that conclusions reached from the short-circuit diagram in Fig. 13 are not directly applicable. An exact treatment would require the analysis of successive short-circuit transients.

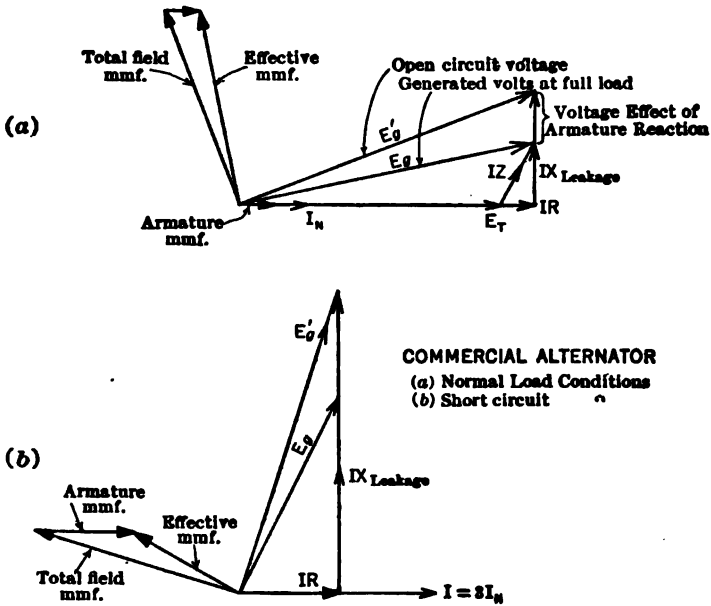

FIG. 12.—Regulation diagram for ordinary alternator.

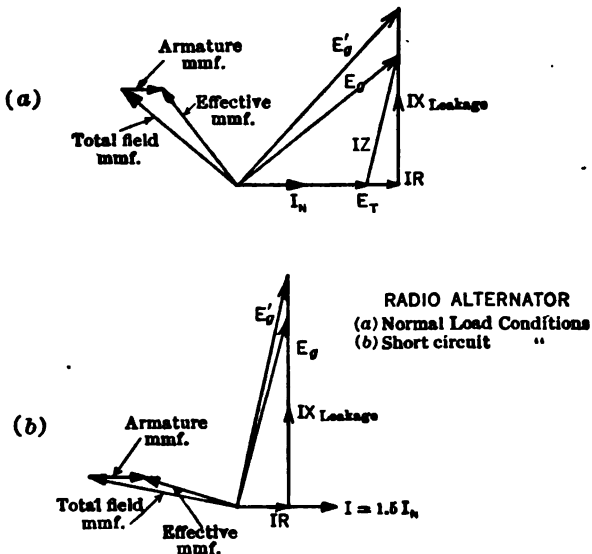

FIG. 13.—Regulation diagram for radio alternator showing greater effect of armature leakage and magnetomotive force.

In order that the following discussion be more fully understood Fig. 1 of page 275 is here reprinted, as Fig. 14.

The main requisites of a power transformer are:

1st. That it shall charge the condenser C_1 to the voltage necessary to store therein an amount of energy such that, when the gap G breaks down and the condenser discharges through the gap and the primary L_1 of the oscillation transformer, the antenna will receive the required amount of energy.

2d. That when the gap G breaks down, and thereby practically short-circuits the high-tension side of the transformer, the current flowing therein, and also through the gap, will be as small as possible. The first of these requisites will be illustrated by means of a numerical example.

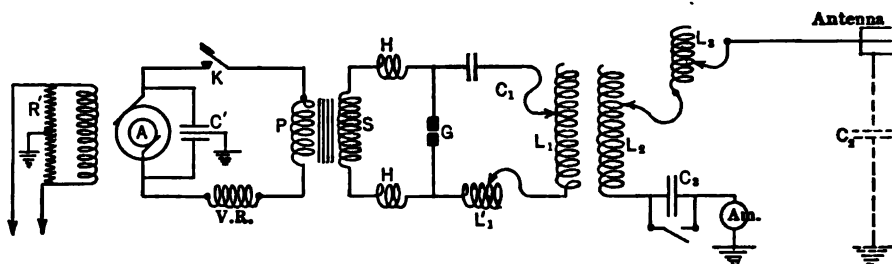

FIG. 14.—Spark transmitter circuit.

Assume the following:

Antenna to be supplied with 200 watts.

Efficiency of transformation from C_1 to antenna = 30 per cent.¹

Capacity of $C_1 = 0.012$ micro-farads.

Frequency of alternator = 500 cycles per second.

Number of sparks per second = $2 \times 500 = 1000$.

Then:

Power to be supplied to condenser $C_1 = \frac{200}{0.3} = 670$ watts. The voltage to which the condenser must be charged is obtained from the formula:

$$\frac{CV^2}{2}N = W, \dots \dots \dots (3)$$

where

C = capacity of condenser in farads;

V = voltage to which condenser is charged;

N = number of sparks per second;

W = power in watts.

¹ This figure is, of course, low; it has been reported that a spark set may have an efficiency as high as 60 per cent, measured by ratio of antenna high-frequency power to motor input; an average figure is probably 40 per cent.

Whence:

$$V = \sqrt{\frac{2W}{CN}} = \sqrt{\frac{2 \times 670}{0.012 \times 10^{-6} \times 1000}} = 10,500 \text{ volts.}$$

The above simply means that the transformer must be able to charge the condenser to 10,500 volts once for every half cycle, and that at this voltage the gap shall break down.

The transformer must be very well insulated, for the first few turns at any rate, not only because it itself must develop a high voltage, as shown above, but also because, after the gap has quenched,¹ radio-frequency e.m.f.'s are induced by the antenna circuit into the primary of the oscillation transformer and are therefore impressed upon the secondary winding of the power transformer. These high-frequency e.m.f.'s produce high-frequency currents, which flow, by condenser action, from turn to turn and layer to layer through the high-tension side of the power transformer and even through the low-tension side; unless the insulation has low dielectric loss and unless it is especially heavy near the end turns of the high-tension side, where the dielectric currents are largest, it is likely eventually to break down.

The second requisite of the power transformer is of importance because if, when the gap breaks down, the current through the power transformer and the gap should be large, not only would there be a large unnecessary waste of power but, in addition, the large current would maintain an "arc" through the gap and thus keep this "closed," a condition which, as is pointed out on page 310, should be decidedly avoided. In order to meet the above the circuit consisting of the alternator, the reactance $V.R.$ (see Fig. 14), the power transformer, the inductances $H-H$, the condenser C_1 , and the inductances L_1 and L'_1 are arranged so that, when the gap is open, the impedance of this circuit at the alternator frequency will be low, and, when the gap breaks down, the impedance of the circuit of the alternator $V.R.$, the power transformer $H-H$, and the closed gap will be very much higher. Thus, when the gap is open the flow of current will not be impeded, while when the gap breaks down the current from the alternator will be very much reduced. A simple way of obtaining this result is by adjusting the circuit of A , $V.R.$, $P-S$, $H-H$, C_1 , L_1 , L'_1 to have a natural frequency equal² to that of the alternator; so that, when the condenser C_1 and the inductances L_1 and L'_1 are, by the breaking down of the gap, separated from the power transformer, the current in this will be only a small fraction of that flowing when the gap is open. In other words, the entire circuit from the alternator to and including L_1 must resonate

¹ See p. 314 for discussion of quenching.

² In practice, this circuit is adjusted to a natural frequency somewhat lower than that of the alternator, as is pointed out on p. 303.

at the alternator frequency. This requires that the capacity C_1 and the various inductances, including the inductance of the alternator and of the transformer, be properly chosen.

The values of C_1 , L_1 , and L'_1 have to be adjusted to give the correct wave length, and this makes them comparatively small; hence in order that the entire circuit, from the alternator to L_1 , may resonate at the alternator frequency the inductances to the left of the gap (see Fig. 14) must be high.

To illustrate, assume:

$$C_1 = 0.012 = \text{microfarad};$$

$$\lambda = \text{wave length} = 600 \text{ meters};$$

$$f = \text{alternator frequency} = 500 \text{ cycles per second};$$

$$L = \text{total inductance from the alternator to and including } L_1, \\ \text{expressed in terms of high-tension side of transformer, in} \\ \text{henries};$$

$$L_1 + L'_1 = \text{inductance of } L_1 \text{ and } L'_1 \text{ in microhenries.}$$

From formula (15) page 212,

$$f = \frac{1}{2\pi} \frac{1}{\sqrt{LC}}$$

Therefore, for resonance at 500 cycles per second,

$$L = \frac{1}{4\pi^2 \times 500^2 \times 0.012 \times 10^{-6}} = 8.5 \text{ henries.}$$

Again, from formula (18), page 213,

$$\lambda = 1885 \sqrt{0.012(L_1 + L'_1)}$$

or

$$L_1 + L'_1 = \frac{600^2}{1885^2 \times 0.012} = 8.5 \text{ microhenries.}$$

Thus, while the inductance of L_1 and L'_1 must be 8.5 microhenries, the inductance of the entire circuit may be 8.5 henries or one million times as large; hence, practically all of the inductance necessary to bring about resonance at the alternator frequency must be in the alternator, *V.R.*, the power transformer and the choke coils *H-H*.

Up to a few years ago it was common practice to design the transformer with the highest possible inductance or, in other words, with a very large amount of magnetic leakage, so that the most of the required inductance was in the transformer and comparatively little in the alternator and the choke coils; such a transformer was called a "resonance transformer," in so far as its inductance alone was nearly capable of bringing about resonance at the alternator frequency. A transformer of this type was generally made with an open magnetic circuit, a so-called "open-core transformer." The tendency of late is to design the transformer with little leakage (closed magnetic circuit) and hence little inductance,

and place the required inductance outside of the transformer in series with its low-tension side, as at *V.R.* (Fig. 14) or in the alternator armature. Some of the power transformers for the smaller sets are constructed so that the leakage, and therefore the inductance of the transformer, may be regulated; thus, in Fig. 15 by moving the magnetic shunt *M*, which is pivoted at *D*, the air gap *A* may be varied, and in this manner more or less flux may be caused to leak away from the secondary coil *S* and into the shunt *M*. This arrangement is satisfactory for small power transformers, but not so for large transformers, especially in view of the noise due to the vibrations of the shunt *M*, which is difficult to overcome.

It is standard practice at present for any but the smallest-size sets to construct the alternator with high inductance, the transformer with a closed core and hence with low inductance, and to make up the needed additional inductance in the form of a coil *V.R.*, inserted in the primary of the transformer.

It has already been pointed out that the insulation of the power transformer must be of the best,¹ not only because of the low-frequency high voltage but also because of the trouble experienced due to high-frequency currents finding their way into the transformer. If the choke coils *H-H* are used (see Fig. 14) they should reduce to a minimum the high-frequency currents flowing in the transformer; if the choke coils are not used, and this is very common in order to simplify the equipment, then the insulation of the transformer secondary must be augmented in order to take care of the voltages due to the high-frequency currents.

Condensers.—The Audio Frequency Circuit of the Transmitting Set.—The condensers used in a transmitting set are known as “power condensers,” to distinguish them from those used in a receiving set, which are known as “receiving condensers.” A power condenser must, as its very name implies, be capable of handling large amounts of power without serious deterioration or breaking down.

The requisites of a power condenser are:

1st. That the insulation between plates shall be such as to prevent its being punctured by the high voltage used.

¹ In American practice the transformer is generally an open-core transformer, air cooled; in European practice an oil-cooled transformer is generally used, this type being undoubtedly superior to the air-cooled type.

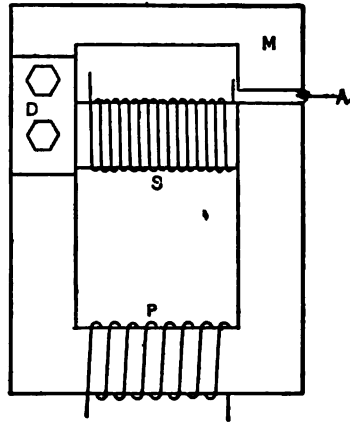

FIG. 15.—Small radio transformers are frequently fitted with an adjustable magnetic shunt.

2d. That the losses shall be small (see page 166, Chapter II). The dielectrics generally used in power condensers are: air, glass, oil and mica. Of these air has the minimum specific inductive capacity, and it causes practically no losses, while the other dielectrics have a much higher specific inductive capacity but suffer more or less energy loss. As regards breakdown voltage air is at a disadvantage as compared with the other dielectrics, but at pressures higher than atmospheric the breakdown voltage for air is very high and it increases in nearly direct proportion to the absolute pressure. A comparison of the characteristics of these dielectrics is given in Chapter II, page 169.

It will be seen from the characteristics of the various dielectrics that if a condenser of a certain capacity is to be designed, the air condenser would have the largest dimensions and the mica condenser the smallest. However, the losses in the air condenser would be very small, while those in a poorly constructed mica condenser might be so high as to make its use prohibitive. Glass condensers in the form of Leyden jars have met with much favor in the radio field and they are being extensively used. Each jar has a capacity of about $0.002 \mu f$, and is capable of withstanding a voltage of about 15,000; for any particular desired voltage and capacity the jars are grouped in series multiple, so that the combination will have the required capacity and breakdown voltage. Condensers with glass as the dielectric are also made with flat pieces of glass covered with tin foil, the space requirements of such condensers being much smaller than for the Leyden jars. They do not stand continued use, however, as well as the Leyden jars, because of the greater amount of heating due to smaller cooling surface.

Oil condensers are not very much used in general practice, but their use is very commendable in places where there is no possibility of spilling the oil. It must be borne in mind, that although the dielectric properties of oil are unfavorably affected by a flash through it, so that oil condensers cannot be expected to give as good service after the oil has once been flashed, they are still serviceable after a breakdown, whereas a solid dielectric condenser, such as mica or glass, is completely spoiled.

The mica condenser is a very desirable one, and is apparently going to largely supplant the Leyden jar for ship sets and similar installations. It is compact, and, if properly constructed, has a loss so small as to be hardly measurable. The impregnation of the condenser with suitable wax must be done sufficiently well to drive out all air completely, as the trapped air bubbles, suffering corona loss, are the source of local heating and thus weaken the dielectric strength of the mica. It must be noted that these condensers are made to be used at the rated voltage and frequency for *intermittent service only* and that even a good mica condenser if used

continuously at the rated voltage and frequency will have its wax melted after an hour or so.

Compressed-air condensers are very suitable where very high voltages and low losses are required; the structure of the condenser, i.e., the metal plates and their insulating supports, is placed in a steel container capable of safely withstanding a pressure up to a dozen atmospheres or more and dry compressed air is pumped in until the required pressure is obtained. It may be easily seen that an air compressor and gauge are necessary auxiliaries of such condensers, and that their use cannot be considered, except for very large land installations, or for laboratories.

On the whole the Leyden jar with its simplicity of construction and large heat-radiating surface affording cool operation is a favorite type of transmitting condenser and would be even more widely used were it not for its large space requirements and liability of breakage.

Transmitting condensers are very seldom constructed so that their capacity may be continuously varied in view of the insulation difficulties resulting from the high voltages dealt with.

The value of the capacity of the condenser used in the closed circuit of a spark transmitter is fixed by the voltage, the spark frequency, and the power set. This point has already been discussed on page 295, from the point of view of the high-tension transformer, and it will be more fully emphasized here from the point of view of the condenser. Rewriting formula (3):

$$\frac{CV^2}{2}N = W, \dots \dots \dots (3)$$

where

- C = capacity of condenser in farads;
- V = voltage to which condenser is charged;
- N = number of sparks per second;
- W = electrical power, in watts, given to condenser.

We immediately note that the power varies directly with N , C and V^2 . The value of N is more or less fixed, because it represents the "tone" of the set and the best tone is supposed to be that due to $N = 1000$ per second. Therefore, if a certain amount of power must be imparted to the condenser a suitable choice must be made of C and V . With a very high voltage the dielectric and leakage losses are likely to be high, and the difficulties of insulating the various parts of the set are such as to make it impractical, and a limit in this direction is soon reached after which, if more power is required, the condenser capacity must be increased. Voltages of 100,000 might be used in large land installations, but in small land and in ship installations the range is 10,000 to 20,000 volts.

It may be easily seen that in large power installations the condenser

must have a very large capacity, even though a high voltage is used. For instance, assume:

- $W = 50,000$ watts;
- $V = 100,000$;
- $N = 1000$ per second.

Then
$$C = \frac{2 \times 50,000}{1000 \times 100,000^2} = 0.01 \mu f.$$

Since this capacity affects the wave length it is plain that even though a small inductance be used in the closed circuit, the wave length will be large; and this is one reason why the wave length of high-power installations is large; there are other reasons which are taken up on page 196. In the example given, even if the inductance in the closed circuit were $200 \mu h$ (which is comparatively small) the wave length would be:

$$1885 \sqrt{200 \times 0.01} = 2660 \text{ meters.}$$

Again, from the formula:

$$\frac{CV^2}{2} N = W$$

we obtain the other:

$$\frac{I^2 R}{\eta} = W = N \frac{CV^2}{2}, \dots \dots \dots (4)$$

where

- I = the current in the antenna;
- R = effective resistance of antenna;
- η = efficiency of transformation from condenser to antenna.

Hence,

$$I = \frac{V}{2} \sqrt{\frac{\eta NC}{R}}, \dots \dots \dots (5)$$

or the antenna current varies with the square root of the capacity.

To show this a test was made on a transmitter with the apparatus connected as shown in curve sheet Fig. 16, where the ammeter measures the high-frequency current in the closed circuit. Of course the current in the antenna, which is here not shown, would be directly proportional to the current in the closed circuit. In this test the gap length was kept constant, the value of the capacity was varied and the voltage of the alternator was regulated until, for every case, a spark occurred for each alternation (as could be approximately determined by the pitch of the spark note); this meant that the voltage to which the condenser was being charged was the same, and, furthermore, that the condenser was being charged and discharged once for every alternation. Under these conditions the high-frequency current should be proportional to \sqrt{C} , and the square of the current proportional to C . The curve obtained shows

this to be approximately the case, except that an intercept is noted at the point corresponding to two jars due to the fact that for such a low capacity the gap could not be kept from arcing, which, in turn, prevented the periodic and regular charging and discharging of the condenser.

Design of Audio Circuit.—We may now discuss more fully the choice of the various parts of the so-called “audio circuit,” which comprises the alternator, the variable reactance, the step-up transformer, the choke

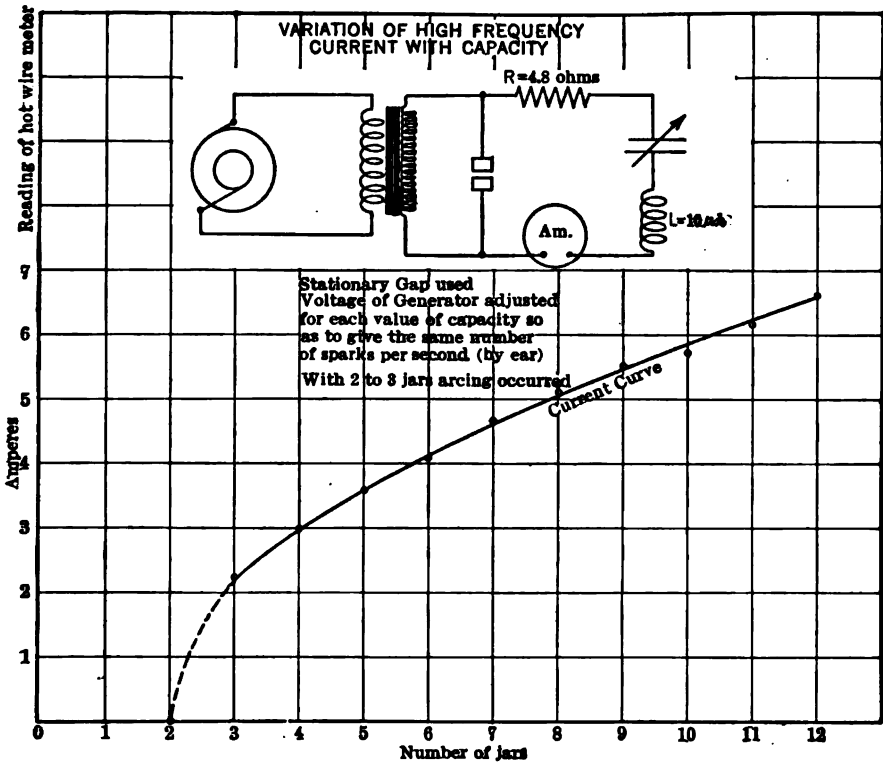

FIG. 16.—Variation of the high-frequency oscillatory current with the amount of capacity used.

coils, and the condenser. This circuit may be simplified by noting that a transformer may be treated approximately as a simple circuit consisting of an inductance and a resistance entirely transferred to the high- or to the low-tension side; furthermore, any impedance in the secondary circuit may be transferred to the primary by multiplying by a suitable factor. On this basis the audio circuit may be simplified to that of Fig. 17,

where

A = alternator armature, having both resistance and inductance:

- R_t = resistance of both transformer coils transferred to low-tension side;
 L_t = leakage inductance of both transformer coils transferred to low-tension side;
 R_p = resistance of protective choke coils transferred to low-tension side;
 L_p = inductance of protective choke coils transferred to low-tension side;
 C = condenser capacity transferred to low-tension side;
 R_v = resistance of variable reactance coil in low-tension side;
 L_v = inductance of variable reactance coil in low-tension side.

The circuit of Fig. 17 may be still further simplified to that of Fig. 18, where

- A = alternator *without* inductance or resistance;
 R = resistance of entire circuit, including alternator armature, transformer coils, protective choke coils, variable reactance coils, on basis of low-tension side;
 L = inductance of entire circuit (ditto);
 C = capacity of condenser transferred to low-tension side.

It has already been stated that this circuit should be adjusted

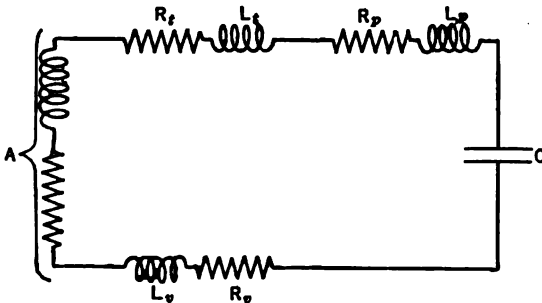

FIG. 17.—An approximate simplification of the low-frequency circuit of a radio transmitter.

so that it will have a natural frequency about equal to that of the alternator; it has also been shown how the capacity of the condenser may be calculated if the voltage to be used and the power required are known; it follows then that, knowing the capacity, the value of the total in-

ductance L in the circuit of Fig. 18 may be easily calculated from formula:

$$f = \frac{1}{2\pi\sqrt{LC}}$$

and this inductance may then be apportioned between the alternator, the variable reactance, the transformer, and the choke coils. An example of this calculation has already been given on page 296, where the compu-

tations have been based on the high-tension side of the transformer. The same computations will be repeated on the basis of the low-tension side.

Assume that the transformer ratio is 1 : 80; then, any inductance or resistance in the high-tension side may be transferred to the low-tension side by dividing by 80^2 , or 6400, while a capacity in the high-tension side may be transferred to the low-tension side by multiplying by 6400.

In our case:

Capacity of condenser in high-tension side = $0.012 \mu f$. Hence, equivalent low-tension capacity = $0.012 \times 6400 = 77.0 \mu f$.

If the audio-circuit must resonate at 500 cycles per second,

Total equivalent low tension inductance

$$= \frac{1}{500^2 \times 4\pi^2 \times 77.0 \times 10^{-6}} = .00133 \text{ henry.}$$

This value of inductance should be $\frac{1}{6400}$ of that found on page 296, i.e., 8.5 henries; thus:

$$\frac{8.5}{6400} = .00133 \text{ henry.}$$

Of this inductance probably the largest part is, in a modern set, found in the alternator, while the transformer has comparatively little inductance, and the balance is made up by the choke coils in the high-tension side and the variable reactance *V.R.* in the low-tension side.

In order to show the manner in which the whole audio circuit may be made to resonate the curves of Fig. 19 are here given as being representative of an actual set. In obtaining these curves the field current and speed of the alternator were kept constant, while the capacity in the high-tension side of the transformer was changed with the circuit connections as shown in Fig. 20. Under these conditions, as the capacity, and, therefore, the natural frequency of the circuit, was varied, the current in the primary of the power transformer as well as the voltage across it varied and reached a maximum at the point corresponding to resonance conditions. A capacity of about 5.5 Leyden jars is seen to have produced resonance. In an actual set the adjustment of the capacity, or of the inductance, is made about 20 per cent to 30 per cent larger than necessary to give resonance at audio frequency, thus making the natural frequency of the circuit somewhat lower than the alternator frequency. This point will be more fully emphasized further on. In the case

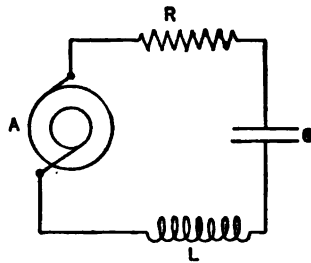

FIG. 18.—Simplest possible representation of the low frequency circuit, not quite equivalent to the actual circuit.

represented by the curves of Fig. 19 the set was actually operated with 8 Leyden jars across the secondary.

It now remains to investigate, as far as the conditions will allow, the transient phenomena taking place in the audio circuit as the condenser

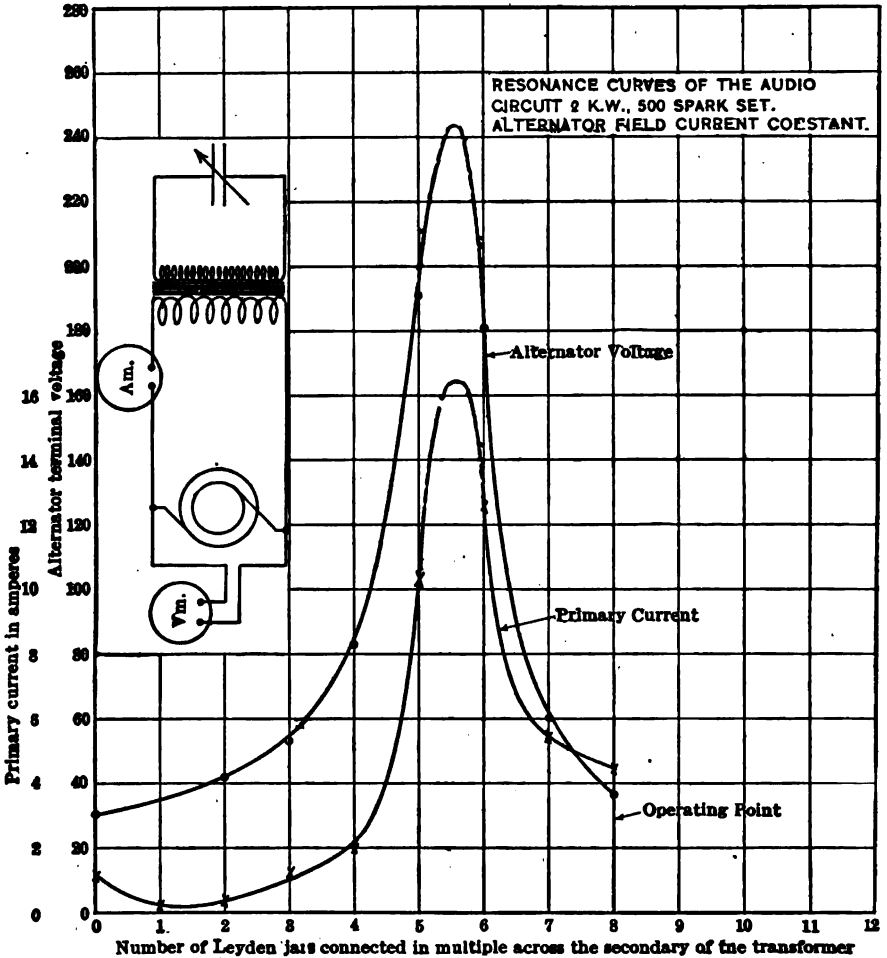

FIG. 19.—Variation of alternator voltage and primary current of a 2 k. w. spark transmitter as the capacity in the secondary of the transformer was varied; field current of alternator and speed held constant. Gap set too long to permit sparking at voltage of test.

is charged and discharged; we especially mean to refer to the variation of the condenser current and voltage as the alternator e.m.f. is impressed upon the audio circuit and, thereafter, as the gap breaks down. As shown in Fig. 18, we are dealing with an oscillatory circuit, having the resistance, inductance, and capacity R , L , and C , respectively, upon which there is

impressed a harmonic e.m.f. The equation for the instantaneous value of current for such a circuit (Eq. (79)) was derived in Chapter IV, page 252, and is

$$i = \frac{E}{\sqrt{R^2 + \left(pL - \frac{1}{pC}\right)^2}} \sin(pt - \phi) + A e^{-\frac{Rt'}{2L}} \sin \omega t', \quad \dots (6)$$

- in which p = angular velocity of impressed force;
- ω = angular velocity of natural oscillations of the circuit;
- ϕ = phase difference of E and I in the steady state;
- A = a constant to be determined;
- t' = time of duration of the transient term.

In deriving this equation (page 254) it was shown how to solve for A and t' , these depending for their value on the time the voltage is introduced into the circuit. In a radio set there is no switch actually used, but the equivalent effect is caused by the operation of the spark gap; when the gap is sparking its resistance is so low that the secondary of the power trans-

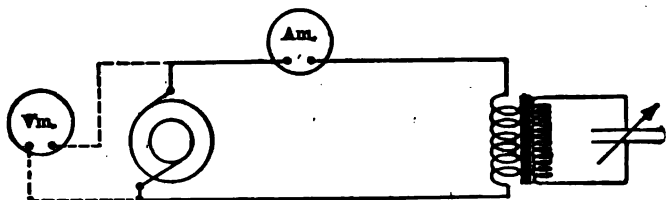

FIG. 20.—Circuit used in getting curves of Fig. 19.

former is short-circuited and this is the condition for comparatively small current in the armature circuit. When the gap opens (ceases to carry current) the effect of the condenser of the closed oscillating circuit is to so neutralize the inductance of the transformer and armature that the current rises to comparatively large values. We may get a fair idea of the behavior of the actual radio circuit, therefore, by supposing that Eq. (6) holds good, the voltage, $E \sin pt$, being introduced into the circuit at the instant when the gap opens. As mentioned when analyzing the action of this circuit before (page 258) the general solution is difficult, but we can get fairly easy solutions if we assume that the condenser is completely discharged at every oscillation and that the gap opens when the voltage of the generator is zero; this latter condition may be approximately satisfied by suitable adjustment of the set.

Assuming that the low-frequency circuit is resonant to the alternator voltage, that the gap opens when generator voltage is zero, and that the condenser is discharged, Eq. (6) becomes

$$i = \frac{E}{Z} \sin pt - \frac{E}{Z} e^{-\frac{Rt}{2L}} \sin \omega t = \frac{E}{R} \sin pt \left(1 - e^{-\frac{Rt}{2L}}\right). \quad \dots (7)$$

From this we find the voltage across the condenser; it is

$$v_c = \frac{E}{pCR} \left\{ -\cos pt + \frac{\epsilon^{-\frac{Rt}{2L}}}{p^2 + \left(\frac{R}{2L}\right)^2} \left(\frac{R}{2L} \sin pt + p \cos pt \right) \right\},$$

which when $\left(\frac{R}{2L}\right)^2$ is small compared to $(p)^2$ gives

$$v_c = \frac{E}{pCR} \left\{ \frac{R}{2pL} \epsilon^{-\frac{Rt}{2L}} \sin pt - \cos pt \left(1 - \epsilon^{-\frac{Rt}{2L}}\right) \right\}. \quad \dots \quad (8)$$

This equation shows that the condenser voltage rapidly changes its phase during the first few alternations, the $\sin pt$ term predominating at first, the $\cos pt$ term being zero; as soon as $\epsilon^{-\frac{Rt}{2L}}$ departs appreciably from unity the $\cos pt$ begins to predominate and this continually increases with increasing time due to the increasing value of $\left(1 - \epsilon^{-\frac{Rt}{2L}}\right)$. Thus in the steady state ($\epsilon^{-\frac{Rt}{2L}} \cong 0$) Eq. (8) reduces to the familiar form $v_c = -\frac{E}{pCR} \cos pt$.

The curves of Fig. 21 show the form of current and voltage across the condenser for a typical circuit, the values of the various constants being noted on the curve sheet. It will be noticed that the condenser voltage reaches its maximum values at approximately the times when the impressed voltage is zero, and hence the spark gap will break down at about this time; the resulting oscillatory current in the closed oscillating circuit at once discharges the condenser the spark gap opens and the voltage of the alternator, passing through its zero value is again impressed on the circuit to produce the next transient. It is to be seen that if events follow the order given here the assumed condition ($e=0$ when gap opens) is satisfied.

It is found in practice that the condition of resonance assumed in this analysis tends to produce irregular sparking, giving the signal a ragged note, so actually the natural frequency of the circuit is made about 20 per cent lower than the frequency of the alternator. On the assumption that the spark gap again opens when the generator voltage is passing through zero the curves of Fig. 22 have been constructed for the same circuit as used for Fig. 21 with the exception that the capacity has been increased from $20\mu f$ to $30\mu f$, this giving about the same amount of de-tuning as is used in practice.

For this case the form of current and condenser voltage are obtained by the use of Formulæ (80)–(83) of Chapter IV. Supposing that the gap opens the circuit at the instant the circuit voltage (that produced by the alternator) is zero and increasing, it is found that for the steady

state the current should be -23.5 amperes and the voltage across the condenser should be -92 volts. To satisfy the condition that the actual current must be zero as well as the drop across the condenser a transient term must be added to the steady state solution; by the process outlined in Chapter IV this transient is found to be satisfied by charging the condenser to -385 volts and starting this transient term .000756 second before the alternator voltage goes through its zero value—this transient term has the natural frequency of the circuit (given practically correct

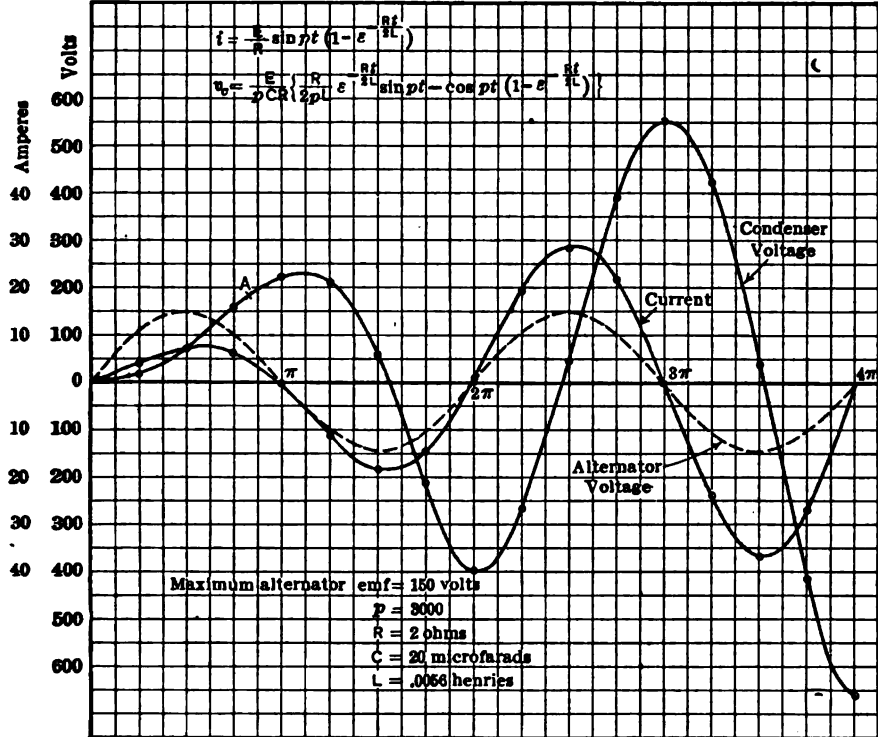

FIG. 21.—Transient current in audio circuit of a spark transmitter, circuit tuned to alternator frequency.

by putting $\omega = \left(\frac{1}{\sqrt{LC}} \right)$ and a damping fixed by the R and L of the circuit. The actual current is obtained by taking the sum of the steady term and transient term and is

$$i = \frac{150}{\sqrt{2^2 + \left(3000 \times .0056 - \frac{10^6}{3000 \times 30} \right)^2}} \sin (3000 t - 70^\circ.7) + 28.2 e^{-\frac{2(t+.000756)}{2 \times .0056}} \sin \{ 2440(t+.000756) \}$$

Similarly the equation for voltage drop across the condenser is found to be represented by the equation

$$V_c = \frac{150 \times 10^6}{3000 \times 30 \sqrt{2^2 + \left(\frac{3000 \times .0056}{3000 \times 30} \right)^2}} \sin \left(3000 t - 70^\circ.7 - \frac{\pi}{2} \right) - 385 \epsilon^{-\frac{2(t+.000756)}{2 \times .0056}} \cos \{ 2440(t+.000756) \}$$

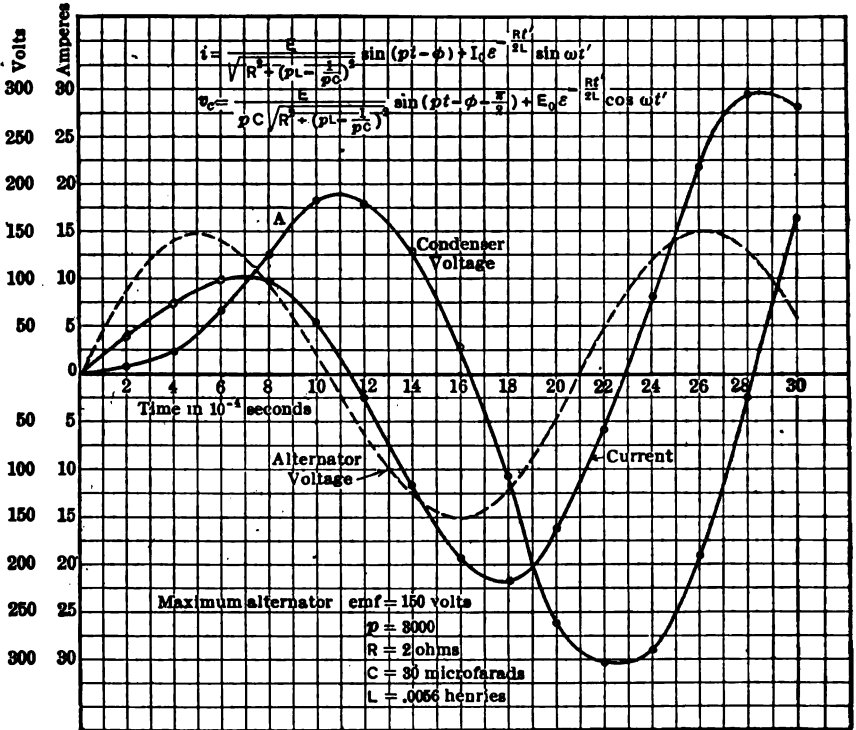

FIG. 22.—Transient current in audio circuit of a spark transmitter, circuit frequency being about 40 per cent lower than alternator frequency.

It may be seen from Fig. 22 that the voltage across the condenser is rising more rapidly, at times $t = \pi$, than was the case for the resonant condition depicted in Fig. 21; it is quite likely this more rapid rise in condenser voltage, by causing the spark to take place at a more definite time, accounts for the more regular behavior of the spark when the circuit is detuned as supposed in Fig. 22, than when the circuit is resonant.

In Figs. 21 and 22 the forms of current and condenser voltage have been shown for nearly two cycles; actually if a spark occurs at the time indicated by the letter A on the condenser voltage curve (which is the time the spark should actually occur) the condenser voltage drops to zero

and it, as well as the current, goes through the same changes from π to 2π as it did from 0° to π . The actual forms of the condenser voltage for the circuits analyzed in Figs. 21 and 22 are shown in Figs. 48 and 49 of Chapter IV, page 259). It will be seen that the above analysis does give fairly accurate results.

Types of Spark Gaps.—The construction of the several commercial types of spark gaps in use at the present time may be conveniently subdivided into the following classes:

- | | |
|------------------|--|
| (a) Open gap. | |
| (b) Rotating gap | $\left\{ \begin{array}{l} \text{synchronous} \\ \text{nonsynchronous} \end{array} \right.$ |
| (c) Quenched gap | |
| | $\left\{ \begin{array}{l} \text{self-cooled} \\ \text{fan-cooled.} \end{array} \right.$ |

The Open Gap and Operating Conditions.—Fig. 23 below illustrates one form of the open gap. This type is also known as a plain spark discharger.

In considering the requirements which such a gap must fulfill, it is desirable to review briefly that part which it plays in the production of high-frequency oscillations. It will be recalled that a high voltage is impressed on the gap and condenser-inductance circuit connected in parallel, and at a certain critical voltage, the insulation of the dielectric, usually air, between the terminals, breaks down, and permits a high-frequency oscillatory discharge to take place. The gap must therefore possess high dielectric strength or resistance to puncture, previous to breakdown so that the condenser may be charged to a high potential difference, as otherwise the high-frequency energy is reduced, and the efficiency of the transmitter is lowered, due to the breakdown occurring at too low a voltage.

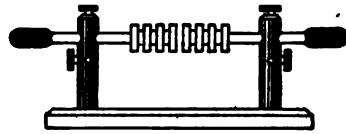

FIG. 23.—Small open spark gap having cooling vanes on the spark knobs.

After the gap has broken down it must possess a very low resistance, otherwise the damping of the oscillations will be excessive, and the transmitter inefficient, most of the energy being dissipated as I^2R loss in the gap. The gap must be conducting only during the interval of the passage of a wave-train. If we assume a 300-meter wave and a decrement of .2, the duration of the train is .000024 second. The time during which the gap is conducting is thus very small. If we consider 1000 wave-trains per second, the period between trains is $.001 - .000024 = .000976$ second, and in this period the gap must recover its insulating properties. These figures indicate the short time intervals involved in the functioning of

the gap, and special precautions must be taken to insure satisfactory operation.

Open Gap—Requirements for Satisfactory Operation.—*First.*—The gap electrodes and dielectric between them should remain cool. This will assist to prevent arcing and permit the gap to return quickly to its condition of high dielectric strength. It will be recalled that a cumulative ionization (ionization by impact) causes the gap suddenly to become a conducting medium, and that an extremely rapid de-ionization causes the dielectric between the electrode to become a good insulator again. If the dielectric is hot, this de-ionization is hindered and delayed, and the gap may be conducting after the high-frequency discharge has passed. Under this condition an arc current will flow, that is, arcing occurs and the voltage across the gap will be unable to increase. No energy, or at best, very little energy, will thus be stored in the condenser. Also the gap electrodes will be rapidly eaten away under the arcing conditions, requiring frequent cleaning and adjustment.

For these reasons cooling flanges are usually provided, or a blast of air may be blown through one electrode. In this latter case the electrode may be supported on a hollow shaft, through which the cooling air is blown, leaving the electrode through perforations in the sparking surface.

The air blast also assists the gap to return to its high resistance condition by blowing away the ionized air.

Second.—The electrodes should be constructed of non-arcing metal, such as zinc or magnesium, in preference to copper, which represents an arcing metal.

Open Gap—Operation and Adjustment.—This gap is intended only for the smaller, low-powered sets, due to the difficulty of preventing arcing and irregular discharges (partial discharges). The amount of energy radiated is small, and the signal note received may not possess a clear tone, due to the irregular timing of the wave trains sent out. On the low-powered set, the charging voltage is rather low, in the neighborhood of 2000 volts, and the gap separation is very small (about .02 inch). It is therefore important that the gap separation be easily adjustable and that means be provided for rigidly holding the electrodes in position when once set. The electrodes are usually very heavy and massive to assist in conducting away the heat, and are provided with large sparking surfaces, so their replacement is not required at frequent intervals. It should be noted, however, that the replacement of defective electrodes should not be made difficult, but the gap designed with their removal and renewal in mind.

With the small separation mentioned above, it is also important to have the gap faces properly aligned. If this is not done, the spark will always jump at the same point, and the electrodes will be consumed

more rapidly at this point. It is desirable that the wear on the gap faces be uniform, as in this way the most effective use of the electrodes will be secured. In addition to alignment, it is essential that the faces be clean and polished. If they are neglected, oxide, dust, and dirt, etc., will collect, and form an uneven surface. The spark will jump wherever the surfaces may be closest together, and thus for this condition also the sparks occur at a particular spot on the electrode. Since the oxide or dirt is not metal, it will not conduct the heat away as rapidly as required. A hot spot will thus be formed, causing arcing to take place, and operation to be inefficient and unsatisfactory.

The following table indicates approximate minimum discharge voltages required for sphere gaps of 2.5 cm. and 1.0 cm. radius in air at atmospheric pressure:

TABLE I

Gap Length in Cm.	MINIMUM DISCHARGE, VOLTS.		Gap Length in Cm.	MINIMUM DISCHARGE, VOLTS.	
	R = 2.5 Cm.	R = 1 Cm.		R = 2.5 Cm.	R = 1 Cm.
.1	5,000	5,000	1.0	33,000	31,000
.2	8,500	8,000	1.1	35,500	33,500
.3	12,000	11,000	1.2	38,400	35,200
.4	15,000	14,000	1.3	41,000	37,000
.5	19,000	17,500	1.4	43,600	38,500
.6	21,500	20,000	1.5	46,000	40,000
.7	25,000	23,000	2.0	56,000	44,000
.8	27,500	27,000	3.0	74,000	50,000
.9	30,000	29,000			

Open-gap Limitations.—As previously mentioned the open gap is inherently limited in application to small power sets, due to the impossibility of preventing arcing, and also the small number of breakdowns permissible per second (group frequency) without causing excessive arcing. It will be recalled that the high-frequency power equals $\frac{1}{2}NCE^2$, wherein N is the group frequency, and thus the low-group frequency to which the open gap is limited causes a corresponding decrease in the high-frequency power, which may be generated by the set.

Synchronous Rotating Gap—Construction and Operation.—The construction of the synchronous rotating gap is indicated in Fig. 24, where the rotating electrode shown is simply a toothed wheel, rigidly fastened to the alternator shaft. The spark jumps from one fixed electrode to the disk, through the disk and thence back through the second gap to the other electrode.

The position of the disk on the shaft is adjusted permanently so that the teeth line up with the fixed electrodes at the time of maximum values

(positive and negative) of the voltage wave, and the gap separation adjusted so, that the breakdown voltage is slightly below the maximum voltage. Under these conditions the gap breaks down once during each half cycle, and assuming a 500-cycle supply, the group frequency is evidently 1000. The number of teeth on the disk is determined by the number of alternator field poles. For instance, if the alternator be equipped with 24 poles, the disk would have 24 teeth, and 24 breakdowns would occur per revolution. This would correspond to an alternator speed of 2500 r.p.m. if a group frequency of 1000 were desired.

Clearly, the number of breakdowns per revolution may be controlled by substituting disks with different tooth spacing. Thus, we could omit

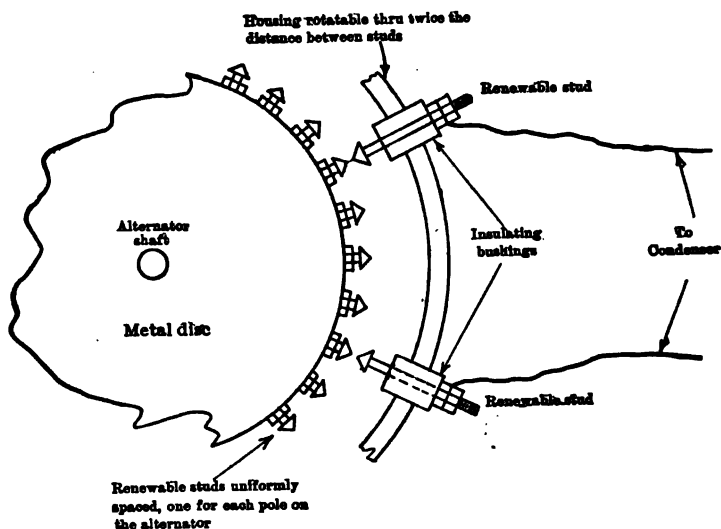

FIG. 24.—Arrangement of parts of a synchronous rotating gap; instead of using a metal disk for the rotating member this is, sometimes made of a disk of bakelite or similar material, the rotating studs being then all connected together by a metal strip.

alternate teeth, and cut the group frequency in half, etc. The tone of a signal may thus be altered easily and quickly, in case this is found desirable due to interference effects present. The quality of the note may be made quite distinctive by introducing regular irregularities in the arrangement of teeth as, e.g., omitting every third tooth.

The action of the gap, assuming one breakdown to occur every half cycle is indicated conventionally in Fig. 25. Actually the condenser voltage is not a sine wave, but has the peculiar form shown in Figs. 21 and 22.

Synchronous Gap Application.—The synchronous gap possesses a low operating resistance, due to the electrodes being close together at the time of discharge, and automatically recovers its insulating properties between

discharges due to the electrodes being widely separated during this interval. Arcing is prevented by the separation of the electrodes increasing as the wave train passes, and also by the fanning and cooling action of the rapidly moving electrodes. Partial discharges cannot occur, as the gap separation may be adjusted for breakdown near the voltage maximum. This form of gap will successfully handle large amounts of power and high spark frequencies, and is at present widely used on commercial spark transmitters of large capacity.

Non-synchronous Gap—Operation and Application.—The non-synchronous gap is essentially similar to the synchronous rotary gap described above, with the exception that the moving electrode disk is not attached to the alternator shaft, but is driven by an independent motor. If the

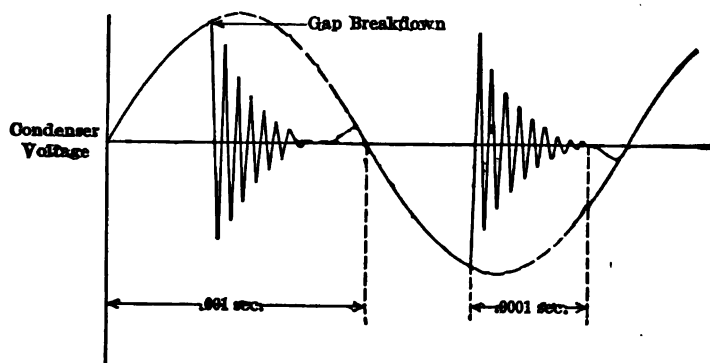

FIG. 25.—Conventional representation of audio and radio frequency currents; actually the voltage across the condenser does not have the sinusoidal shape given here but has the form given in Figs. 21 and 22.

motor runs at exactly synchronous speed, and the phase relation is correct, the operation will be equivalent to the synchronous type.

This, however, is an unusual condition, and one which would be difficult to maintain for any length of time. Normally the disk is run at speeds greater than synchronous, the gap separation being adjusted for some voltage somewhat less than the peak value. The action under these conditions is shown conventionally in Fig. 26.

It will be noted that several breakdowns may occur during each half cycle and that the voltage at which breakdown occurs is not of a definite nor constant value. Thus the wave-trains do not occur at regular intervals, nor is the energy of the several discharges the same. The received signal is therefore of a higher pitch, and of a different musical quality than that produced by the synchronous type. It finds its greatest application for those installations where commercial frequencies only are available as a supply. A 60-cycle service may thus be used to supply a transmitter

radiating, by means of the non-synchronous gap, in the neighborhood of 1000 groups per second. The power radiated is thus greatly increased and the tone high enough to make the ear and telephone both more efficient than they would be with a 60-cycle note; the result is a material increase in the range of a station.

Quenched Gap.—The property which a gap possesses of returning very quickly to its un-ionized condition is termed “quenching.” In the rotating gaps, quenching is obtained principally by the air blast which occurs at the sparking contacts, and also to some extent perhaps by the high velocity of the moving electrodes, thus preventing arcing and permitting the voltage to build up again across the condenser, as already noted. Rapid quenching also possesses additional advantages as discussed on page 247.

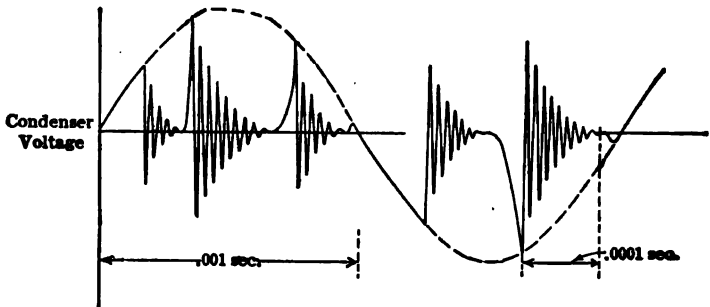

FIG. 26.—Conventional illustration of the action of a transmitter set having a non-synchronous rotating gap.

In place of a mechanical quenching action, as illustrated by the rotary gaps, an electrical quenching type is also widely used, which is known as the “quenched gap.” In this type, the return of the gap to a condition of high dielectric strength is obtained through very rapid de-ionization of the gap between the electrodes. The construction of a typical gap is shown in Fig. 27. The following description of its action will explain the peculiar cellular form of construction illustrated.

Quenched Gap—Requirements for Rapid De-ionization.—For the gap to operate satisfactorily, that is, return to its un-ionized condition in an extremely short time, the following conditions must be fulfilled.

1. The spark must take place in a space in which no oxide is formed. This is because the oxide will deposit on the sparking surface of the gap and soon short-circuit it.

2. The metal surfaces must be kept cool and the electrodes must therefore be good heat conductors. Silver or copper are the metals which best fulfill this requirement. Usually silver-plated copper electrodes are employed.

3. No part of the gas which forms the gap dielectric must be far from a cool metal surface, that is, a very short gap only may be used.

Quenched Gap—Construction.—The above requirements are satisfied in the commercial form of gap as follows:

1. The spark takes place in an air-tight chamber. The several elements or sections of the gap are separated from one another by the insulating gaskets as shown (Fig. 28A) and the whole clamped tightly together. When the gap is first operated, the air, which is initially between the gap faces, becomes separated into its elements, mainly oxygen and nitrogen, the

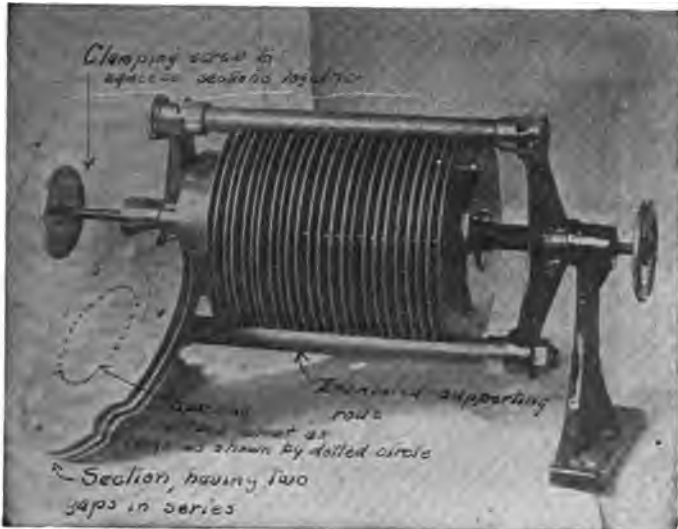

FIG. 27—Photograph of a commercial type of quenched gap; three disks clamped together by insulating screws make up a unit, there being two gaps in series per unit.

oxygen combining with the copper electrodes to form copper oxide, thus leaving an atmosphere of essentially pure nitrogen between the gap faces. The black oxide of copper disappears after the gap has been in operation a short while, the gap faces being found bright and clean if the gap is disassembled for inspection. (The exact reason for the disappearance of this oxide is not apparent—it is probably absorbed into the material of the separating gasket, under conditions present when the gap is in operation.)

2. In addition to using good heat-conducting materials, such as silver and copper, for the electrodes, the efficient cooling of the gap is assisted by means of cooling vanes or fins, which radiate the heat produced during the operation of the gap. These fins are clearly indicated in the diagram

(Fig. 27). There has been recently developed a staggered form of gap construction, which permits air circulation on both sides of each element.

This construction, whereby cooling is accomplished by increased radiating surface, represents what is known as the self-cooled type. It is sometimes necessary, with the higher-powered sets, to supply a small motor driven fan to cool the gap satisfactorily.¹ This form may be of the type illustrated in Fig. 28, where the gap is supported in a trough of insulating material, the cooling air blast provided by the motor-driven

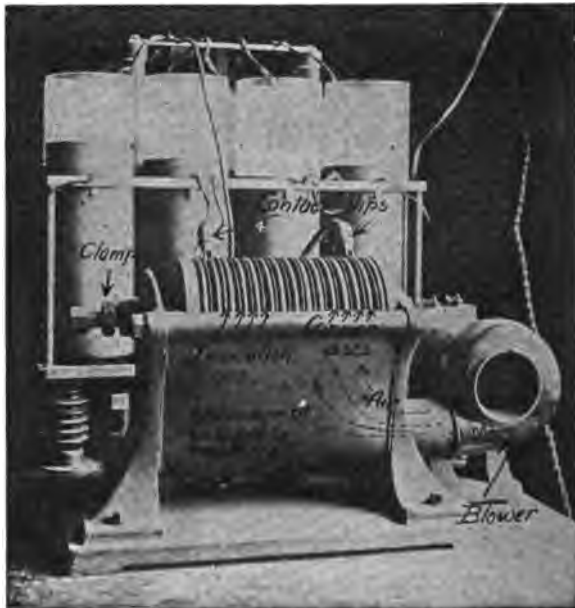

Fig. 28.—Another type of quenched gap in which each copper disk is assembled separately; the small blower forces cool air around the cooling vanes to prevent overheating.

fan, coming up through the trough, and thus effectually cooling the gap. The cross-sectional detail of this gap is indicated in Fig. 28A.

3. The requirement that no particle of gas in the gap shall be remote from a metal surface is satisfied by subdividing the gap into sections, the number of sections increasing as the "break-down" voltage value is increased. Each gap provides somewhat less than .01 inch separation, with a breakdown voltage of approximately 1200 volts. Thus no particle of gas in the gap is more than .005 inch away from the metal, and the gap is rapidly de-ionized. This rapid de-ionization is due principally to the loss of electrons by diffusion, although recombination of electrons and positive ions is also a factor. By loss of electrons by diffusion is meant

¹ Most modern gaps receive their supply of cooling air from a fan mounted on the alternator shaft, thus dispensing with the extra motor required for blower.

the removal of electrons from the gas to the face of the gap, due to the attraction of the induced positive charges on the gap faces. As the most distant electron has only a short distance (.005 inch) to go before arriving at the gap face and the attracting charge, the time required is extremely small.

Quenched Gap—Application.—The quenched gap is used on spark transmitters of all powers, from the very small sets used in military field work and aeroplanes, up to the 500–600 h.p. (Input) equipment at the Nauen Station (Telefunken System). Quietness in operation, small space requirements, simplicity, and desirable operating characteristics (see page 324) are the particular advantages of this type of gap.

The Chaffee Gap¹—Construction.—The construction of this gap is quite similar to that of the quenched gap described above. The electrodes consist of a copper anode and an aluminum cathode, the spark occurring between them in an air-tight chamber containing an atmosphere of moist hydrogen. One electrode is mounted on a flexible diaphragm to permit adjustment of the gap length, while the other is held fixed in a bakelite mounting as indicated. As with the quench gap, it is highly important that the electrodes and gap faces be kept cool, hence the large radiating fins with which each electrode is equipped.

Operation of the Chaffee Gap.—This gap is supplied from a d.c. source through resistances and high-frequency choke coils as shown in Fig. 29,

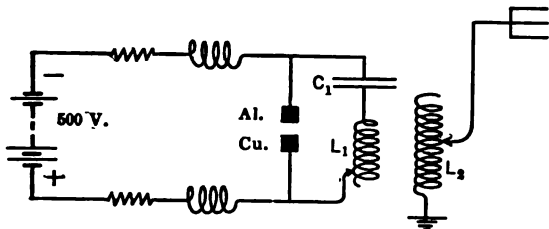

FIG. 29.—Circuit used with Chaffee type of quenched gap, by which the high-frequency current is maintained by impulse excitation.

One of these impulses sets the secondary circuit into oscillation, the retro-action of which sets off successive primary impulses at the proper time for maintaining the oscillations in the secondary. These secondary oscillations are not constant in amplitude, but grow to a maximum

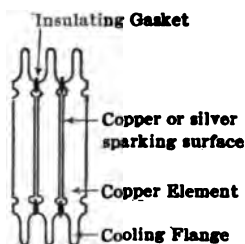

FIG. 28A.—Cross-sectional sketch of part of the gap shown in Fig. 28.

and is connected in shunt with the oscillating circuit C_1L_1 . Normally the gap separation is 2 or 3 mm. and under these conditions the gap acts as a rectifier, permitting current pulses to flow in one direction only, e.g., from the copper to the aluminum electrode.

¹ This is only one of several gaps of this general type which have been developed in recent years. Tungsten is quite a favorite metal for making the terminals

amplitude in one or two cycles, and decay thereafter more or less quickly. Normally the current consists of distinct groups of trains of waves separated by a few cycles only; under certain conditions (high secondary resistance) the trains join, and the current then is a high-frequency oscillation, the amplitude of which periodically rises and falls.

This gap has not been extensively employed up to the present time, as the power limitations do not permit its application to the higher powered stations. Thus one gap is capable of 200 watts input. It is to be noted that several gaps may be connected in series, the power rating increasing as the square of the number of gaps used.

Oscillation Transformer.—As previously noted, the function of the oscillation transformer is to transfer the high-frequency power from the

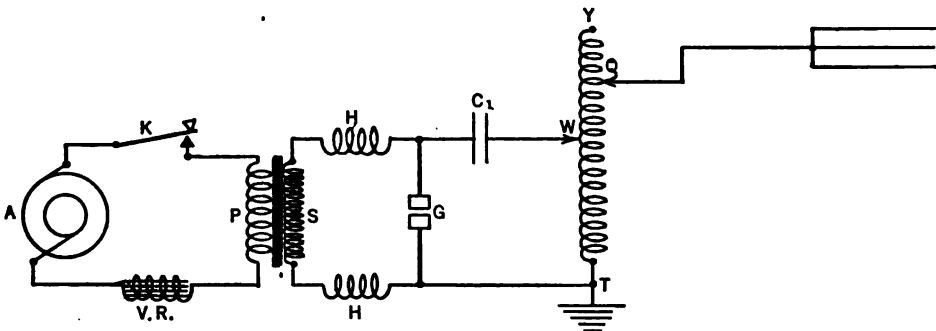

FIG. 30.—For small portable sets the oscillation transformer is sometimes made with only one coil as shown here.

closed circuit to the open or antenna circuit; it is, in other words, a transformer of high-frequency currents or oscillations. Because of these it is important that it be constructed without iron core or other masses of any metal whatever, for the hysteresis and eddy current losses would be so large as to make the transformer efficiency very low.

Two general types of oscillation transformer are available, i.e., (a) the two-coil type, (b) the single-coil type. As the names imply, the two-coil type is made up of two separate and distinct coils more or less separated from each other, while the single-coil type consists of a single coil connected as shown at *YQWT* in Fig. 30.

In the figure above, *WT* represents the part of the oscillation transformer in the closed circuit, while *QT* is the part used in the open circuit. It will be seen that here we have what is known in general electrical engineering as an "auto-transformer," which, in turn, is a modification of the simple transformer. The practical construction of the oscillation transformer varies widely with different makes. In every case means must be provided for changing the number of turns in the closed circuit

and in the open circuit and also (in the case of the two-coil transformer) for changing the position of one coil relative to the other. As regards the former of these two requirements two general methods are used: one consists of using a clip as shown in Fig. 31, and shifting this by hand until the required number of turns is obtained; and the other consists of a roller contact which is rotated by means of a suitable handle so as to make contact with different turns as shown in Fig. 32.

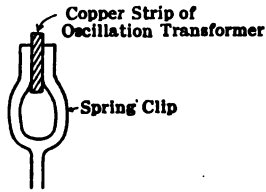

FIG. 31.—For making connection at any desired point on the coils of an oscillation transformer a spring clip of this form is useful.

The changing of the position of one coil relative to the other may be accomplished by any one of several methods, two of which are represented by Figs. 33 and 34, which are self-explanatory. These figures also show the general construction of the various types of transformers; in all cases either ribbon or braided copper is used, and is supported in various ways as shown by the illustrations.

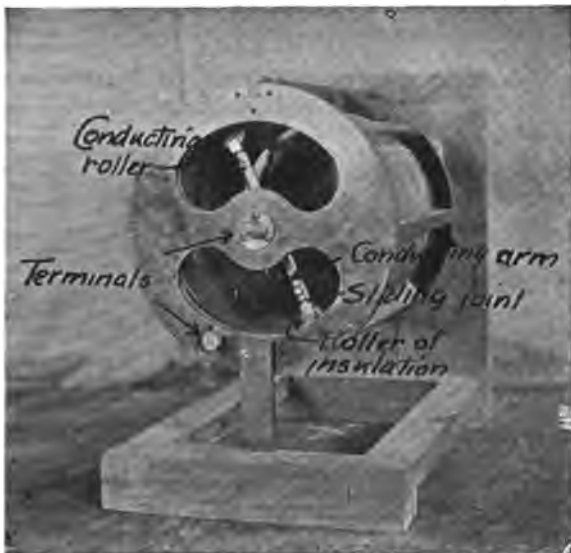

FIG. 32.—An adjustable transmitting coil is sometimes made with a rolling contact; on the opposite end of the arm is placed a roller of some insulation material to avoid having a short circuited half-turn which would occur if both rollers were conductors.

The variation of the coefficient of coupling between the closed and open circuits is accomplished, in the case of the two-coil transformer, by changing the position of the two coils relative to each other and also changing the inductances outside of the transformer coils; in the case of

the single-coil type, the coefficient of coupling is changed by changing the number of turns WT (Fig. 30), which are common to both circuits, and

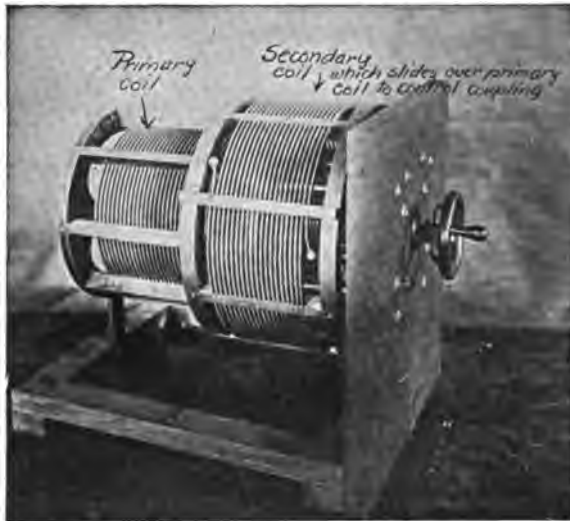

FIG. 33.—A type of oscillation transformer in which one coil telescopes with the other to vary coupling.

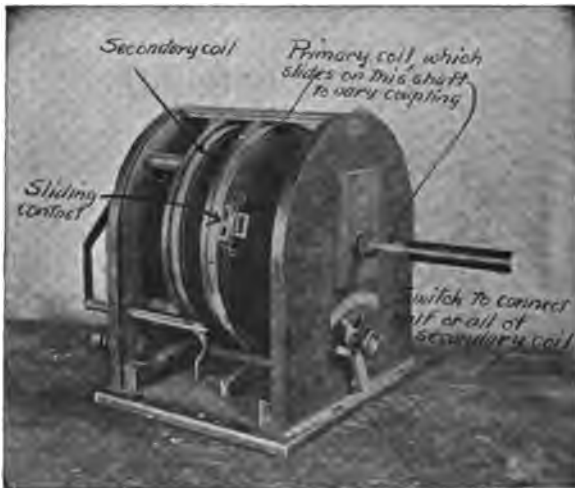

FIG. 34.—An oscillation transformer made of flat spirals; variation of coupling is obtained by sliding one of the coils back and forth on the central shaft.

also by changing the position of the point Q on the loading inductance in the antenna circuit.

It must be remembered that, in the case of the two coil type:

$$k = \frac{M}{\sqrt{L_1 L_2}},$$

where

k = coefficient of coupling;

M = mutual inductance between the two coils of the oscillation transformer;

L_1 = total inductance in the closed circuit;

L_2 = total inductance in the open circuit,

and in the case of the single coil type,

$$k = \frac{L}{\sqrt{L_1 L_2}},$$

where

L = inductance common to both circuits.

k, L_1, L_2 have the same significance as above.

The Radio-frequency Circuits.—This consists of the closed and open oscillatory circuits, coupled together through the oscillation transformer. The whole of the radio-frequency circuit for a two-coil oscillation transformer is shown in Fig. 35. The closed and open circuits are tuned to the same frequency.

The theory applying to the above is that which has been discussed in connection with two inductively couple oscillatory circuits (see Chapter IV, pages 226–246). The main point to be considered is that when the two circuits are closely coupled there are produced in each two currents of frequencies differing from the natural frequency of the two circuits; when the natural frequencies of the circuits are the same, then the frequency and wave-length of the component currents are given by (see Chapter IV, pages 229–231)

$$f'' = \frac{f}{\sqrt{1-k}}, \quad \lambda'' = \lambda\sqrt{1-k},$$

$$f' = \frac{f}{\sqrt{1+k}}, \quad \lambda' = \lambda\sqrt{1+k},$$

where

f and λ = natural frequency and wave-length of either circuit;

f' and λ' = frequency and wave-length of one of the component currents;

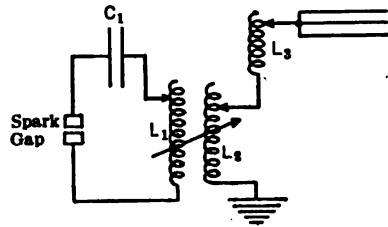

FIG. 35.—The two coupled radio frequency circuits of a spark transmitter.

f'' and λ'' = frequency and wave-length of the other component currents;
 k = coefficient of coupling.

The relative amplitudes of the two currents have been discussed in Chapter IV, pages 230–237; generally the higher-frequency current has the greater amplitude. Furthermore the higher-frequency currents of the primary and secondary are about 180° apart, while the lower-frequency currents of the primary and secondary are about in phase. The effect of all this is to produce current “beats” in the primary and secondary with a frequency equal to the difference of the frequencies of the component currents; again, while the resultant current in the primary is pass-

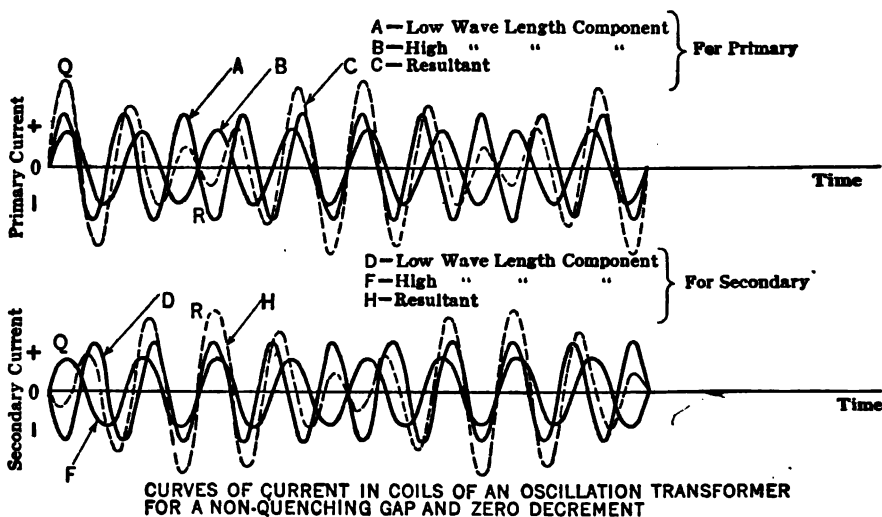

FIG. 36.—Currents in the two circuits of Fig. 35, no damping assumed.

ing through the small amplitude values of the “beat cycle,” the secondary current is passing through the high amplitude values of the “beat cycle,” and vice versa. This is illustrated by the curves of Fig. 36, where the dotted line curves represent the resultant primary and secondary currents; it will be noted that the primary resultant current starts with a high amplitude at *Q* and decreases to a low amplitude at *R*, while the secondary resultant current does just the opposite. In plotting the curves it has been assumed that neither circuit suffers any losses, and the result is that the decrement of the component currents is zero, while the resultant currents would also periodically repeat themselves through the “beat cycle” without any decay. This of course is not true of an actual case, where, on account of the losses in both circuits, the decrement would have a definite value, and the resultant currents would “decay” somewhat as

shown in Fig. 37, which represents the component and the resultant primary and secondary currents for circuits with decrements. Another assumption made is that the gap used is such (open-spark gap) that it remains closed for considerable time after its breaking down, so that the currents may flow through the closed circuit.

The phenomenon of the "beats" takes place most pronouncedly when the coupling between the primary and secondary of the oscillation transformer is closest. For loose coupling the two circuits oscillate at very nearly a single frequency equal to their natural frequency, but when this

CURVES OF CURRENT IN COILS OF AN OSCILLATION TRANSFORMER FOR A NON-QUENCHING GAP

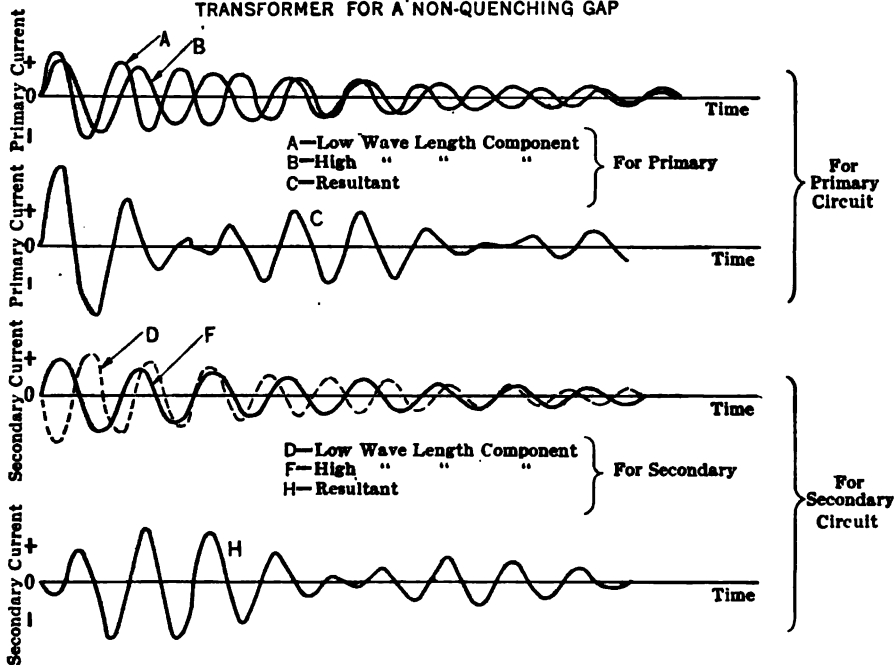

FIG. 37.—Currents in the two circuits of Fig. 35, high damping assumed.

is the case the secondary current is generally low. On the other hand, when the coupling is very close, although the current in the antenna is large, yet since it is made up of two component currents of two widely different frequencies the antenna will radiate energy at these two different frequencies; this is very objectionable because the total available energy is subdivided, and hence the range of transmission diminished, and also because it would interfere with other stations. As a matter of fact, the law in the United States requires that the energy of no other frequency shall exceed 10 per cent of that of the frequency on which the station is transmitting.

As outlined above, we find that when an open spark gap is used, which remains closed for some time after its breaking down and thus permits a current to be maintained in the closed circuit, we are confronted by either one of two evils, i. e., *low current* in antenna at a single frequency for loose coupling, and large antenna current of *two frequencies* for close coupling; besides, for both loose and close coupling, energy is wasted in the primary, since the latter has a current flowing in it for a longer time than necessary, which produces unnecessary losses, and subtracts from the energy which might otherwise be given to the antenna.

In order to overcome these difficulties advantage is taken of the fact that, as has already been pointed out, and as shown in Fig. 37, the primary and secondary currents (for close coupling and an open spark

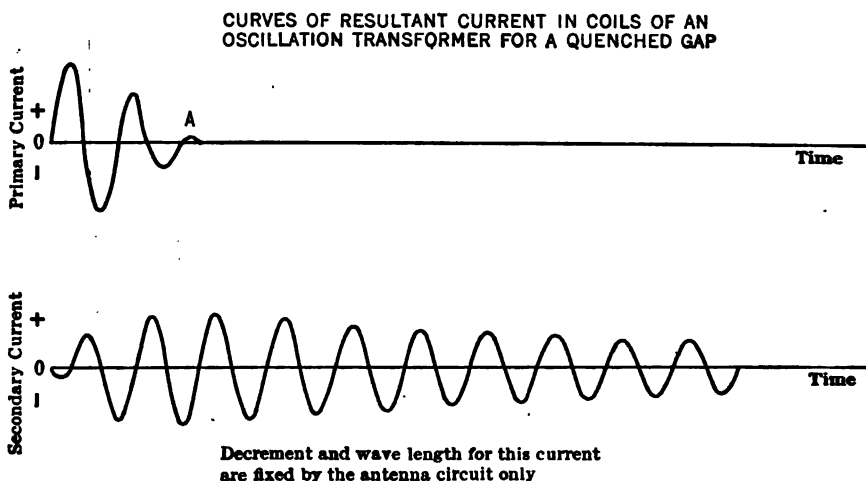

FIG. 38.—Currents in the two circuits of Fig. 35 if the gap used in the closed circuit is of the quenching type.

gap) pass through beat cycles, and that the amplitude of the primary current has minimum values at the same time that the amplitude of the secondary current has maximum values. It is plain that if the primary current were automatically interrupted when passing through its minimum amplitude values, the secondary circuit would then go on oscillating at its own frequency and damping. This, of course, would be made possible by the fact that the primary current would be interrupted when the secondary current amplitude values are a maximum and hence when almost the entire energy is in the secondary. According to this plan the current would be interrupted in the primary at the completion of the first one-quarter of a "beat-cycle" as shown at *A* in Fig. 38. To interrupt the primary current several methods may be used, the simplest of which is by replacing the ordinary open gap

by the so-called "quenched gap." The construction of this already has been described on page 316. Its characteristic is that it "opens" when the current in the primary of the oscillation transformer passes through its low values, probably because the comparatively few ions, which are formed between the sparking surfaces during the time of low current amplitude, recombine very quickly, thus making it impossible to maintain low currents through the gas between the sparking surfaces. Such a gap is said to "quench" the spark formed upon the discharge of the condenser. A quench gap may be and is generally operated with a close coupling of the oscillation transformer, because the closer the coupling the greater the amount of energy transferred to the antenna circuit; but if the coupling should be made extremely close then it is possible that the gap may refuse to quench, because of the very short time during which the closed circuit has its low amplitude current; this may not be sufficient to permit the gap to quench. A critical coupling, therefore, exists at which the gap quenches best; this coupling is quite close and far closer than could be used with an ordinary open gap; the secondary current as indicated by an ammeter, is a maximum for the critical coupling. Of course if the gap is quenching properly the secondary current should have a frequency equal to its natural frequency, and, since no current flows in the primary, the efficiency is higher and the decrement lower than for the "open gap."

The adjustment of a transmitting set as regards the coupling of the closed and open circuits, the gap, and the tuning of the two circuits is best determined by obtaining the "energy distribution curve." Such a curve is obtained in the following manner: a search coil of one or two turns is introduced in the antenna circuit as shown at *S*, Fig. 39, and a wave-meter circuit, consisting of L_4 , C_4 and a hot-wire meter *A* is loosely coupled to *S*. With the transmitter in operation the capacity C_4 is set at different values, and the reading of *A* is obtained; thus, as the natural wave-length of the circuit of $C_4 - L_4 - A$ is varied, the ammeter reading varies.

A curve plotted with values of the natural wave-lengths of circuit $C_4 - L_4 - A$ against squares of ammeter readings is known as "energy-distribution curve," and shows the relative amounts of energy radiated by the antenna at each wave-length. Another way to look at it is that, since the circuit $C_4 - L_4 - A$ is nothing but a receiving circuit loosely coupled to the transmitting antenna, it follows that the energy distribution

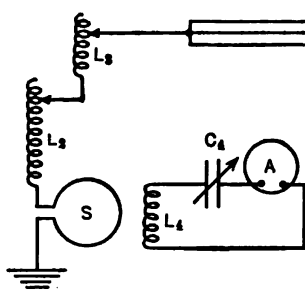

FIG. 39.—Use of wave-meter for getting wave-length of antenna circuit.

curve also represents the energy reaching the receiving circuit when it is adjusted to different natural wave-lengths. Whichever way one chooses to look upon the "energy distribution curve," it is plain that it is of great importance in the study and adjustment of a transmitting set. Two typical sets of such curves are given in Figs. 40 and 41 and a study of these will bear out some of the points brought out in the previous discussion. In these curves the ordinates represent squares of currents, and they were in one case read on a so-called "Wattmeter"¹ and in the other on a thermo-galvanometer.

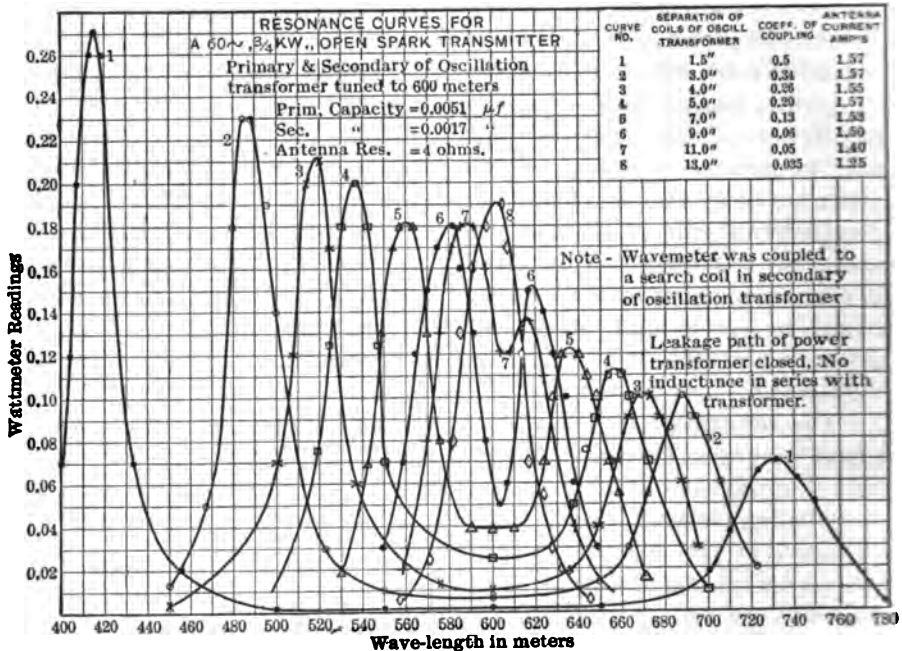

FIG. 40.—A set of resonance curves for a spark transmitter having a non-quenching gap; even when the coupling is as low as 5 per cent two distinct waves are emitted from the antenna.

Fig. 40 shows curves for an open gap and for different amounts of coupling, curve (1) being for the closest and curve (8) for the loosest coupling. It will be seen that for any but the loosest coupling there are two maxima in the radiation of the antenna at two different wave-lengths more or less separated from each other; thus, for curve 1, the two wave-lengths are 732 and 415 meters, while for curve 7 they are 616 and 588 meters. On the other hand, for curve 8 maximum energy is radiated at

¹ Wattmeter is the name often given, in radio measurements, to a hot-wire ammeter the scale of which is calibrated to indicate the power expended in the resistance of the instrument itself.

the one wave-length of 602 meters, i.e., the natural wave-length of the closed and open circuits. Again, by referring to the table inserted in Fig. 40 we note that the antenna current was a minimum for curve (8) (1.25 amperes) and a maximum for curve (1) (1.57 amperes). Or, as already pointed out, the loose coupling produces an antenna current which, though smaller than for close coupling, radiates maximum energy at a single frequency or wave-length.

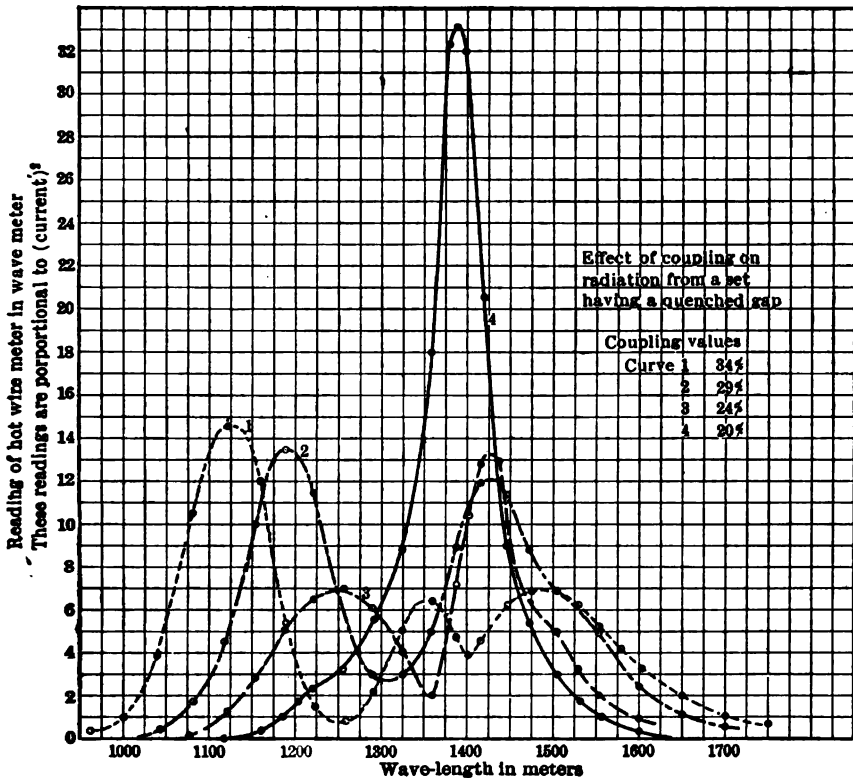

FIG. 41.—Resonance curves of a spark transmitter using a quenching gap; the gap would not properly quench if the coupling exceeded 20 per cent. For curves 1, 2 and 3 partial quenching is indicated by the presence of three “humps” on the resonance curve.

In Fig. 41 are shown some energy distribution curves for a set having a quenched gap, the values of coupling used being noted on the curve sheet. It will be seen that the radiation for any but the weakest coupling was impure, i.e., took place at more than one frequency. As the coupling is increased, in a quenched gap transmitting set, from very low values the antenna current, as read on the ammeter, will increase with the increasing coupling; for a certain coupling the antenna current reaches a maxi-

imum and then decreases sharply for a further small increase in coupling. The value of coupling just less than that at which the antenna current decreases is the proper one to use; it is the maximum value which can be used and still maintain the quenching action of the set.

Adjusting the Spark Transmitter.—In adjusting the transmitter shown in Fig. 1, to radiate at a certain wave-length and energy output, the following schedule of procedure should be followed. (Fig. 1 is reproduced here as Fig. 42 for convenience in following the directions given.)

1. With the antenna circuit open, the closed oscillating circuit is adjusted to the wave-length desired, by varying the value of inductance L_1 .¹ The primary capacity is usually fixed in value and is not readily changed, whereas the inductance L_1 , forming also the primary of the oscillation transformer, is always of the variable type, its construction being as previously described (page 320). The wave-length at which

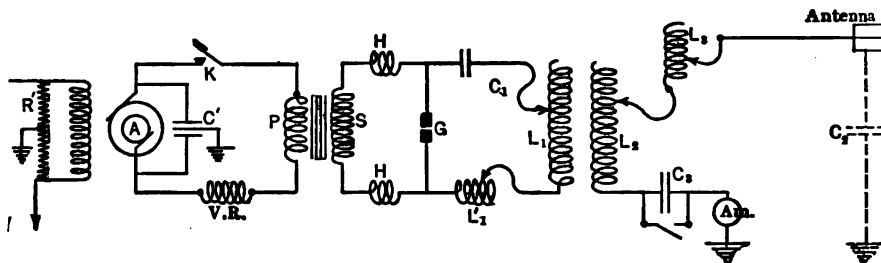

FIG. 42.—Spark transmitter circuit.

the circuit will oscillate may be marked on the inductance L_1 , different values of L_1 corresponding to different wave lengths, since C_1 is fixed and

$$\lambda_{\text{meters}} = 1885\sqrt{L_1 C_1},$$

L_1 and C_1 being given in micro-units.

This calibration is usually made by the manufacturer before the set is delivered. In certain emergency or special conditions, however, this may not have been done, in which case a wave-meter is loosely coupled to L_1 , and L_1 adjusted, until the wave-meter indicates a maximum deflection for the wave-length, at which the set is to transmit.

The student is referred to Chapter X for a detailed treatment of the wave-meter. For the present discussion it will suffice to say that it is simply a calibrated oscillating circuit, the wave-length of which is known for any and every position of a variable condenser element, the other element consisting of a fixed inductance. An indicating device, e.g., hot-

¹ In the discussion L_1 stands for the total inductance in the closed oscillating circuit, i.e., the sum of the inductances of L_1 and L'_1 of the diagram; as previously noted, the extra inductance in the closed oscillating circuit, L'_1 , is very seldom used.

wire ammeter, completes the instrument, the connections of which are shown in Fig. 43.

The ammeter deflection is a maximum, when the wave-meter circuit is in tune or in resonance with the closed circuit of the transmitter. Since L is constant, and $\lambda = 1885\sqrt{LC} = K\sqrt{LC}$, we have $\lambda = K'\sqrt{C}$, and the condenser scale may be calibrated directly in wave-lengths. When the ammeter reading is a maximum, the wave-length of the set is the same as the wave-length of the wave-meter, and is thus readily obtained from the calibrated condenser scale.

2. After the closed circuit has been adjusted to the desired wave-length, the antenna circuit is closed and *loosely* coupled to the closed circuit. The antenna inductance L_2 (or L_3 if in circuit) is then varied until maximum current is indicated on the antenna ammeter, under which condition the two circuits are in resonance. This adjustment may be checked, by coupling the wave-meter loosely to the loading coil, if in circuit, and noting the wave-length at which maximum deflection of the wave-meter ammeter is obtained. This should be the same as the wave-length for which the closed circuit was adjusted. It is important to note, that the wave-meter should not be coupled to the oscillation transformer secondary when making this check, but to some coil remote from L_2 . If no loading coil is used, a small search coil, consisting of a turn or two of wire, should be inserted in the circuit, remote from the oscillation transformer, and the wave-meter coupled to this coil.

This procedure is required because of the relations of the flux, which surrounds both windings of the oscillation transformer, when both windings are carrying current, and under which condition, double-frequency current flows in each circuit. It was shown (see page 231) that the lower-frequency currents in each winding are practically in phase, while the higher-frequency currents are practically 180° out of phase. The flux relations of the oscillation transformer, assuming a flat spiral construction, are thus as illustrated in Fig. 44.

It is apparent that a wave-meter placed between the two coils, as indicated in Fig. 44, will indicate resonance at the higher-frequency value, while if placed in the axial position will show resonance at the lower-frequency value. Intermediate positions will result in a combination of effects of the two fluxes, and the indications would therefore be inaccurate and confusing. It is thus always advisable to couple the wave-meter to a single remote coil in the antenna circuit. The disturbing effects of the oscillation transformer fluxes in the wave-meter indication,

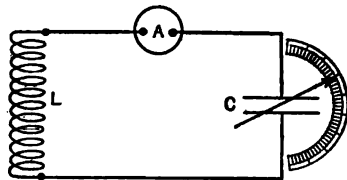

FIG. 43.—Simple wave meter circuit.

exist to some extent even with loose coupling and both circuits correctly tuned. However, a wave-meter coupled to the loading coil or search coil would give true indications under any condition. When the antenna is

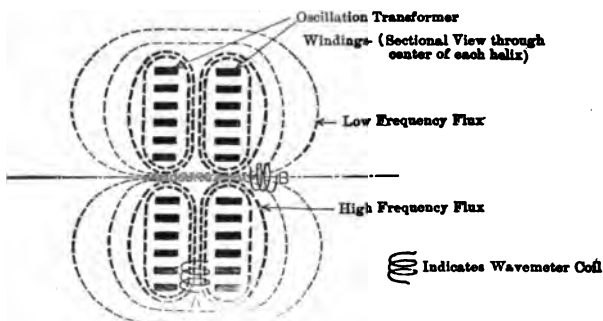

Fig. 44.—Cross-section through an oscillation transformer showing the distribution of flux due to the high- and low-frequency currents. With wave-meter coil on the axis low-frequency resonance is obtained, whereas with coil between the two parts of the transformer high-frequency resonance is obtained.

carrying much current, no search coil at all is required; if the coil of the wave-meter is placed near the earth lead sufficient coupling will be obtained.

It is interesting to note the variation of antenna current when L_2 or L_3 is varied. Fig 45A indicates the characteristics obtained when L_3

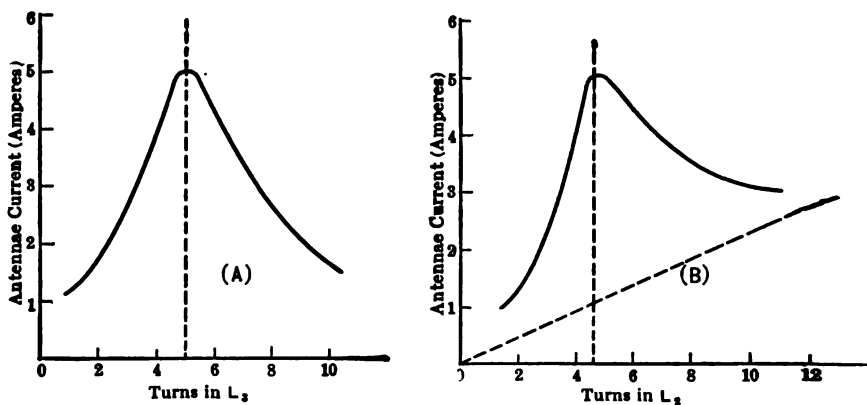

Fig. 45.—Tuning the antenna to the closed circuit by coil L_2 will give a different form of resonance curve than that obtained by varying L_3 .

alone is varied, while Fig. 45B indicates the results obtained when L_2 only is varied.

The difference is due to the fact that in Fig. 45A, the e.m.f. induced in the antenna circuit is not varied, but remains constant. Thus, as the resonant condition is reached, the current becomes a maximum, and

therefore decreases nearly symmetrically, as the turns in L_3 are continually increased. In Fig. 45B, however, the induced e.m.f. is not of constant value, but will increase as the turns increase, somewhat in the manner indicated by the dotted line. The current curve is thus unsymmetrical, but will have the same kind of symmetry as the curve of Fig. 45A if proper regard is had to the change in induced voltage.

3. The set, after adjustment of the closed and open circuits as outlined above, is in condition for sending at the given wave-length. The coupling should then be adjusted so that the energy radiated at this wave-length will be a maximum. This will not be at the highest value of coupling obtainable, nor will the antenna current be a maximum necessarily for this condition. Maximum antenna current indicates a maximum energy radiation, but the distribution of this energy, as discussed on page 326, is of more importance than the total radiation, and if the coupling is too close, the radiated energy may be distributed over a large range of wave-lengths. Thus the efficiency of the set, as measured by the energy reaching the receiving station, which is tuned to the wave-length for which the transmitter is adjusted, may be very much reduced. This is a very important point and one often overlooked; namely, that the criterion for best operation, is *maximum energy radiation at the wave-length for which the set is adjusted and not maximum antenna current.*

Characteristics of the Spark Transmitter—Energy Distribution Curves.—The energy distribution curves of a transmitter under different coupling values are shown in Fig. 46. The manner in which these curves are determined is described in detail in Chapter X, page 798. Briefly stated, a wave meter is loosely coupled to the antenna, remote from the oscillation transformer, and the deflections of the hot-wire ammeter (I^2) noted as the variable condenser, is adjusted to the different values of wave-length. The energy received by the wave-meter is proportional to the deflection of the hot-wire meter (if a hot-wire *ampere* meter is used as is generally the case) which is thus indicative of the energy radiated by the transmitter at the corresponding wave-length. The curve plotted from the data thus obtained is called the "energy distribution" curve and is of the greatest importance in determining the characteristics and action of the transmitter.

The form of the energy distribution curve will be determined by the coupling used, which in turn will be dependent on the following factors:

First.—The total amount of energy to be radiated. If the receiving station is at a considerable distance, more energy will be required and vice versa. This, however, is a minor factor, as the energy control is primarily obtained by spark gap adjustment.

Second.—The desired distribution of the energy radiated over the different wave-lengths as illustrated by the curves (Fig. 46).

Under certain conditions, as, for instance, the sending out of distress signals, etc., a broad distribution of the energy radiated is of prime importance and close coupling would be used. A large number of stations, all of which may be tuned to different wave-lengths, would thus be reached. This condition is shown by curve *C-C*, Fig. 46.

Under normal operating conditions, however, the distribution of the radiated energy is of greater importance, and the coupling is adjusted so as to cause a minimum of interference with other stations, within range, for whom the message is not intended. Under this condition the maximum energy is radiated at the wave-length for which the receiving set is tuned

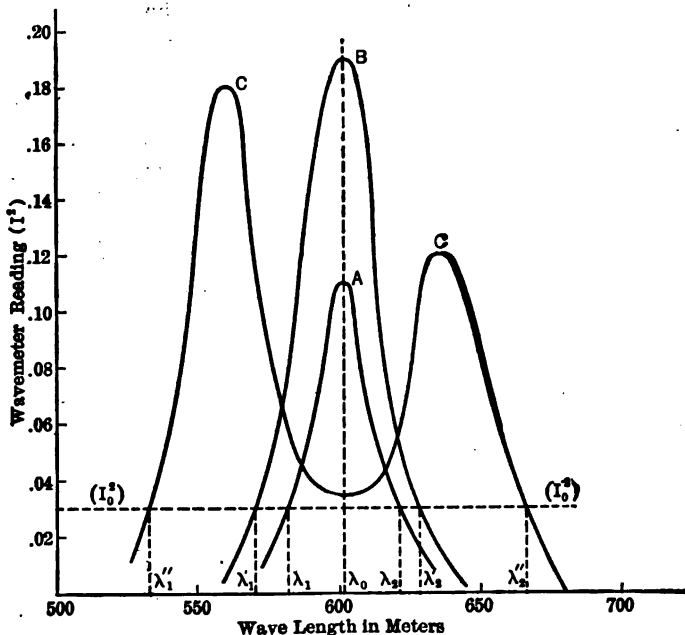

FIG. 46.—Energy distribution curve of a spark transmitter for three degrees of coupling.

(as indicated by curve *B*) and thus a maximum strength of signal would be obtained at the receiving station, although the coupling used would probably be considerably less than that used in curve *C*.

Adjustment of Power Input to the Transmitter.—The above description has considered the adjustment of the set for desired power output conditions. Power input adjustments will now be considered.

Since the high-frequency power input is equal to $\frac{1}{2}C_1E^2N$, this power may be controlled by varying the quantities C_1 , E , and N .

Normally, the group frequency (N) will not be varied, as the operating efficiency of the set will probably be considerably decreased for speeds other than noted. Also, as mentioned previously, the characteristics of the phones at the receiving station are usually such as to make

them most sensitive to a group frequency of about 1000 cycles per second, and it is therefore undesirable to deviate from this value to any considerable extent.

In practical installations, the closed-circuit capacity (C_1) is usually fixed in value, and could not be varied to secure a change in the power input.

The voltage to which C_1 is charged, E , is readily controlled, however, by adjusting the separation of the spark gap in the proper manner. This, therefore, forms the means whereby the power input may be controlled, and although limited in range, as discussed below, is widely used in practice.

In case a quenched gap is used the power input is controlled by using the proper number of gaps in series, many for high power and perhaps only one or two for short-range sending. It must be remembered that as the gap length is changed, or the number of sections of a quenched gap varied, the voltage of the alternator must be correspondingly altered to prevent arcing and irregular discharges.

Care of a Spark Gap.¹—As previously mentioned, the power input to the closed circuit condenser is immediately decreased if arcing occurs across the spark gap. To prevent this condition it is essential that the gap faces be clean and smooth. The electrode faces should therefore be periodically cleaned and polished with sandpaper or emery cloth, the necessity and frequency of this cleaning being determined by the time which the gap is in service. The alignment and separation of the electrodes must also be very carefully adjusted, if the maximum efficiency of the set is to be obtained and a pure note radiated.

If this is neglected one or more partial discharges may occur per alternation, and a constant group frequency will not be obtained, nor will successive trains possess equal energy. The action is similar to that of the non-synchronous rotary gap, but the group frequency may be more erratic, since it depends on the complex arc conditions existing in the gap, whereas in the former, the group frequency is partially controlled and fixed by the rotating element. These partial discharges, which may occur considerably below the peak value of the charging potential and at indefinite intervals, produce a non-musical note in the phones at the receiving station, which varies in intensity and pitch, and is disagreeable and fatiguing to the operator. It is also more difficult to hear the signal through interference than if the transmitter gap were properly adjusted and energy radiated at a single-group frequency. The above refers also to the synchronous rotary gap and quench gap if the separation of the electrodes is too small.

¹ The following remarks apply only to open gaps—A quenched gap should never be opened for inspection until it actually fails (by short-circuiting) as can be detected by seeing how long a spark will jump across the gap section outside.

Improper adjustment of the gap (except the quenched type) is readily detected by observing the character of the spark. If the separation is too small, the discharge will be yellowish in color and emit a roaring sound, which is characteristic of the arc, whereas under proper conditions, the discharge is white, with a snappy crackling sound.

Too great a separation of the electrodes results in uncertain operation due to the gap not breaking down regularly once every alternation, but every other alternation or once every third or fourth alternation perhaps; that is, there occurs a resonant rise of voltage with corresponding energy storage before the breakdown voltage value is reached. (See Figs. 21 and 22, pp. 307, 308.) The condenser and step-up transformer may be severely stressed under these conditions and their failure may occur unless designed specifically for these operating conditions. A hot-wire ammeter, suitably insulated, and inserted in the closed circuit, forms an effective aid in securing proper adjustment of the gap, for the high-frequency power (and current) in the closed circuit is then a maximum, as shown by the ammeter indication.

Proper Motor Speed.—The proper motor speed will evidently depend on the rated frequency of the connected alternator and the pairs of poles, since

$$f = \frac{p \times \text{r.p.m.}}{60} \quad (\text{in cycles per second})$$

$$\text{r.p.m.} = \frac{60 \times f}{p}$$

Thus, assuming a 500-cycle alternator with 20 pairs of poles, we have,

$$\text{r.p.m.} = \frac{60 \times 500}{20} = 1500 \text{ r.p.m.}$$

as the motor speed.

The speed of the driving motor must be strictly constant if a musical note of constant pitch is to be heard in the phones at the receiving station, and as previously mentioned, the modern shunt-wound or differentially wound motor satisfactorily fulfills this requirement. It is evident that by suitably adjusting the driving motor speed (by means of the motor field rheostat) a limited control of the group frequency of the set is possible. Thus by driving the above alternator at 1200 r.p.m., the group frequency may be made 800 instead of 1000. Similarly 1800 r.p.m. will give a group frequency of 1200. There is no particular advantage in this, however, as the telephones usually have maximum sensitivity for a group frequency of about 1000 cycles per second, and the operation of the spark gap will be erratic at other than rated frequency, as explained on page 308.

Capacity and Inductance of the Closed and Open Circuits.—The proper capacity to be connected into the closed circuit will depend on the amount

of the high-frequency power which it is intended to generate, the charging voltage to be employed, and the group frequency, since

$$W_{\text{watts}} = \frac{1}{2} C_1 E^2 N,$$

when

C_1 = closed circuit capacity in farads;

E = potential in volts to which condenser is charged;

N = group frequency in wave-trains per second.

Thus, if we assume

$$W = 2\frac{1}{2} \text{kw.} = 2500 \text{ watts};$$

$$E = 15,000 \text{ volts};$$

$$N = 1000 \text{ (alternator frequency} = 500)$$

we have,

$$2500 = \frac{1}{2} \times C_1 (1.5 \times 10^4)^2 \times 1000$$

$$C_1 = .022 \text{ microfarad.}$$

The closed-circuit inductance, which also acts as the primary of the oscillation transformer, will be determined by the above value of C_1 and the maximum wave length at which the set is expected to radiate,

Since: $\lambda_{\text{meters}} = 1885 \sqrt{L_1 C_1}.$

Where

L_1 = closed circuit inductance in microhenries;

C_1 = closed circuit capacity in microfarads,

we have, assuming $\lambda_{\text{max}} = 1000 \text{ meters}$

$$1000 = 1885 \sqrt{L_1 \times .022}$$

$$L_1 = 12.8 \text{ microhenries.}$$

For proper operation the open (antenna) circuit constants L_2 and C_2 must satisfy the relation

$$L_1 C_1 = L_2 C_2,$$

where L_1 and C_1 are the same as indicated above;

C_2 = total effective capacity of antenna circuit;

L_2 = total effective inductance of antenna circuit.

Usually, C_2 will be considerably less than C_1 due to the difficulty and expense of building large capacity antennæ and thus L_2 usually exceeds L_1 in value. If we assume an antenna capacity of .0024 microfarad,¹ then

$$L_2 = \frac{.022}{.0024} \times 12.8 = 117 \text{ microhenries.}$$

¹ Represents approximately an "L" antenna, length of top = 200 feet, height = 98 feet, number of wires = 6.

All of this inductance would not be contained in the secondary winding of the oscillation transformer, a large part of it would be supplied by the loading inductance, while a relatively small portion would be found in the antenna itself. In the antenna referred to above, the inductance would be, perhaps, 20 microhenries.

Thus, the closed and open circuits are tuned to the same wave-length, and if the coupling between them has been properly adjusted (see above), a maximum amount of energy will be radiated at 1000 meters and the efficiency of operation will be a maximum for the given conditions. The procedure to be followed in adjusting for a different wave-length or changing the energy radiated by the set has already been described.

Elements of the Receiving Station—Visual Detection.—The general connections and action of a receiving set have already been discussed (see page 190). Primarily, it constitutes a circuit which absorbs a portion of the electrostatic and electromagnetic energy which reaches it from the transmitter, combined with certain devices to make this absorbed energy produce maximum visible or audible effects, so that its reception may be evidenced and intelligence thus transmitted.

The antenna circuit represents the energy absorbing element of the receiving set. The waves of electromagnetic and electrostatic energy sent out by the transmitter, induce an e.m.f. in the antenna circuit, the natural frequency of which is the same as that of the transmitter. If the antenna were connected directly to ground as indicated in Fig. 47A, the circuit would be complete and a current would be caused to flow as long as energy is radiated by the transmitter. If a sensitive hot-wire ammeter were inserted as shown, then this energy reception would be made visible, and thus a message might be transmitted between the two stations, if the radiated energy is interrupted in accordance with a prearranged code.

This arrangement represents the simplest possible form of receiver, but is never used, due to the impracticability of the sensitive ammeter which would be required. The antenna would probably not be tuned to the frequency of the e.m.f. induced in it, and the resultant current would be extremely small, requiring a very sensitive instrument for its detection.

It is obvious that this current could be materially increased by so adjusting this circuit that its natural frequency is made the same as the frequency of the e.m.f. induced in it, i.e., the radio frequency of the received signal. This would be most easily accomplished by inserting a variable inductance in the circuit, provided the natural frequency of the antenna is above that of the incoming energy. (A variable condenser would be inserted if the received energy has a frequency above that of the antenna.) However, the current is very small even with the circuit adjusted to resonance, and the hot-wire ammeter would of necessity be of a very deli-

cate construction, making it impractical to use. Such, an instrument would possess considerable resistance, which would still further limit the current flowing when the circuit is adjusted to resonance. In addition, its indications are inherently sluggish, and would require such a slow speed in sending, as to make its application for receiving purposes completely impractical. The addition of a variable inductance or capacity for tuning the antenna circuit is indicated in Fig. 47B.

Audible Detection.—In place of the above scheme of detection, which may be termed the visual method, a detector is used which causes the incoming energy to produce audible effects. Thus we might substitute a telephone receiver in the antenna circuit in place of the ammeter. The receiver is described in detail below. (See page 341.) Briefly, it consists of a soft iron diaphragm actuated by current flowing through a winding placed on a permanent "U" magnet, the poles of which are placed closely

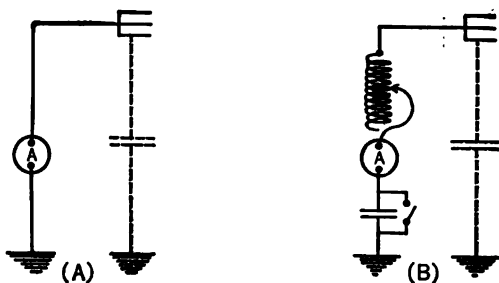

FIG. 47—Simple schemes for receiving radio signals.

adjacent to the diaphragm. An alternation of current of a certain polarity thus increases the pull on the diaphragm, whereas the reverse alternation will decrease the pull. The diaphragm is thus moved inward and outward, setting up vibrations in the air which are heard as sound by the observer.

The placing of such a receiver in the antenna circuit would, however, produce no sound in the phones even though high-frequency current were flowing in the antenna. This is due to the fact that the mechanical inertia of the diaphragm will not permit it to follow the extremely rapid reversals of the radio frequency current. This reversal would occur at the rate of 1,000,000 times per second for a 300-meter wave signal. Also, even though it were possible for the diaphragm to respond to this current, no sound would be heard, as the frequency would be far above the limit of audible frequencies (about 20,000 cycles). The conditions are indicated in the following curves (Fig. 48). The receiver would also add thousands of ohms impedance to the antenna circuit, so that only negligible high-frequency current could flow.

Application of the Rectifier.—If we place in the antenna circuit, in addition to the phones, some device possessing unilateral conductivity, that is, a greater resistance to current flow in one direction than in the other, we would obtain a net or cumulative effect for each wave-train, since the effect on the diaphragm in the one direction would then exceed the effect in the reverse direction. Thus the diaphragm would be given a resultant deflection, springing back to its initial position only after the wave-train had passed. Thus, if 1000 wave-trains strike the antenna per second (group frequency of transmitter=1000), the diaphragm would be impulsed 1000 times per second, and the observer would hear a 1000-cycle

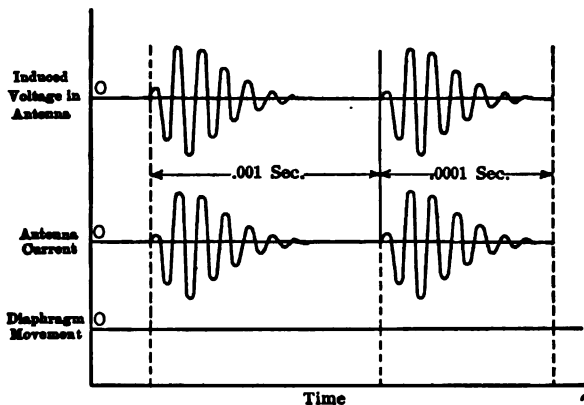

FIG. 48.—Conventional diagram of current in antenna of receiving station; even if such high-frequency currents could flow through the telephone the diaphragm could not move so rapidly.

note whenever the transmitter radiated energy. These conditions are graphically shown in Fig. 49. The amplitude variation of the e.m.f. for this figure should be carefully noted. The first cycle is of maximum amplitude in only one circuit of both sending and receiving stations, namely, the closed circuit of the transmitter. In all other circuits, time is required to build up the oscillations to their full amplitude, due to the electrical storage of energy which takes place during this period, just as in setting a mechanical system into oscillation, maximum amplitude is not obtained on the first impulse. (Unless the system starts with original distortion, as e.g., a pendulum held to one side and then released, which condition corresponds to that existing in the closed circuit of the transmitting set.)

The complete receiving circuit with the asymmetrical resistance, commonly known as a "detector," is indicated in Fig. 50. (The term "detector" is not strictly applicable, for it does not detect, but enables the receivers to detect, or make evident to the senses, the energy that is supplied to the telephone receivers.) Due to the high resistance of

the phones, and the asymmetrical character of the rectifier resistance this circuit is not selective, and it would be difficult to receive except under the unusual condition that only energy from the sending station desired

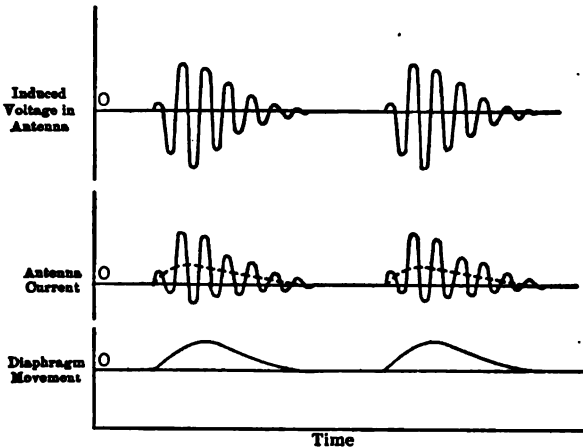

FIG. 49.—When a rectifier is used the antenna current is asymmetrical; more flowing in one direction than in the other; such a current will give the telephone diaphragm one impulse per wave-train.

is reaching the antenna. Also the magnitude of the current flowing even under the best conditions is very small. For these reasons it is desirable and advantageous to connect the detecting apparatus in a separate circuit coupled inductively to the antenna by means of coils L_1 , L_2 , Fig. 51, the two forming what is known as the receiving coupler.

Inductively Coupled Receiver.—With this connection, the primary or antenna circuit may be tuned accurately to the frequency of the incoming energy, and since all high resistances have been removed, the antenna current will attain a maximum value very much greater than possible with the preceding arrangements. Therefore the e.m.f. induced in the secondary and the resulting current flow will be maximum and the signal strongest, although it will still be relatively weak due to the high resistances in the second circuit, which diminishes the resultant current. This circuit possesses some selectivity due to the adjustment of natural frequency possible in the low resistance antenna circuit. To enable the circuit to be tuned over wide ranges of wave-length, and additional inductance L' , known as a "loading" inductance, is inserted as shown for very long wave-

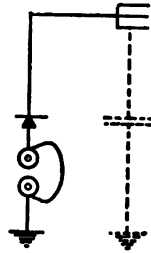

FIG. 50.—A possible scheme for using telephone and rectifying crystal.

lengths, while the condenser C_1 may be cut into circuit if it becomes necessary to tune for very short wave-lengths. This condenser is therefore known as a "shortening" or "short-wave" condenser.

To increase the selectivity and sensitivity of the set, a tuning condenser C_2 is placed across the coil L_2 , giving the final circuit illustrated in Fig. 52, which represents the arrangement most generally used.

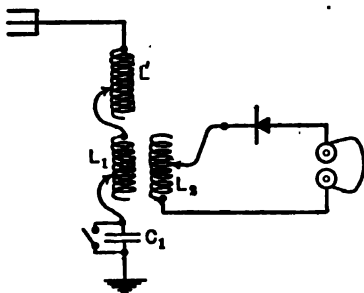

FIG. 51.—A receiving scheme using two circuits, the secondary being untuned.

adjusting C_2 . Since the e.m.f. set up in the circuit L_2C_2 increases with the number of turns in L_2 , it is desirable to have this inductance as high as possible without, however, making the coupling so close as to diminish seriously the selectivity of the set. Similarly, the condenser required for any wave-length adjustment should be relatively small. Under these conditions the radio-frequency voltage across the terminals of L_2 and C_2 (for a given amount of received energy) will be a maximum, and this radio frequency voltage will, in turn, cause a maximum unsymmetrical current to flow in the detector-telephone circuit, and therefore maximum signal strength will be obtained. The action of the phones and detector on this connection is exactly similar to their action in the circuit illustrated in Fig. 49.

If the resistances involved in the primary and secondary circuits of the set are small, then this receiving circuit possesses considerable selectivity. Undesired signals may be tuned out and the efficiency and operating characteristics of the set are very much better than those of the previous circuits discussed.

The Telephone Receiver.—The construction of the telephone receiver usually employed for the reception of radio signals, known

Neglecting for the moment the detector and phones connected in shunt across the condenser, it is readily seen that we may tune the secondary circuit to resonance with the primary circuit, and thus secure a maximum current flow in the circuit L_2C_2 . L_2 is generally used for rough tuning, while a finer adjustment may be secured by

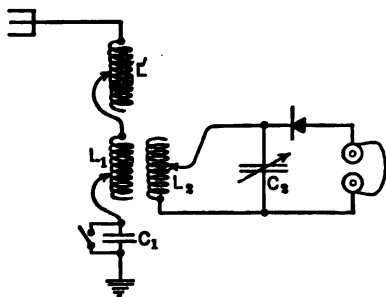

FIG. 52.—The ordinary receiving circuit using two tuned circuits, telephone in series with rectifier being shunted across the tuning condenser of the secondary circuit.

as the "watch-case" type, is shown in the accompanying sketch. (Fig. 53.)

It consists essentially, of a permanent magnet *M*, with pole pieces *N* and *S*, upon which are wound coils consisting of many turns of fine wire, through which the audio frequency pulses of current pass. A diaphragm *D* is placed closely adjacent to the faces of the pole pieces as shown. When no signal is being received, this diaphragm is under a constant pull or attraction exerted on it by the permanent magnet *M*.

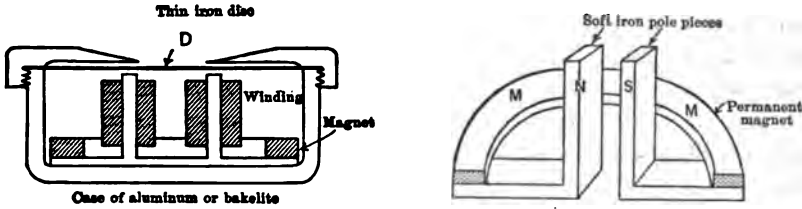

FIG. 53.—Essential elements of the ordinary watch-case telephone receiver.

This steady pull, which we may call *P*, is proportional to the square of the flux flowing through it and the permanent magnet, i.e.,

$$P = K\phi_s^2, \dots \dots \dots (9)$$

where ϕ_s is the steady flux value.

When a current of proper polarity flows through the winding, the flux will be increased proportionately (neglecting saturation effects) or

$$\Delta\phi = K'i, \dots \dots \dots (10)$$

wherein *i* represents current in the winding.

Therefore the total flux is:

$$\begin{aligned} \phi_t &= \phi_s + \Delta\phi \\ &= \phi_s + K'i, \dots \dots \dots (11) \end{aligned}$$

and the total pull under this condition becomes

$$\begin{aligned} P &= K\phi_t^2 = K(\phi_s + K'i)^2 \\ &= K\phi_s^2 + 2KK'\phi_s i + KK'^2i^2. \dots \dots (12) \end{aligned}$$

The total pull thus consists of three components, one of which is constant ($K\phi_s^2$) and thus has no effect on the diaphragm vibrational amplitude, while another is proportional to the current variation squared (KK'^2i^2). This term represents a distortional component of double fre-

quency and it is therefore designedly made relatively small. The remaining component of pull is proportional to the current variation ($2KK'\phi_s i$) and this component is therefore made as large as possible, as the amplitude of the diaphragm vibrations will then be proportional to the amplitude of the current variation (i); it will also be directly proportional to the flux due to the permanent magnet, (ϕ_s). Thus, to make the vibrations of the diaphragm a maximum for a given current variation, $K\phi_s$ is designedly made large compared to $KK'i$, which means that the flux (ϕ_s) produced by the permanent magnet is much greater than the flux produced by the current in the winding ($\Delta\phi$). Under these conditions, distortional effects are minimized and maximum amplitude of diaphragm vibration and signal strength (sound) for a given signal current (i) secured.

The d.c. resistance of a receiver such as described above would be about 2000 ohms, as many as 10,000 or more turns of fine wire (about No. 40 A. W. G. or smaller) being employed to make up the winding. The impedance to an alternating current will, of course, be greater than this, depending on the frequency of the current and the effective resistance of the circuit. At 400 cycles a certain receiver of this type had an impedance of 2900 ohms; at 800 cycles an impedance of 3900 ohms, and at 1000 cycles an impedance of 4400 ohms.

The Baldwin Receiver.—Another type of receiver more recently developed, known as the Baldwin receiver, possesses the advantage that

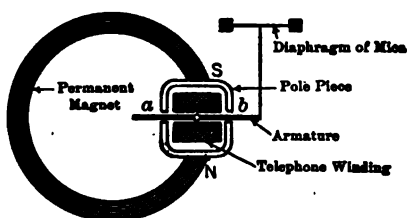

FIG. 54—Essential elements of the Baldwin balanced-armature telephone receiver.

the diaphragm is not initially stressed, and thus may be more responsive and sensitive to the pull exerted on it by the flux ($\Delta\phi$) caused by the signal current (i). The construction is indicated below (Fig. 54).

It is evident that when no signal is being received, the armature being balanced in its neutral position (the flux traversing the gaps a and b in the same direction and being equal in value) no pull is exerted on the mica diaphragm. If a signal pulsation of current passes through the receiver winding, however, it produces a flux, which, combining with the permanent flux, results in an asymmetrical distribution of the flux, causing a force to be exerted on the armature and thus on the diaphragm.¹

Other advantages claimed for this type of receiver in addition to the one mentioned above, are:

¹ The student is referred to E. I. Bucher, "Practical Wireless Telegraphy," page 168, for more detailed description.

(1) The magnetic circuit is of low reluctances and thus small signal currents will produce relatively greater fluxes and greater forces.

(2) The armature is similar in its mounting to a lever, with a force acting at each end. The diaphragm, being rigidly attached to one end, thus has an increased deflection for a given magnetizing force, and thus the signal strength is intensified.

It is to be noted that this device is not truly balanced (when no signal is being received) in the case of detectors where the initial current is not zero, as in the vacuum tube and crystal equipped with polarizing battery. The pull due to this current, however, is extremely light, compared to the heavy pull exerted by the permanent magnet in the usual type of construction, and the diaphragm may be considered as essentially unstressed.

Characteristics of Crystal Rectifiers.—From the previously mentioned function of the rectifier as utilized in the reception of radio signals, it will be seen that the essential characteristic which it must possess is that of unilateral conductivity. This means that the rectifier possesses a high conductivity for current of a given polarity, and relatively low conductivity for current of opposite polarity. Due to this property, a train of high-frequency e.m.f. waves impressed on the circuit containing the phones and detector (in series) will result in a net force being exerted on the diaphragm, the resultant deflection producing a click in the phones. With the detector omitted, the net effect is not obtained and no click results, the diaphragm being unable to follow the high-frequency current alternations due to its mechanical inertia. These effects have been previously indicated by the curves shown in Fig. 48 and 49.

The unilateral conductivity possessed by various crystals is shown by the following curves (Figs. 55 to 58, inclusive). These curves indicate the relatively large currents obtained when e.m.f. of various values and of a given polarity are impressed across the rectifier circuit and the comparatively small (practically negligible) currents obtained when the e.m.f.'s are reversed. These curves represent the "d.c. characteristic" of the crystals in contradistinction to the "a.c. characteristic" discussed below, and are obtained by means of the experimental circuit indicated in Fig. 60 (Insert A).

Fig. 55 illustrates the characteristics obtained for a carborundum (silicon carbide) crystal. The curve is interesting as it illustrates the function of the local battery, sometimes used in series with the detector and phones, and known as a "polarizing" battery. The connection of this battery in the detector circuit is illustrated below (Fig. 59).

It is evident that with any detector the greatest asymmetrical effect (and thus maximum signal strength) will be obtained, if we adjust the crystal to operate at the point of maximum change of curvature. In the

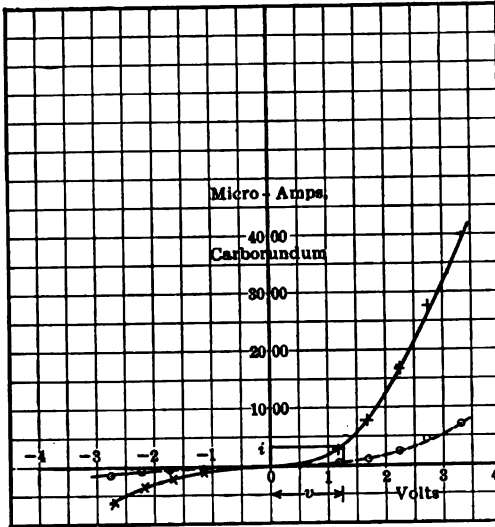

FIG. 55.—Characteristic curves of a carborundum rectifying crystal, using a fine steel point for making contact. The maximum rectifying action occurs when a polarizing voltage of about 1.2 volts is used.

this adjustment, the asymmetrical effect of the crystal is practically *nil*, and the resistance of a uniformly high value.

Fig. 56 illustrates the characteristics taken for a Cerusite crystal (trade designation), under conditions of good and poor adjustment. The asymmetrical conductivity obtained with the good rectifying point is more pronounced for this crystal than for the carborundum crystal of Fig. 55, and no polarizing battery would be required, as a sharp "break," or high rate of change of curvature, is obtained at zero voltage. The resistance is uniformly very high on the poor rectifying point, and is practically constant in value for all e.m.f. values.

case of the curve considered, this does not occur at the zero voltage value but at +1.25 volts approximately. Therefore the local battery potentiometer would be adjusted to impress an initial voltage of +1.25 volts on the crystal. Under these conditions the signal voltage impressed on the potentiometer, detector, and phones in series, would vary the current above and below the initial value (indicated by i in Fig. 55) and a maximum asymmetrical current thus secured.

The "d.c. characteristic" is also indicated on the figure for a poor rectifying point, which indicates that with

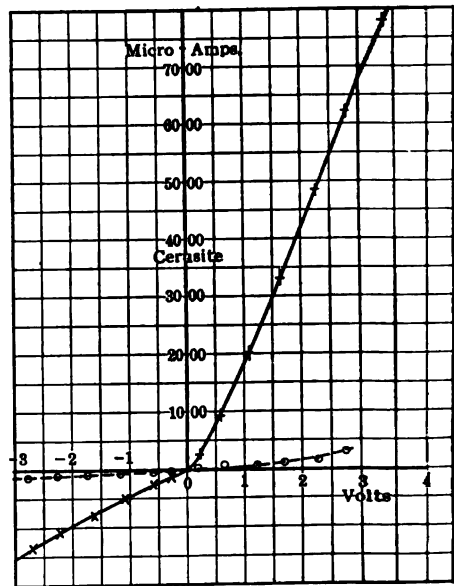

FIG. 56.—Characteristic curves of a "Cerusite" rectifying crystal.

Fig. 57 illustrates the d.c. characteristics for two different points on a detector known as a Lenzite crystal, which show the same general form as the corresponding curves in the previous figures. No polarizing battery would be required if the crystal is operated on the good rectifying point. The unilateral conductivity of the crystal is indicated to some extent even for the poor point, and some detection may be secured on this condition, if very strong signals are being received.

Fig. 58 illustrates characteristics obtained with a combination of two crystals, zincite (red oxide of zinc) and chalcopyrite (iron-copper sulphide), which differs from the preceding cases in which a sharp metallic point is placed in light contact with the crystal. The curves indicate that a polarizing e.m.f. may be desirable, and also show that considerable rectification will be secured even if operating on a poor point. This would make the combination desirable for use where adjustments may be frequent, due to vibrations

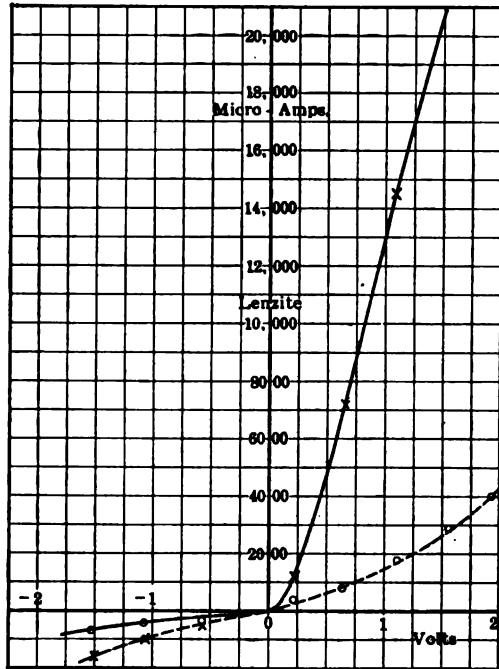

FIG. 57.—Characteristic curves of a "Lenzite" rectifying crystal.

or similar disturbances, which may be present, as in the case of portable receiving equipment and stations on shipboard.

The asymmetrical effect of the detectors described above, when an alternating potential is impressed across the circuit in which they are connected is indicated by the curves (using a zincite-chalcopyrite) shown in Fig. 60. The experimental circuit used is shown in Fig. 60 (Insert B). Both the d.c. and a.c. characteristics are indicated, the former being plotted between the d.c. voltage and corresponding current as heretofore, while the latter is plotted between the effective a.c. voltage and the d.c. component of the rectified alternating current, as read by the same d.c. ammeter used in obtaining the "d.c. characteristic." The instantaneous values of the current flowing in the detector circuit when a sine wave e.m.f. is impressed, have been plotted in Fig. 61, wherein the corresponding

voltage values are also indicated. It should be noticed that the negative alternations of the current are practically negligible in amplitude, while the positive alternations are not

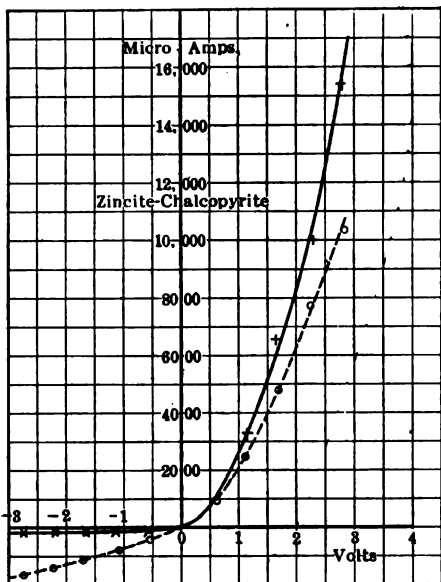

FIG. 58.—Characteristic curves of a "Perikon" rectifier, utilizing the contact between zincite and chalcopyrite.

from the a.c. test indicates the d.c. component plotted to various corresponding a.c. voltages as indicated by the curve in Fig. 60.

The insert curve in Fig. 60 illustrates the a.c. and d.c. characteristics to a magnified scale in the region of the zero voltage point. It is interesting and important to observe that this d.c. characteristic indicates satisfactory rectification, for very small voltage values, such as would exist across the detector-phone circuit under normal conditions, although the more extended curve (main curve of Fig. 60) would seem to indicate that for small voltage variations, a polarizing e.m.f. of about $+ .25$ volt would be desirable. These data demonstrate the fact that if the characteristic curves are to be considered reliable, and truly indicative of what the rectifier will do in its application to radio signal reception,

the positive alternations are not of sine-wave form but considerably more peaked, due to the variation in detector resistance, which decreases as the current increases.

This current may be graphically resolved into its d.c. and a.c. components as shown in the figure. The latter component will not affect the d.c. ammeter the deflection of which is proportional to the magnitude of the d.c. component only, the value of which it indicates. Thus, for an effective a.c. voltage of 1.41 volts Fig. 60 (maximum value equal to 2 volts as shown in Fig. 61) the reading of the ammeter is 2 milliamperes, which is the magnitude of the d.c. component as indicated in Fig. 61. Thus the curve obtained

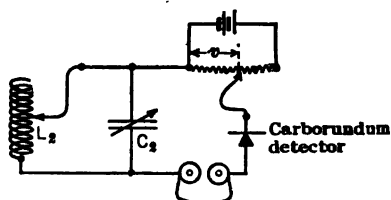

FIG. 59.—Scheme of using such a crystal as carborundum in a receiving circuit. The best rectifying action is obtained by suitable adjustment of the potentiometer on the polarizing battery.

it is desirable to investigate them for low values of impressed voltages and not carry them out to voltage values as large as 2 volts,

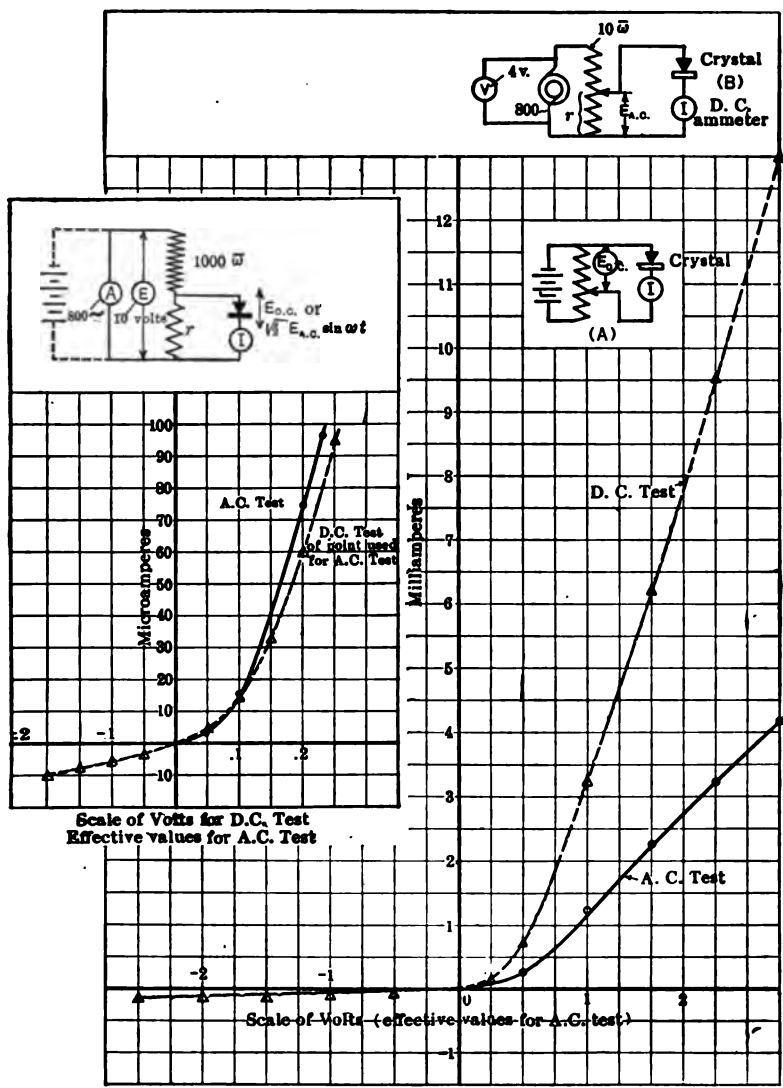

FIG. 60—Comparison of d.c. and a.c. characteristics of a Perikon detector. The a.c. characteristic was obtained by measuring the current through the rectifier with d.c. ammeter when an alternating e.m.f. was impressed. The insert shows the really important action, as it is seldom that more than a small fraction of a volt is set up across the rectifier when it is used in a receiving circuit.

a magnitude practically never encountered in normal radio reception.

Desirable Characteristics of Crystal Rectifiers.—Crystal detectors or rectifiers should possess the following qualities:

1. They should be mechanically rugged and well constructed. This means that they should be able to hold their adjustment and not be easily disturbed. These are especially desirable characteristics in field or marine sets, where jarring or vibration is likely to be present.

2. The crystals should be sensitive, that is, should possess good rectifying properties, if their setting is properly adjusted. Too great a sensibility is not desirable as satisfactory adjustment is usually obtained with difficulty. Also it may be difficult to retain the sensitive adjustment.

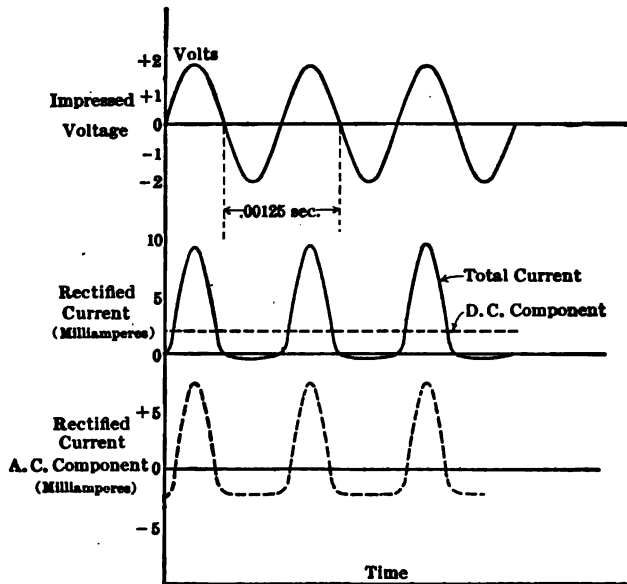

FIG. 61.—Analysis of the current through a rectifying crystal.

3. The crystal should be easily adjusted. It is a distinct disadvantage if any marked difficulty is found in adjusting the setting for good reception, as valuable time may be lost in this way if a signal is coming in and the detector not operating properly.

4. The crystal should possess self-protecting characteristics to prevent itself from being "burned out" and the setting destroyed, if abnormally powerful energy radiations are received, such as static and other atmospheric disturbances.

A complete explanation for the asymmetrical conductivity of two dissimilar crystals in contact, or a crystal in contact with a metal point has not yet been advanced. It may be due, in part, to the thermo-electric effects produced by the heating of the junction when the detector is

carrying current.¹ The rectifying properties have also been considered as being due to electrolytic action, which occurs at the surface of the crystal.² A more likely explanation, however, is based on the "surface work" for electron evaporation from the two crystals; if the "surface works" are different, the contact point must offer asymmetrical resistance.³

Application of the Bridging Condenser.—It will be recalled that the telephone receiver possesses considerable impedance for a 1000-cycle alternating current. It might seem that it would be impossible to send a radio frequency current through the phone circuit, and this would be the case were it not for the distributed capacity which is associated with the windings in the phone, and the phone cords. This capacity is in shunt with the telephone windings, and is represented by the fictitious condenser, C' , in Fig. 62.

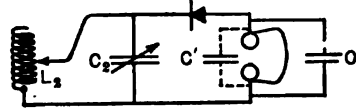

FIG. 62.—Use of a "bridging" condenser in parallel with receiver.

The current may then be considered to divide in the circuit as shown in Fig. 63, the radio frequency component passing through the distributed

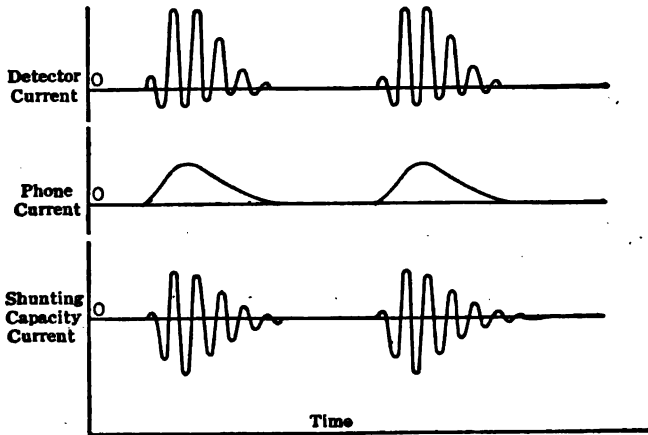

FIG. 63.—Currents in the branched circuit shown in Fig. 62.

capacity, which has a relatively low impedance to high-frequency current, while the audio frequency component flows through the phone windings.

Normally, however, the distributed capacity of the phone cords, etc., is only a few micro-microfarads in value and is not large enough to supply

¹ W. H. Eccles, Proc. Phys. Soc., London, Vol. 25, p. 273, June, 1913.

² R. H. Goddard, Physical Review, Vol. 34, 1912.

³ It is to be noted that any explanation must be able to take care of the fact that certain crystals rectify in one direction for low voltages, and in the opposite direction for higher voltages, not rectifying at all for some intermediate voltage.

a low impedance by-path for the high-frequency component. It is therefore usual to connect additional capacity across the phones, as shown in Fig. 62, condenser *C*. This additional capacity is known as a bridging condenser, and may have a value of approximately 5000 $\mu\mu f$. A low impedance path for the high-frequency component is thus supplied, thus permitting a larger fraction of the high-frequency signal voltage to act across the rectifying crystal and hence increasing its rectifying efficiency. This, in turn, increases the amplitude of the audio-frequency component flowing through the phones and the strength of the received signal is thereby increased.

The bridging condenser is sometimes considered as a capacity which receives a cumulative charge during the passage of a wave-train, due to the asymmetrical conductivity of the rectifier, comparatively little current passing through the phones. When the wave-train has passed this condenser discharges through the phones, since it cannot discharge back through the detector, due to high resistance in this circuit. This unidirectional discharge passes through the phone winding as a current pulse equivalent to the d.c. component previously described. Thus one click is produced in the phones per wave-train, and the observer hears a note of audio frequency pitch as previously described.

Vacuum Tube Detector.—The crystal rectifier is being rapidly superseded by the three-electrode vacuum tube due to the latter's greater sensitivity, reliability, and ease of adjustment. The action of the tube is discussed in detail in Chapter VI, to which the reader is referred for a full explanation of its rectifying action. One advantage of the tube over the crystal lies in the fact that its rectifying ability is measured by the accuracy of its design and construction, while that of the crystal is an inherent property of the substance, and cannot be altered or improved. With the latter, the "best" point of operation is determined experimentally and may or may not represent the best performance of which the crystal is capable. On the other hand, the tube may be accurately and definitely adjusted for best operation, which as already stated, exceeds that of the best crystal rectifiers. The more general use of the tube has been somewhat retarded by its higher first cost, and various patent situations involved in its manufacture and distribution.

With the ending of the war, however, the tube is being more and more extensively used and will probably be the only detector ultimately in use.

Adjustment of Receiving Set.—The receiving circuit for a spark set has already been studied on page 340, and it now remains to discuss the characteristics of such a circuit and the adjustments necessary to secure the best results. Before doing this, however, we must define two quantities, upon which the comparison of receiving systems is based, i.e.: "audibility" and "selectivity."

“Audibility” may be defined as the ratio of the audio current flowing through the telephone receivers to that which is necessary to make the signals just audible. To speak of a receiving circuit having an audibility of, say, 20, means that the current in the receiving circuit is twenty times that which is just necessary to produce a just audible signal.

The audibility thus defined is directly proportional to the current in the receiving antenna and, for weak couplings, say less than 5 per cent, inversely to the coupling coefficient between the receiving antenna circuit and the receiving closed circuit. Again for short distances the receiving antenna current may be shown to vary as follows:

$$I_r \propto \frac{I_s h_s h_r}{R \lambda d}, \dots \dots \dots (13)$$

where

I_r = receiving antenna current;

I_s = transmitting antenna current;

h_r and h_s = height of receiving and transmitting antenna, respectively;

R = effective resistance of the receiving antenna, including the resistance due to the closed circuit being coupled to it;

d = distance between the two antennæ.

From the above it follows that, if the coupling between antenna and closed tuned circuit is very loose (generally the case in practice)

$$a \propto \frac{I_r}{k} \propto \frac{I_s h_s h_r}{R \lambda d k}, \dots \dots \dots (14)$$

where

a = audibility;¹

k = coupling coefficient between receiving antenna circuit and the receiving closed circuit.

“Selectivity” of a receiving system may be defined as the ratio of the natural wave-length of the transmitting and receiving antenna circuits to the difference between this wave-length and the length of some other wave which (of same field intensity as signal wave) will give a response just audible. Thus, if:

λ_n = natural wave-length of the two antenna circuits;

λ_a = length of wave (of same field intensity as signal wave) which will give a just audible response in the telephone receivers.

S = selectivity,

Then:
$$s = \frac{\lambda_n}{\lambda_n - \lambda_a} \dots \dots \dots (15)$$

It will be seen that selectivity is a measure of how little the reception

¹ This formula is approximate only; actually the audibility does not vary inversely with R because the detector efficiency is involved in the magnitude of R . For a theoretical discussion of the best coupling for detectors of different types the reader is referred to Chapter XV of Pierce's “Electric Oscillations and Electric Waves.”

of signals from a certain transmitting station will be interfered with by the presence of electromagnetic waves of a different wave-length emanating from other stations. Thus if $\lambda_s = \lambda_n$, a condition impossible to realize, then,

$$S = \frac{\lambda_n}{0} = \infty$$

or the selectivity is infinitely large, and no interference will be registered at the receiving station.

It may be shown that when the transmitting and receiving systems are tuned, selectivity is affected by the sum of the decrements of the transmitting and receiving systems¹ and also by the audibility of the receiving circuit (in so far as this is affected by k), approximately as shown by the following formula:

$$S = q \times \frac{1}{\delta_t + \delta_r} \times \frac{1}{a}, \quad (16)$$

where, $q =$ a constant;

δ_t and $\delta_r =$ decrements of transmitting and receiving circuits, respectively;
 $a =$ audibility.

Practically no selectivity can be obtained with the transmitting and receiving systems out of tune.

When making the adjustments of a receiving set the aim should be to obtain the maximum selectivity compatible with a reasonable audibility; but it must be borne in mind that these two quantities are inversely proportional to each other and that a high audibility means a low selectivity and vice versa, as shown by the formula above.

We may now discuss the characteristics of the various types of receivers, of which there are, in general, three:

1st. Those in which the detecting circuit is conductively coupled to the receiving antenna circuit as shown in Fig. 64.

2d. Those in which the detecting circuit is inductively coupled to the receiving antenna circuit, as shown in Fig. 65.

3d. Those in which the detecting circuit is statically connected to the receiving antenna circuit, as shown in Fig. 66.

In all receiving systems the receiving antenna circuit is supposed to be tuned to the wave-length of the incoming oscillations, so that the e.m.f. impressed upon the receiving antenna due to the electro-magnetic waves produce the maximum current.

First Type of Receiver.—In this type, since the energy of the signals received in the antenna is applied directly to the detector circuit without loss on any intermediary circuit, it is plain that comparatively loud signals will be obtained, provided, of course, that the inductance to which the detector circuit is connected is of any reasonable value, so as to produce

¹ See Chapter IV, pp. 272-274.

a reasonable drop across the detector circuit; it has been shown (Fig. 60) that the rectification given by the crystal is proportional to the *square* of the impressed voltage, hence if the inductance used in the antenna for tuning is low, the drop across this inductance will probably be low, so that a poor signal will be obtained. The signal given by the connection will probably be loud and because of the very loudness of the signals, the system must, as already pointed out, be lacking in selectivity. Of course, the selectivity may be improved by making the decrements of the transmitting and receiving antenna circuits low; see Eq. (16).

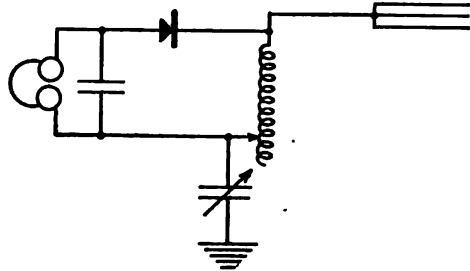

FIG. 64.—Single-circuit receiving system.

Second Type of Receiver.— This may be used either with or without a tuning condenser

in the detector circuit. We will consider the two cases separately. (a) *Without a tuning condenser in the detector circuit.* In this case the audibility of the signals may be changed by changing the coupling between *H* and *K* (Fig. 65); it is superior to the first type because the selectivity may be greatly increased without decreasing the audibility. This is done by using a weak coupling between *H* and *K*, thus increasing selectivity;

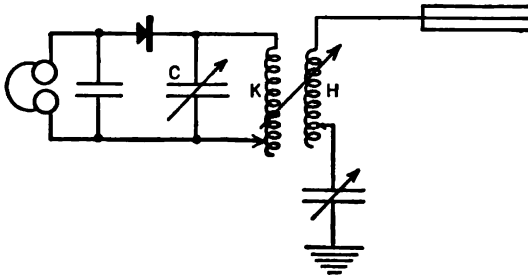

FIG. 65.—Two circuit inductively coupled receiving systems.

the signal is maintained at a loud intensity by winding *K* with many turns of wire compared to the winding of *H*, thus obtaining perhaps much greater voltage across the terminals of *K* than exists across *H*. By thus using high inductance for *K*, getting larger voltage, the efficiency of rectification of

the crystal is increased sufficiently to permit the weak coupling required for selectivity. (b) *With a tuning condenser in the detector circuit.* An increase in selectivity results from this when, as is always the case, the detector circuit is tuned to the receiving antenna circuit, which is, in turn, tuned to the transmitting antenna. For this case it has been found that the selectivity is affected most by the decrements of the detector circuit and of the transmitting antenna, and very little by the decrement of the receiving antenna. This result makes it possible to obtain great selec-

tivity even when the decrement of the receiving antenna is high, by using a *low decrement detector circuit*. On the other hand, if the receiving antenna has a low decrement, then the use of a *tuned detector circuit* has but little advantage, and it would show practically no increase in selectivity over the case where no condenser is used in the detector circuit.

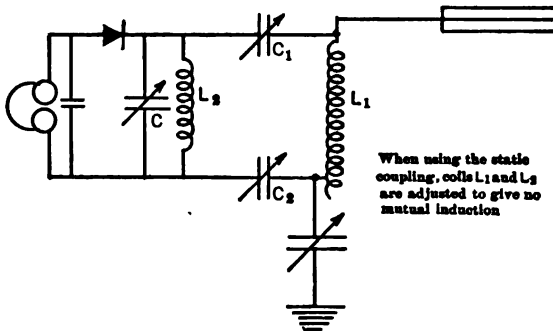

FIG. 66.—Electrically, or capacitively, coupled receiving system.

timer educed. Since the coupling condensers form, together with closed circuit, $L_2 - C$, a circuit which is in multiple with the antenna tuning inductance, it is plain that the total equivalent inductance or capacity of this multiple circuit must be changed somewhat by any change in the coupling condensers, thus affecting the tuning of the antenna circuit.¹

Of the three types of receivers described above the second (inductively coupled type) is most widely used, while the statically coupled receivers were largely used in the U. S. Navy. The first type is never used except when first picking up signals, when the operator may, if the apparatus will allow it, place his detecting circuit directly across the antenna tuning inductance; and later he will change over to the inductively coupled or to the statically coupled type, whichever the case may be.

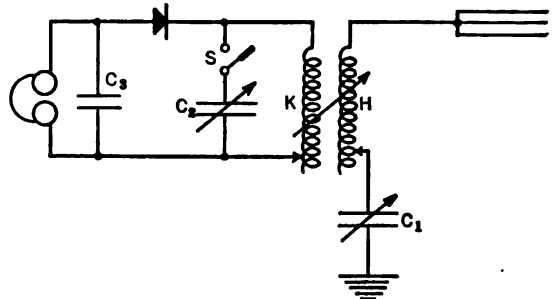

FIG. 67.—Ordinary type of receiving circuit.

We will now give the various steps through which an operator should

¹ For a theoretical treatment of the selectivity of the electrically coupled receiver see article by Louis Cohen, "Electrostatically coupled circuits," Proc. I. R. E., Oct., 1920.

pass when receiving signals, in the case of an inductively coupled receiver. The circuit of this receiver is again reproduced in Fig. 67 for the sake of convenience. To begin with the operator has his set in the so-called "stand-by" position, i.e., with close coupling between H and K and with the switch S open, so as to make the detecting circuit aperiodic; in this condition the operator manipulates the inductance H and the capacity C_1 and picks up practically all signals which reach the antenna with sufficient intensity. When he wants to read a particular signal he goes through the following manipulations: (a) with S open,¹ adjust H and C_1 until required signal is loudest and then the coupling of H and K is decreased to as low a value as possible, still maintaining a fair intensity of signal strength; (b) switch S is closed and C_2 is adjusted until required signal is loudest. (c) Coupling between H and K is decreased and at the same time H , C_1 and C_2 are slightly adjusted until, for any particular coupling, the signal is loudest. This operation is repeated until the legitimate signal becomes quite weak, yet audible, and all the other interfering signals have been weeded out. When going through this last step the interfering signals will, of course, get weaker and weaker as the coupling is decreased from its maximum value, but the audibility may at first increase and then decrease. The reason for this latter is that the antenna and the closed circuit of the receiver form two tuned coupled circuits upon the primary of which (the antenna) there is impressed an e.m.f. of the same frequency as the natural frequency of the coupled circuits; the curves of pages 103 and 104, Chapter I, show that, under these conditions, the current in the secondary (the detector circuit) has a maximum value for a certain critical coupling and that for closer or weaker coupling than this the current becomes smaller.²

In case the wave-length being received is appreciably longer than the natural wave-length of the antenna the shortening condenser C_1 will be short-circuited by a suitably placed switch, and the adjustment of the antenna circuit tuning will be accomplished by varying H only.

Some additional interesting points regarding the effect of the decrease in the resistance of the entire receiving system upon the audibility and selectivity may be deduced by further considering formulas (13) and (16).

$$a \propto \frac{I_s h_s h_r}{R \lambda d k} \dots \dots \dots (13)$$

Formula (13) shows that the less the value of R (resistance of receiving

¹ In case no switch, S , is provided, condenser C_1 may be set at its minimum value; this is practically equivalent to opening switch S .

² The curves given on pp. 103-104 were obtained while an e.m.f. of constant amplitude was impressed on the primary circuit. In the circuit of Fig. 67 a *damped e.m.f.* is impressed as the primary: if the damping is high these curves are not quite applicable to the case.

system) the greater the audibility, and in this respect the effective resistance of the entire receiving system should be kept as low as possible.¹ Again from Formula (16), i.e.:

$$S = q \times \frac{1}{\delta_t + \delta_r} \times \frac{1}{a}, \dots \dots \dots (16)$$

it may be seen that, since the resistance of the receiving system affects the decrement δ , in direct proportion, any decrease of R will decrease δ , and increase S provided, of course, that a is kept constant by suitably changing k . However, since no matter what is done to R the value of δ_t (transmitter decrement) cannot be changed by the receiving operator,

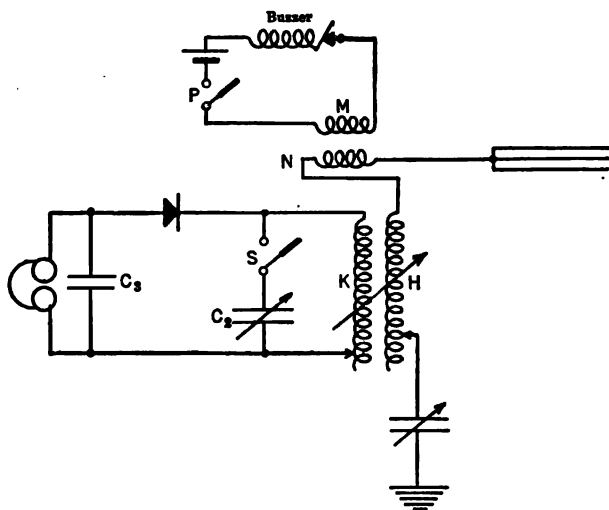

FIG. 68.—Showing arrangement of a buzzer circuit loosely coupled to the antenna, for the testing of the crystal rectifier. With the buzzer in operation the antenna oscillates at its natural frequency and so acts on the receiving circuit as would a signal. Care must be taken to prevent induction from the buzzer circuit getting into the K - C_2 circuit directly as in this case the test is valueless; the buzzer will then be heard in the phones even though the crystal is short-circuited.

it follows that, when δ_t is made very small, there is hardly any gain in selectivity obtainable by making it smaller, because, even if δ_t were zero, there would still remain δ_r to be reckoned with in connection with the value of the selectivity. The conclusion to be derived from the above is that it is uneconomical to try to make the receiving system of extremely

¹ In addition to this condition the resistance introduced into the circuit by the detector and phones should be just equal to the resistance of the entire circuit, exclusive of the detector and phones.

low resistance unless the decrement of the transmitting set is also made correspondingly small.

Another point to be noted is that in most receivers provision is made for adjustment of the crystal detector so as to make sure of a sensitive spot thereon. This is done by arranging the receiving circuit somewhat as shown in Fig. 68, where a buzzer is used to excite by impulse (and by means of coils *M* and *N*) the antenna circuit, so as to produce therein currents of a frequency equal to the natural frequency of the antenna circuit; the currents in the latter are transferred by means of *H - K* to the detector circuit, and the detector may thereby be adjusted for a sensitive point.

Wave-lengths and Ranges in Spark Telegraphy.—The wave-lengths used in spark telegraphy vary from about 50 to about 6000 meters. The range under 200 is allotted to amateurs; 200 to 600 is generally used for aeroplane sets; 450 to 800 for ship sets, 900 to 1500 for moderate-size land stations, and over 1500 for the largest land stations. The laws of the United States specify the following wave-lengths:

High-power stations.....	over 1600 meters.
Navy.....	600 to 1600 meters.
Ship stations.....	300, 450, 600 meters.
Amateurs.....	below 200 meters.

The power used is $\frac{1}{2}$ to $\frac{1}{3}$ kw. for amateur and aeroplane sets, 1 to 10 kw. for ship sets, 5 to 20 kw. for moderate size land stations and up to 100 kw. or more for the largest land stations.

The range covered may be approximately determined by means of the Austin formula given below, which applies to daylight transmission:

$$I_r = 4.25 \times \frac{h_1 h_2 I_s}{\lambda d} \times \epsilon^{-\frac{0.0015d}{\sqrt{\lambda}}} \dots \dots \dots (17)^1$$

where

I_r = the current in receiving antenna in amperes;

I_s = the current in transmitting antenna in amperes;

h₁ and *h₂* = effective heights of transmitting and receiving antennas, respectively, in kilometers;

λ = wave length in kilometers;

d = distance between the two antennas in kilometers.

In the above formula the effective resistance of the entire receiving system

¹ See Chapter IX for further discussion of transmitting formulae. Papers discussing this formula are given by Austin in Bulletin of Bureau of Standards, Vol. 7, No. 3, 1911, and Vol. II, No. 1, 1914, also by Libby in Proc. I. R. E., Vol. 5, No. 1, Feb., 1917. Recent tests by Vallauri throw doubt on the validity of this equation, he having obtained currents about ten times as large as those predicted from this formula.

is assumed to be 25 ohms. In view of the fact that the distance (d) occurs as an exponent it is difficult, more particularly for large distances, to solve the above equation directly for d . The following may, however, be done. Knowing h_1 , h_2 , I_s and λ , plot a curve showing the relation between d and I_r . The value of d , obtained from the curve, corresponding to an I_r , which will give the minimum audibility (this depends on the type of

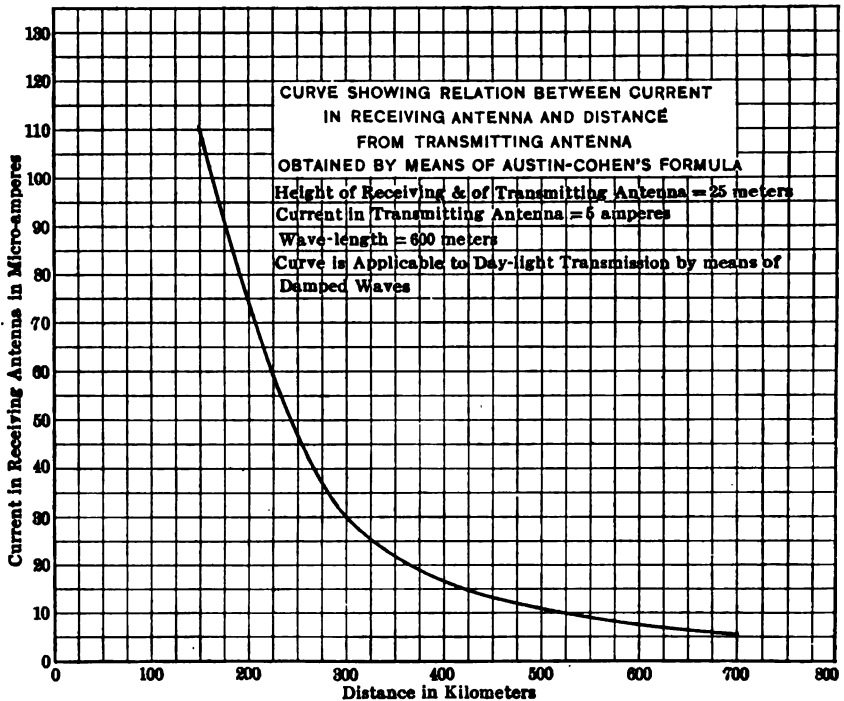

Fig. 69.—Calculated value of current in the antenna of the receiving station as distance is varied, the conditions being as stated in the diagram.

detector used) is the maximum range. An example has been worked out below, where:

$$h_1 = h_2 = 0.025 \text{ km.}$$

$$I_s = 5 \text{ amperes}$$

$$\lambda = 0.6 \text{ km.}$$

and

$$I_r = 4.25 \times \frac{0.025^2 \times 5}{0.6 \times d} \times \epsilon^{\frac{0.0015d}{\sqrt{.6}}} = \frac{22,100}{d} \times 10^{-6} \times \epsilon^{-0.00194d}.$$

Substituting different values of d in this last equation we obtain the corresponding values of I_r and are, therefore, able to plot the curve of Fig. 69.

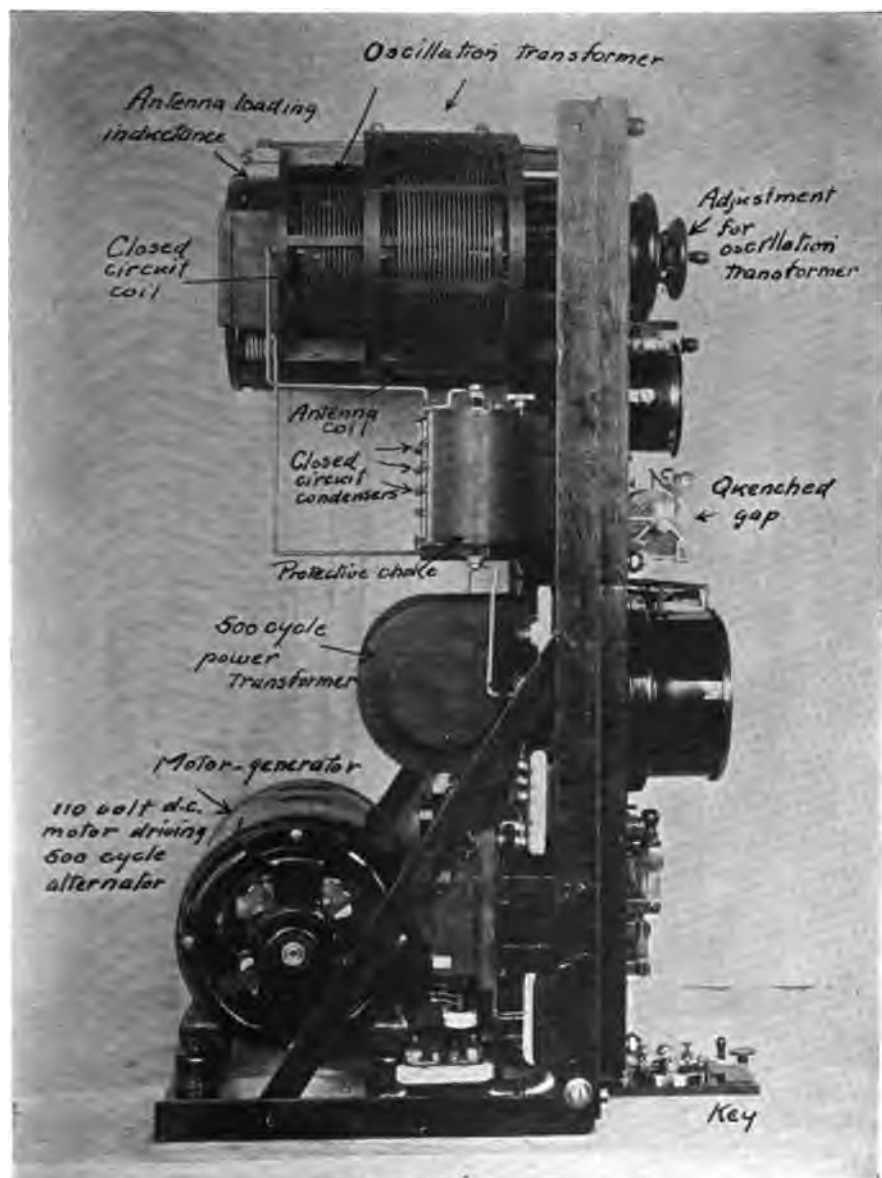

FIG. 70.—Side view of a small spark set made by the Wireless Improvement Co.

With an ordinary crystal detector and a receiving system of 25 ohms a current of 7 micro-amperes in the receiving antenna is sufficient to give unit audibility. Looking up the curve we find that the distance corresponding to 7 micro-amperes is 610 km.'s.

If strays and interference should be present perhaps 28 micro-

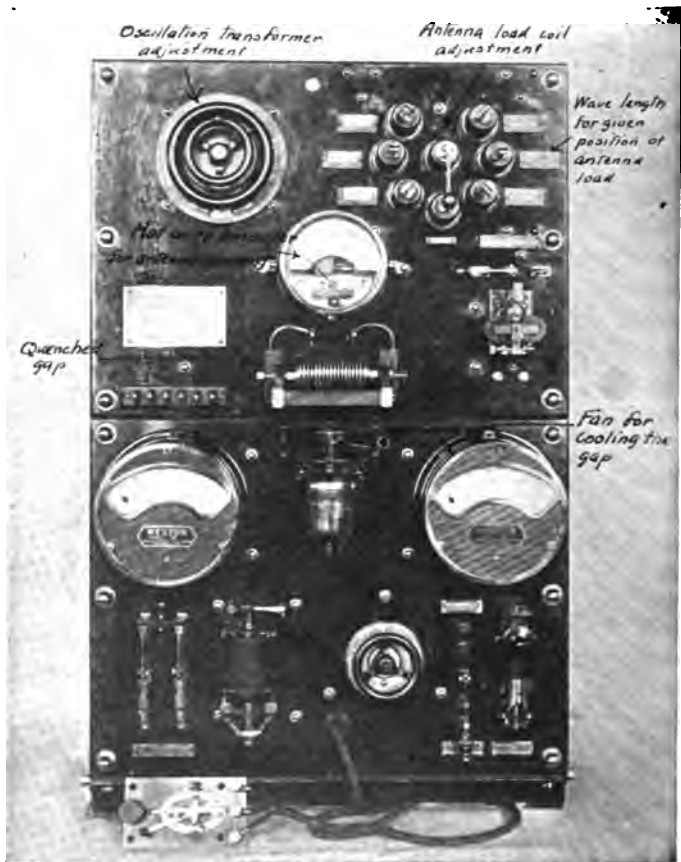

FIG. 71.—Front view of the set shown in Fig. 70.

amperes might be required in the receiving antenna in order to insure reliable communication, in which case the distance would be 310 km.'s.

Thus, for daylight transmission, under poor atmospheric conditions, the range would be about 300 km.'s, and under very favorable atmospheric conditions the range would be about 600 km.'s.

From the point of view of the transmitter in the problem considered above, the high-frequency power in the antenna for a current of

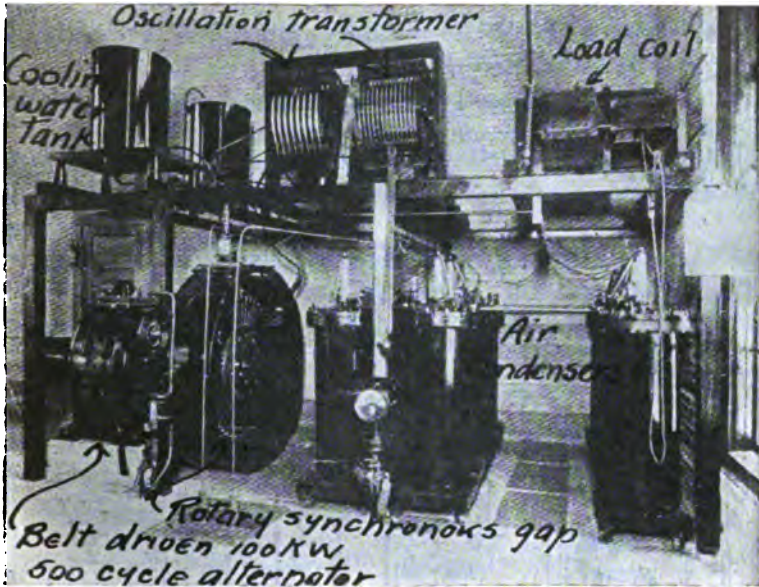

FIG. 72.—General view of the spark transmitter used at the U. S. Government station at Arlington for broadcasting time signals and weather reports.

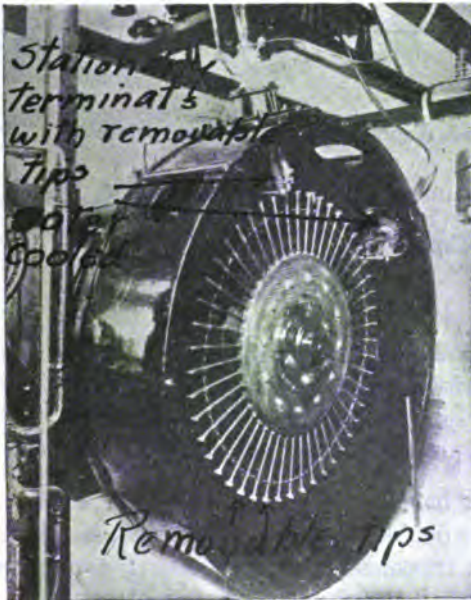

FIG. 73.—Showing the construction of the synchronous rotating gap of the Arlington transmitter.

5 amperes in the antenna and assuming the total resistance of the antenna to be 8 ohms, would be given by:

$$\text{High-frequency power} = 8 \times 5^2 = 200 \text{ watts.}$$

Assuming efficiency of the transmitting set from alternator to antenna = 25 per cent.

$$\text{Alternator output} = \frac{200}{.25} = 800 \text{ watts.}$$

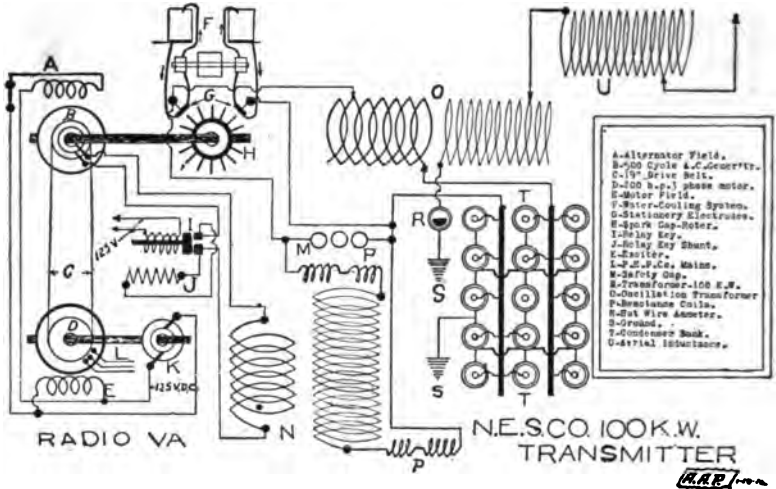

Fig. 74.—Circuit diagram of the Arlington transmitter. (Proc. I.R.E.)

It must be noted, in connection with the above, that if we neglect the factor $\epsilon^{-\frac{0.0015d}{\sqrt{\lambda}}}$, in Eq. (17)

$$d = 4.25 \times \frac{h_1 h_2 I_s}{\lambda I_r}, \dots \dots \dots (18)$$

then, if everything else be kept constant the distance would vary directly with the transmitting antenna current (I_s); but the power required from the alternator varies with the square of the current, hence to double the transmitting distance the power put into the antenna must be quadrupled; and, if the factor $\epsilon^{-\frac{0.0015d}{\sqrt{\lambda}}}$ be considered, the power must be more than quadrupled to double the range of transmission. Hence, the necessity for great range of transmission of increasing the antenna heights (more especially the transmitting antenna) to very great values.

Arrangement of Apparatus of a Spark Set.—The various parts required for a transmitting set are generally assembled in compact form; in the

case of a low-powered outfit practically all of the apparatus, with the exception of the hand key for sending, may be mounted directly on a panel. A neat design for a 500-watt, quenched-spark transmitter is shown in Figs. 70 and 71; the legends on the cuts makes them self-explanatory. The larger land stations of course require large switch boards and auxiliary apparatus, in fact the outfit really comprises a complete isolated power plant equipment.

In Fig. 72 is shown the arrangement of apparatus of the Arlington spark set, used for sending out time signals; Fig. 73 gives a closer view of the rotating synchronous spark gap and Fig. 74 gives a complete circuit diagram of this station.

CHAPTER VI

VACUUM TUBES AND THEIR OPERATION IN TYPICAL CIRCUITS¹

Constitution of a Conductor, Possibility of Electron Emission.—As outlined in Chapter I, a conductor is made of atoms (or molecules) with some of the electrons free from atoms, moving back and forth, from one atom to another. Unless the conductor is at absolute zero temperature its atoms are constantly in a state of agitation, having non-coordinated motions in all directions. The free electrons share the motion of the atoms, and due to their comparatively small mass (about $1/200,000$ that of the tungsten atom) their average velocity is very much greater than that of the atoms.

Now the atoms of a metal tend to separate from each other at high temperatures or, we may say, the metal tends to evaporate just as water evaporates at ordinary temperatures. We must imagine the surface tension of a metal great enough to prevent appreciable evaporation at ordinary temperature; the velocity of motion of the atoms is not sufficient to carry them through this surface tension. With very high temperatures, however, those atoms having the highest velocity break through the surface tension and so start the process of vaporization, which becomes more and more rapid as the temperature rises. To accomplish actually the vaporization of the ordinary metal requires that the heating be done in vacuum, otherwise oxidation occurs instead. The number of atoms evaporated from a given surface depends upon the temperature and the latent heat of evaporation of the metal being tested.

Now it seems quite likely that if, when the atoms acquire a high velocity, they are able to break through the surface tension of the metal the electrons can do the same thing, hence we get the idea of *electrons evaporating*.² This evaporation of the electrons will take place at lower temperature than that of the atoms of the metal itself because of the higher average velocity of the electrons.

Theoretical Prediction of the Number of Electrons Emitted from a Hot Body.—The number of atoms (or molecules) of an ordinary liquid

¹ Since this material went to press there has been published an excellent text on Vacuum Tubes by H. J. Van der Bijl.—McGraw-Hill Co.

² See O. W. Richardson's book on "The Emission of Electricity from Hot Bodies."

which evaporate was known to vary with the latent heat of evaporation of the substance and temperature according to the equation,

$$N = A \sqrt{T} \epsilon^{-\frac{a}{2T}}$$

where

- N = number of atoms evaporating per second per sq. cm. of surface;
- T = absolute temperature, ordinarily called degrees Kelvin;
- a = latent heat of evaporation;
- A = a constant.

Richardson was the first to draw an analog between the evaporation of atoms and possible evaporation of electrons from a hot metal. Reasoning from the above equation he came to the conclusion that the number of electrons evaporating per second (current) could be expressed by the equation

$$i = a \sqrt{T} \epsilon^{-\frac{b}{2T}}, \quad (1)$$

in which

- i = current of emission per sq. cm. of hot surface;
- T = absolute temperature of hot metal;
- b = latent heat of evaporation of electrons = 105,000;
- a = a constant.

As this predicted current was due to the thermal activity of the emitting surface Richardson suggested the term *thermionic current*, a name which is at present used to some extent; the term *electron current* is also used, but this is really not distinctive, because all currents, arising from whatsoever cause, are due to the flow of electrons.

The emission of electrons predicted by Eq. (1) would give currents from a heated tungsten filament about as shown in Fig. 1; it is evident that very large currents might be expected from a tungsten filament at temperatures well within the safe operating region.¹ Of course, ordinarily there is no current of such magnitude due to emitted electrons; although the number of electrons indicated in Fig. 1 is really emitted, they at once re-enter the surface so that on the whole there are no electrons leaving the hot surface. As soon as an electron leaves the filament it (the filament) is left charged positively and so attracts the emitted electron; thus there are as many electrons falling back into the filament as are expelled by the internal thermal agitation.

¹ The melting-point for tungsten is 3270° C.; reckoning the safe operating temperature as that which gives the filament 2000 hours' life, the safe temperature increases somewhat with the diameter of the filament, being perhaps 2200° C. for a filament .01 cm. diameter and 2300° C. for one .04 cm. diameter.

Suppose, however, that there is, close to the heated filament, a positively charged metal plate; an expelled electron will have two forces acting on it, one tending to make it fall back into the filament, and the

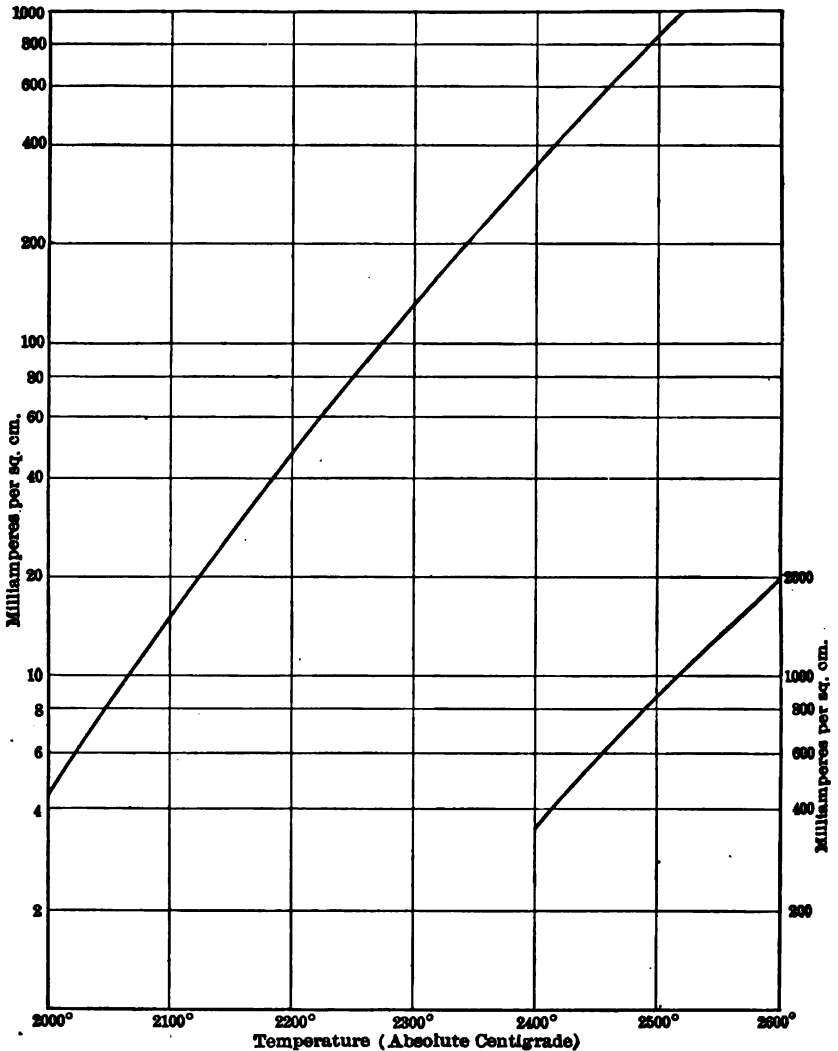

FIG. 1.—Theoretical values of current due to electron emission from a pure tungsten filament.

other pulling it toward the positively charged plate. Which force has the preponderating effect will depend, of course, upon the value of the positive plate potential; if this is made sufficiently high, all of the electrons

emitted from the hot surface will be drawn to the plate, none of them re-entering the hot emitting surface.

The value of the current under this condition is called the *saturation current*; this value of current measured for different filament temperatures should satisfy Richardson's equation because all of the electrons emitted go over to the plate.

As early as 1902 Richardson published experimental results confirming his theory. Many other experimenters published results seemingly contradicting the relations given in Eq. (1), and for several years Richardson's theory was the subject of dispute.

It seems that very minor changes in the amount of gas in the tube used, or the condition of the surface of the hot metal, completely nullified the results obtained, and such has been found to be the case. H. A. Wilson found, e.g., that the emission from a hot platinum filament might be reduced to 1/250,000 of its normal amount by first heating the filament in oxygen, or boiling it in nitric acid; also he found that the presence of a slight amount of hydrogen around the heated filament completely destroyed the effects of the oxygen and nitric acid. On the other hand it is found that the electron emission from tungsten is very much increased by such an impurity as thorium; if a small percentage of thorium is present in a tungsten filament the emission is many times as great as though pure tungsten were used.

As a result of Wilson's experiment it was evident that the condition of the hot surface was of utmost importance in determining the emission; the layer of oxygen-filled platinum on the surface practically prevented emission. Yet a year afterward Wehnelt showed that if a platinum filament was coated with lime (calcium oxide) the emission of electrons at a given temperature was vastly greater than from the platinum itself.

Langmuir's experiments, performed with tungsten filaments in extremely high vacuum, proved without doubt the truth of Richardson's prediction and indicated that the various experimenters whose tests had showed the opposite had not been careful enough in the manipulation of their experiments and in the interpretation of the results. He found that the higher the vacuum the more consistently did experiment and theory agree, whereas others had concluded that gas was absolutely essential if the thermionic current was to be obtained. In one of Langmuir's tests he showed that the presence of only .000001 mm. pressure of oxygen was sufficient practically to stop the emission of electrons from a hot tungsten filament. It seems then that the condition of the surface of the hot electrode affects the emission of electrons much as the evaporation of water is prevented by covering the surface with a thin layer of oil or similar substance.

Distribution of Electrons near the Surface of a Hot Metal.—In Fig. 2 is shown, in rather crude fashion, the manner in which the electrons are concentrated near the surface of a hot body, the three figures being for

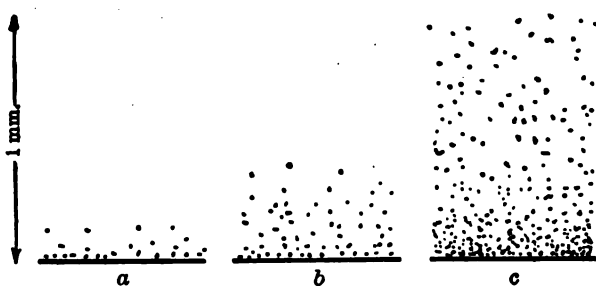

FIG. 2.—Conventional diagram to represent the distribution of electrons near the surface of a hot metal, for increasing temperature.

perhaps .001 cm. In (b) more electrons are emitted and their mean velocity has increased so that more of them move farther away from the surface before falling back. In (c) is shown a much denser electron atmosphere near the surface and also extending to considerable distance from the tungsten surface. In one tungsten filament tube tested by the author it was found that at normal operating temperature only 1/8000 of the electrons emitted reached a distance .15 cm. from the hot filament, most of them never going very far (perhaps .001 cm.) from the surface.

temperatures of perhaps 2100°, 2300°, and 2500° absolute temperature. In (a) but few electrons are coming off and these have such a low velocity that they are pulled back into the tungsten before they have moved out from the tungsten

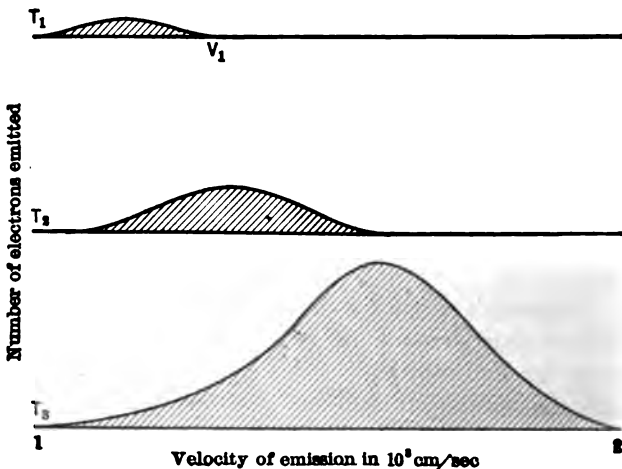

FIG. 3.—Velocity distribution for electrons emitted from hot tungsten, for three different temperatures.

In Fig. 3 is shown a set of curves corresponding to the conditions given for Fig. 2; the area under each curve gives the numbers of electrons emitted from the filament and the form of the curve illustrates how the number of electrons having a given velocity changes as the temperature is increased. At temperature T_1 , but few electrons are emitted and they

have on the average a low velocity, practically none having a velocity greater than V_1 ; at temperature T_2 , many more electrons come off and on the average they have a higher velocity; the same effect, but more of it, is shown for the highest temperature T_3 .

Some idea of the velocity with which these electrons leave the surface of the tungsten can be easily obtained. From certain experiments we know that an electron must fall freely through a potential difference of about 4 volts, before it gains sufficient energy to break through the "surface tension" or "surface constraint" of the metal. If we use the relation that, in any accelerating system,

$$\text{Potential energy lost} = \text{kinetic energy gained}$$

$$\text{we put} \quad Ve = \frac{1}{2}mv^2$$

in which

V = potential difference through which electron has fallen (e.s. units);

e = charge of electricity on one electron;

m = mass of electron;

v = final velocity of electron, assuming it to start from rest.

Transposing we get $v^2 = 2V \frac{e}{m}$ and $\frac{e}{m}$ has been determined many times, its value being 5.3×10^{17} .

Hence if an electron falls through one volt difference of potential (1 volt = $\frac{1}{300}$ e.s. unit) the above relation gives v approximately 5×10^7 cm./sec.

As the surface constraint of tungsten is about 4 volts we see that an electron, to break through, must have a velocity of about 1×10^8 cm./sec.

If a cold metal plate, electrically connected to the filament outside the tube, is in the same vacuum tube as the hot filament, and close to it, some of the high-speed electrons may have sufficient velocity to carry them from the hot filament to the cold plate; they then flow along in the circuit connecting the plate to the filament. This thermionic plate current can exist even though the plate is at the same potential as the lowest potential point in the filament. Such an effect is shown in Fig. 4; the amount of the plate current recorded was due to electrons emitted from the filament with such a high velocity that their inertia carried them across the .2 cm. space separating the plate from the filament.

It will be noticed how the number reaching the plate increases rapidly with the value of filament current, due to the two effects mentioned above, greater emission and higher velocity of emission. The total emission of electrons from the filament for various filament currents is noted on the curve sheet of Fig. 4; above a filament current of 1.36 amperes

this total emission could not be accurately measured, for reasons to be taken up later. The filament used in getting the curve of Fig. 4 was only about 3 cm. long and of approximately the same diameter as that of a 100-watt tungsten lamp, yet it will be found by calculation from the values given on the curve sheet that at 1.3 amperes in the filament the emission was about 4×10^{17} electrons per second, and of this number there were

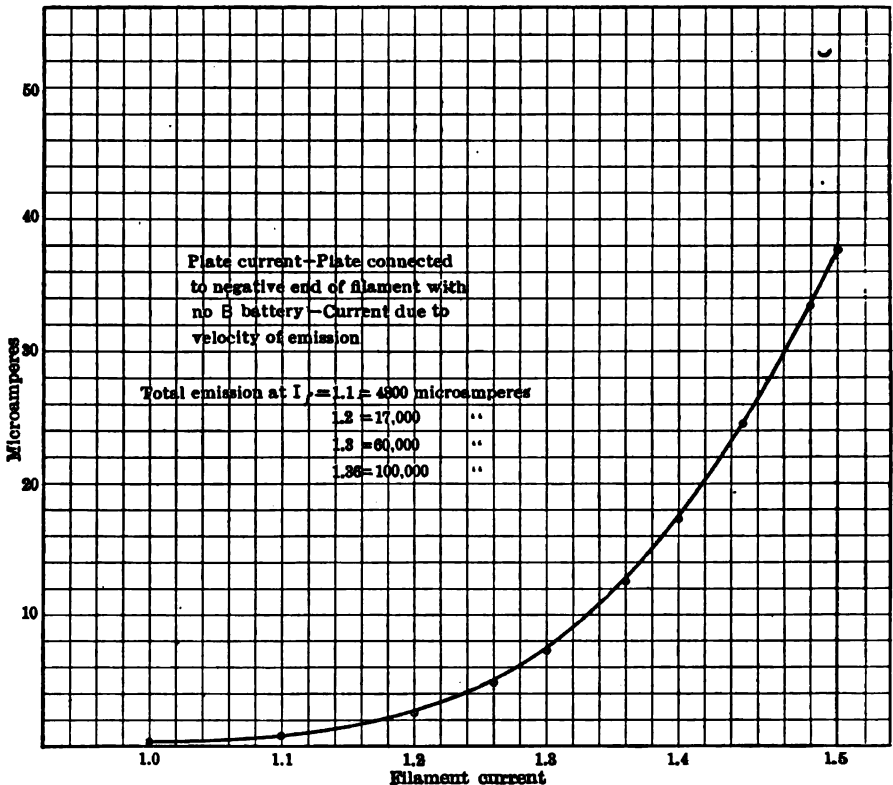

Fig. 4.—Electron current from a hot filament to an adjacent cold plate, at the same potential as the lowest potential of the filament. Current due to velocity of emission of the electrons.

4×10^{13} which had sufficient velocity to carry them away from the filament an appreciable fraction of a centimeter.

From the previous analysis of electron emission from a hot body it will be realized that the condition close to the surface of a hot filament resembles very much the atmosphere surrounding the earth, a depth of earth atmosphere of one kilometer corresponding to a depth of "electron atmosphere" of about 0.01 millimeter. Just as the earth's atmosphere becomes less dense with increase of distance from the surface, does the

density of electrons decrease with increase of distance from the filament; the upper part of the earth's atmosphere contains the more rapidly moving atoms of gas just as is the case of the high-speed electrons getting farther away from the filament than those emitted with lower velocity.

Power Required to Produce Emission.—From what has been said it is evident that the power required (for heating the filament) per ampere of emission varies greatly with the temperature of the emitting surface; thus with a red-hot tungsten filament the emission is inappreciable, although the power required for maintaining the filament red-hot is comparatively large.

As the tungsten approaches a white heat the emission increases much more rapidly than does the required power for heating the filament. By changing the filament temperature from 2100° Kelvin¹ to 2400° Kelvin the emission is increased about 23 times, whereas the required power to heat the filament has increased only about 75 per cent. It is therefore advisable to run the emitting surface at the maximum safe temperature, consistent with reasonable life of the filament. Dushman² has given the following values as representative of reasonable operation of a tungsten filament, the life of the filament being fixed as 2000 hours:

Diameter of Filament in Cm.	Safe Temperature Degrees Kelvin.	Emission in Amperes per Cm. Lengths.	Power Required for Heating Filament, in Watts per Cm.
.0125	2475	.63	3.1
.0175	2500	.05	4.6
.0250	2550	.10	7.2
.0375	2575	.20	11.3

From what experimental data the author has been able to obtain himself it seems as though these figures are rather optimistic; when operated at the temperatures given in the above table it seems as though the life of the filament is considerably less than the life of 2000 hours estimated by Dushman.

Two-electrode Vacuum Tube.—The property of hot bodies *in vacuo* permitting passage of electrons to a cold electrode in the same vessel was originally called the Edison effect; it was noticed in incandescent lamps as early as 1884. In 1896 Fleming gave the results of a series of experiments in thermionic currents through *vacuo*, but it is evident in the light of our present knowledge that a large part of the current measured by him was due to conduction by the ionized gas in the tube he was using. He found some characteristics which were really due to the electron emis-

¹ 2100° Kelvin = 2100° C. absolute.

² See article by Dushman in *General Electric Review*, March, 1915.

sion, notably the unilateral (one direction only) conductivity of the apparatus, the non-linear relation between the plate potential (with respect to the filament) and the plate current, and the fact that a large separation of plate and filament tended to reduce the amount of plate current obtainable. He found, however, that the plate current was unstable and that the better the vacuum the less the plate current became; both of these effects show that ionized gas was largely responsible for carrying the plate current. The unilateral conductivity of a vacuum tube having two electrodes, one hot and the other cold, was utilized by Fleming for the detection of damped high-frequency waves and was patented by him in 1905. This patent was a very important one in the field of radio telegraphy; it goes by the name of the "Fleming valve" patent. A cut showing a

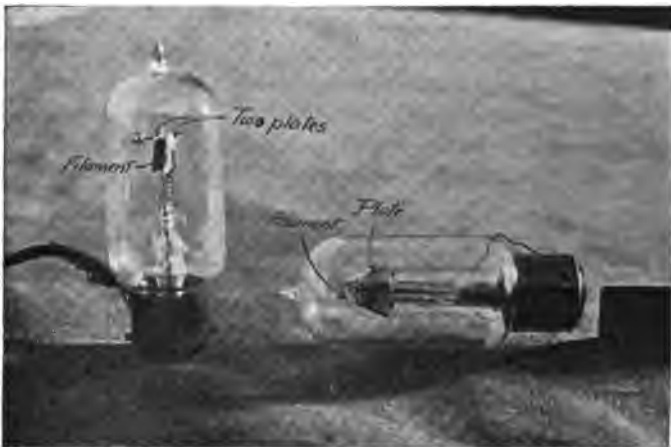

Fig. 5.—One type of Fleming valve, used on early Marconi receiving sets as detector.

Fleming valve is given in Fig. 5. More recent devices which function because of the unilateral conductivity between hot and cold electrodes in a vacuum are the mercury rectifier, the tungar rectifier and the kenotron.

The *mercury rectifier* uses a hot spot on a pool of mercury as the source of its electrons, the necessary temperature of the hot spot being maintained by heat caused by the plate current itself; ionized mercury vapor serves as the carrier of the current which can pass one way only.

The "*tungar*" *rectifier* operates in a manner different from that of the mercury rectifier, in that a hot tungsten filament serves as the source of electrons, this filament requiring an auxiliary source of power for maintaining its requisite temperature. The tube is filled with an inert gas

(generally about 2 lbs. absolute of argon), and this gas is ionized by the electrons from the hot filament; the carrier of the plate current is in this case also ionized gas for the main part, the number of electrons emitted from the hot filament being sufficient to carry perhaps 1/500 of the current to the plate.

The *kenotron* is a rectifying tube which really operates as a thermionic valve; the tube is exhausted as thoroughly as possible, so much so that whatever gas may be present plays an unimportant role in the functioning of the device. The plate current is never greater than that actually emitted by the hot filament. These rectifying tubes are made in large sizes, sufficient to rectify several kilowatts of power; the vacuum in these is so high that no appreciable current is carried in the reversed direction (electrons from plate to filament) even if 100,000 volts is impressed.

In small sizes they have been used as voltage regulators for self-excited generators, the speed of which is variable. By having a differential winding on the field poles, which is supplied with current through a regulator tube, and connecting the filament of this regulator tube across a low-voltage winding on the armature, a small generator may be made to maintain practically constant voltage over a wide range of speed variation. The scheme of connection is shown

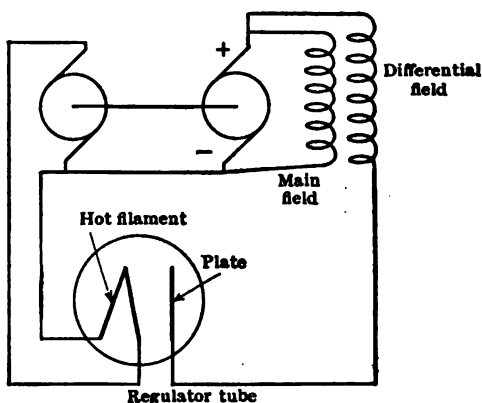

FIG. 6.—Use of a two-electrode tube as a voltage regulator for a variable speed generator.

in Fig. 6, and the reasons for the tube maintaining such constant voltage over such a wide speed range will appear from an examination of the characteristics curves of such a tube.

Characteristic Curves of a Two-electrode Vacuum Tube—Value of Saturation Current.—If the filament current of a kenotron is maintained constant and plate voltage varied, readings being taken of plate voltage (with respect to the filament) and plate current, curves will be obtained having the shape shown in Fig. 7; here three curves are shown for three different filament currents as noted on the curve sheet. The tube from which these curves were obtained is shown in Fig. 8; the plate is a cylinder about .5 cm. by 1.5 cm. and the filament is a helix inside this cylindrical plate.

Curve 1, Fig. 7, shows the variation of plate current for a filament cur-

rent of 1.15 amperes; it is evident that as the plate voltage is increased from zero the plate current rises more rapidly than the first power of the

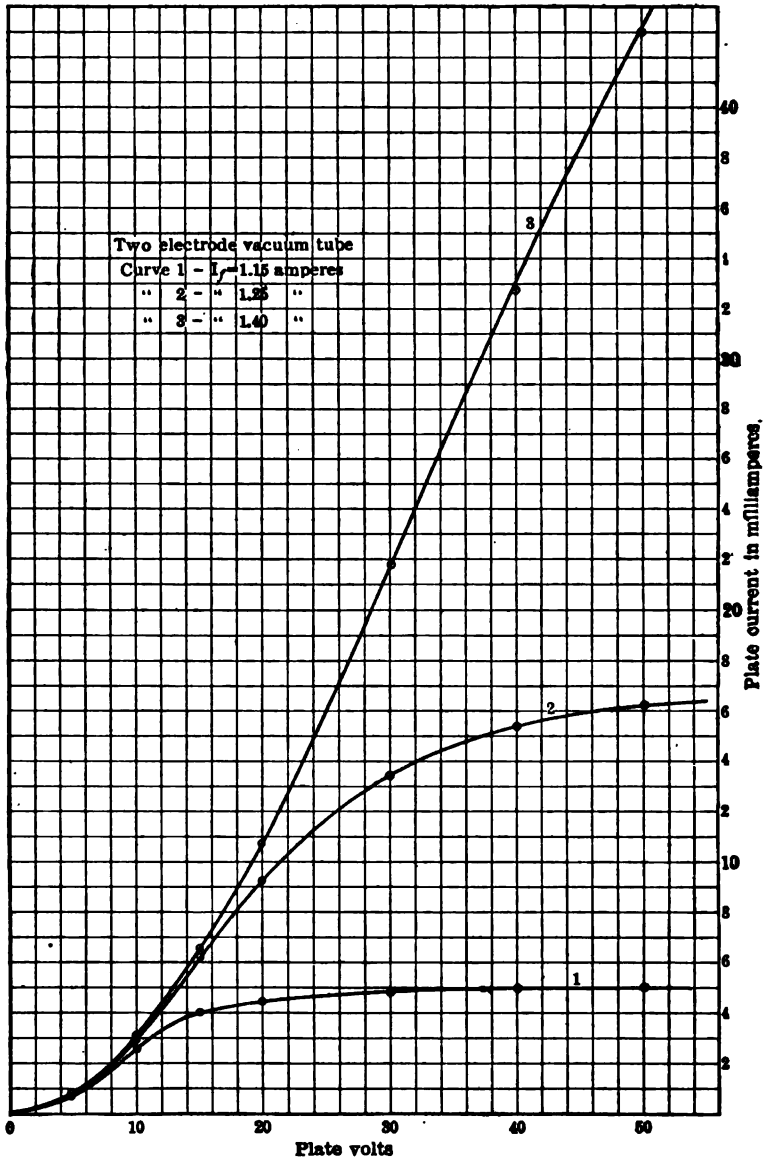

FIG. 7.—Variation of plate current with plate voltage (for various filament currents) in a small kenotron.

voltage until about 10 volts is impressed; for higher voltage a smaller increase in plate current is obtained and above 30 volts no further increase

in plate current is obtained, even if the plate voltage is increased to 300 volts. It is evident that a plate voltage of 30 is sufficiently high to attract to the plate *all the electrons which the filament emits*, at the temperature reached with a filament current, I_f , of 1.15 amperes. This value of plate current, which is limited only by the emitting power of the filament, is called *saturation current of the tube*.

Saturation current evidently will be determined in magnitude by the temperature and area of the filament surface; also for higher filament temperatures (higher emission) it will require higher plate voltage to obtain saturation current; thus when I_f is raised to 1.25 amperes saturation current is increased from 5 milliamperes, its value for $I_f = 1.15$ amperes, to about 16.5 milliamperes, and whereas in the first case 30 volts on the plate was sufficient to obtain saturation current, in the second case even 50 volts was not quite sufficient to reach saturation.

When I_f was increased to 1.40 amperes, the emission was so great that a plate voltage of 50 was not nearly enough to obtain saturation current and the value of saturation current is going to be very high, judging from the shape of the curve. Its value was actually determined in another test and found to be 140 milliamperes.

Considering curve 3 of Fig. 7, it is apparent that for any plate voltage shown on the curve sheet, the number of electrons arriving at the plate is only a small fraction of the number emitted by the hot filament; e.g., with a plate potential of 20 volts the current to the plate was only 10.8 milliamperes, whereas the total emission of electrons from the filament is sufficient to give a plate current of 140 milliamperes. It is therefore evident that to obtain at the plate all the electrons emitted from the filament a certain minimum voltage must be impressed on the plate. The



FIG. 8.—Showing the kenotron from which the curves of Fig. 7 were obtained.

reason for this is given by an analysis of the electron distribution between the hot filament and cold plate.

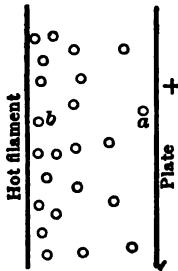

FIG. 9.—Elementary representation of the distribution of electrons between the hot filament and cold plate of a kenotron.

Space Charge.—In Fig. 9 is shown in very elementary fashion the distribution of electrons between the plate and filament; we will consider the electric forces acting on two of the electrons *a* and *b*. Electron *a* is urged to the plate by two forces, the attraction from the plate and the repulsion from all the electrons between it and the filament; it will undoubtedly go to the plate. But electron *b*, although attracted by the plate, is repelled by all the electrons between the plate and itself; whether it will move toward the plate or re-enter the filament depends upon the relation between these two forces. It is evident that close to the surface of the filament the effect of all the electrons in the space between the filament and the plate (constituting the space charge) will practically neutralize any effect of the plate, unless the plate voltage is high enough to give a force of attraction greater than the repulsive force exerted by the space charge.

There is another way of looking at the problem; to bring the plate to a certain potential with respect to the filament requires a certain quantity of electricity, determined by the electrostatic capacity of the condenser formed by the plate and filament. Suppose this quantity of "positive" electricity is q , there will be then $4\pi q$ lines of electrostatic force leaving the plate, in the direction of the filament. These lines of force must end on q charges of negative electricity; but if the space charge is sufficiently large to furnish the requisite q the lines of force from the plate never penetrate to the filament.

An attempt to picture this is made in Fig. 10; for the picture as drawn electron *a* experiences no force at all from the plate, and so does just the same as it would if the plate were not there, i.e., goes back into the filament. But if the plate is brought to a higher positive potential, by putting more charge on it, more lines of force will emanate from the plate and so some may end on electron *a* and so attract it to the plate. It must be remembered that the above picture of what happens is very crude and artificial; the lines of force really have no entity and *a* is

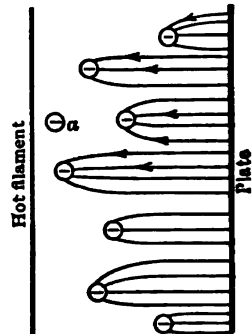

FIG. 10.—If there are sufficient electrons between the plate and filament, the lines of force from the plate do not penetrate as far as the filament, thus leaving some electrons near the filament free from attraction to the plate.

attracted, to some extent, by the plate for the condition shown in Fig. 10, but the attraction is negligibly small.

It has been shown by Child¹ that when the emission of the electrons from the filament is much greater than that required by the plate current, the plate current may be expected to vary according to the relation

$$i = K \frac{E^{3/2}}{x^2}, \quad \dots \dots \dots (2)$$

in which

E = potential of plate with respect to filament;

x = distance between filament and plate.

When E is measured in volts and x in centimeters this becomes,

$$i = 2.33 \times 10^{-6} \frac{E^{3/2}}{x^2} \text{ amperes per sq. cm. of plate.} \quad \dots (3)$$

If the plate is cylindrical in form with the hot filament placed in its axis this relation becomes,

$$i = 14.65 \times 10^{-6} \times \frac{E^{3/2}}{r} \text{ amperes per cm. length of cylinder,} \quad \dots (4)$$

where r = internal radius of cylinder.

The diameter of the filament is supposed small compared to the diameter of the cylinder in getting this formula.

If we have an equation in the form $x = y^a$ we have also $\log x = a \log y$, so that if the data for the curve $x = y^a$ are plotted on logarithmic coordinate paper the curve should become a straight line, the slope of which gives the value of the exponent a . Curve 3 of Fig. 7 was transposed to logarithmic paper and is shown in Fig. 11; it is seen that the exponent itself is variable, having a value about 2 for low plate voltages and rapidly decreasing for the higher values.

It could not be expected that the experimental results would agree with theory, because *the voltage between the plate and filament is different in different parts of the filament.*

This point must be borne in mind in interpreting all experimental results on vacuum tubes; practically all theoretical conclusions are reached from the premise of *uniform potential gradient* between the plate and all parts of the surface emitting the electrons. For the lower plate voltages this assumption is not even approximately true. The tube used in getting the results shown in Fig. 7 had an IR drop in the filament of 6 volts so that the potential relations in the tube may be about as shown in Fig. 12. The voltage difference is 20 at the negative end of the filament and only

¹ Physical Review, Vol. 32, p. 498.

14 at the positive end, having values between 14 and 20 at the intermediate points.

For such tubes we cannot expect to get theoretically correct results for the performance under any conditions; especially when the characteristic varies with the plate voltage to a power higher than the first (as the $3/2$ or square) the departure of experiment from theory must be expected.

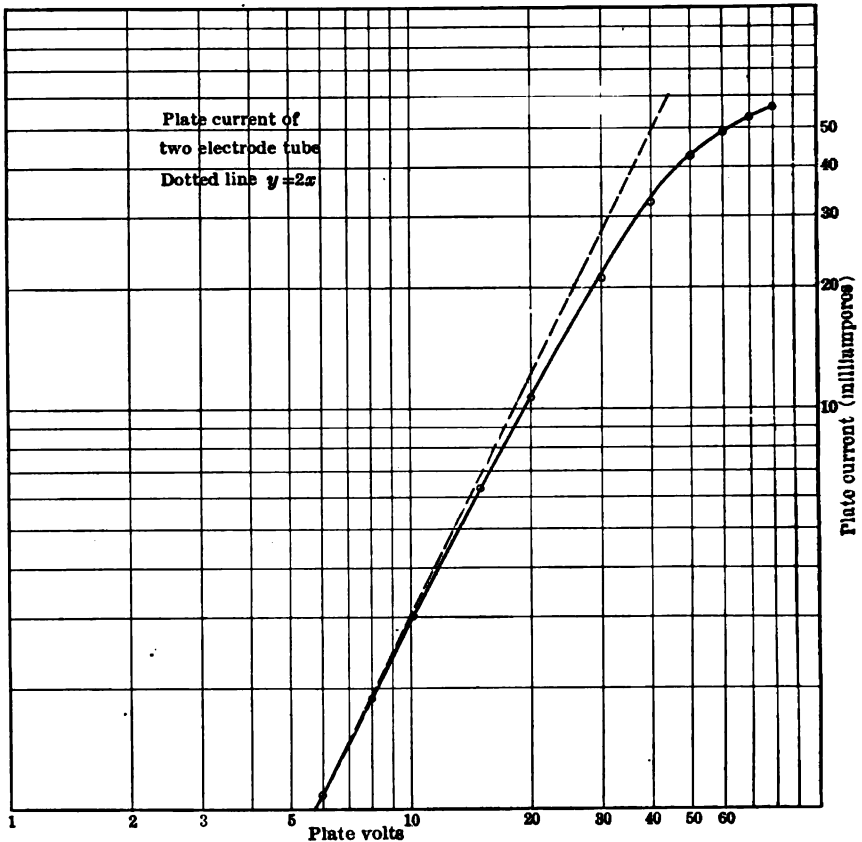

FIG. 11.—Curve 3 of Fig. 7 transposed to logarithmic coordinates.

The author built a tube as shown in Fig. 13 in which the spiral tungsten filament *A* used for heating was entirely enclosed in a tungsten thimble *B*; this thimble constituted the hot surface from which the electrons were emitted. Such a construction gives a uniform potential gradient between the emitting surface *B* and the cylindrical plate *C* and so permits experimentation under the conditions assumed in theory. With this construction it is not possible to get the tungsten thimble as hot as the filament

and so the emission is rather low, unless an oxide coating is used on the thimble. Such a construction permits the use of a high-voltage filament and, a much more important point, *the electron current from the hot surface is not directly limited by the carrying capacity of the filament.* As will be explained later this feature becomes important in high-power tubes; in these tubes the electron current to the plate may be as high as 12 to 15 per cent of the filament current, so that the filament current is 12 to 15 per cent greater at one end of the filament than it is at the other end.

It is shown in the next paragraph that a tungsten filament does not give appreciable emission until it is very hot, so that we may have conditions as shown in Fig. 14; the arrows indicate the direction of electron flow. With a plate current of 0.5 ampere the tube in question has a current of 3.3 amperes at

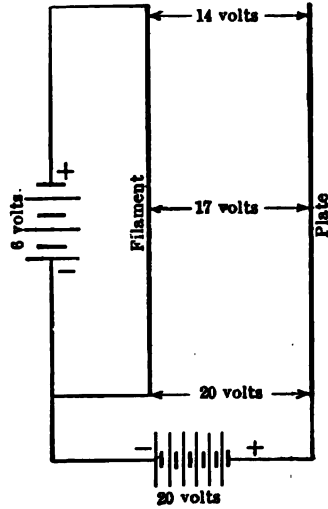

FIG. 12.—Variation of potential drop between the plate and different parts of the filament; the drop at one end of the filament is 14 volts and at the other end is 20 volts.

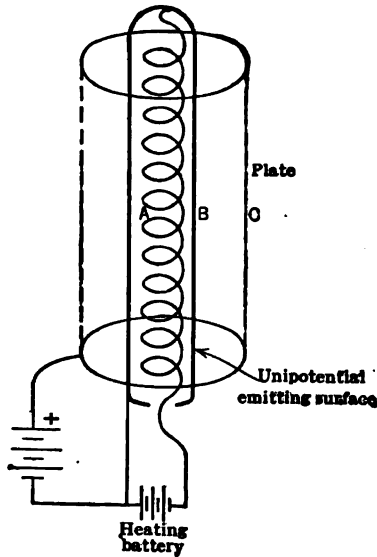

FIG. 13.—Showing one scheme for getting a unipotential surface emitting electrons; the electrons come off from the thimble B, which is heated by the filament A.

one end and 3.8 amperes at the other end, as indicated in the diagram. End B of the filament is at a much lower temperature than end A, and is contributing but little of the plate current, as the emission is too low. End A, on the other hand, is furnishing most of the plate current and is also being operated at much too high a temperature. With a tube as shown in Fig. 13, the filament proper suffers no loss of electrons, so has the same current throughout its length.

Variation of Emission with Filament Current.—Curves Showing Space Charge Effects.—The variation of emission with filament temperature is indicated in Eq. (1), but the experimenter generally has no means of measuring the temperature of the filament; the curves given in Fig. 15 show how the emission varies with filament current; in these curves is also shown the effect of space

charge limiting the plate current. It is evident that the filament used in this tube gives practically no emission with currents less than 1.0 ampere. With a plate voltage of 100 the plate current rose rapidly with increase in filament current reaching 135 milliamperes at a filament current of 1.40 amperes.

When the plate voltage was dropped to 50 and the same variation of filament current carried out the plate current reached a value of only 48 milliamperes at $I_f = 1.40$ amperes. With plate voltages of 20 and 5 the

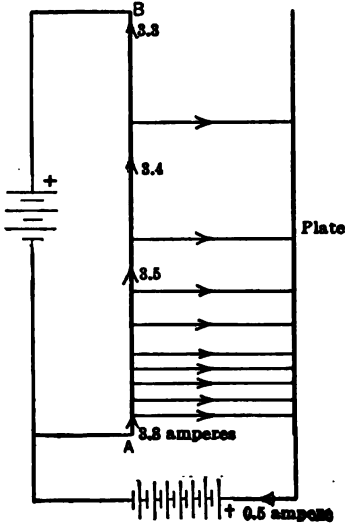

FIG. 14.—The emission of electrons from various parts of the same filament differs very much; because of the current to the plate, the filament current (hence filament temperature) is much greater at one end of the filament than at the other.

maximum plate currents were 10.6 milliamperes and 1 milliampere respectively. Now with $I_f = 1.40$ the emission is 135 milliamperes as shown in curve 1; with the plate at a positive potential of 5 volts (with respect to negative end of filament) only 1 milliampere was obtained, that is, only 1/135 of the electrons emitted by the filament reached the plate, the rest re-entering this filament *due to the space charge overcoming the comparatively weak field from the plate.*

Speaking in terms of the idea depicted in Fig. 10 we can say that the lines of force from the plate penetrated but a short way into the electron atmosphere; the great mass of the emitted electrons which, it must be remembered, stay very close to the filament, never feel the tractive effect of the positive plate. Those few having exceptionally high outward velocity (due to their velocity of emission and suitable collisions with the other electrons in the electron atmosphere) reach the outer regions of the atmosphere and so get attracted to the plate.

Even for the lower values of filament current (Fig. 15) the four values of plate voltage do not give the same plate current as might be expected. This is due to the fact that the IR drop in the filament is appreciable; in the special tube pictured in Fig. 13 all curves coincide in the lower parts.

In comparing the curves of Fig. 15 with those of Fig. 7 it is to be noticed that although they have the same general shape they have entirely different meanings. In Fig. 7 the flat parts of the curves indicate that saturation current has been obtained and in the lower curved portions the space charge is limiting the current; in Fig. 15 the lower curved por-

tions indicate that saturation current is flowing and the upper flat parts indicate that space charge is limiting the plate current.

The Three-electrode Tube.¹—The three-electrode tube differs from the two-electrode tube just analyzed in that a third electrode (called the *grid*, because of its ordinary form) is employed to control the plate current. In its normal form the grid is a metal mesh of some kind interposed between the plate and filament; the electrons passing from the filament to the plate have to go through the holes in the grid mesh and their passage to the plate is controlled to any desired extent by the potential of the grid with respect to the filament. In this form of tube therefore the plate current is controlled by three factors, the filament current, the grid potential and the plate potential.

The control electrode, or grid, in the ordinary form of tube as invented by DeForest, is inside the tube, directly in the path of the electrons traveling from filament to plate. It is possible, however, to use a control electrode outside the tube, although it seems as though this kind of control offers more difficulties

¹ Eccles has suggested the name "triode" for the three-electrode tube functioning by grid control of an electron stream.

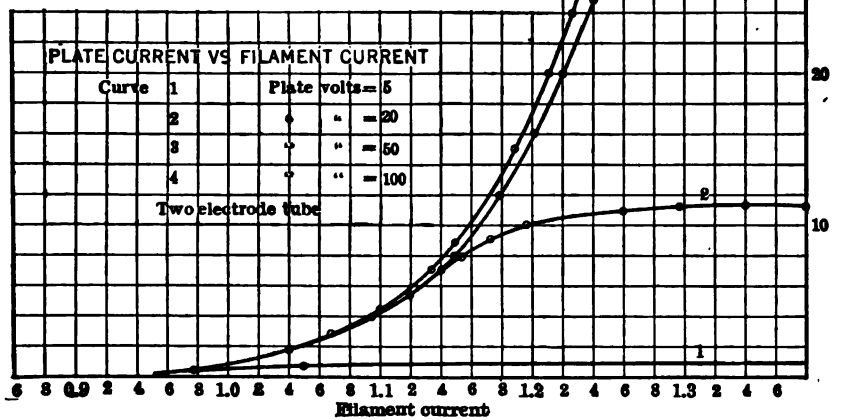

FIG. 15.—Variation of plate current in a kenotron as filament current is varied; for any one curve the plate voltage was held constant.

than the internal grid. In one type of outside grid tube tried by the author the control worked for a few seconds and then the accumulation of electrodes on the inside walls of the tube made it stop functioning. The inner walls of the glass must be made partially conducting to prevent this accumulation of charge.

The inside control electrode need not be placed between the filament and plate; it will work to some extent even if it is on the side of the filament opposite to that on which the plate is situated. Its action in such

a tube is not as efficient in controlling the plate current as in the normal placement; in the analyses to follow it will be supposed that the grid is inside the tube between the filament and plate and the curves given to illustrate the text will be records obtained from such tubes.

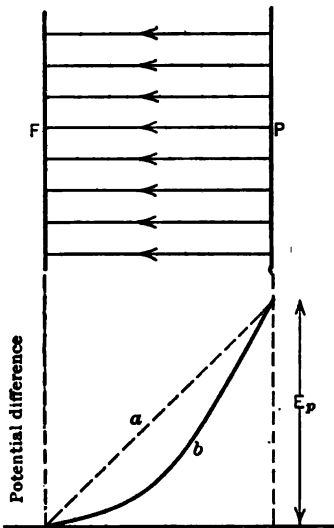

Fig. 16.—Two metal plates, one E_p volts higher potential than the other, have a uniform potential gradient between them, the potential being about as shown by dotted line *a*; if plate *F* is covered with an electron atmosphere the potential is changed to the form shown by line *b*.

Potential Distribution in the Three-electrode Tube.—The three-electrode tube functions because of the effect of the grid on the potential distribution between the filament and plate; it is therefore necessary to have a clear idea of this potential. In Fig. 16 is shown by the dotted line (*a*) this potential distribution between two metal plates, one marked *F* to represent the filament, the other marked *P* to represent the plate. The filament is supposed at zero potential and the plate at positive potential E_p . With a uniform field distribution as shown in the upper part of the figure the potential between plate and filament falls off uniformly. In the actual tube such a uniform potential gradient does not obtain; owing to the comparatively small surface of the

filament the potential falls more rapidly near the filament than near the plate.

If we now suppose an electron atmosphere to cover the surface of *F* the potential distribution is changed to some such form as indicated by the full line (*b*) in Fig. 16. The potential gradient becomes much lower in the vicinity of *F* because most of the field of *P* ends on electrons in the vicinity of *F* and so never reaches *F*; in fact if the emission is much greater than the plate current (practically always the case with three-electrode tubes in normal operation) the potential gradient very close

to the surface of F , due to the positively charged plate P is essentially zero. In Fig. 17 is represented a filament F , plate P , and grid G (shown in cross-section by the small circles) in the lower part of the figure is shown by the line marked (a) the potential distribution between P and F without any action from G , the curved form of this line is caused by the electron atmosphere around F . It must be remembered that most of the electrons emitted are very close to F and re-enter F without having moved very far toward G . The potential gradient in which the great majority of the electrons lie (close to F) is very small, hence they experience but little tractive effort from P .

If now G is made positive the potential distribution is changed to the line marked b in Fig. 17. The potential gradient between G and F has been much increased so that many of the electrons which previously fell back into the filament will now move toward G . Referring to the upper part of Fig. 17, electron a , which, without positive grid, would have fallen back into the filament, now moves toward G , and so is found in some such position as a' . In this position it experiences two attractions, one from G and one from P . Because of the relatively higher potential and larger surface of P most of the electrons which arrive at this position will move to the plate, instead of going to G as might be supposed.

There may arrive at position a' , however, an electron which has some velocity in the direction of G ; the result of this velocity and the two attractions from G and P may result in its going to G instead of P . Other electrons moving from F toward G may find themselves in such a position (with respect to the grid wires) as shown by b' ; these electrons will almost surely go to the grid instead of to the plate.

We may therefore conclude that the interposition of a positively charged grid between the filament and plate will partially neutralize the effect of the space charge; more of the electrons emitted from the filament will move away from it, some of them going to the grid and some going

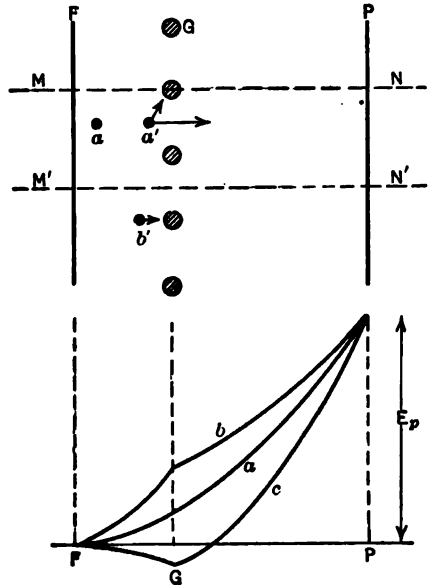

FIG. 17.—In a three-electrode tube the potential distribution between the filament and plate may be as shown by either b , a , or c , according to the potential of the grid.

to the plate. A positive grid then increases the plate current, plate potential remaining fixed.

A negatively charged grid will result in a potential distribution somewhat as shown by curve *c* of Fig. 17; if the grid is as negative as shown by the curve the plate current will be reduced to practically zero, because none of the electrons (except a very few which are emitted with exceptionally high velocity) can move against the negative potential gradient between *F* and *G*. It must be noticed of course that the potential curve on such a line as indicated by *M-N* (Fig. 17) will be different from that on such a line as *M'-N'*; the grid potential will not be so effective on the line *M'-N'* as on a line lying closer to one of the grid wires.

It will be appreciated at once that this effect of the grid in controlling the flow of electrons to the plate will depend on various features of construction of the tube.¹ The grid will exercise the most control when its wires are very fine and close together, and when it completely surrounds the filament. Unless the grid is considerably larger (in length and breadth) than the space occupied by the filament many of the electrons will go from the filament around the grid and thus arrive at the plate without having been subjected completely to the controlling action of the grid.

This idea is illustrated in Fig. 17*A*; the construction shown in *a* will permit the grid to exert a much greater control over the electron stream than will the construction shown in *b*.

¹ The question of the shielding action of a grid is taken up in Maxwell's "Electricity and Magnetism," Vol. 1; the case worked out is for a flat plate and flat filament, of infinite extent. In an article in Proc. I.R.E., Vol. 8, No.1, J. M. Miller shows how closely Maxwell's theory applies to the construction of an ordinary tube.

In an article published in Vol. 15, No. 4, of The Physical Review, R. W. King shows how the value of the controlling effect of the grid depends upon the parameters of the tube. The theoretical voltage amplification factor of the tube μ_0 (see p. 417 for significance of this constant) is shown to be expressible as

$$\mu_0 = \frac{2\pi an}{\log_e \frac{1}{2\pi rn}}$$

in which

a = distance between grid and plate;

n = number of grid wires per cm.;

r = radius of the grid wire.

In the derivation of the above formula the grid, hot filament surface, and plate have all been assumed as infinite parallel planes; although actual tubes depart very far from this requirement experimentally determined values of μ_0 for several tubes of widely different construction check with the calculated value quite well.

The interesting point in both Miller's and King's analyses is that the distance between the grid and filament plays no part in determining the value of μ_0 ; the closeness of the grid to the plate is apparently the controlling factor.

It is possible to build a hydraulic model of a three-electrode tube which illustrates very well the general ideas involved in the tube action. A jar (Fig. 18) (such as glass storage-battery container) has placed in the lower part a pipe *A*, closed at its two ends, which is full of small holes on its lower side and is connected to an air supply of very low pressure. A rubber sheet (such as the rubber used by dentists) is fastened to the side of this pipe *A* and also to a rod *C* in the upper part of the jar, horizontal and parallel to *A*. To make the model simple only one-half of the three-electrode tube is represented; a metal sheet *E* fastened to *A* makes all the air bubbles which escape move to the left (in Fig. 18) and so run up on the under side of the rubber sheet and escape past *C*. This stream of bubbles represents the electron stream from a fila-

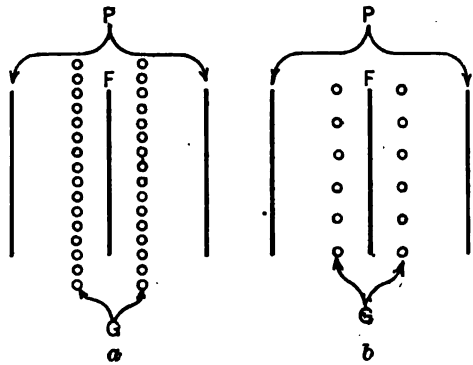

FIG. 17A.—The construction shown in *a* will give the grid *G* much greater controlling action than that shown in *b*; the more completely the grid encloses the filament and the finer its structure the greater will be its controlling action.

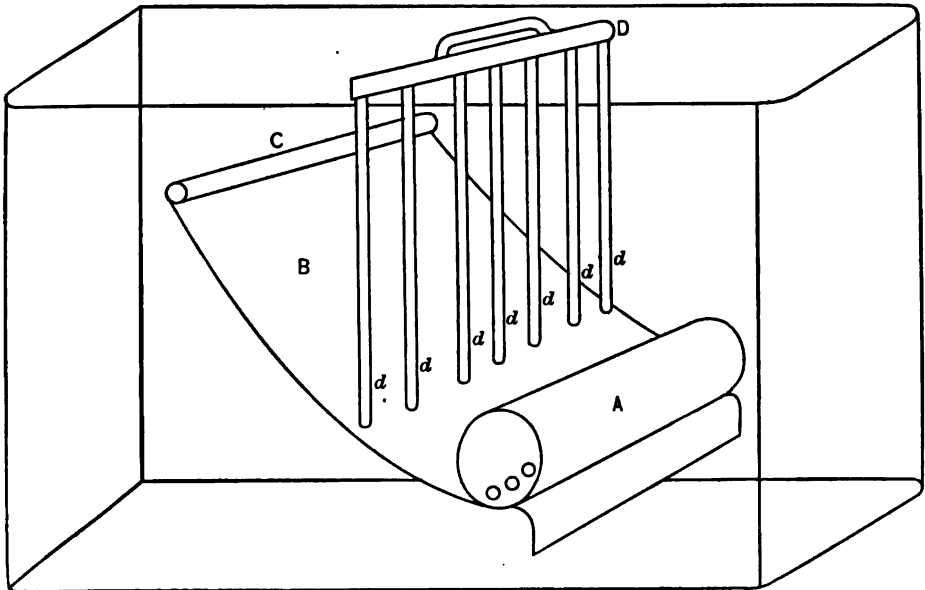

FIG. 18.—Hydraulic model of the three-electrode tube.

ment, *A* being the filament and *C* the plate, *C* being at higher level than *A*, as must be the potential of the plate with respect to that of the filament.

A stick *D* has several parallel wooden pins fastened to it and the lower ends of these pins are fastened (by tacks) to the rubber sheet close to pipe *A*, as shown. When *D* is moved up and down, the lower ends of its pins lift up and

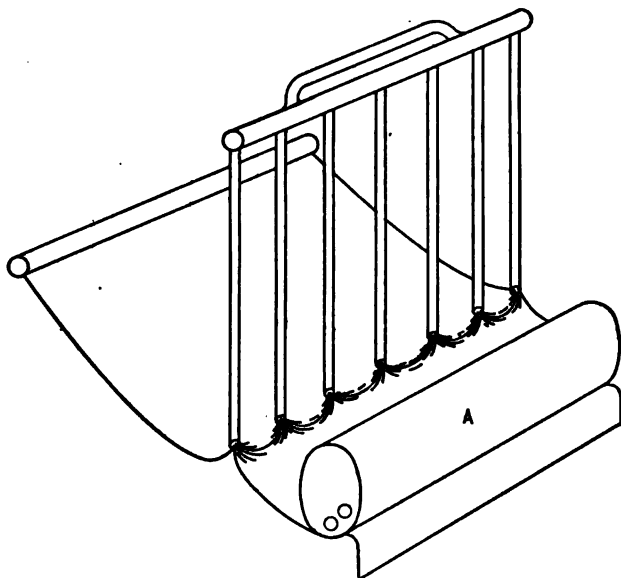

FIG. 19.—Hydraulic model of the three-electrode tube.

down those parts of the rubber sheets to which they are attached; in Fig. 19 is shown a sketch of the rubber sheet with the bar *D* lifted, and in Fig. 20 is shown the form of the rubber sheet when the bar *D* is depressed. If the pressure of the air in the pipe *A* is properly adjusted the flow of air bubbles up the underside of the rubber sheet resembles (more closely than any analogy the author has seen) the flow of electrons in a three-electrode tube.

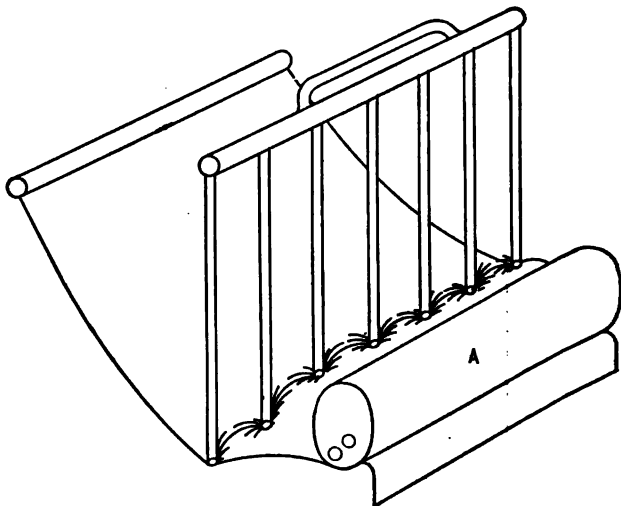

FIG. 20.—Hydraulic model of the three-electrode tube.

The action of the bar *D* with its attached pins, producing small hills and valleys in the rubber sheet, illustrates well the action of the grid.

The depression of the pins, making it more difficult for the air to pass up along the sheet, illustrates a negative grid, and when the pins are lifted up the increased flow of air corresponds to the increased plate current with positive grid.¹

The effect of the space charge is not simulated very well by the model; the accumulation of air between the "grid" (row of pins, *d, d, d*) acts to prevent other bubbles of air coming through the small holes in the "filament" (pipe *A*) but this action is not strictly analogous to the mutual repulsion of the electrons in the actual space charge effect.

Fields of Use of Three-electrode Tube.—Detector, Amplifier, Generator or Converter.—The three-electrode tube was first used as a detector of radio signals from spark stations; it was much more sensitive than its competitors, the magnetic detector, Fleming valve, etc., and so rapidly displaced these as a detector. In its original form as manufactured by DeForest a potential of about 30 volts was used on the plate; the normal plate current was a few hundred microamperes. Although these original tubes were rather erratic in their behavior, and not uniform in their characteristics (one tube not being like another) by careful adjustment of filament current and plate voltage, they were nearly as good detectors as the later types.

As the grid potential of a three-electrode tube controls the plate current (the power for which is supplied by a local battery) it is evidently applicable as a relay, the signal voltage controlling the delivery from the local power supply. When properly adjusted the grid circuit takes an extremely small power to operate, so that compared to the amount of power used in the grid circuit the amount controlled in the plate circuit may be thousands of times as great.

If the grid circuit is adjusted to take no power itself the power amplification is infinite; it must be remembered, however, that to operate the grid circuit certain coils, condensers, and resistances are required; taking the losses in these necessary associated circuits into account the power amplification is not infinite, but it is very large even then. Thus a certain tube used in telephone circuits as an amplifying repeater has a power amplification of about one thousand times.

If an alternating potential difference is impressed on the grid of a tube the plate current periodically increases and decreases. This pulsating current in the plate circuit may be made to produce fluctuations in the grid potential by means of a suitable transformer, the primary of which is connected in the plate circuit and the secondary connected between the fila-

¹ By having the pins, *d, d, etc.*, in the form of tubes open at their lower ends and having corresponding holes in the rubber sheet, some of the air bubbles will run up these tubes when handle *D* is lifted, thus imitating the action of the positive grid attracting some of the electrons, causing grid current.

ment and grid. If a suitable condenser is connected across either the primary or secondary winding to give a natural period to the circuit, the fluctuations in the plate current will be maintained by their action on the grid potential.

With this arrangement then the plate current fluctuates between certain maximum and minimum values, the voltage of the grid alternates, and in the condenser (no matter which circuit it is connected with) an alternating current flows. The device thus becomes a generator of alternating-current power; it might perhaps be more properly called a converter for changing continuous-current power into alternating-current power. The frequency of the alternating current is fixed by the L and C of the oscillatory circuit, and the amount of power available depends on the average value of the plate current and the voltage of the battery or generator supplying the current.

Small-power tubes using a plate potential of 300 volts and plate current of 40 milliamperes, giving about 4 watts of high-frequency power, were used extensively by the armies for radio signaling. Some of the larger-power tubes, used for higher-power sets, can generate 200 watts or more per tube; the generator furnishing the plate current impresses about 1500 volts on the plate and the electron current is about 0.3 ampere.

Various Types of Tubes.—According to the purposes for which they are to be used several different types of tubes have been evolved. Tubes designed for detecting high-frequency currents need to have a power output of only a very small fraction of a watt; they are generally fitted with small filaments, because but little emission is required and the voltage used in the plate circuit is low. Typical tubes use a filament current of 1.0 ampere at 4 volts and use a plate battery of 20 volts. Tubes used for amplifiers are more generally higher-plate voltage; perhaps 100 or 150 volts; the size of filament is about the same as used for a detector tube. Tubes used for generating power are designed for higher-plate voltage, from 300 to 2500 volts; as the amount of power available depends upon the value of plate current and this in turn upon the emission, the filament is much larger than in the amplifier and detector tubes. A 4-watt tube (output) might require a filament current of 1.5 amperes at 10 volts; a 200-watt tube might require 3.7 amperes at 20 volts. Later a tabulated list of ratings for various tubes will be given.

The grids used vary from a very fine mesh of the finest tungsten wire obtainable (wound 40 per cm.) to a lattice work of comparatively coarse wire spaced about 3 per cm. The grid may be flat or cylindrical according to the form of tube.

The plates used are of various forms; they vary from a short zig-zag shaped tungsten wire perhaps 5 cm. long, or a small thimble about 0.5 cm. in diameter and 0.5 cm. long to two heavy plates about 5 cm. square.

The material used for the grids and plates is generally nickel or tungsten, or molybdenum; the tubes designed for generating much power are likely to have all metal parts, filament, grid, and plate of tungsten.

In Fig. 21 are shown some of the more common tubes; *A* and *B* are power tubes of 50- and 250-watt ratings, respectively; *C* and *D* are small-power tubes designed for an alternating-current output of about 4 watts, *E*, *F* and *G* serve as either detectors or amplifiers; *H* is a Deforest audion of the original type, *I* is a cylindrical tube made for amateur use; *J* is a modern Marconi tube; *K* and *L* are two amplifying bulbs, the latter having extremely fine grid and very small plate (a nearly invisible zig-zag wire); *M* is a special power tube with grid brought out at tip of the



FIG. 21.—Various types of tubes used in getting the experimental data given in this chapter.

bulb. The former tubes are all of American manufacture; at *N* is shown an English power tube, at *O* a special French amplifier bulb and at *P* a small English detector and amplifier tube. At *Q* is shown a special type of tube called a dynatron, explained on page 534.

In most of the smaller tubes the glass bulb is fitted with a brass collar by which they are held in a suitable socket; the socket is equipped with four flexible contacts which press against four pins projecting from the base of the bulb. These four pins connect to the filament, grid, and plate.

Limits of Operation of a Tube.—There are in general two limiting factors in the use of a vacuum tube—overheating and consequent collapse of the parts or of the bulb itself, and ionization of the residual gas in the tube. It is impossible to completely evacuate a tube so that some

gas is always present; if too high a plate potential is impressed or too high a filament current (with fairly high plate voltage) is used this residual gas will ionize and thereby change the operating characteristics of the tube by an amount depending upon the amount of gas present.

With a tungsten filament tube the evacuation process is carried out more thoroughly than with the oxide coated filament so that destructive ionization is not likely. The limit of the tungsten tubes (aside from the prescribed limit for filament current) is the safe heating of the plate and grid, generally the plate, because the grid circuit is so adjusted that the grid takes but little current. This heating is due to the power, used in accelerating the electrons as they move from the filament to the plate, being given up when the electrons are stopped by hitting the plate; the phenomenon is called *electron bombardment*. The amount of power so used on the plate is equal to the product of the plate voltage and the plate current; if this product varies cyclically (as it actually does when the tube is being used for power converter), its average value must be taken in calculating the amount of power used in bombarding the plate.¹

The safe power to be used in bombarding the grid is much less than that for the plate, for two reasons; the surface of the grid is generally much smaller than that of the plate, and the possibility of heat radiation from the grid is less than that of the plate.

The large tube shown at *A*, Fig. 21, has a rating, for example, of 250 watts plate and 25 watts grid. Thus a plate current of 0.25 ampere (steady value) would be permissible with a plate voltage of 1000 volts, and with this amount of power used in the tube the plate becomes quite a bright-red color. The two tubes shown at *B* and *D* have a safe plate capacity of 12 watts; with a plate voltage of 300 (their rated value) the average plate current should not exceed 40 milliamperes.

The other tubes shown at *E*, *F*, *G*, *H* and *I*, etc., are never so operated that heating is the limiting factor; they are designed to be used in certain circuits, and if the filament current or plate voltage are far from their rated values it is likely that the tubes will not function efficiently.

Effect of Gas in a Vacuum Tube.—Ionization.—The modern vacuum tube is a true electron relay; it functions entirely by means of the stream of electrons emitted from the filament, and these electrons in motion constitute the only current in the tube. This ideal is not quite realized by any vacuum tube, but it is so nearly approached that whatever other current may exist is so small as to make its effect negligible when considering the action of the tube.

The earlier types of vacuum tubes (Fleming valves and Deforest audions) were not at all well evacuated in the light of modern practice;

¹ A bombardment equivalent to 10 watts per sq. cm. of plate will bring its temperature to about 1300° C.; such a temperature gives the plates a fairly bright-red color.

there was a deal of gas left in the bulb at the completion of the evacuation process and this gas made the tubes very erratic and undependable in their behavior.¹ Not only would various bulbs, supposedly similar, have very different characteristics, but any one bulb would not act consistently, and many tricks had to be employed to make the bulbs perform to the best advantage.

An exact study of the effect of gas in a vacuum tube cannot be given here; only those points which bear directly on the operation of the tube in radio practice will be outlined. The student is referred to some such book as Thomson's "Conduction of Electricity through Gases" for a deeper analysis than will be attempted here.

A cold electrode in a vacuum tube, unless subjected to considerable electron bombardment, will not give off electrons in appreciable quantities; thus in a two-electrode tube if the plate is made negative with respect to the filament no current will flow, because if the plate is made negative any current which flows from plate to filament must be caused by electrons leaving the cold plate. Experiment demonstrates the truth of this statement; if other possible carriers of current are eliminated (such as actual leaks inside or outside the tube, or gas inside the tube) the amount of current which will flow is too small to be measured. We may safely conclude that when a cold electrode (either grid or plate) of a tube shows current in such direction as to indicate electrons flowing from it, inside the tube, the tube has in it gas which is serving as a conductor of current.² This statement neglects the possibility of secondary emission of electrons due to excessive bombardment by electrons coming from the filament; this effect will be treated in a later paragraph.

Ordinarily a gas is a good insulator and will not carry current, but when under rather low pressure it may be made to carry very large current if by some means it becomes *ionized*. By this term is meant the breaking up of the normal gas atom into two parts, a free electron and positively charged nucleus; this breaking up of a gas atom corresponds to the "break-down" of any ordinary insulator when it is subjected to too high a potential gradient.

In a Geissler tube the gas becomes ionized (showing the well-known blue glow) only when rather high potentials are used, generally several thousand volts. Now in the vacuum tube used for radio such high voltage

¹ It is quite evident, however, that Fleming appreciated the necessity of a high vacuum to make the tubes constant in behavior; the superiority of present evacuation is due not so much to any conception of its importance, perhaps, as to the better pumps now available.

² It must be remembered that even with the highest vacuum obtainable there is still a tremendous number of gas molecules in the evacuated space; it is likely that in highest vacuum tubes used to-day (10^{-6} mm. of mercury) there are of the order of 10^8 gas molecules per cubic centimeter.

is practically never used; ionization of the gas in the tube may occur with voltages as low as thirty or forty. This is due to the fact that the hot filament furnishes the electrons which by their motion (caused by the positive plate potential) serve to start the ionization of the gas atoms. In a Geissler tube no such means is at hand for starting the ionization, hence the comparatively high voltage required to show the effect.

The role played by the electrons emitted from the filament in producing ionization is easily shown by a simple test. If a tube which is known to be faulty is subjected to normal plate potential with cold filament, no plate current will flow and the tube will show no signs of ionization. Now if the filament current is gradually increased emission of electrons will commence and a slight plate current will flow; at a certain filament temperature, depending upon how much gas there is in the tube, the familiar blue haze will appear in the bulb, accompanied generally by a very large increase in the plate current, thus showing that the filament must be emitting a certain minimum number of electrons before appreciable ionization of the gas occurs.

If but a small amount of gas is present the pale blue glow may be so weak as to be invisible, but the presence of appreciable quantity of gas is always shown by erratic changes in the plate current.

Some oxide-coated power tubes show a bright fluorescence on the plate when being used, generally in the form of a pattern of the grid. It is easy to mistake this effect for ionization because of the blue color from the fluorescing plate; if the plate is hidden from the eye (by the hand or a piece of cardboard) it will be seen that there is no blue glow in the space inside the tube. The intensity of the effect of fluorescence depends upon the condition of the surface of the plate, which is generally covered with more or less oxide.

Danger to a Tube from Ionization.—When a tube ionizes the consequences resulting depend upon the type of tube being used and upon how quickly the condition is removed. In the case of a detecting tube, or amplifying tube, the state of ionization will generally stop the functioning of the tube, its characteristics being entirely different when the tube is filled with a semi-conductor (the ionized gas) than those of a normal electron tube. If either the plate voltage or filament current is reduced the ionization will disappear and the tube may operate as well (or possibly better) than it did before ionizing.

In the case of a power tube the situation is different; unless either the filament current or plate potential is immediately reduced the tube may be completely spoiled. Ionization practically never occurs in a tungsten tube because of the high degree of vacuum ordinarily used; the oxide filament tube is much more likely to suffer from it. In these tubes there is always a lot of gas in the metal parts of the tube, filament, grid, and

plate; now when ionization starts the electrons of the ionized gas travel to the plate, it being positive, but the positive nuclei travel to the filament and subject it to a bombardment.

This bombardment results in extra heating of the filament, generally in one spot, which extra heating tends to aggravate itself and burn the filament out at this point. The hotter the filament the greater the electron emission, and also gas is likely to be emitted from the filament at this hot spot; where the gas and electron emission both increase the ionization increases, increasing the bombardment of the filament at this spot, and thus by the cumulative action burning it out. At the time the filament burns out it releases a lot of gas which, becoming ionized, may permit the passage of such a large current from the plate as to result in a miniature "explosion" inside the tube, completely wrecking the parts and breaking the bulb.

When a power bulb with oxide filament once ionizes it is practically valueless¹ until re-exhausted; the ionization itself will probably result in the emission of extra gas from the bombarded parts, so that the tube has more gas in it after ionization than before.

Evacuation of a Vacuum Tube.—Because of the deleterious effects of gas the electron tube must be very carefully freed from any appreciable quantity of it. With modern pumps the getting out of the gas from the *space* inside the bulb is very simple and rapid but this is not sufficient. Metals, oxides, and glass absorb a deal of gas which gradually comes out; so that a tube pumped "clean" will soon show gas because of its emission from the parts of the tube. This emission is very slow at ordinary temperatures, so that a tube might be pumped a long time without getting sufficient gas from the parts to prevent further emission. If, however, the glass and metal parts are heated, the gas is expelled from them very rapidly, and this is the scheme used in evacuating tubes; the whole tube is subjected to a "baking" process while connected to the pumps.

This heating should be carried much higher than any temperature at which the tube may operate; thus if in practice the plates and filament operate at dull-red heat they should be run for several minutes at a bright-red heat during evacuation. This overheating of the parts is regularly done with tungsten tubes but it cannot be carried out to the same degree with the oxide-coated filaments. The coated filament is easily spoiled if subjected to too high a temperature, and this limits the possibility of complete evacuation. For this reason, as previously mentioned, the oxide-coated power tubes are much more subject to destructive ionization during operation than are the tungsten tubes.

¹ It may be used, however, for generating a small amount of power, providing the plate voltage is kept sufficiently low; thus a 300-volt tube which has ionized badly may sometimes be used by reducing the plate voltage to perhaps 250.

Detection of Gas in a Three-electrode Tube.—In Fig. 22 is shown a set of curves from a detector tube, illustrating the effect of filament temperature on the tendency of the tube to ionize. With .40 ampere and

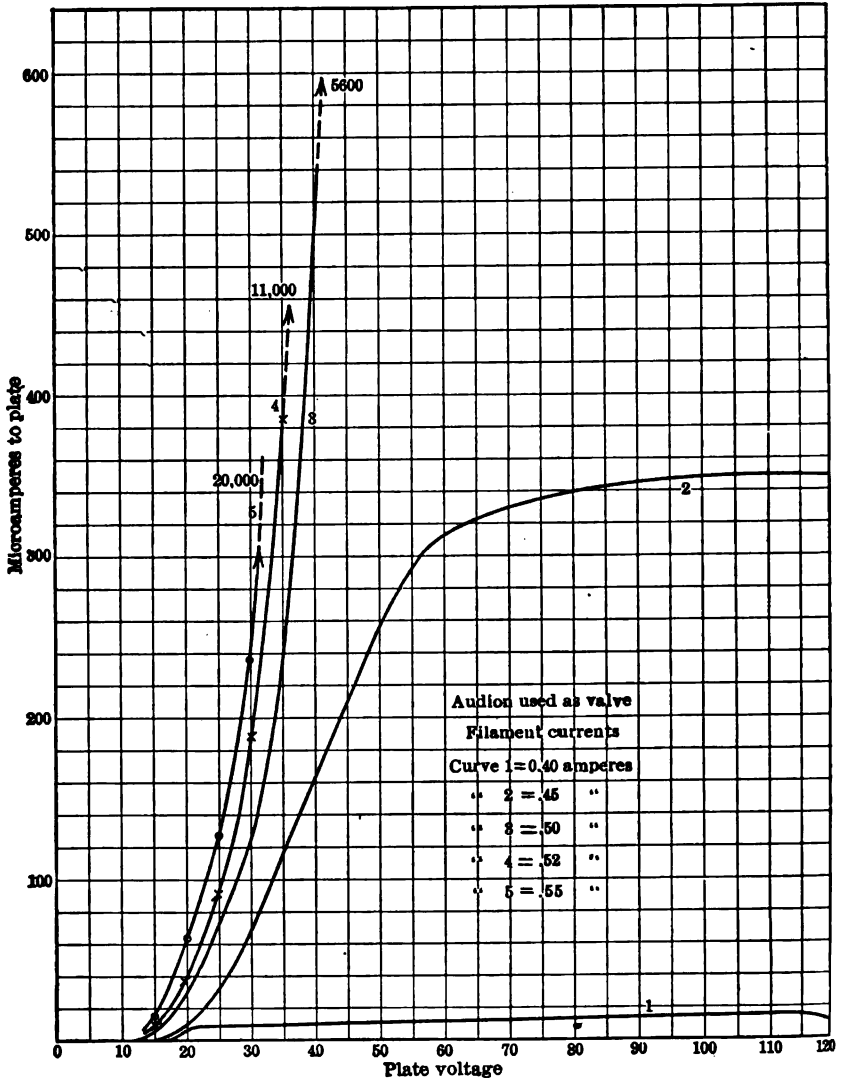

FIG. 22.—Plate current of a tube containing gas, showing effect of ionization.

.45 ampere in the filament the tube would not ionize (at least not to such an extent as to show itself); with .50 ampere ionization started with the plate voltage at 40 and the current at once jumped to ten times its value. This increase was due to two distinct actions; first, the pres-

ence of the ionized gas reduced the limiting action of the space charge to practically zero, thus permitting the plate current to increase at once to the value fixed by the emission from the filament; second, the ionized

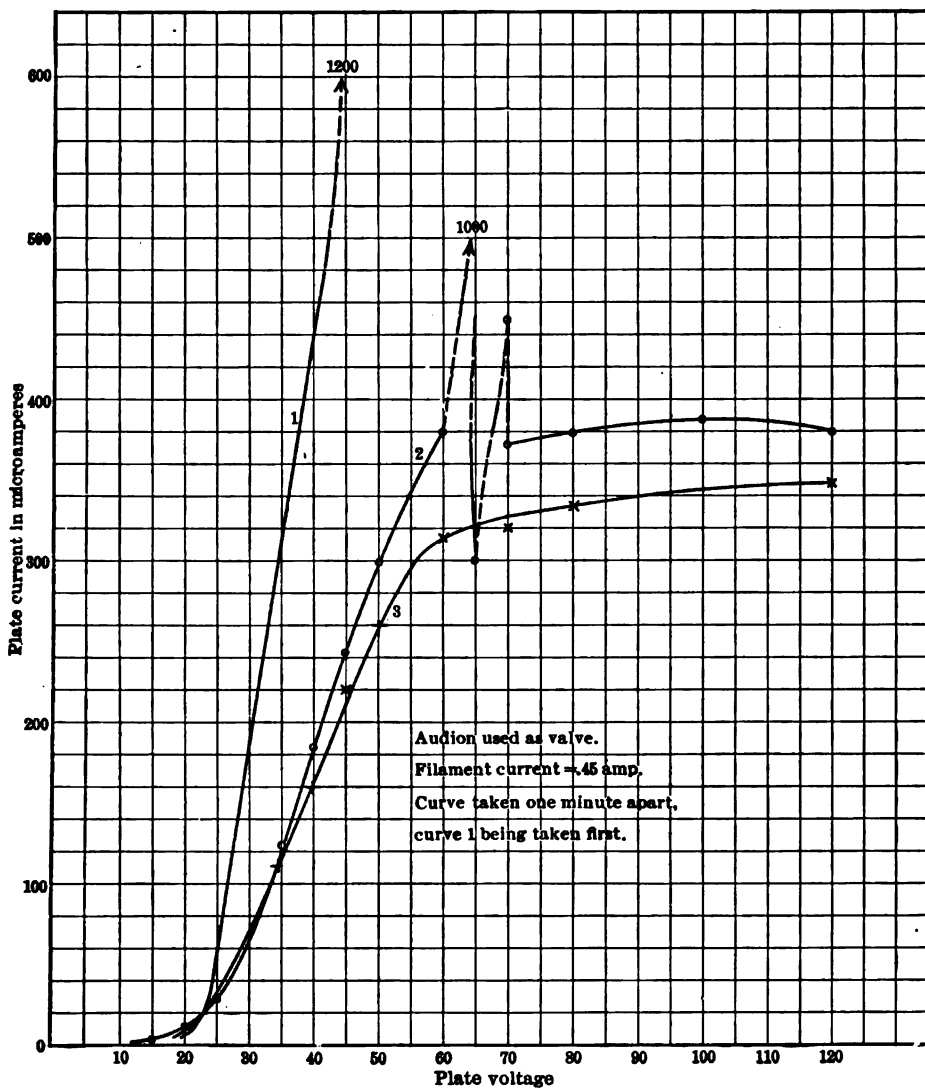

FIG. 23.—Disappearance of gas from a tube; curves were taken in the order 1-2-3; ionization showed on the first curve, to a lesser extent in the second and not at all in the third.

gas acts as a conductor, giving a current in addition to that afforded by the emission from the filament. With higher filament currents the ionization set in at lower voltages as indicated on the curve sheet.

In Fig. 23 are shown three curves from the same tube, one taken after the other. Curve 1 was taken first; ionization set in with a plate potential of 40 volts, causing a large increase in plate current, which value was maintained for one minute. The plate voltage was then reduced to zero and again increased, and with same filament current as before; ionization set in at 60 volts, indicating that during the maintenance of the ionization current previously, some of the gas had been occluded in the glass walls of the tube or elsewhere. This idea is substantiated by the fact that when ionization did set in (somewhat above 60 volts) the current jumped

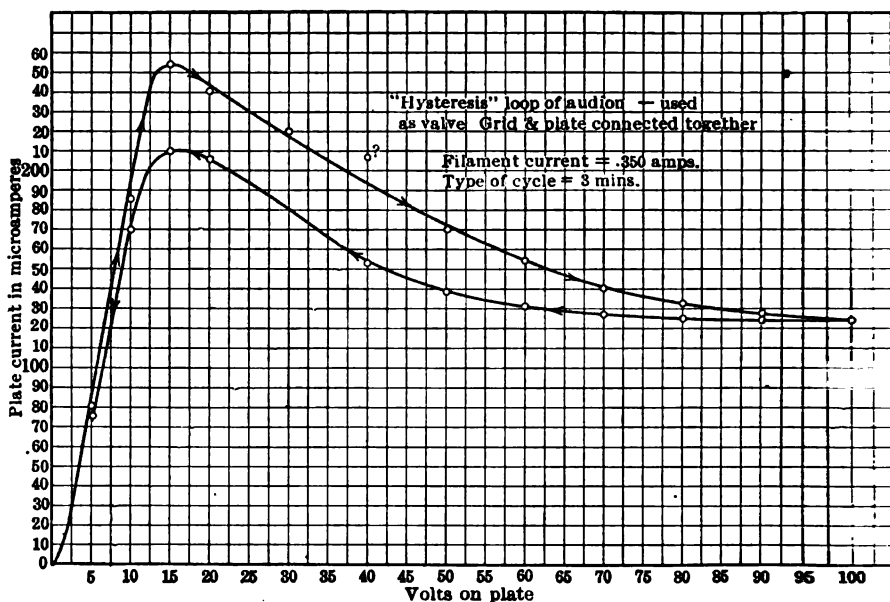

Fig. 24.—In this tube the effect of the gas present was to so alter the emitting properties of the filament that the saturation current was appreciably different with increasing and decreasing plate voltages, showing probably change in emissivity of the filament.

to only 1000 microamperes, whereas previously it had gone to 1200 microamperes. In a short time the ionization ceased, as indicated by disappearance of the blue haze and decrease in plate current to an even lower value at 56 volts than it had at 60 volts before ionizing. Upon again increasing the voltage the current followed the values shown. Upon dropping the plate voltage once more to zero and going through the same range as before the plate current varied as shown by curve 3, no ionization at all occurred. This action is quite typical of tungsten filament tubes; they tend to clean themselves of any gas present in the bulb.

In Fig. 24 is shown a peculiarity of a tube having a small amount of

gas present; a kind of "hysteresis" cycle occurs, the current not going through the same values for decreasing plate voltage as for increasing plate voltage. At voltages higher than fifteen this tube showed a drooping current-voltage curve, which means that its a.c. resistance (for limited values of impressed alternating e.m.f.) is negative; as long as it held this

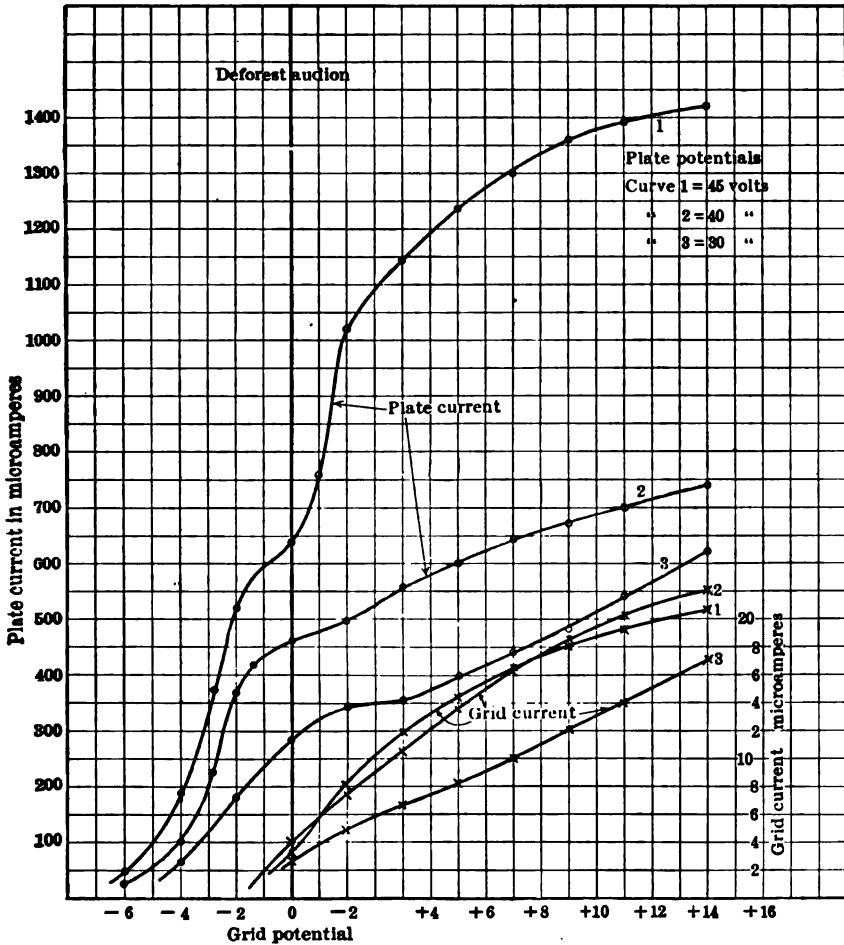

FIG. 25.—A small amount of gas in a three-electrode tube may produce more or less regular "humps" in the plate current curve.

characteristic, this tube might be used as a two-electrode tube for producing oscillations, its operation being the same as that of a Dudell singing arc.

The normal variation between plate current and grid voltage in a three-electrode tube gives smooth curves, but if gas is present abnormal

shapes may be obtained. Fig. 25 shows an effect of this kind and for each of the plate voltages used a "hump" occurs in the plate current curve.

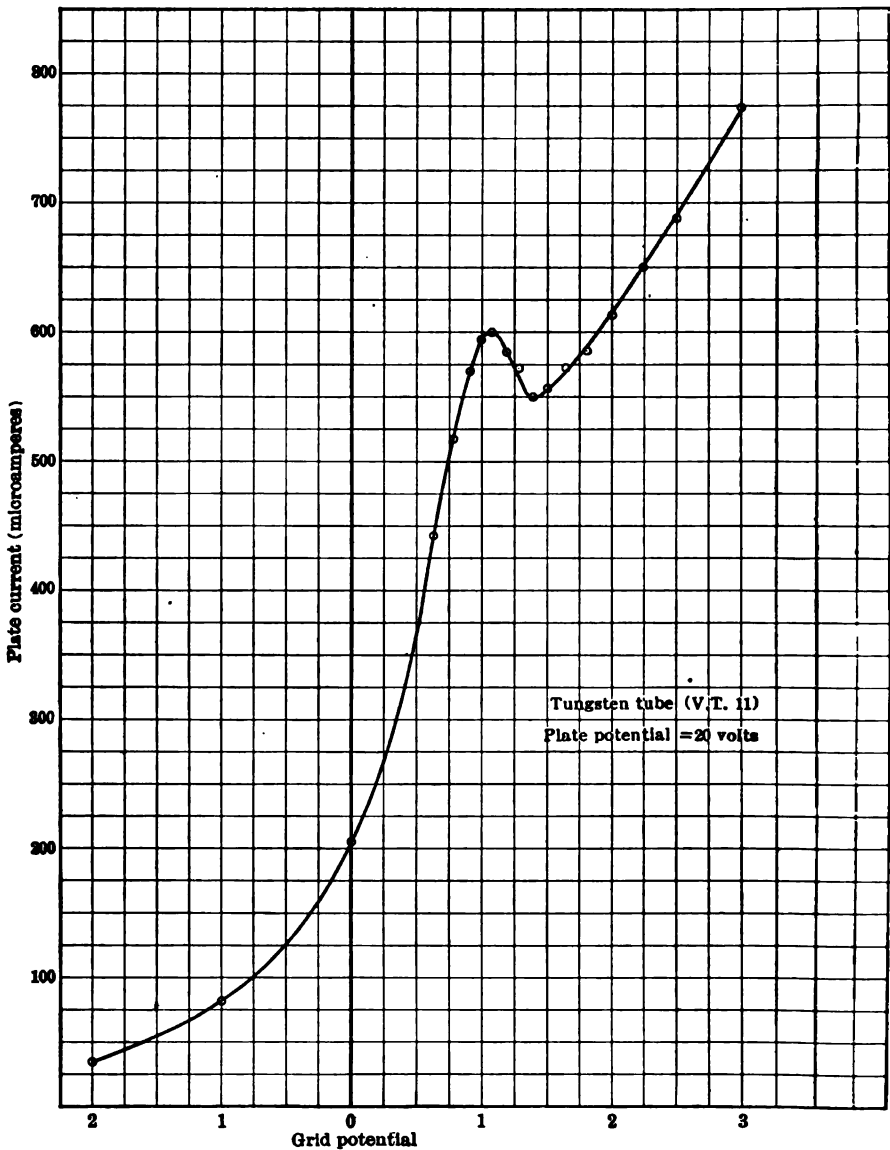

FIG. 25A.—Showing the effect of a small amount of gas in producing a well-defined "hump" in the plate current curve.

The position of this hump shifts to different grid voltage for the different plate voltages used in the test.

In Fig. 25A is shown a more striking example of this same peculiarity. The curve is for a well-pumped modern tube using tungsten filament; it is undoubtedly due to the presence of mercury vapor in the tube. If a mercury vapor pump is used for evacuation, some of the mercury vapor will be left in the tube unless a proper freezing trap is used. If a tube showing this effect is used for a detector of radio signals it is remarkably sensitive if adjusted to just the right grid potential by a suitable potentiometer.¹

If a tube is completely freed from gas the current to the grid will not reverse when the potential of the grid is made negative. Even in a very well pumped tube, however, there is a slight reversed current to the grid when the grid is negative, caused by the positive ions of gas in the tube. This grid current depends upon the gas present being ionized by the electron flow to the plate and is zero if the electron flow is zero. The more plate current there is the more is the gas ionized and hence the greater is the grid current.

The effect is shown in Fig. 26, which shows the grid current in a well pumped tungsten tube;

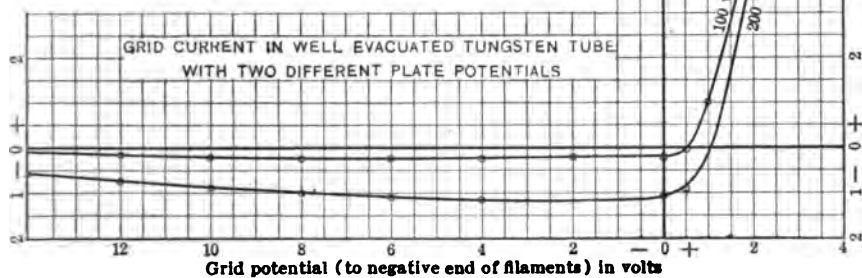

FIG. 26.—Even in the very high vacuum tubes the grid shows a reversed current when its potential is negative; these curves are for a type *P* plotron having a high degree of evacuation.

it is seen that for plate voltage of 100 the reversed grid current is much less than it is for a plate voltage of 200; this is due to the lower plate current at the lower plate voltage producing less intense ionization

¹ It must be remembered that when the grid is subjected to *very high frequency variations* in its potential it is quite likely that the plate current does not vary in the manner indicated by the curve obtained in direct current test, such as that given in Fig. 25A.

of the gas present. As the grid potential was increased (in the negative direction) the grid current decreased instead of increasing as might be expected. This is due to the decrease of plate current with the lower grid potentials.

A tube having considerable gas in it may be made extremely sensitive as a detector if adjusted with a plate or grid voltage nearly sufficient to produce ionization; the slight increase in grid potential due to the incoming signal may then cause ionization to occur with a resultant great increase in the plate current. Such tubes are not reliable enough to be of any great practical importance, however; the modern high-vacuum tube if properly connected in cascade with the others, may produce the same amount of amplification and at the same time have the necessary reliability of action.

Tungsten Filaments and Oxide-coated Filament.—As noted in the first paragraph of this chapter, a pure metal such as tungsten must operate at a very high temperature before an appreciable emission of electrons takes place; to get the amount of emission required for a power tube the tungsten must be at a dazzling white heat. In first operating tubes of this type the experimenter will get an incorrect idea of their behavior unless meters are used, and the filament is run right up to its rated current.

Tubes using a Wehnelt cathode, or oxide-coated filament, on the other hand, must not be operated at a high temperature or they will be spoiled. These filaments are made of thin platinum strip, coated with a mixture of various oxides (barium, strontium, and calcium) together with a suitable cement; in order to make the oxide coating adhere more tenaciously the platinum strip is generally twisted about itself. These filaments should never be operated at a temperature higher than that required to give a bright cherry-red color; the detector and amplifier bulbs generally operate satisfactorily at a much lower temperature than this.

To get the same emission from a tungsten filament as from an oxide-coated filament requires about twice the amount of power; where the cost or difficulty of obtaining power is of prime importance, therefore, the oxide-coated tube is superior. For detector and amplifier tubes used in army field work for "standby" service, being in continued use, this question of power supply is of more importance almost than any other; the power for heating the filaments must be transported generally in the form of portable storage batteries and that tube requiring the fewest renewals of batteries is the best, even though some of its other characteristics may not be as good.

Power tubes, on the other hand, use a considerable amount of power in their plate circuits, as much or more than that used for heating the filament so that the filament power does not have the same relative importance as it does for the detector and amplifier bulbs in which the filament

requires perhaps 3 watts for heating, whereas the plate circuit requires but .01 watt. So far as power consumption of the tube is concerned, therefore, the lower filament power of the oxide tube does not offer such great advantage, in fact, it seems to the author that the oxide filament is not the equal of the tungsten filament for power tubes. The vacuum attained in oxide filament tubes is never as good, or as permanent, as that commonly used with tungsten filaments, and this fact leads to their very frequent failure. The gas present ionizes and this ionization (if there is appreciable gas present) completely spoils their operation as generators. It sometimes happens that a tube ionizes, due to excessive potential gradients, and when the high plate voltage is removed, the tube acts as well as before, but, on the other hand, the result of the ionization frequently results in a burnt-out filament and completely spoiled tube.

With a tungsten tube, on the other hand, even if ionization occurs, the effect will soon disappear if the plate voltage is held up to its normal value; the effect of the exceedingly hot tungsten filament is to use up, in some way or other, the gas causing the ionization. In such a tube the vacuum is likely to improve the more the tube is used.

Characteristic Curves for Three-electrode Tubes.—The so-called "static" characteristic curves of a three-electrode tube show how the plate current and grid current vary as the grid potential is varied over a sufficient range to cause this plate current to vary from its maximum operating value to zero, the plate potential being constant while the series of points for the curve is being obtained. The same curves are taken for several values of plate potential.

Another set of curves is sometimes used showing the variation of plate and grid currents as the plate potential is varied from zero to its maximum safe value, the grid potential remaining constant, a series of such curves is obtained for various grid potentials.

Another, and probably more useful, set of curves show how the plate and grid currents vary as the grid potential is varied, the plate potential varying, during the process of getting the curve, in the same way it does when the tube is actually used in a detecting or generating circuit. When being used the three-electrode tube always has an impedance of some kind in series with the plate circuit. The value of the voltage used in the plate circuit is constant, not varying as the grid potential is varied, by signal or otherwise; it is therefore evident that as the grid potential varies, thus varying the current in the plate circuit, the plate potential must vary because it is equal to the plate circuit voltage minus the drop in the series impedance, and this drop varies with the grid potential.

This last set of curves is the one which most readily permits the prediction of the behavior of the tube. A resistance should be put in the plate circuit equal to that which is used when the tube is actually operating;

a plate circuit voltage should be used such that when the grid is set at the same potential as its average potential under operating conditions the plate current is the same as its average operating value. The plate-circuit voltage is frequently called the "B" battery voltage.

It has become customary in speaking of grid potential to refer the grid to the *negative end of the filament*; unless otherwise stated all the curves shown in this text are so given. In case the characteristics are desired when the grid is connected to the positive end of the filament it is only

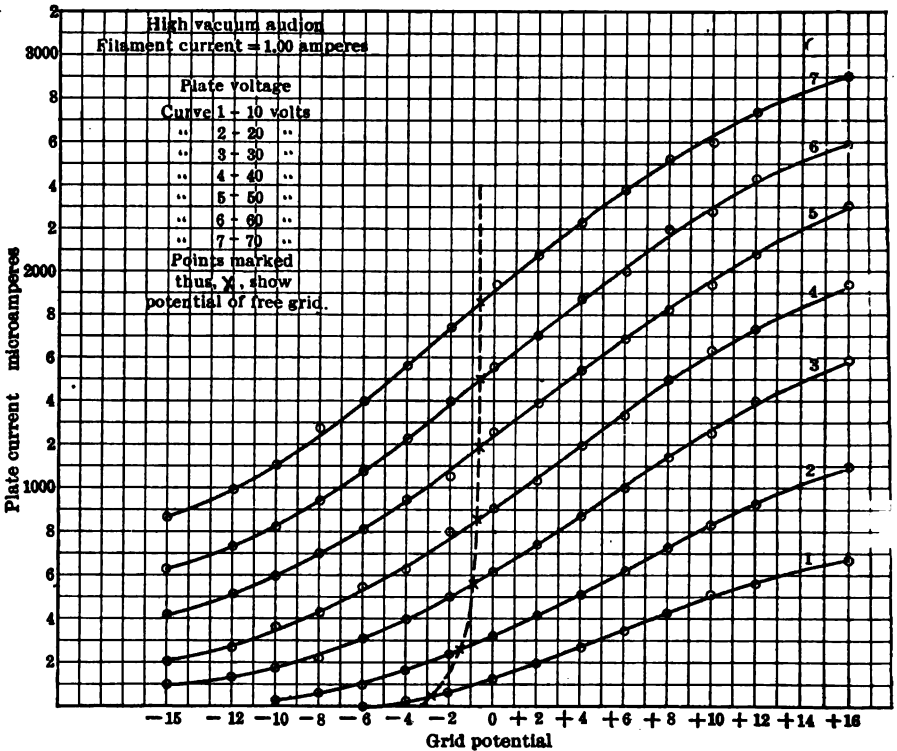

FIG. 27.—An old Deforest audion, after being well evacuated and baked, showed just as regular characteristics as the modern tube.

necessary to move the "zero grid potential" along, on the curve sheets as given, by an amount equal to the IR drop in the filament.

In Fig. 27 is shown a set of plate-current curves from an old Deforest audion, after it had been re-evacuated to take off all possible gas. The plate circuit had no added resistance except that of the B battery, which was so low that the variation in plate current did not appreciably affect the plate potential. On the curve sheet is shown the locus of the "free grid potential," i.e., the potential at which the grid set itself when its

external terminal was completely insulated. This point will be taken up more in detail later.

For the tube used in getting the curves of Fig. 27 it will be noticed that the grid voltage was more effective (in controlling the plate current) than the plate voltage in the ratio of about two to one. Thus to get 1 milliampere of plate current it is necessary to use either ($E_p=20$, $E_g=13$), ($E_p=30$, $E_g=5.6$), ($E_p=40$, $E_g=1$), ($E_p=50$, $E_g=-3.4$), ($E_p=60$, $E_g=-7.2$) or ($E_p=70$, $E_g=-12$). Using the two extreme values, we see that a decrease in plate potential of $(70-20)=50$ volts is neutralized (in so far as it affects plate current) if the grid potential is increased from -12 volts to $+13$ volts, or a change of 25 volts.

In Fig. 28 is shown a set of curves from a tube designed for amplifying purposes; free grid potentials in this tube follow about the same changes as for the tube used in Fig. 27. The much greater control of the grid of the tube is seen from the values of plate voltage and grid voltage for a current of .001 ampere. This is obtained with either ($E_p=160$, $E_g=.2$), or ($E_p=70$, $E_g=2.6$) so that an increase in grid potential of 2.4 volts offsets a decrease in plate potential of 90 volts; the effectiveness of the grid is thus thirty-eight times as great as that of the plate.

In Fig. 29 is shown a set of curves for a tube having the plate and grid very close to the filament, the grid being comparatively coarse compared to that of the tube of Fig. 28. In Fig. 29 the grid potentials are referred to the positive end of the filament; as the filament IR drop was about 3 volts it is seen that if the grid were connected to the negative end of the filament the grid current would be practically zero. This tube is generally used as a detector with the grid normally somewhat positive.

It will be noticed that the grid current (for a given grid potential) decreases as the plate potential is increased. When the grid and plate are positive by about the same amount (curves D and D' with grid 3 volts positive) each takes about the same thermionic current; the greater area of the plate compensates for the greater proximity of the grid and filament.

Fig. 30 shows the effect of filament current on the static characteristics of a large power tube (G. E. plotron type $P-10$, the 10 signifying the number of grid wires per inch). The grid currents with negative grid potentials are too small to be plotted on the curve sheet. The filament currents were measured at that end carrying the smaller current.

As was pointed out in Fig. 14, the current in a filament varies throughout its length when it is delivering electrons to the plate, the amount of variation depending directly on the value of the plate current. In Fig. 31 is shown a set of curves to illustrate this point; a constant voltage of 32 was impressed on the filament, the grid was held at a positive potential of $+100$ volts and the plate voltage varied from zero to 200 volts. This set of curves serves not only to show the peculiar changes in filament

current, but also how, as the plate voltage increases, the grid current is reduced. The sum of the grid current and plate current gives, for all values of plate voltage, the difference between the two filament currents. The resistance of the filament of a vacuum tube under such conditions is

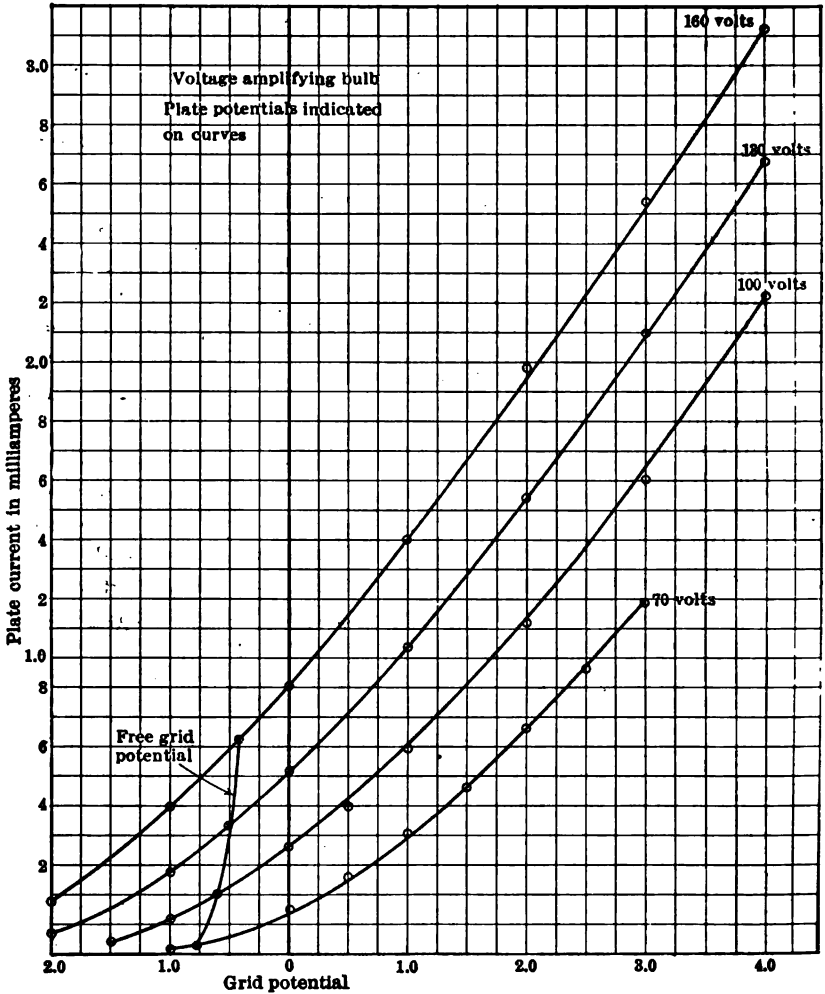

FIG. 28.—Plate current curves for a tube intended as a voltage amplifier.

not a simple function of volts and amperes; it involves all the theory of a long, leaky, telegraph line.

The safe filament current for these large power tubes is always rated in terms of the maximum current, that is, the end of the filament where

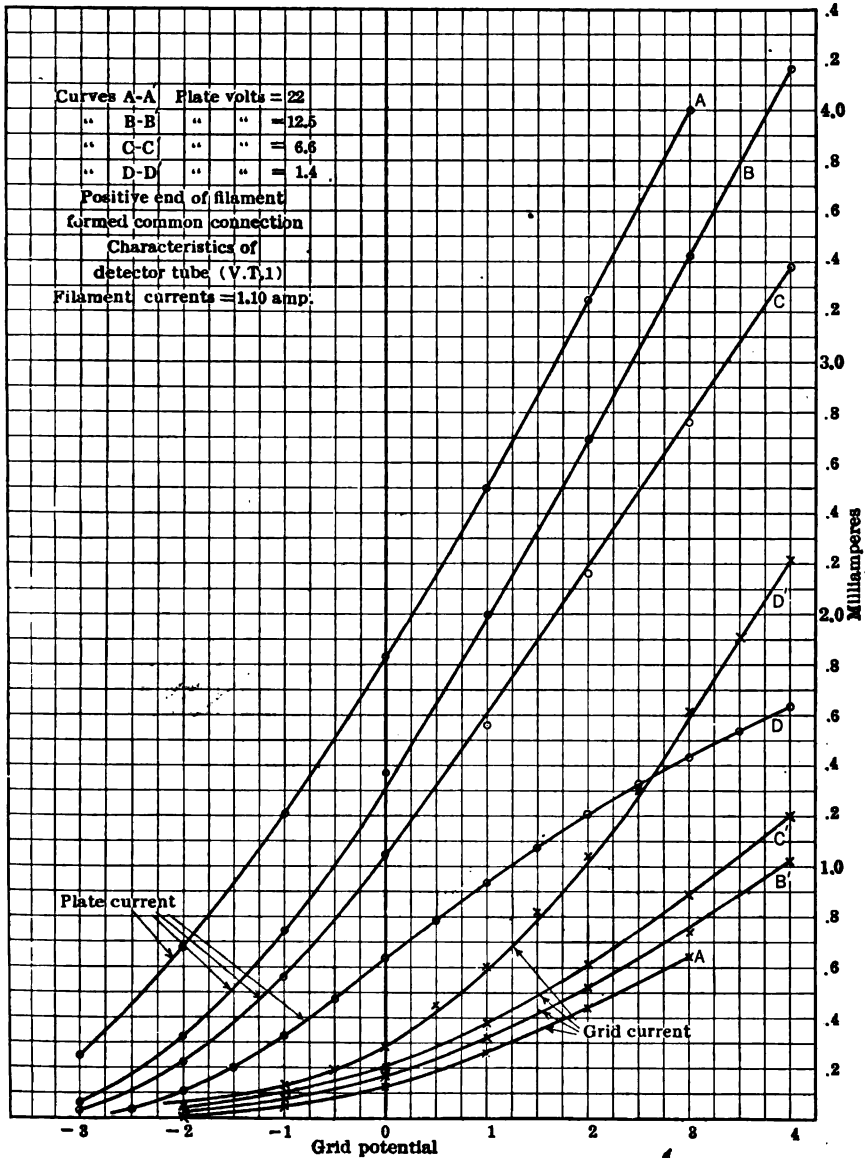

FIG. 29.—Characteristic curves for an ordinary detector tube, for a wide range of plate voltages. For the lowest plate voltage the grid current and plate current are about equal.

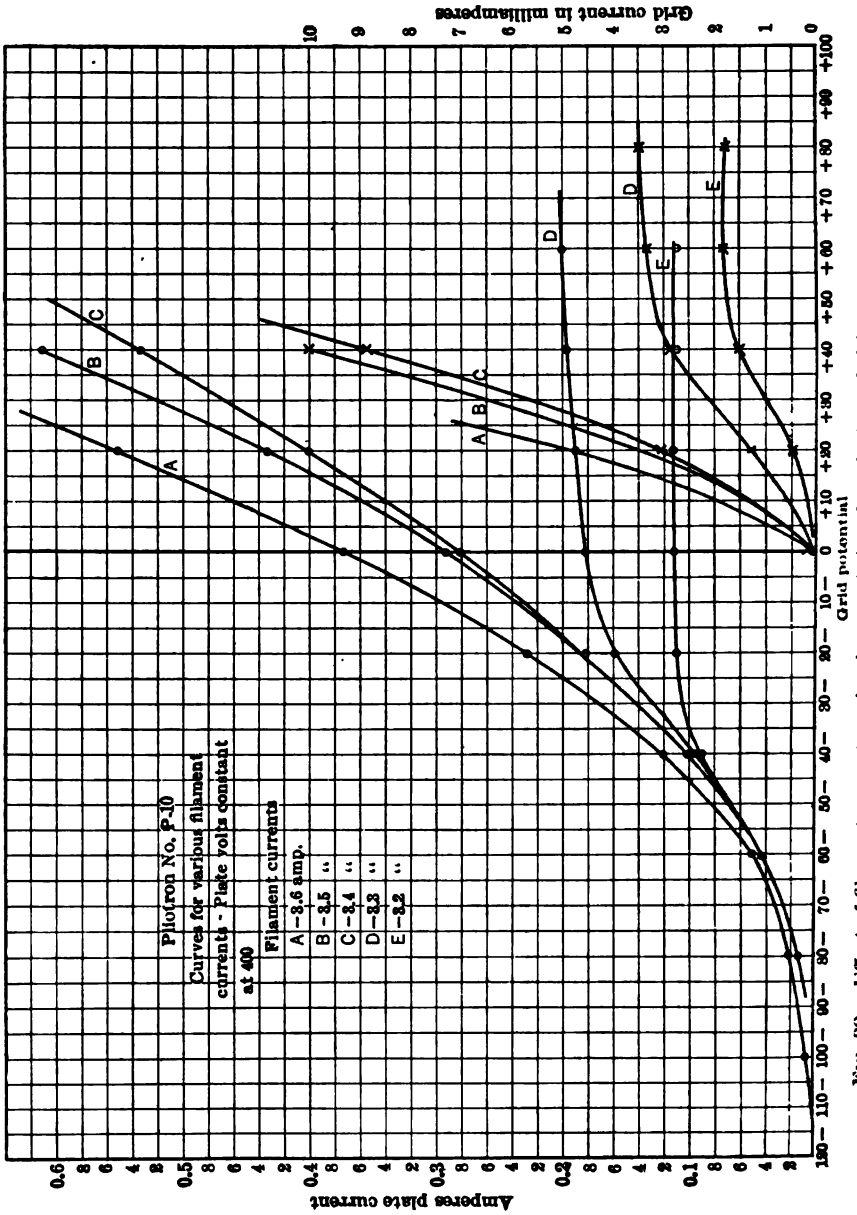

Fig. 30.- Effect of filament current on the characteristics of a tube intended for a power generator.

the plate current and battery heating current combine to give a current greater than normal battery current.

In Fig. 32 are shown curves for the same tube as used for Fig. 30; the filament current (larger value) was held at 3.60 amperes and various

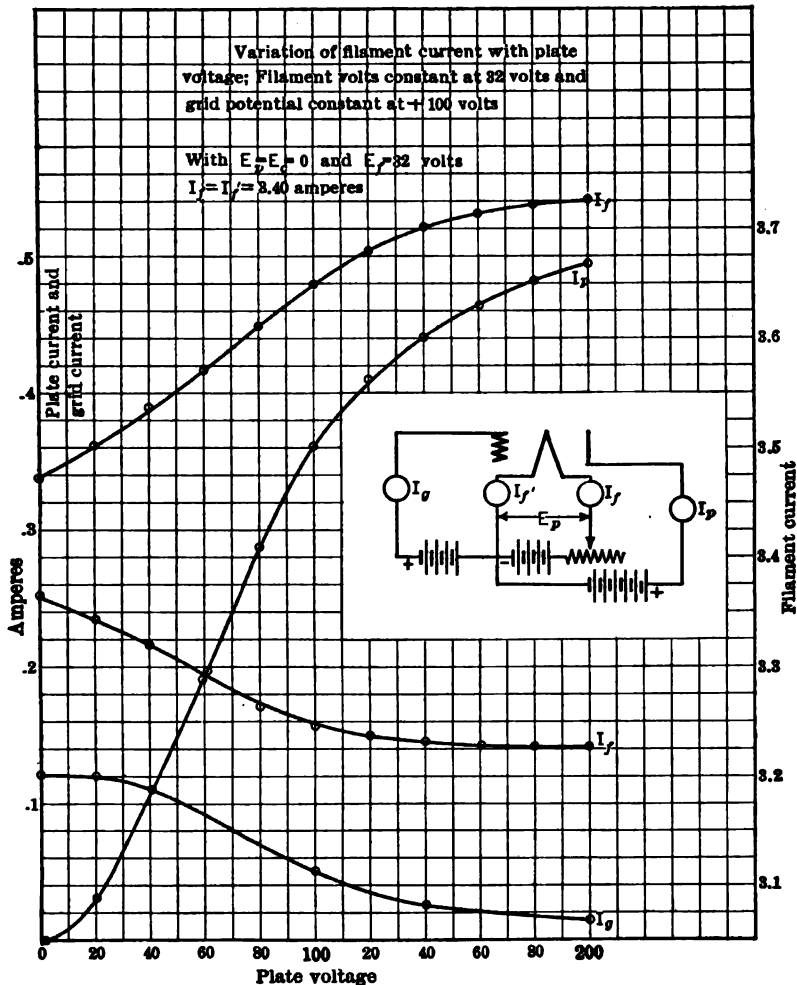

FIG. 31.—Showing the effect of the plate voltage upon the filament current of a power tube, the voltage impressed on the filament being constant. The change in grid current produced by increasing plate potential is also shown.

voltages were impressed on the plate. With low plate voltage it is seen that when the grid becomes positive the plate current undergoes a rapid decrease. This combination of high positive grid voltage and low plate voltage occurs when the tube is used for generating power and results

in peculiar-shaped plate current instead of a sinusoidal variation as is generally assumed.

In Fig. 33 are shown the characteristic curves for a G. E. P-20 (20 grid wires per inch) plotron obtained by holding the grid potential constant

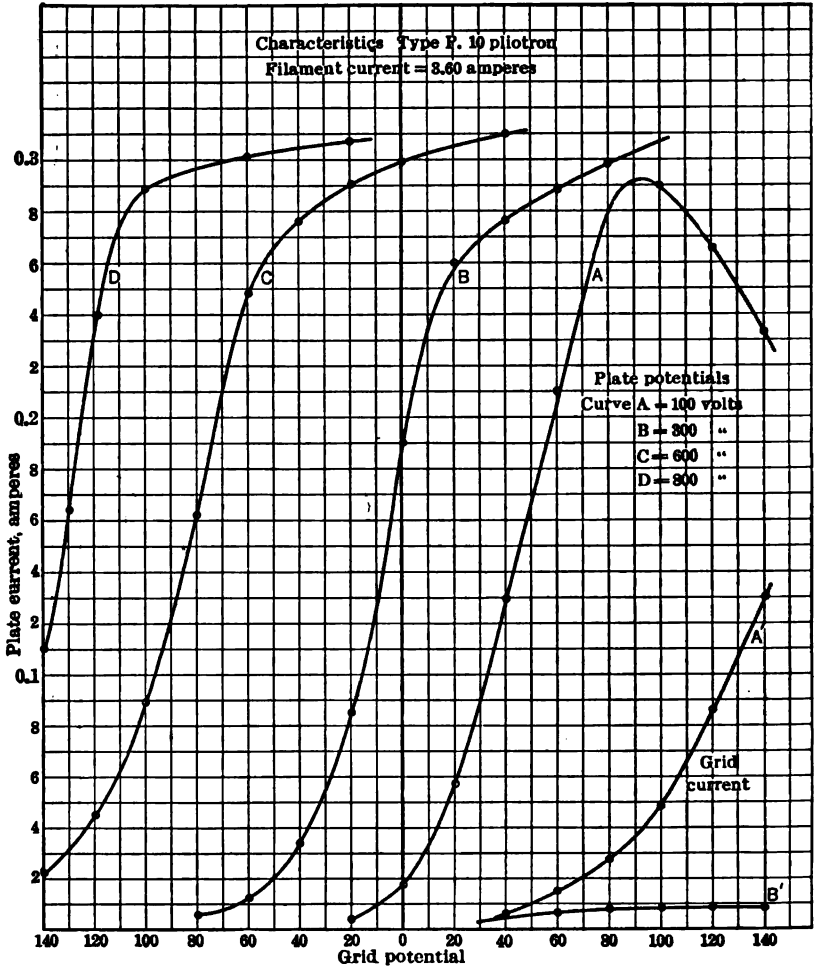

FIG. 32.—Static characteristics of a Type P plotron for various plate voltages, filament current being constant.

while varying the plate voltage. For all these curves the grid currents were only a few microamperes. In this tube it is evident that 1 volt on the grid has the same effect on plate current as 11 volts on the plate.

In Fig. 34 are shown similar curves for a P-10 plotron, values having been obtained for low plate voltage and high positive grid voltages and in

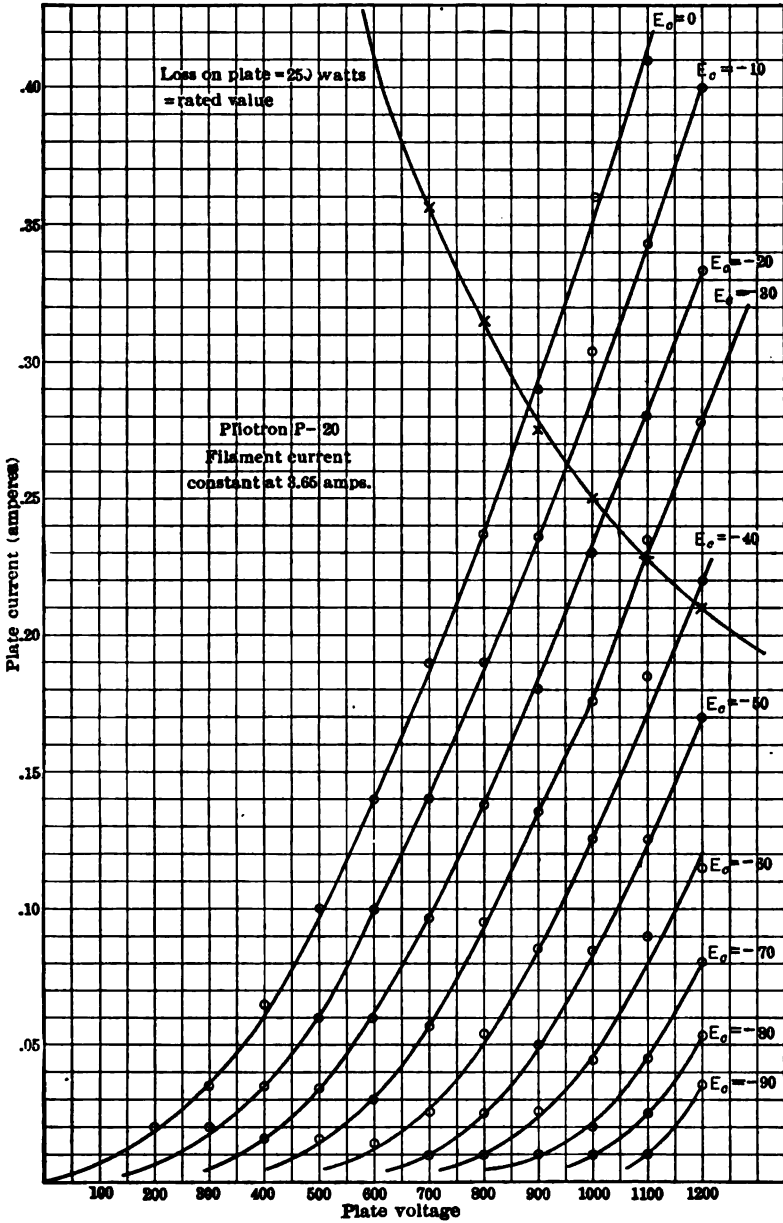

FIG. 33.—Static characteristics of a Type P tube for various fixed grid potentials and variable plate voltage. The curve in the upper part of the diagram shows the limit of operation of the tube.

Fig. 35 are shown some typical curves for a finer-mesh grid (P-30). In this tube the grid voltage is twenty-two times as effective as the plate voltage in determining plate current. It will be noticed how quickly the grid current rises as the plate potential decreases beyond a certain limit.

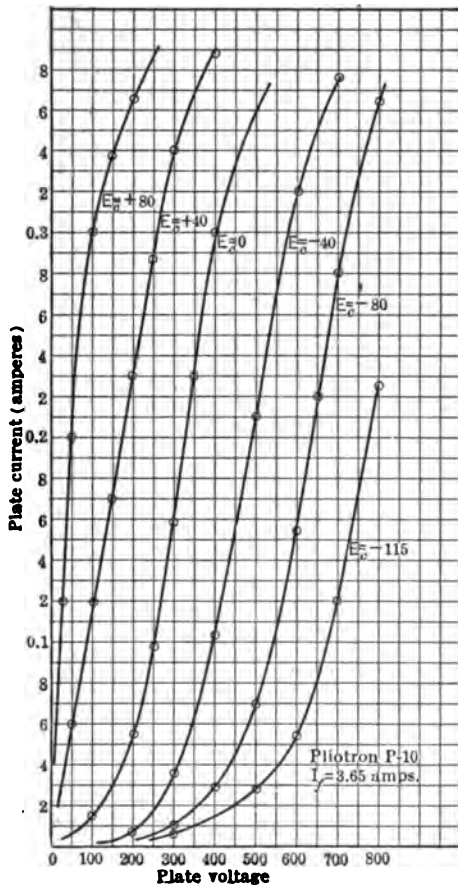

FIG. 34.—Similar to the curves of Fig. 33, this tube having a grid with coarser mesh.

exceeds one megohm in ordinary detecting or amplifying sets.

In Fig. 36 is shown a connection in which a free grid is used; tube 1 is repeating into tube 2, the fluctuations of plate voltage of 1 being impressed on the grid of 2. The grid of 2 cannot be connected directly to the plate of 1 because this plate is at comparatively high positive potential, due to its *B* battery. By putting an insulating condenser *C* between the plate of 1 and grid of 2 the fluctuations of plate voltage repeat through the condenser into the grid, but the grid is insulated from the high positive continuous e.m.f. of the plate of 1.

Potential of the Free Grid of a Three-electrode Tube.—

When the grid of a vacuum tube is entirely disconnected from other circuits it is said to be "free," meaning that it is free to assume any potential circumstances may demand. Actually a grid is never really free, because there is always some leakage from the grid to the plate and filament even in tubes with extremely high vacuum. If the value of this leak resistance is perhaps 50 megohms the grid may be reckoned as free, although in many tubes a much greater resistance exists and the grids are correspondingly more "free."

It is almost an axiom in vacuum-tube operation that a grid should never be left free. Consistent operation of the tube is almost impossible unless the resistance between the grid and filament is of definite value, and sufficiently low; it seldom

Now such a grid is free; the insulation of condenser *C* will be hundreds of megohms, so that the grid is free to assume any potential whatever. Because of the irregular action of a tube so connected a high resist-

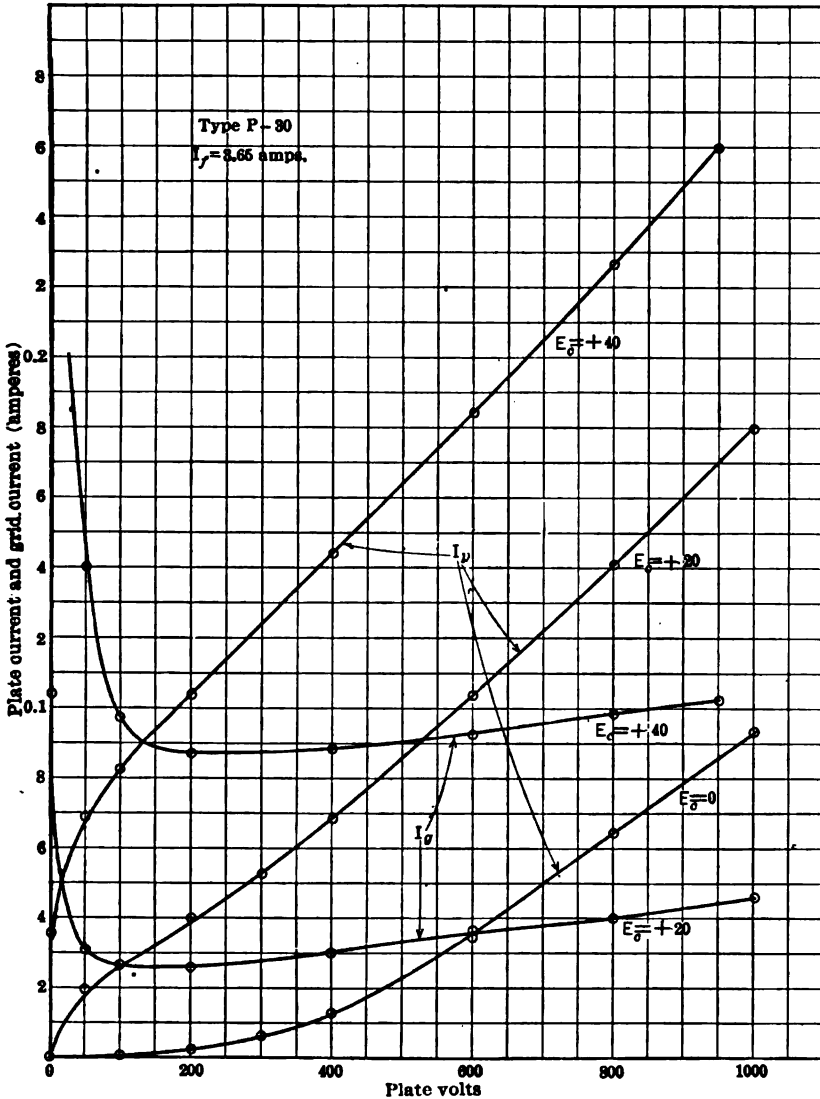

FIG. 35.—Similar to the curves of Fig. 33, this tube having a grid with finer mesh.

ance leak of one megohm or less (as indicated by the dotted line connection) is always used, to keep the grid, normally, at a suitable potential.

Some of the effects produced by a free grid will be indicated by the

accompanying curves. In Fig. 37 is shown how the potential of a free grid may be expected to change as the plate voltage is increased from

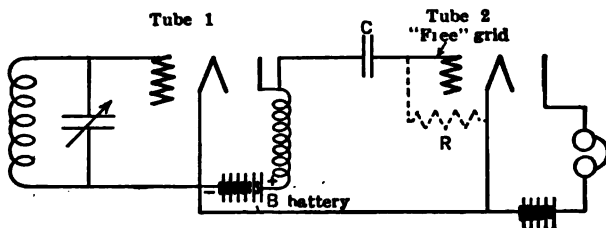

FIG. 36.—A circuit illustrating the meaning of the term "free grid," the grid of the second tube is electrically free to assume any potential that circumstances may demand.

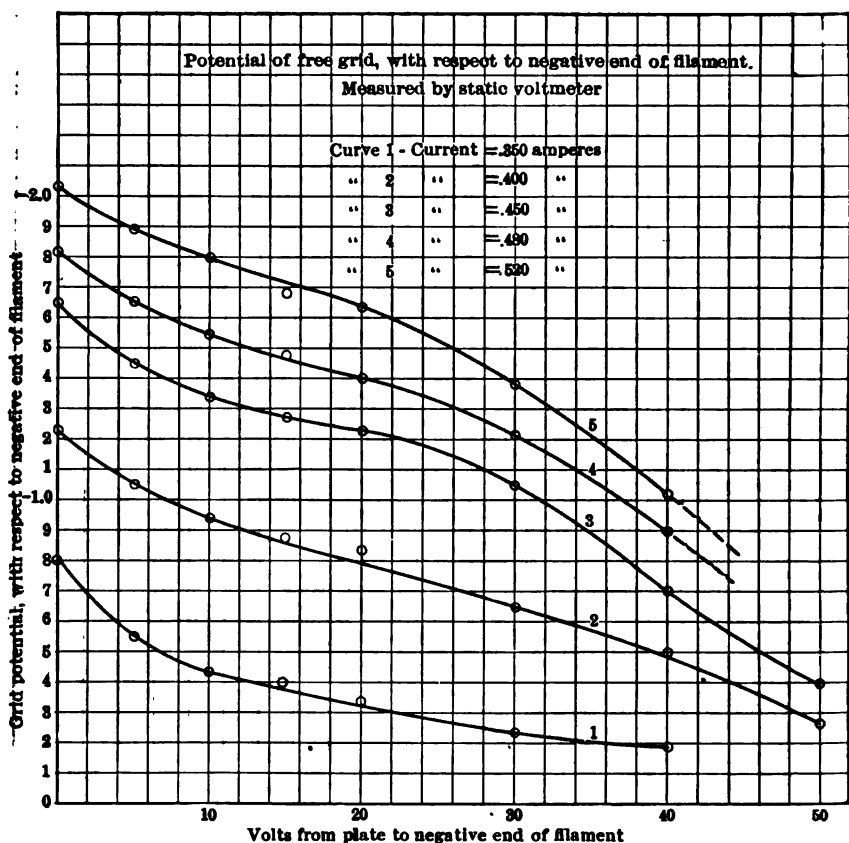

FIG. 37.—Variations in free grid potential for various plate voltages and filament currents; measurements by a highly insulated sensitive static voltmeter.

zero, for various filament temperatures. The higher the plate voltage the closer the grid potential approaches zero potential, i.e., that of the

negative end of the filament. With zero plate voltage the grid goes negative as much as 2 volts, due undoubtedly to the accumulation of electrons which have left the filament with enough initial velocity to carry them as far as the grid.

In Fig. 38 are shown the free grid potentials of ten different tubes all of them having some gas (although not enough to produce visible ionization with the plate potentials used). In getting these curves the filament current was brought to its normal value with plate at the desired voltage, the grid being connected to the negative end of the filament. The grid was then disconnected from everything and the plate current noted; by then connecting the grid to a suitable potentiometer and varying its potential the same value of plate current was obtained. A voltmeter connected across the potentiometer served to show this grid potential which, as it gave the same plate current, must be that of the free grid.

The potential of the free grid depends entirely on the order in which the successive adjustments are carried out, thus if the grid is left free, filament current brought to normal and then plate potential brought to normal an entirely different value for free grid potential may be obtained than would be if the plate were first put at its proper potential and then the filament current brought to normal.

In Fig. 39 is shown the curve obtained (with free grid) by holding the plate at 150 volts, increasing the filament current from a low value to a high value and then decreasing the filament current through the same range. A peculiar loop is obtained explained by the fact that as the plate potential was applied before there was a liberal supply of electrons in the vicinity of the grid the grid went positive. This positive grid gave comparatively large values of plate current from *A* up to the point *B* on the curve sheet; here the grid suddenly lost most of its positive charge due to bombardment by many electrons, and became nearly zero in potential with a consequent decrease in the plate current. From *C* to *D* and back to *C* the grid had nearly the same potential for increasing as for decreasing filament current, but from *C* to *E* the grid potential was much lower than it was for the corresponding values of filament current, when increasing values were being taken. At *E* the grid suddenly increases its potential a small amount and for the remainder of the cycle it has about the same potential as it had for increasing filament current; other tubes showed exactly the same effect.

In Fig. 40 are shown the potentials of the free grid of a telephone amplifying tube. For low values of filament current the free grid assumes a potential about half that of the plate, then as the filament current is increased the grid potential decreases gradually until a critical value of filament current is reached. At this critical filament current (i.e., critical supply of electrons) the grid potential suddenly falls to a comparatively

POTENTIAL OF FREE GRID WITH RESPECT
TO NEGATIVE END OF FILAMENT

Measured by potential applied to grid to produce
no change in plate current

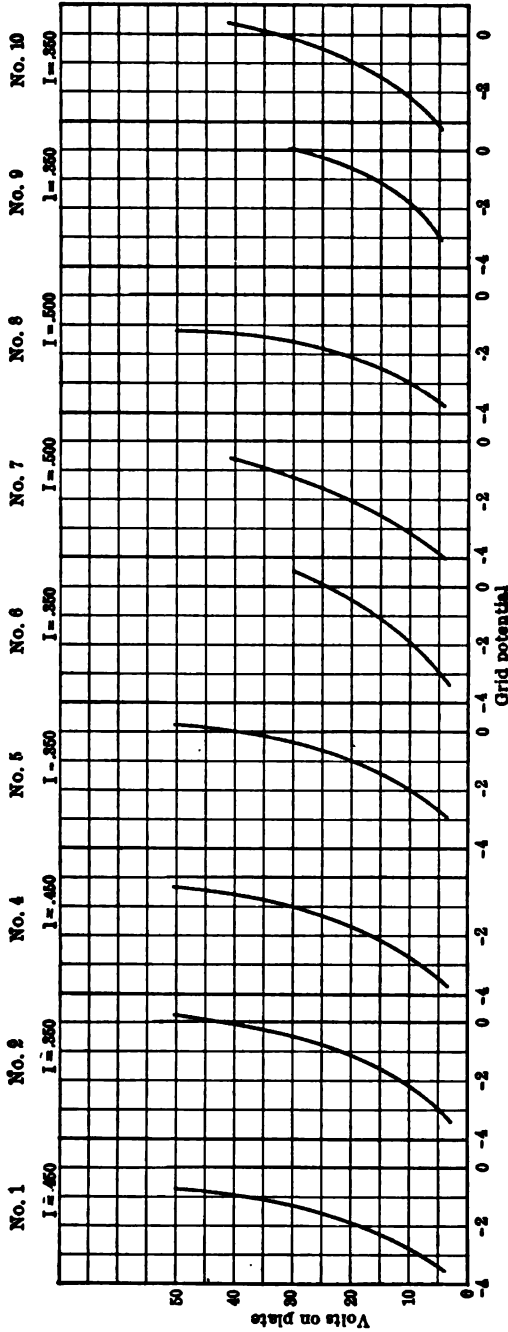

Fig. 38.—For the several tubes tested, the free grid potential increased always with increasing plate potential; for a few tubes the free grid potential goes positive in the operating range of plate voltage.

low value, which value decreases somewhat as the filament current is still further increased. It will be noticed that for this tube the free grid is always positive, whereas for the ten tubes tested for Fig. 38 most of the grid potentials were negative.

Relations between Currents and Potentials in a Three-electrode Tube.—From experimental results already presented it is evident that the grid current and plate current of a three-electrode tube vary with either filament current, plate voltage, or grid voltage. It is also evident that the grid current is negligibly small compared to the plate current, and that the plate current is not affected directly by the grid current

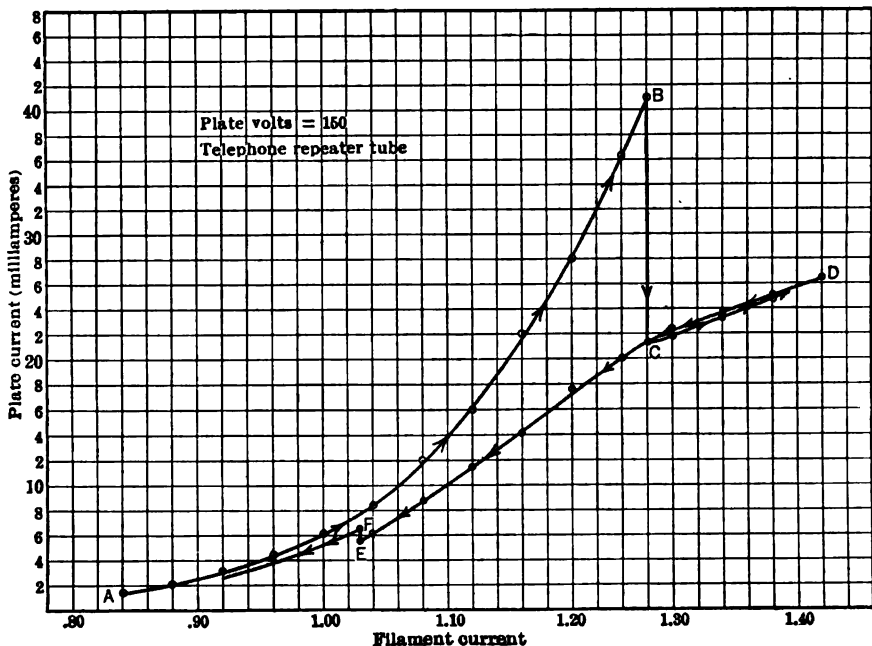

FIG. 39.—A peculiar cycle obtainable from a tube having a free grid; as the filament current was increased and then decreased the plate current went around the loop as indicated by the arrow heads; plate potential was kept constant.

except under unusual conditions, as, e.g., curve A of Fig. 32. Unless we are specifically interested in the losses in the grid circuit the grid current may be neglected. Furthermore, unless the conditions are such that saturation current is reached (plate current using all the electrons emitted from the filament) the filament current does not affect the plate current to a great extent. We shall therefore examine in this section, the relations between plate current and grid and plate potentials, neglecting grid currents and the effect of too small a filament current.

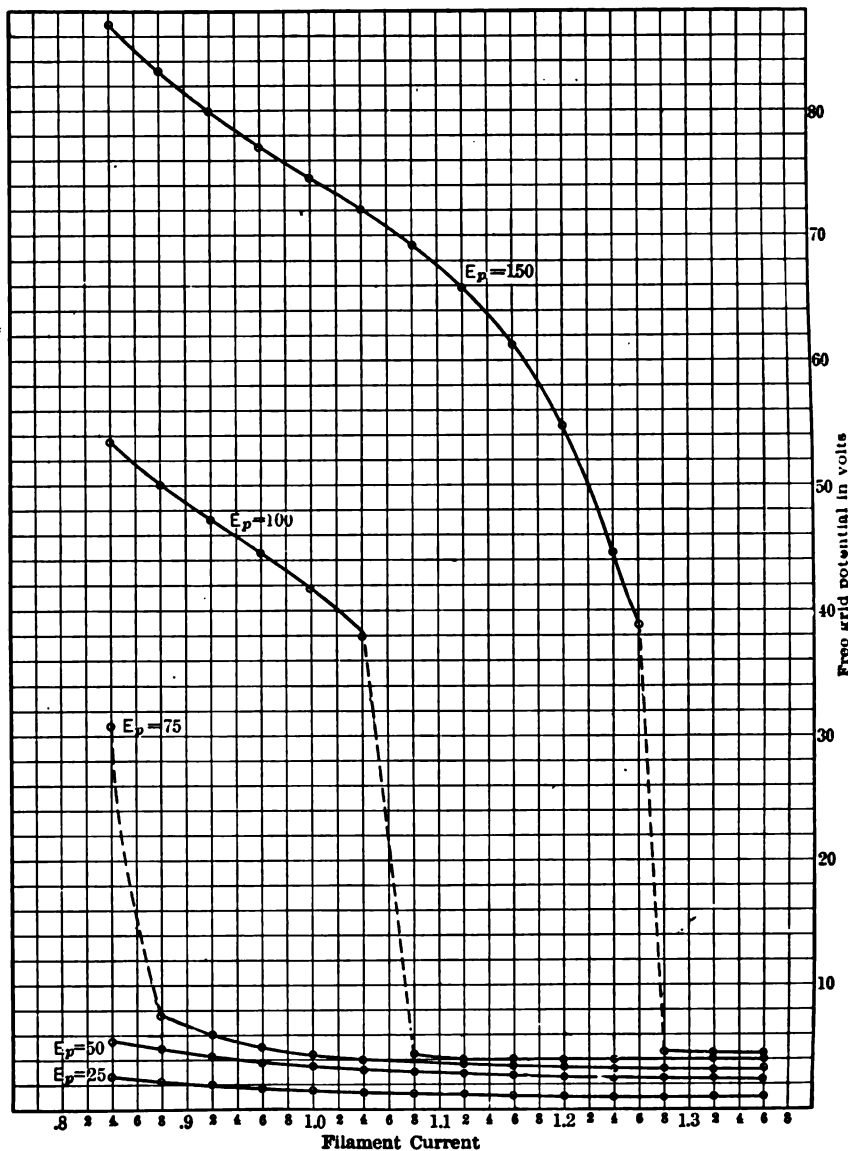

FIG. 40.—Showing the peculiar variations in free grid potential as filament current was increased; for this special tube the free grid assumed positive potential under all conditions.

scales, so that for various types of tubes to be tested the plate current will give indications well up on the scale. The filament battery should be perhaps 6 volts and E_b and E_c should have voltages suitable for the tubes to be tested.

With S open E_b , E_c , and I_f are put at their proper values and the reading of A_2 is noted. Then S is closed, permitting current I to flow around the circuit E , R_1 , R_2 , E , the reading of A_2 will in general change; by properly adjusting R_1 , however, it will be found that the reading of A_2 (which is the plate current) does not change when switch S is closed. The ratio of R_1 to R_2 for this adjustment gives μ_0 .

By examination of Fig. 41 it will be seen that depressing key S raises the voltage impressed on the plate by an amount IR_1 , and depresses the voltage of the grid by an amount IR_2 . From inspection of Eq. (5) it is evident that if I_p does not change when S is closed,

$$(\Delta E_p + \mu_0 \Delta E_g) = 0,$$

where ΔE_p and ΔE_g are the changes in E_p and E_g due to closing switch S . We therefore have the relation

$$IR_1 + \mu_0 IR_2 = 0,$$

or

$$\mu_0 = \frac{R_1}{R_2} \dots \dots \dots (6)$$

With this scheme it is possible to investigate the dependence of μ_0 on E_p , E_g , and I_f very quickly.

The value of R_1 should not be so high that the drop through it, due to the plate current, is an appreciable fraction of E_b , otherwise the plate potential will not be E_b , but something less, and must be calculated.

The value of the exponent x should theoretically be a constant, but in the actual tube it is constant only for a limited range of voltages. The voltage between the plate and filament is different for the different parts of the filament, and the velocity of emission of the electrons may not be negligible when the plate and grid voltages are low.

If the grid is held at zero voltage the relation between I_p and E_p is $I_p = AE_p^x$. The determination of the exponent x is most easily carried out by plotting the various values of I_p and E_p on logarithmic cross-section paper; if x is a constant the graph is a straight line with slope equal to x . If the graph is not a straight line the value of x varies, but it may be determined for any value of E_p by measuring the slope of the graph.

Figs. 42 and 43 give the variations between plate current and plate voltage for two amplifying and detecting bulbs designed for 40 volts on the plate and an IR drop in the filament of about 3.5 volts. The two

curves were transposed to logarithmic paper, giving the graphs shown in Fig. 44, the straight dotted line shows the slope the two curves would have if the plate current varied with the square of the plate voltage. From the logarithmic graphs the values of x were measured and transferred to Figs. 42 and 43 to give the curves of x there shown.

In Fig. 45 is shown the logarithmic graph for a high power plotron, the rated plate voltage being 1000-2000 volts; it is seen that for high plate voltages the plate current varies as the square of the plate voltage. For the lower plate voltages the IR drop in the filament (about 20 volts) and the velocity of emission of the electrons tend to give an exponent other than 2; however, if the grid is held

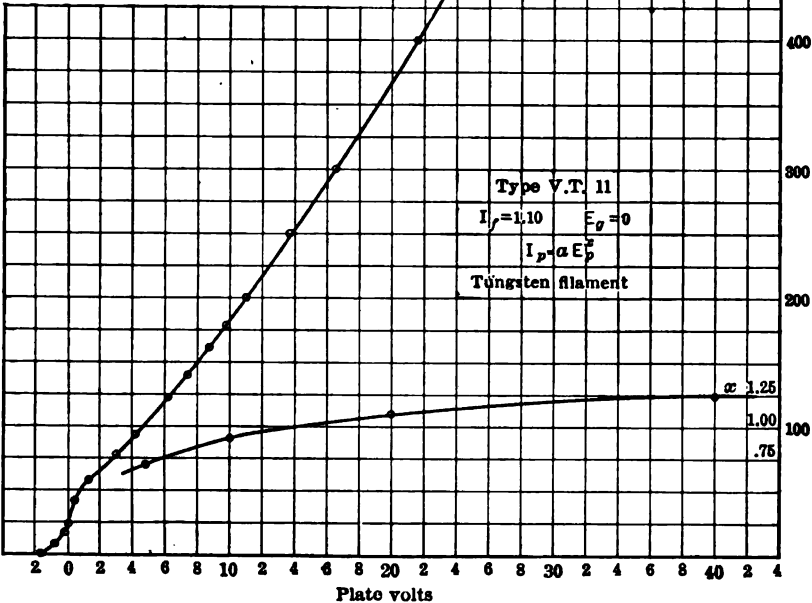
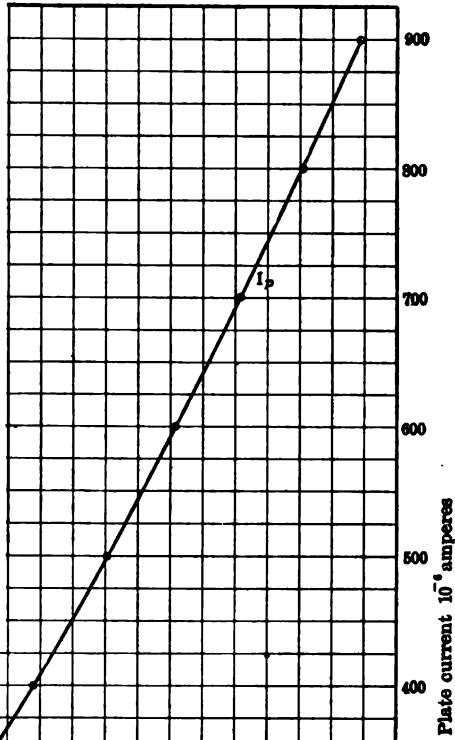

FIG. 42.—Variation of plate current in a tungsten filament tube as E_p is varied and grid potential held constant; values of the exponent of Eq. (5), p. 417.

at -10 volts, the plate current follows the square law very closely throughout the range of the graph. A greater negative potential makes

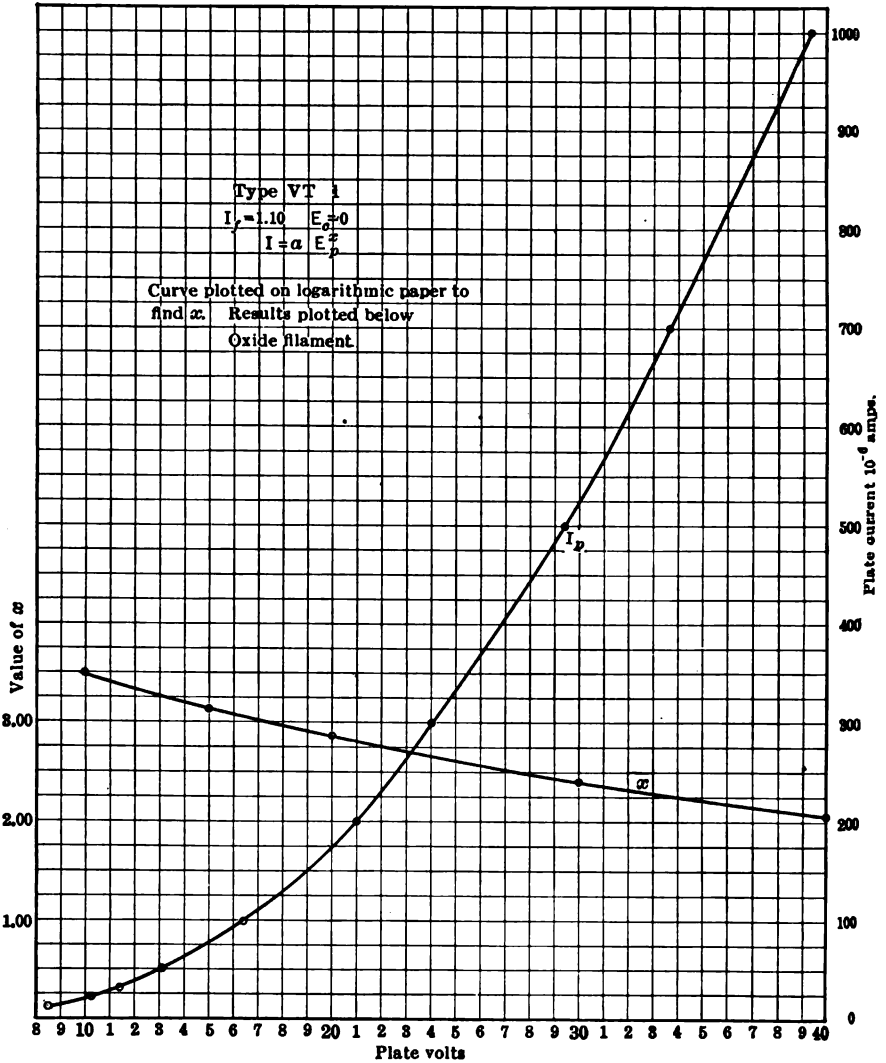

FIG. 43.—Curves similar to those of Fig. 42, the tube used having an oxide-coated filament.

the plate current vary with higher power of plate voltage for the lower values of plate potential; this is to be expected from inspection of Eq. (5).

Different tubes of the same type will not follow exactly the same law of plate current variation, due probably to small differences in the struc-

ture. In Fig. 46 are shown the results of tests on twenty-four tubes all having the same rating; twelve had oxide coated filaments with a filament IR drop of 2.6 volts and the other twelve had tungsten filaments with an IR drop of 3.6 volts. The curves for the individual tubes ran in general, parallel to the boundaries of the cross-sectioned areas, as indicated on this curve sheet

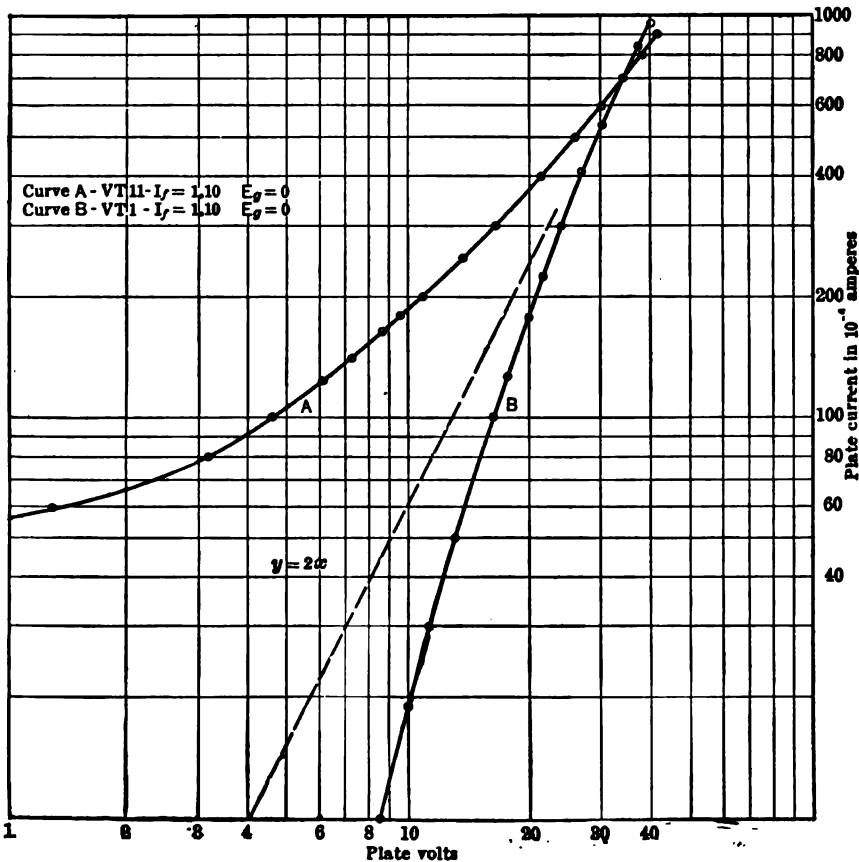

Fig. 44.—The curves of Figs. 42 and 43 transposed to logarithmic coordinates; this graph shows that the exponent for Eq. (5) is neither 1.5 nor 2, but is a variable for both tubes.

Resistance of the Circuits of a Three-electrode Tube and its Variations.—There are three circuits to be considered in getting the characteristics of three-electrode tubes, the filament, the grid to filament circuit, and the plate to filament circuit. The grid to filament is called the *input circuit* of the tube, and the plate to filament is called the *output circuit* of the tube.

In the ordinary small detecting and amplifying tube the filament current is practically independent of any changes in the grid and plate circuits. In large power tubes, however, this is not so, the resistance of the filament varying a good deal as either the grid or plate potential is varied, this variation being shown by impressing constant voltage on the filament and then impressing various potentials on the grid and plate.

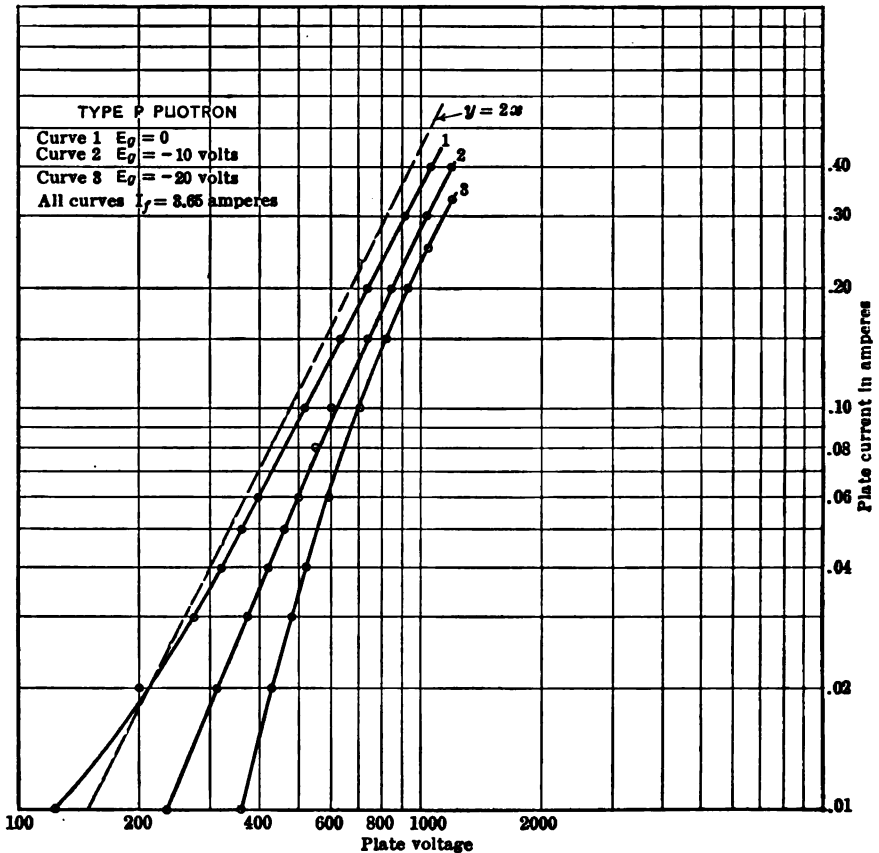

FIG. 45.—Logarithmic plot of the plate current curve for a high-voltage power tube; with a certain constant negative grid potential the plate current of this tube varies with the square of the plate voltage.

The accompanying changes in grid and plate current cause a non-uniform current to flow through the conductor, under which condition the filament has a different resistance than it has when the current is the same everywhere through its length.

The resistances of the input and output circuits vary throughout extreme ranges, and they are different for alternating current than for

continuous current; we shall first consider the output circuit. The ratio of plate voltage to plate current is generally called the *output impedance*. As there can be no appreciable lag in the motion of the electrons behind the impressed electric field, it might seem more appropriate to speak of output resistance instead of output impedance. But it is to be remembered that the plate current is influenced by the grid as well as by the plate,

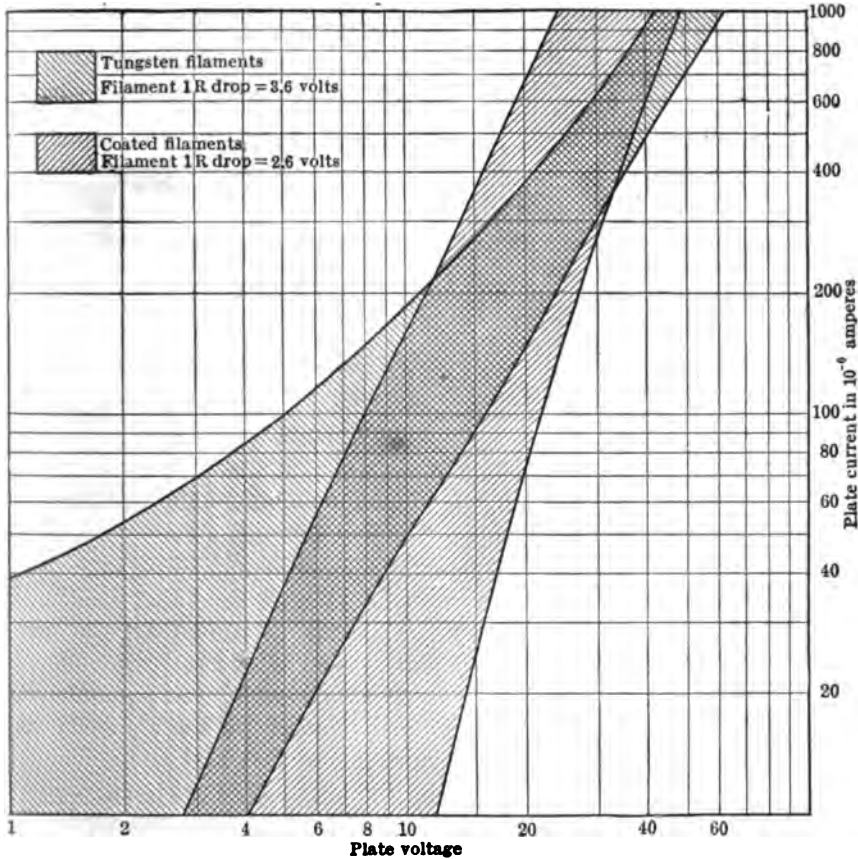

Fig. 46.—Logarithmic plots of 24 typical detector tubes, 12 with tungsten filaments and 12 with oxide-coated filaments. The curves for the individual tubes lay inside the areas as noted.

and it may well be that variation of plate current is not in phase with the variation of plate potential. From this viewpoint the plate filament circuit has impedance, not merely resistance.

If, however, we maintain the grid at zero potential (or any other fixed potential) the plate current will vary with plate voltage only and we may speak of plate circuit resistance. With constant grid potential and vary-

ing plate potential the values of plate current determine this resistance of the plate circuit, R_{op} , for continuous currents. Such a curve for a tungsten filament detecting tube is shown in Fig. 47; on the same curve sheet is shown a curve of μ_0 for this tube, from which it may be seen that the value of μ_0 is practically constant, except for very low plate voltages.

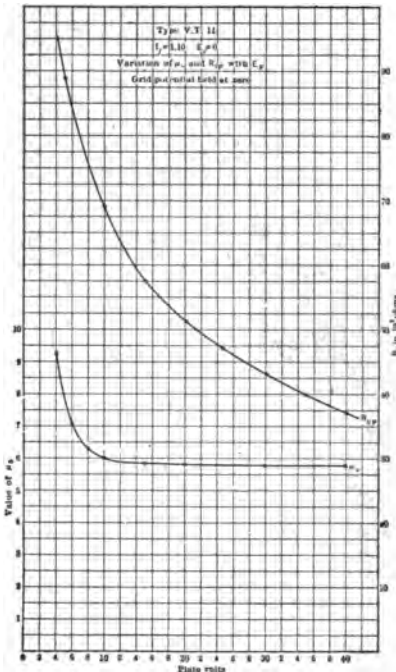

FIG. 47.—Curves of μ_0 and R_{op} of a small tungsten filament tube; the value of R_{op} is obtained by finding the quotient of E_p by I_p in a continuous-current test.

The value of μ_0 is practically constant, except for very low plate voltages. The value of R_{op} continually increases as E_p is diminished.

The value of the alternating current resistance, R_p , is determined by the ratio of $\frac{dE_p}{dI_p}$, the grid voltage being maintained at zero; we may write

$$I_p = aE_p^x$$

or
$$\frac{dE_p}{dI_p} = \frac{1}{axE_p^{x-1}} = R_p$$

But the continuous current resistance is

$$R_{op} = \frac{E_p}{I_p} = \frac{1}{aE_p^{x-1}}$$

From these we get the relation,

$$R_p = \frac{R_{op}}{x} \dots \dots (7)$$

In Fig. 48 are shown the curves of R_p and R_{op} for an oxide-filament amplifying tube; the points indicated by circles on the R_p curve were

obtained by the alternating current measurement and those indicated by crosses were obtained by dividing the points on the R_{op} curve by the proper value of x . On the same curve sheet is shown the value of μ_0 for this tube; it is nearly constant in the working range of the tube (E_p between 20 and 40 volts) and falls off with the lower plate voltages, whereas the curve of Fig. 47 showed an increasing μ_0 with lower plate voltages.

The value of R_p is found experimentally by the scheme outlined in Fig. 49, originated by J. M. Miller; the same arrangement serves to measure μ_0 by alternating-current test providing the phone resistance is negligible compared to the tube resistance. Fig. 50 shows a curve of μ_0 obtained by the method; it shows μ_0 to be independent of filament

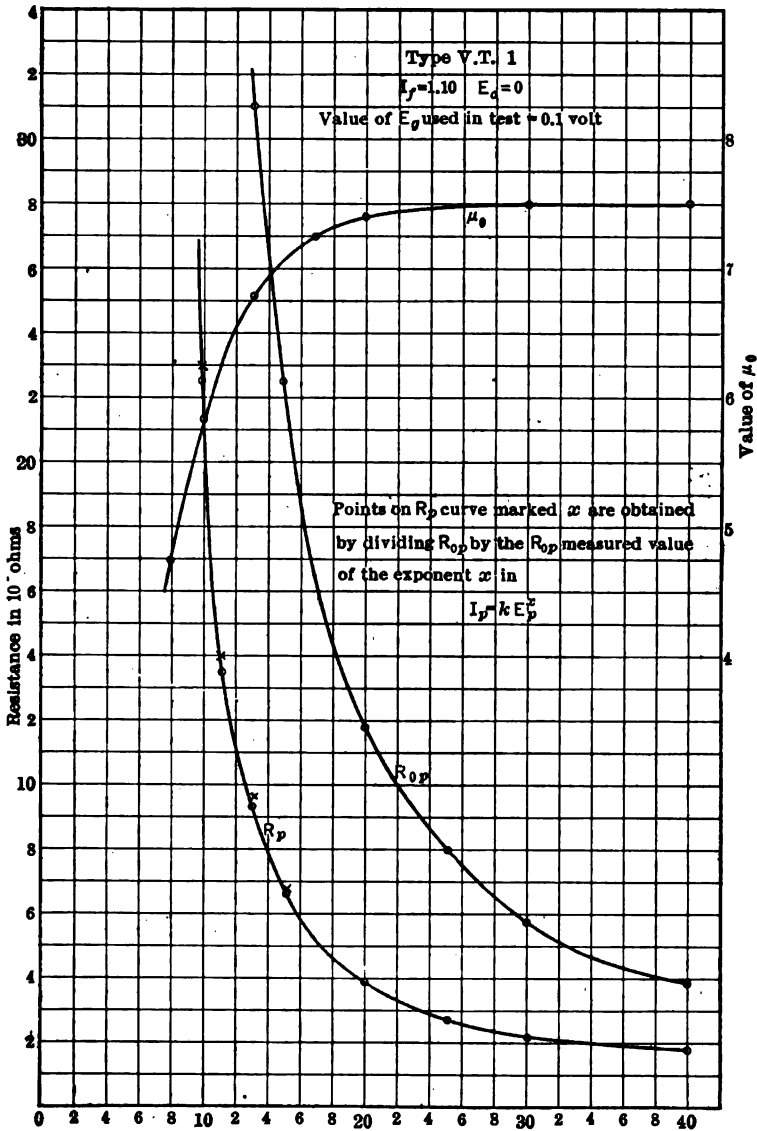

FIG. 48.—Curves of μ_0 , R_p , and R_{op} , of an oxide-coated detector tube; the curve of R_p can be obtained by dividing values of R_{op} by the corresponding value of x of Eq. (5). Such values are indicated on curve of R_p by x .

current. With S_2 open and S_1 closed the ratio of r_1 to r_2 is varied until no signal is heard in the telephone and we then have

$$\mu_0 = \frac{r_2}{r_1} \dots \dots \dots (8)$$

In measuring R_p , r_1 and r_2 are fixed at some convenient value (say equal to each other), and with S_2 closed R is varied until no signal is heard in the phone when S_1 is closed. With this adjustment we have

$$R_p = R \left(\frac{r_1}{r_2} \mu_0 - 1 \right) \dots \dots \dots (9)$$

Flowing through the potentiometer there is a current i , which gives

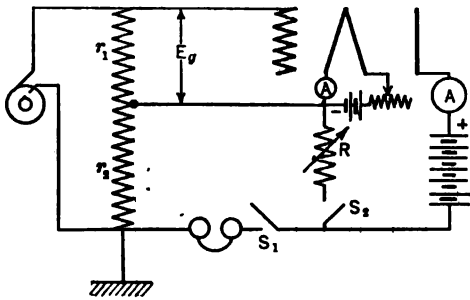

FIG. 49.—An arrangement of apparatus for conveniently measuring the μ_0 of a tube as well as the alternating current resistance of the output circuit.

a drop between grid and filament $= Ir_1 = E_g$. If the alternating voltage E_g is impressed on the grid of a vacuum tube it will produce an alternating current in the plate circuit, I_p . Of course the actual plate-circuit current is not alternating, it is pulsating; this pulsating current may be resolved into a steady current I_{op} and an alternating current I_p . The current I_{op} is produced by the steady values

of E_g and E_p , and the alternating current I_p is caused by the variations in E_g .

The magnitude of this current I_p can be calculated by remembering that a voltage E_g in the grid circuit is equivalent to a voltage $\mu_0 E_g$ in the plate circuit. This voltage, $\mu_0 E_g$, will cause an alternating current to flow in the plate circuit which is equal to $\frac{\mu_0 E_g}{R_p + R}$. This current flowing through the resistance R must give a drop equal to $\frac{\mu_0 E_g R}{R_p + R}$ and if there is no signal heard in closing S_1 this drop must equal that across r_2 which is equal to $E_g \frac{r_2}{r_1}$ when a balance is obtained. We therefore have,

$$E_g \frac{r_2}{r_1} = \mu_0 E_g \frac{R}{R_p + R}$$

Solving this equation for R_p we get the relation given in Eq. (9) above.

In case the resistance R does not permit a balance to be obtained, it being too small, the ratio of $\frac{r_2}{r_1}$ can be suitably altered.

The relation between I_p and E_g is not a linear one and it is therefore evident that R_p must vary throughout the cycle of change in E_g . The value of R_p is therefore represented correctly only by a constant (the

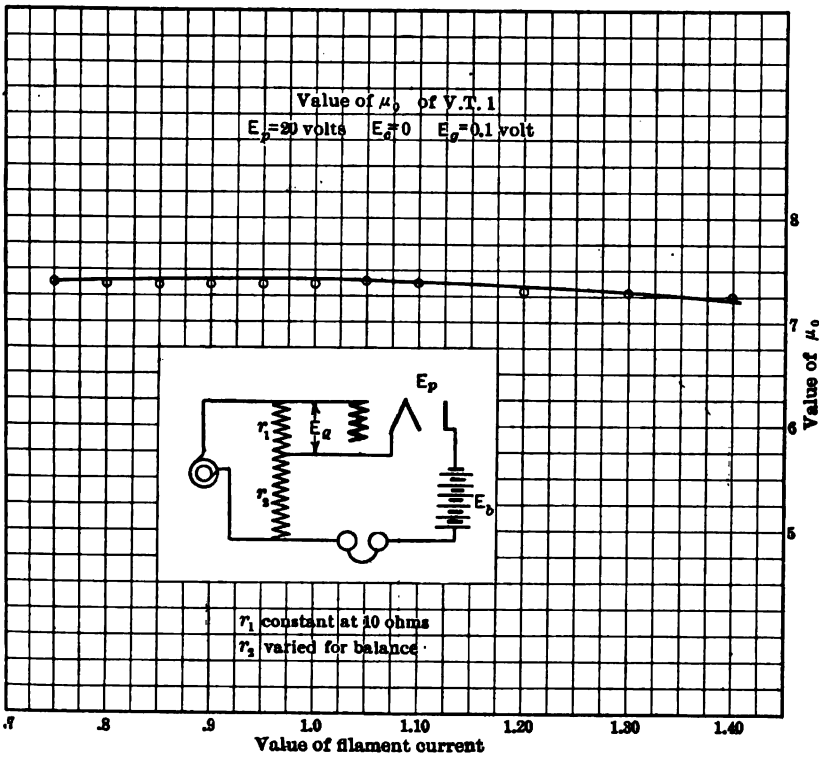

Fig. 50.—Value of μ_0 of a small amplifying tube, obtained by the scheme outlined in Fig. 49; this shows μ_0 to be nearly independent of the filament current.

value of which we call R_p) and a series of harmonic terms; these harmonic terms become more pronounced as E_g is varied through wider ranges.

In the measurement of R_p by the method outlined above it will be found that complete silence cannot be obtained at the balance point; the note heard in the telephone is complex and only the fundamental note can be balanced. A balance will generally be most easily obtained if comparatively low values of E_g are used, say not more than 0.1 volt; moreover it will be found that the value obtained for R_p varies with E_g , becoming greater for high values, as explained on p. 499.

The resistance of the input circuit (grid-filament) for continuous current is practically infinite for all values of negative voltage; the current taken by the grid of the average tube when the grid is at lower potential than any part of the filament is of the order of one microampere or less. With a positive grid the current to the grid varies approximately as the square of the grid potential. When the grid and plate are at the same positive potential, the two currents are of the same order of magnitude (see Figs. 35, 32, and 29), so that the grid-filament resistance R_g ,

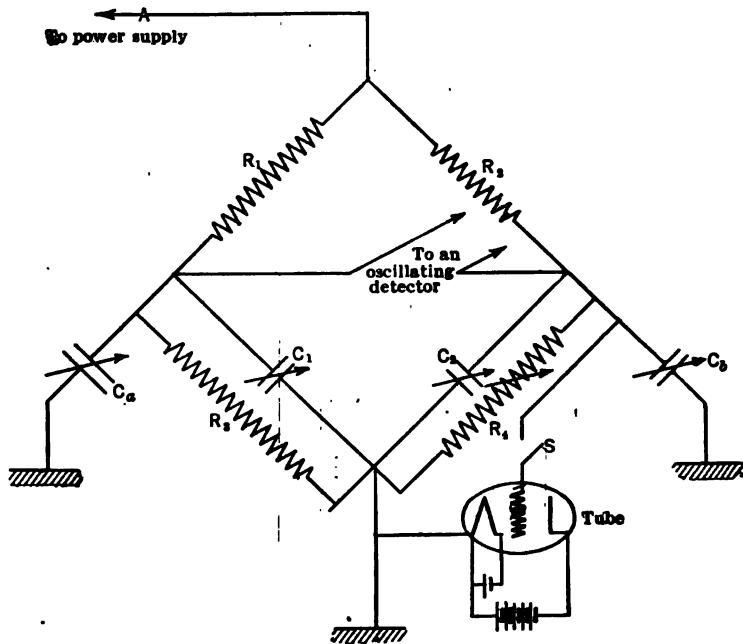

FIG. 51.—A suitable bridge arrangement for making high-frequency measurements with the two lower arms open the condensers C_a and C_b serve to balance out spurious capacities in arms R_1 and R_2 .

is about the same as the plate-filament resistance R_p . It goes through the same kind of changes with respect to filament current, grid voltage, etc., as does R_p . It is to be noted from the curve sheets, however, that whereas an increase of E_g decreases R_g and increase in E_p causes an increase in R_g .

To measure the alternating current input resistance, a scheme such as that illustrated in Fig. 49 is not directly applicable; for any ordinary scheme of measurement a transformer will be required to decrease the grid circuit resistance to a value readily measured.

The author has used a bridge for measuring the characteristics of the input circuit of various tubes, the measurement being made at 50,000

cycles. The scheme used is illustrated in Fig. 51; the same setting of the bridge permitted the measurement of both capacity and resistance of the tube input circuit. The 50,000-cycle power was supplied to the bridge by wire *A*, the other side being grounded. The condensers C_1 and C_2 are adjusted to balance the bridge when the (3) and (4) arms are open, to neutralize any spurious capacity in the bridge ratio arms and are left set after once being balanced (unless ratio is changed). Suitable high-resistance leaks are shunted across C_1 and C_2 , these resistances being free from appreciable distributed capacity. Certain precautions have to be observed in using such a bridge as noted in an article by the author in the Proc. I.R.E.¹

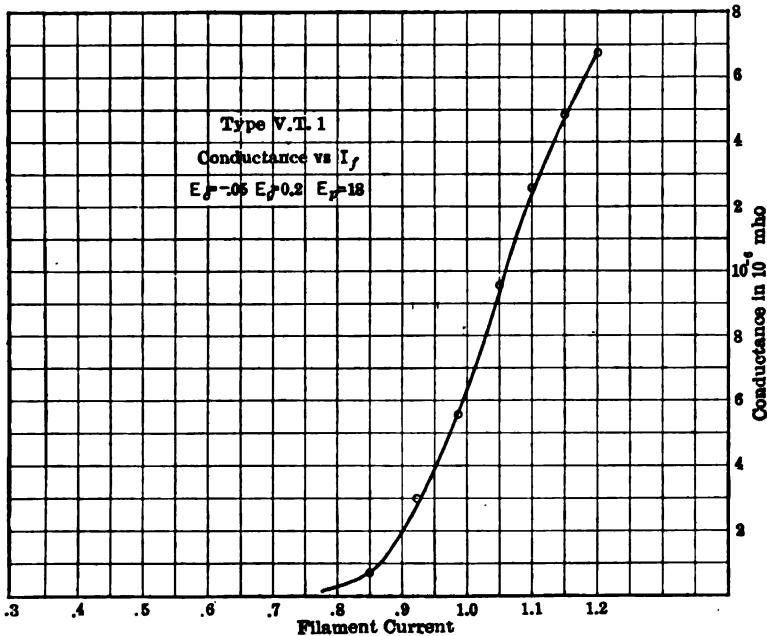

FIG. 52.—Variation of input circuit conductance with filament current.

With suitable values of C_2 and R_4 the bridge is balanced with S open, the values of C_2 and R_4 being recorded. When S is closed the balance is destroyed, due to the capacity and conductance of the tube input circuit; by properly decreasing C_2 and increasing R_4 the balance may be again obtained. The total capacity and conductance in the (4) arm must now be the same as when S was open, so that the capacity of the input circuit is at once obtained as the difference in the two settings of C_2 ; from the two values of R_4 the conductance of the input circuit can be readily calculated.

¹ "Some notes on vacuum tubes," Proc. I.R.E., Vol. 8, No. 3, June, 1920.

In Figs. 52-55 are shown the variation in the input circuit of a small detecting tube rated at 1.1 amperes filament current and 20-40 volts in the plate. Unless the tube is defective the conductance is practically zero until about 0.8 ampere is used for heating the filament. It then rises rapidly until with normal filament current the conductance is about 12 micromhos, showing an input resistance of about 80,000 ohms. The values of E_p and E_g used are noted on the curve sheet.

In Fig. 53 is shown the variation of the input conductance as plate voltage was varied; this decrease in conductance with increasing plate

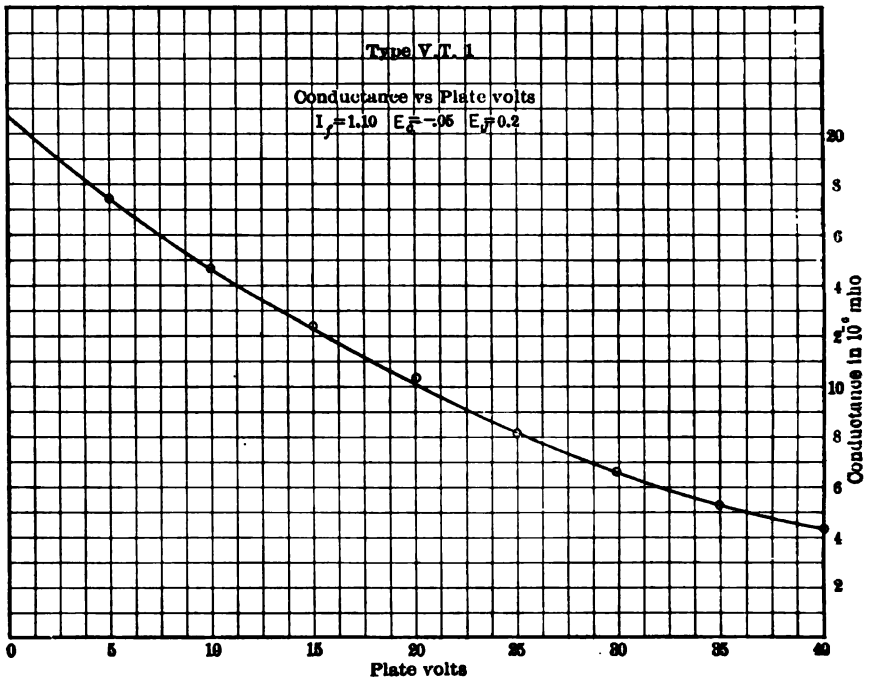

FIG. 53.—Variation of input circuit conductance with plate voltage.

potential could have been predicted from inspection of curves such as given in Fig. 29. In Fig. 54 is shown the variation in input conductance as the grid is made more negative, and in Fig. 55 is shown the effect of the magnitude of the alternating voltage impressed on the grid for testing.

It is evident from the four curves given above (which are all for the same tube) that if the input resistance of a tube is to be kept high the grid must at all times be negative (with respect to the negative end of the filament). For the tube the characteristics of which are given above, the grid should normally be negative about 0.5 volt more than the maximum value of the voltage to be impressed on the input circuit. The

resistance of the input circuit, as one component of the impedance of the input circuit, is of great importance if the tube is to be used as detector

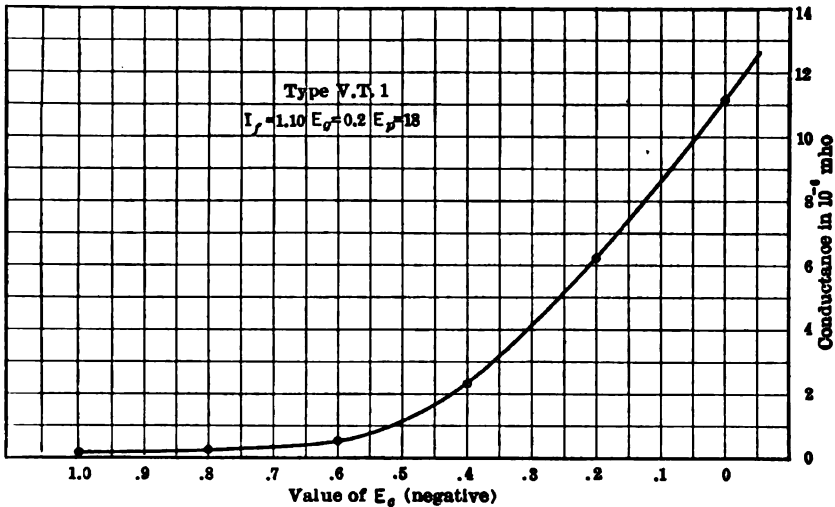

FIG. 54.—Variation of input circuit conductance with grid potential.

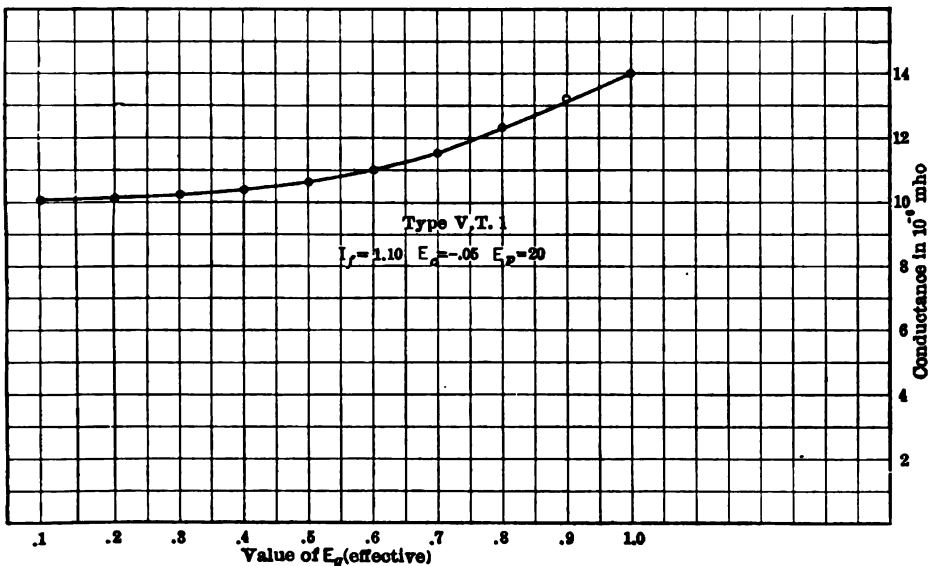

FIG. 55.—Variation of input circuit conductance with amplitude of voltage impressed on the input circuit.

or amplifier; if the tube is to be used as detector the input circuit resistance may very seriously affect the selectivity of the receiving circuit, because of its damping effect on the signal.

Capacity of the Input Circuit of a Three-electrode Tube.—It would seem as though the capacity (electrostatic) of a vacuum tube is so small as to be negligible, but such is far from the truth; the internal capacity of a tube may have very great effect on its operation, especially at high frequencies. There are three capacities to be considered, filament to grid, grid to plate, and grid to plate and filament when connected together. Part of the internal capacity is in the actual working parts of the tube, (filament, grid, and plate) but a lot of it is in the "lead in" wires, where they come close together in the seal. The base into which the tube fits also has an appreciable capacity.

In the accompanying table are shown the values of capacities for several types of tubes at present used, the tubes having the following ratings:

No.	Filament Current.	Plate Voltage	Plate Current.	Type of Filament.	Intended Service.
1	1.1	20-40	6×10^{-4}	Oxide	Detector and Amplifier
2	1.1	20-40	4×10^{-4}	Tungsten	Detector and Amplifier
3	1.30	130	7×10^{-4}	Oxide	Amplifier
4	1.75	350	5×10^{-2}	Tungsten	Power
5	1.35	300	4×10^{-3}	Oxide	Power
6	6.5	500	15×10^{-2}	Tungsten	Power
7	3.6	1000	25×10^{-2}	Tungsten	Power

The capacity of these tubes was measured in the bridge shown in Fig. 51, at 50 kilocycles and the results were as follows, the capacities being in 10^{-12} farads:

	No. 1.	No. 2.	No. 3.	No. 4.	No. 5.	No. 6.	No. 7.
Grid to filament, plate free	10.4	6.4	6.8	5.6	7.6	8.0	55.6
Grid to plate, filament free	14.4	4.4	7.6	3.0	8.4	8.0	22.0
Grid to plate and filament these being connected together	17.0	7.2	12.4	7.2	11.2	10.2	69.6

It will be noticed that the capacity of grid to plate and filament is not equal to the sum of the other two capacities; this is due to the "overlapping" of the fields of the grid-filament condenser and the grid-plate condenser. In Fig. 56 is shown a possible arrangement of the "seal-in" wires; the capacity from *G*, to *P* and *F* in parallel, involves, besides the capacity inside the tube, the capacity of the wires, *a*, *b*, *c*, and *d*. Such an arrangement will not give a capacity from *d* to *a*, *b*, and *c*, equal to the sum of the capacity from *d* to *c* and *b*, and that from *d* to *a*.

Now when a tube is being used, for whatever purpose, the plate and filament are connected together through the *B* battery and whatever external impedance is introduced in the plate circuit, and the input circuit is from grid to filament; it is therefore evident that the capacity of the input circuit is that between the grid as one plate of the condenser and the plate and filament connected together as the other plate of the condenser.

From the values given in the above table the input circuit capacity of the average tube is small enough to be neglected, and it very frequently has been, judging from the values of capacities used in certain amplifying sets.

But the values of capacity of the input circuit previously given are what the author has called the "geometrical capacity" of the input circuit; the actual capacity is very different from the values given.

In practically all circuits involving the use of a vacuum tube it is required to have an impedance of some sort in the plate circuit; this impedance may be a resistance, a choke coil, or the primary winding of a transformer, and the value of this impedance is generally of the same magnitude as the a.c. resistance of the plate circuit of the tube, R_p , or somewhat greater.

When such an impedance is used in series with the *B* battery the voltage on the plate E_p varies when the grid voltage E_g is varied and the amount of fluctuation in E_p is generally much greater than E_g . If an impedance

is used in the plate circuit, which is very high compared to the tube resistance, the fluctuation of E_p is nearly equal to $\mu_0 E_g$. It is always somewhat less than this value, and we put it equal to μE_g where μ lies between zero and μ_0 , depending on the plate circuit impedance.

Let us suppose a resistance, R , used in the plate circuit; it is at once

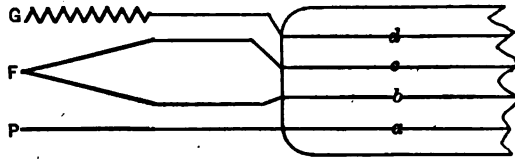

FIG. 56.—Possible arrangement of the wires of a three-electrode tube where they go through the press.

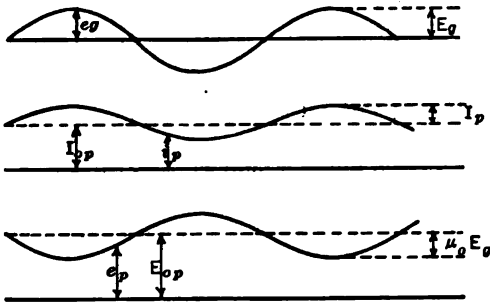

FIG. 57.—Forms of plate current and plate potential when a sine wave of voltage is impressed between the grid and filament. When the resistance in the plate circuit is very high the fluctuation in plate potential is nearly μ_0 times as great as the voltage impressed on the grid.

evident that as E_g increases, increasing thereby I_p , E_p must fall because of the increased value of $I_p R$. The forms of E_g , I_p and E_p are then as shown in Fig. 57; when the grid voltage rises (with respect to the filament) the plate voltage falls, and the actual plate voltage is represented by $(E_{op} - i_p R) = (E_{op} - \mu E_g \sin pt)$, where $E_g \sin pt$ is the voltage impressed between the grid and filament, i_p is the instantaneous value of $I_p \sin pt$, the resulting fluctuation in plate current, and E_{op} is the value of the plate voltage when E_g is zero.

We have then to consider the charging current taken by the grid

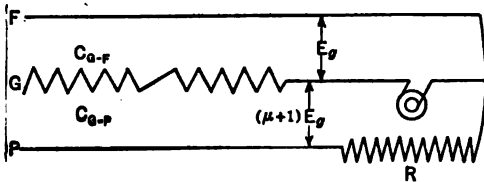

FIG. 58.—The circuit impressing the voltage E_g to the input circuit must furnish enough current to charge the condenser C_{G-F} to a voltage E_g and the condenser C_{G-P} to a voltage $(\mu + 1) E_g$.

when acted upon by an alternating voltage E_g , the condenser C_{G-F} being charged by voltage E_g and the condenser C_{G-P} in parallel, being charged to a voltage $(\mu + 1) E_g$, as shown in Fig. 58. The factor $(\mu + 1)$ occurs because when the grid voltage rises with respect to the filament, an amount E_g , the plate voltage falls, with respect to the filament, by an amount μE_g ; it therefore falls with respect to the grid, an amount $(\mu + 1) E_g$.

The amount of charging current, therefore, which must be furnished by the input circuit is given by

$$I = 2\pi f E_g (C_{G-F} + (\mu + 1) C_{G-P}),$$

from which the effective capacity of the input circuit is found to be

$$C_{\text{input}} = C_{G-F} + (\mu + 1) C_{G-P}. \dots \dots (10)$$

Thus the effective capacity of the input circuit is not only much greater than the geometrical capacity, but it varies with any factors which affect μ , the voltage amplification factor of the tube and circuit.

Due to the mutual capacity of the grid-filament condenser and grid-plate condenser, and also to the fact that the two voltages E_p and E_g are not exactly 180° apart, the capacity of the input circuit of a tube will actually be somewhat less than that predicted from Eq. (10).

This mutual capacity of the two condensers brings in another very interesting phenomenon: the field of the grid-plate condenser may so react on the grid-filament condenser as to give a voltage in this condenser in phase with the impressed e.m.f. of this condenser (i.e., the e.m.f. impressed on the input circuit) so as to give the input circuit a negative conductance. Such an effect would result in the plate circuit reacting

on the input circuit to augment any voltage impressed on the input circuit.

Using the bridge scheme illustrated in Fig. 51, the capacities and conductances of the input circuits of several of the tubes tabulated on p. 432 were measured at 50,000 cycles. In Fig. 59 are shown the capacity and

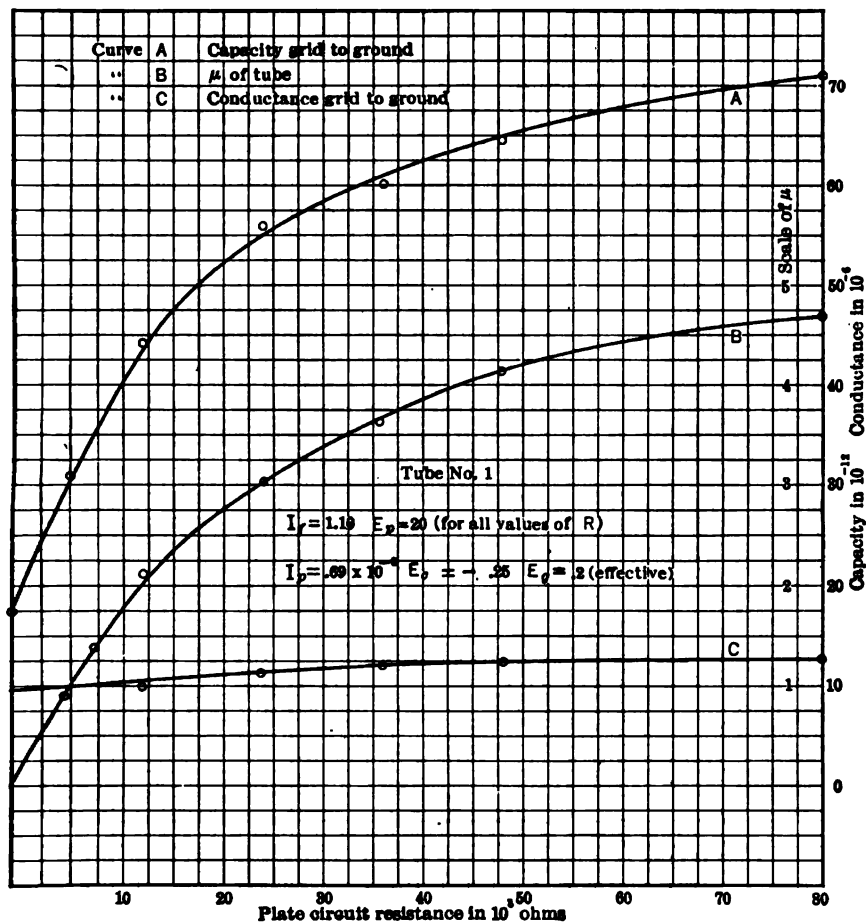

FIG. 59.—Capacity and conductance of tube V11 as the resistance in the plate circuit is varied; the μ of the tube is shown also, so that the dependence of capacity upon μ may be noted.

conductance of tube No. 1 with normal conditions of plate voltage, filament current, etc., as the external plate circuit resistance was varied; on the same curve sheet is shown the value of the voltage amplification factor of the tube for the various plate circuit resistances. It is seen that the capacity of the grid to-ground circuit (same as input circuit, because

the filament is generally grounded) increases from $17\mu\mu f$ (micro-microfarads) to $71\mu\mu f$ as the plate circuit resistance was increased from zero to 80 kilohms.

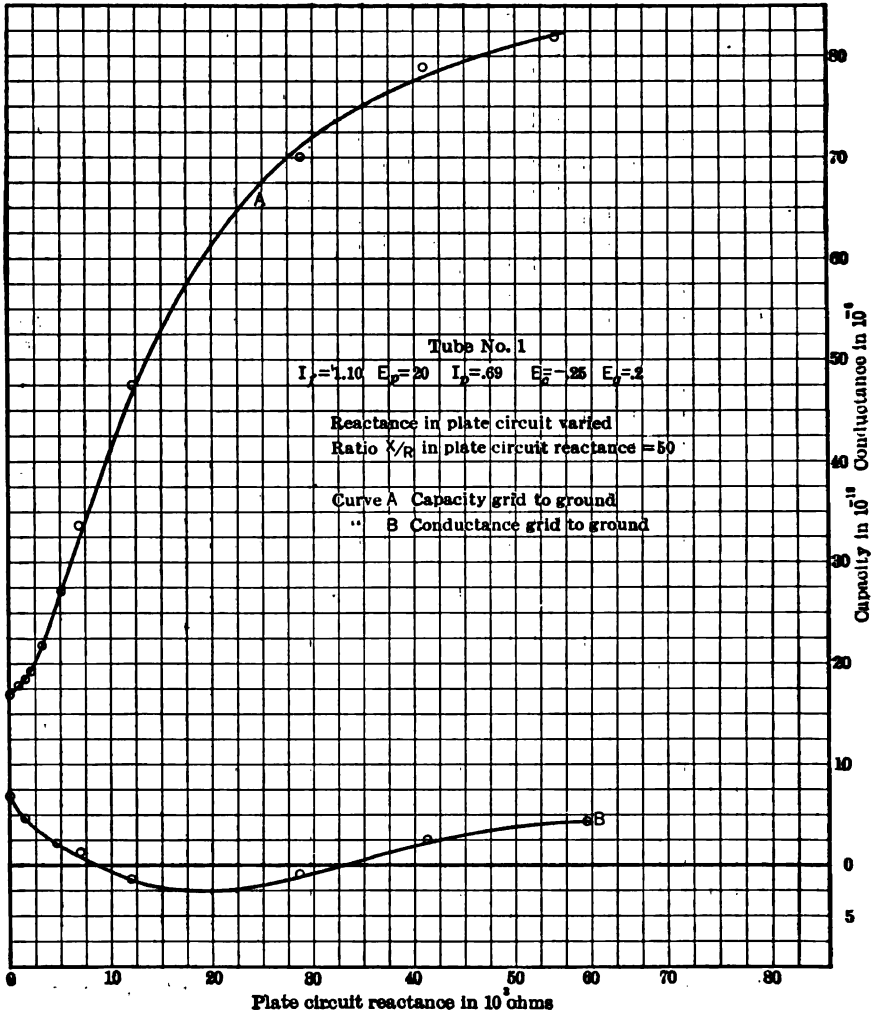

FIG. 60.—Capacity and conductance of the input circuit of detector tube **V11**, as the plate circuit reactance is varied. Note that the input conductance is positive throughout a certain range of the reactance.

As the capacity C_{G-F} of this tube was 10.4, and the capacity C_{G-P} was $14.4\mu\mu f$, and the value of μ is 4.65 for $R = 80$ kilohms, it might be expected that the input capacity would be equal to $(10.4 + (4.65 + 1)14.4)$

$=91.6 \mu\mu f$. The discrepancy between the measured and predicted values is undoubtedly due, in part, to the mutual capacity of C_{g-f} and C_{g-p} .

The conductance of the input circuit was positive for all values of plate circuit resistance and gradually increased as R was increased.

In Fig. 60 are shown the capacity and conductance for the same tube, the plate circuit impedance being an inductance with a reactance-resistance ratio between 25 and 50. In this case the increase in capacity is greater than when an equal amount of resistance was used in the plate circuit. Thus, with a reactance in the plate circuit of 50 kilohms the input circuit has a capacity of $82 \mu\mu f$, whereas a resistance of 50 kilohms gave an input capacity of only $65 \mu\mu f$. This difference in behavior of reactance and resistance is due to the fact that the μ of the circuit is greater in one case than in the other, as will be explained later.

That any capacity present between the grid and plate, and which is not in the field of the grid-filament condenser, is increased by the factor $(\mu+1)$ was proved by actually connecting a capacity of $20 \mu\mu f$ across the plate-grid terminals of the tube and noting the increase in the effective capacity of the input circuit, the μ of the circuit being 4.2. The capacity of the input circuit increased by $102 \mu\mu f$, whereas calculation would make it increase by $(4.2+1) \times 20$, or $104 \mu\mu f$.

The conductance of the input circuit of the tube was negative throughout a certain range of plate circuit reactance, thus indicating transfer

of power from the plate circuit back to the grid circuit, with no other coupling between the grid and plate circuits than what existed in the tube itself. This curve shows that the three electrode tube is not inherently a "one-way repeater," as has been commonly supposed; the output circuit does control the input circuit to an appreciable extent, sufficient in fact to maintain the tube in operation as a generator of alternating-current power when it is connected to the proper circuit. If the grid circuit and plate

circuit are each tuned to the same frequency, as indicated in Fig. 61, the tuning condensers are sufficiently small (and the coils fairly efficient), the coupling of the two circuits inside the tube may be sufficient to maintain the tube in the oscillating state, alternating currents flowing in circuits L_2C_2 and L_1C_1 .

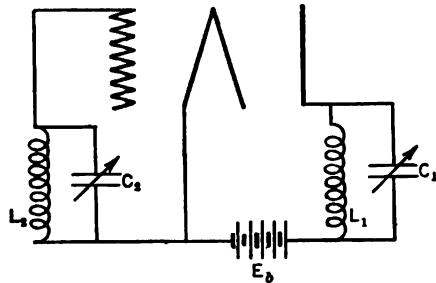

FIG. 61.—In such a circuit as this, with efficient coils used in both circuits, with suitable values of the capacities the tube will maintain itself in an oscillatory state, due to the negative conductance as shown in Fig. 60.

In Figs. 62-66 are shown the characteristic curves of some of the other tubes tested. It is seen that the same general shape holds for all three electrode tubes, the difference being one of degree only. The capacity of the grid-ground circuit of the ordinary tube, when it is operating with the normal amount of resistance (or reactance) in the plate circuit, is from five to ten times as much as the geometrical capacity of of

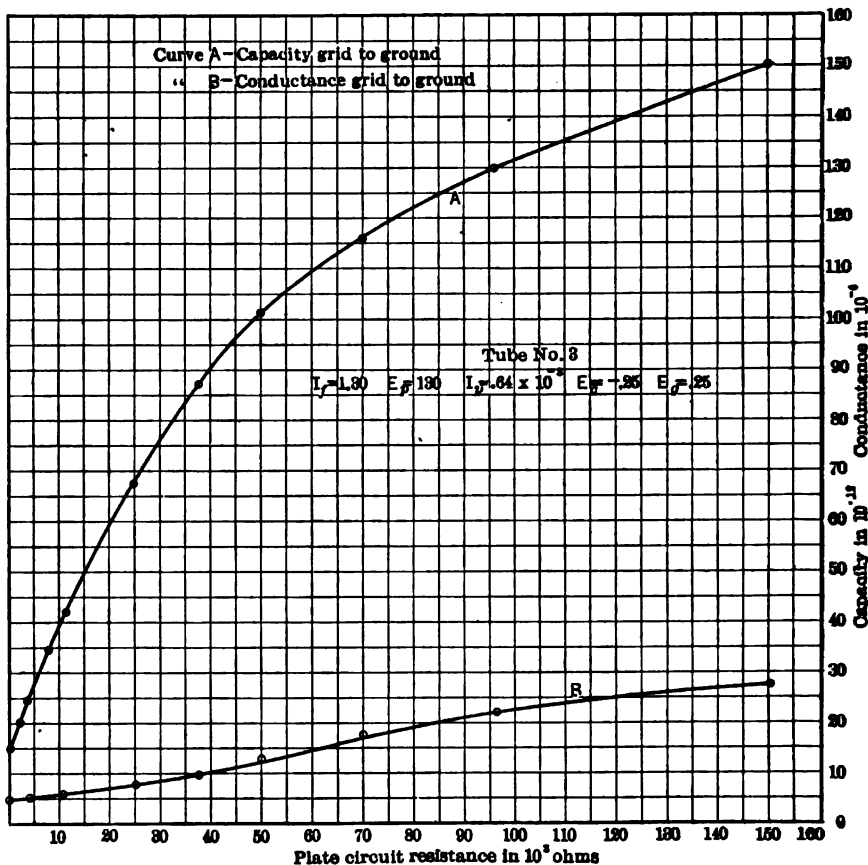

FIG. 62.—Variation in conductance and capacity of the input circuit of a telephone repeater tube as plate circuit resistance is varied.

the circuit, and the amount of this increase is controlled principally by the capacity between the grid and plate.

As has been pointed out the characteristics of the input circuit of a tube depend upon the relative phases of the input voltage and the voltage variation between the plate and filament. As this phase relation will evidently depend upon the kind and amount of reactance in the external

portion of the plate circuit we may expect the input characteristics to vary with the input frequency because this will determine the reactance, other things being constant. This effect has been investigated theoretic-

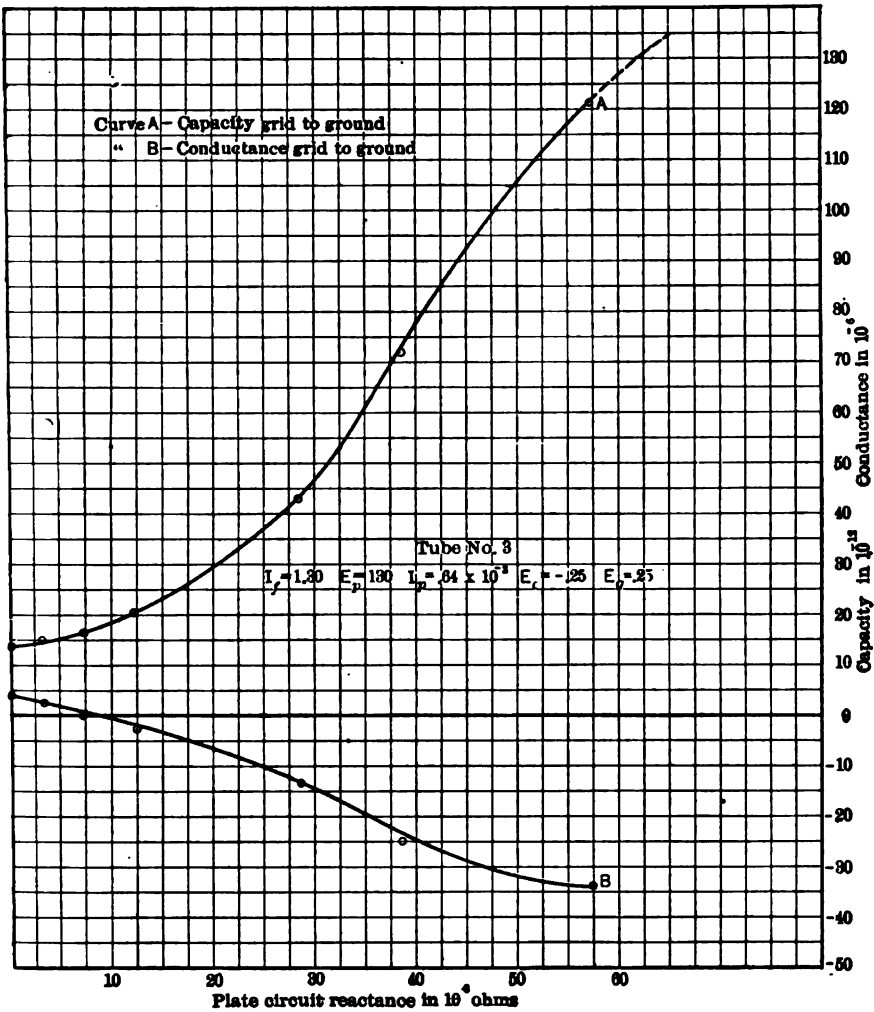

Fig. 63.—Curves similar to those of Fig. 62, the plate circuit having a variable reactance instead of resistance.

ally by Ballantine,¹ who shows that for resistive plate circuit the effective input capacity decreases with an increase in frequency and the input conductance increases with an increase in frequency. For reactive plate circuit the effect of frequency may be to either decrease or increase the

¹ Stuart Ballantine, "The Thermionic Amplifier," Physical Review, Vol. XV, No. 5.

input circuit constants, depending upon the amount of the reactance used.

Operation of Three-electrode Tube as Detector of Damped-wave Signals. Grid Condenser. Leak Resistance. Normal Grid Potential.—Any detector of high-frequency currents must in some way cause low-frequency pulsations of current through the telephones when the

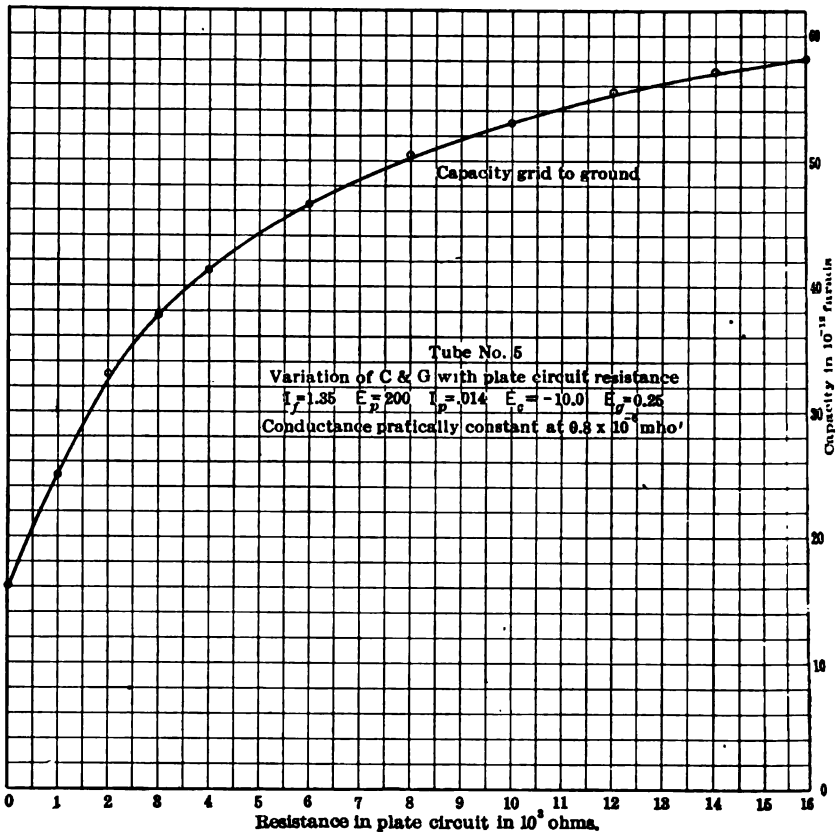

FIG. 64.—Variation in conductance and capacity of the input circuit of a small power tube (VT_2) as plate circuit resistance is varied.

device itself is actuated by high-frequency currents. The frequency of the low-frequency pulsations is fixed by the number of damped-wave trains arriving at the antenna per second in case of reception of a signal from a spark station, and is fixed by local conditions when receiving from a continuous wave station. The case we shall consider in this section is for spark signals only; damped-wave trains of the form shown in Fig. 67 are to be detected by the three-electrode tube. The time between

wave trains *A* may be from .005 to .0005 second; the duration of a wave train *B* may be from .00001 to .001 second, and the time of one cycle, *C*, may be from .0000001 to .00003 second.

The function of the detector is to produce in the telephone, fluctuation of current, of frequency fixed by the time *A*, as large as possible with a given amplitude of signal voltage. The scheme of connections used when

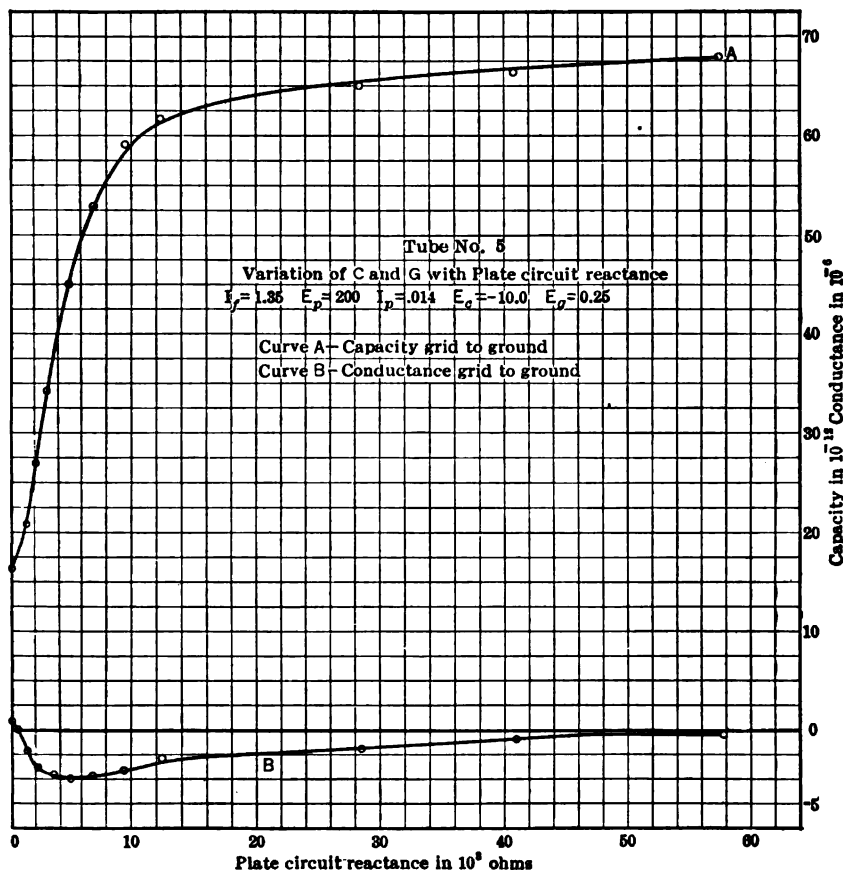

Fig. 65.—Curves similar to those of Fig. 64, the plate circuit having a variable reactance instead of resistance.

no condenser is inserted in series with the grid of the tube is shown in Fig. 68; the ground terminal of the input circuit is generally connected to the negative end of the filament or to some point in the circuit at a lower potential than the negative end of the filament. This is possible by either of the two schemes sketched in Fig. 69; in (a) a resistance *R* is inserted in the negative filament wire and the potential of point *A* is

thus lower in potential than the negative end of the filament by an amount $I_f R$, generally one volt or less, whereas in (b) a battery C is inserted in series with the input circuit to properly lower the grid potential. In case a careful adjustment of this potential is desired (generally not neces-

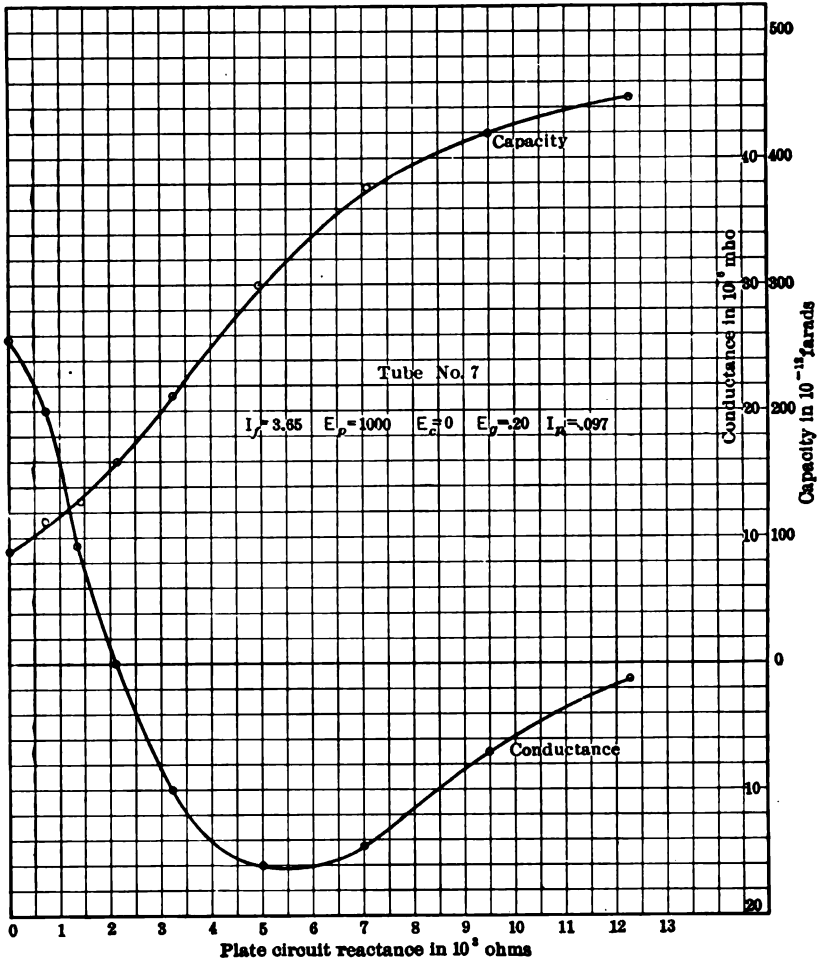

FIG. 66.—Variation of conductance and capacity of the input circuit of a large power tube as plate circuit reactance is varied.

sary) the grid may be connected to battery C through a suitable potentiometer connection.

The reason for maintaining the grid at a negative potential is evident in looking at the input circuit conductance curves previously given; suppose the conductance of the grid circuit is 10^{-5} mhos, and the signal being

received is 600 meters, the tuning condenser C_1 (Fig. 68) being set at $200 \mu\text{mf}$. A conductance of 10^{-5} mhos is equivalent to a shunt resistance

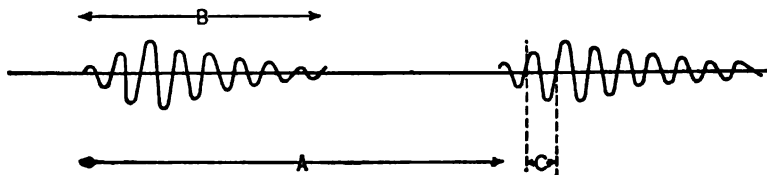

FIG. 67.—Conventional representation of part of a damped wave signal.

of 10^5 ohms around condenser C_1 , and this is approximately equivalent (by Eq. (30) Chapter II) to a resistance of 25.4 ohms in series with C_1 . But such a large resistance would materially interfere with the selectivity of the receiving circuit, in fact would make it practically useless if there was much interference; the resistance of the receiving circuit itself would be only a few ohms, perhaps five.

The characteristics of the tube being as shown in Fig. 70, the normal grid potential being E_{0g} , the question is how much will the telephone current (Fig. 68) change during the time one of the wave trains of Fig. 67 is actuating the grid. By actually plotting the values of plate current for each grid potential we get the curve of plate current shown by i_p in Fig. 70, while the grid potential is undergoing the changes indicated by the curve e_g .

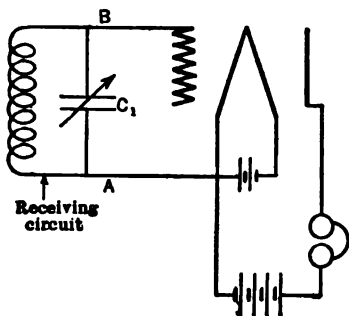

FIG. 68.—Connection scheme for using a three-electrode tube as detector, without use of a condenser in series with the grid.

The increase in the average value of the plate current is indicated by the dotted line in Fig. 70, and this average increase, during the time the grid is being excited by a wave train, is what determines the response of the telephone diaphragm. Such a use of the static characteristic of the tube is permissible only if the receiving circuit is so arranged that, as the signal is received, the plate potential does not appreciably vary; this condition implies an external plate circuit of impedance which, compared to the internal plate resistance, is negligible for the frequency of the signal.

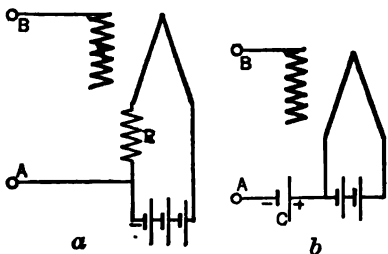

FIG. 69.—Two schemes for maintaining the average potential lower than the lowest potential point of the filament.

pedance which, compared to the internal plate resistance, is negligible for the frequency of the signal.

The author arranged a tube circuit so that its input voltage and plate current could be recorded on an oscillogram, when a damped sine wave of about 100 cycles (having the general form of an actual wave train from a highly damped spark station) was impressed on the input circuit; some of the films obtained are presented herewith. In Fig. 71 are shown the input voltage, plate current and telephone current when the grid was

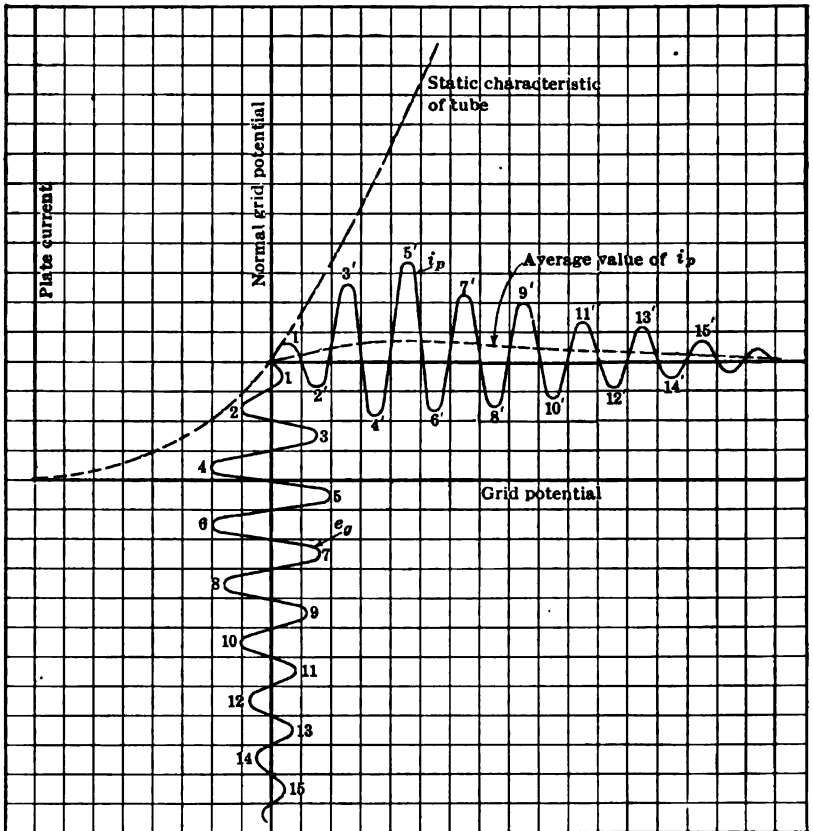

FIG. 70.—Analysis of the action of the three-electrode tube as detector of damped wave signals; assuming a certain variation in grid potential the resulting fluctuation in plate current can be plotted from the plate current, grid potential curve of the tube.

made normally 2.5 volts negative with respect to the filament. A large capacity condenser was shunted around the coil representing the telephone of an ordinary receiving set so that the "high-frequency" current was not forced to flow through this coil. This condenser charged up during the first part of the wave train more rapidly than it discharged through the coil, so that its charge increased. Then as the wave train



FIG. 71.—Oscillogram showing rectification without grid condenser; these actual curves agree exactly with curves predicted as in Fig. 70. The frequency of the artificial signal used in getting this film was about 100 cycles per second.

was reduced to zero by damping, the fluctuations in plate current ceased and the condenser continued to discharge through the coil; this action caused the current through the coil to lag somewhat behind the wave train impressed on the grid, as is evident from the film.

The signal used in getting this film, as well as those to follow, was much stronger than an actual radio signal; the change in "telephone" current in Fig. 71 is about 5 milliamperes, whereas actually a fairly strong radio signal does not produce a change in the telephone current of more than a few microamperes. Figs. 70 and 71 show the rectifying action of a tube

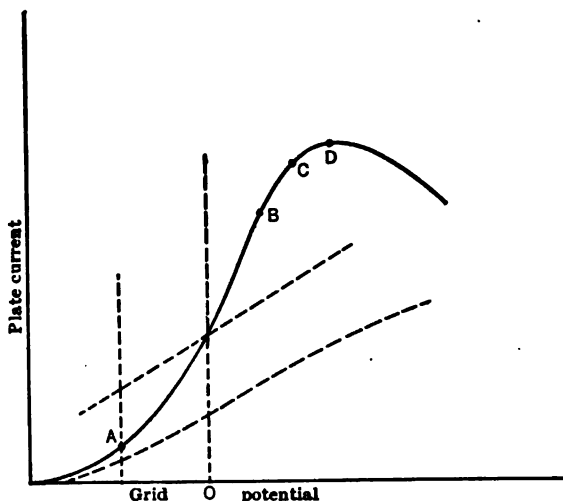

FIG. 72.—Form of the plate current, grid potential curve of the tube used in getting the films of Figs. 71, 73, 74, 75.

brought about by the increase in plate current being greater than the decrease; the grid was put as such a negative potential that the tube was operating well down on its characteristic about as indicated at A, Fig. 72.

The grid potential was then made positive sufficiently to rectify by giving a greater decrease then increase in plate current; Figs. 73, 74, and 75 show the forms of potentials and currents when putting

sufficient positives potentials on the grid to bring it to points B, C and D (Fig. 72) respectively. It is to be noted in the film shown in Fig. 75 that at the highest positive grid potentials the plate current had actually decreased; the amount of current taken by the grid was sufficient to bring about a decrease in plate current. In each film the zero lines of potential and currents are shown.

An elementary analysis shows the efficiency of a tube for the purpose of detector, (i.e., its rectifying power) depends largely upon the radius of curvature of the plate-current grid-potential characteristic. We put

$$I_p = f(E_g)$$

With no signal $I_{op} = f(E_{og})$ and when the signal voltage ΔE_g is impressed on the grid

$$\begin{aligned} I_{op} + \Delta I_p &= f(E_{og} + \Delta E_g) \\ &= f(E_{og}) + \Delta E_g \frac{dI_p}{dE_g} + \frac{\Delta E_g^2}{2} \frac{d^2 I_p}{dE_g^2} + \dots \end{aligned}$$



FIG. 73.—Rectifying action of tube adjusted for normal grid potential as at B, Fig. 72.



FIG. 74.—Rectifying action of tube adjusted for normal grid potential as at C, Fig. 72.



FIG. 75.—Rectifying action of tube adjusted for normal grid potential as at D, Fig. 72. Note that for the highest value of grid potential occurring during the application of the signal the plate current actually decreases.

Then we have as an approximation

$$\Delta I_p = \Delta E_g \frac{dI_p}{dE_g} + \frac{\Delta E_g^2}{2} \frac{d^2 I_p}{dE_g^2} \dots \dots \dots (11)$$

If ΔI_p is periodic the average value of the first term $\Delta E_g \frac{dI_p}{dE_g}$ is zero so that the average value of ΔI_p becomes equal to the average value of $\frac{\Delta E_g^2}{2} \frac{d^2 I_p}{dE_g^2}$. Now, if ΔE_g is a sine function of time of the form, $E \sin pt$, we have for the average value of the change in plate current

$$\Delta I_p = \frac{d^2 I_p}{dE_g^2} \frac{1}{2T} \int_0^T E^2 \sin^2 pt d(pt) = \frac{E^2}{4} \frac{d^2 I_p}{dE_g^2} \dots \dots (12)$$

The increment in plate current therefore varies with the square of the signal strength, a defect practically all rectifying devices have. At a point of inflection of the $I_p - E_g$ curve, $\frac{d^2 I_p}{dE_g^2} = 0$ and the rectifying power is lost. The increment in plate current will be negative or positive according to the sign of $\frac{dI_p^2}{dE_g^2}$, as illustrated in the foregoing films.

It might seem that the best point to operate on the plate current curve is where the radius of curvature is greatest, but this is not quite so. If z = radius of curvature,

$$z = \frac{\left(1 + \frac{dI_p}{dE_g}\right)^{3/2}}{\frac{d^2 I_p}{dE_g^2}}$$

so that

$$\frac{d^2 I_p}{dE_g^2} = \frac{\left(1 + \frac{dI_p}{dE_g}\right)^{3/2}}{z} \dots \dots \dots (13)$$

It is evident that if the radius of curvature is not changing rapidly the value of $\frac{dI_p}{dE_g}$ has importance in determining the rectifying power, the greater the slope the greater is the rectifying action.

As shown in Figs. 71 and 74 there are two points where the detecting power is about the same, one with negative grid and one with positive grid (*A* and *C* of Fig. 72). The negative grid is to be preferred to the positive, because of the high conductance of the input circuit with a positive grid, and consequent excessive damping of the receiving circuit as explained on p. 443.

The curve of Fig. 70 is obtained by maintaining plate voltage constant; if there is a high resistance or reactance in series with the *B* battery, the

effect is to straighten out the characteristic curve, and so decrease the value of $\frac{dI_p^2}{dE_g^2}$ throughout the whole extent of the curve as shown by the dotted line curve in Fig. 72. The reactance of a pair of phones, for radio frequency current may be very high, hence the effect just mentioned might exist; to eliminate it a condenser should be used in shunt with the phones, thus furnishing a low impedance path for the high-frequency current and so maintaining the plate voltage essentially constant as the grid potential fluctuates. In Figs. 71, 73, 74, and 75, a condenser "by-pass" around the phones was used, its impedance for the frequency used was very much lower than that of the phones, so that practically all of the high-frequency pulsations took place through the condenser, the telephone current changing only as the average value of the plate current decreased.

Effect of Grid Condenser.—The average three-electrode tube will give better rectifying action if the curvature of the I_p-E_g curve is used instead of that of the I_p-E_g curve. The use of a suitable condenser in series with the grid enables us to utilize the curvature of the grid current curve; the ordinary connection is shown in Fig. 76, the resistance R being about one megohm for the average tube. It is called the "leak" resistance and its function will be explained shortly. The potential of the grid (when no signal is coming in) depends upon the value of the leak resistance, the form of the I_p-E_g curve, and upon the potential of the point to which the ground end of R is connected.

The form of the I_p-E_g curve for two typical detecting tubes is shown in Figs. 77 and 78; the curves are shown for comparatively large change in the grid potential, much larger than ever occurs when the tube is being used. Such tubes as those used in getting the curves of Figs. 77 and 78 would give a readable signal in the telephones with a change of grid potential of perhaps 0.03 volt. As would naturally be supposed, the free grid potential is that for which the grid current becomes zero in the graphs; when free the grid potential will decrease to such a potential that no more electrons tend to accumulate on it.

When using such tubes in the connection scheme shown in Fig. 76 the first point to be examined is the potential at which the grid will set itself when no signal is being impressed on the grid. It is common practice to connect the end of resistance R to the positive end of the filament, and we will so assume it in finding the normal grid potential. In Fig. 79 is shown the grid current (with enlarged scale for I_g); it is supposed that

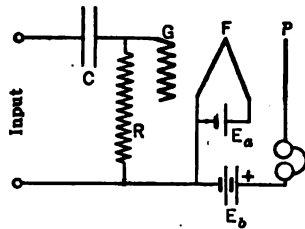

FIG. 76.—Arrangement of three-electrode tube for detection by use of a condenser in series with the grid.

the IR drop in the filament is 2 volts. The straight line AB is drawn through the point $E_g = +2$ and at an angle such that $\cot \phi = R$. The point C , where this line intersects the $I_g - E_g$ curve, fixes the normal grid potential E_{og} . This follows from the fact that whatever current flows to the grid must return to the filament (positive end) through the resistance R and so cause in this a drop of $I_g R$; furthermore this drop, added to the normal grid potential E_{og} , must give a voltage equal to $+2$ volts, the potential of the positive end of the filament.

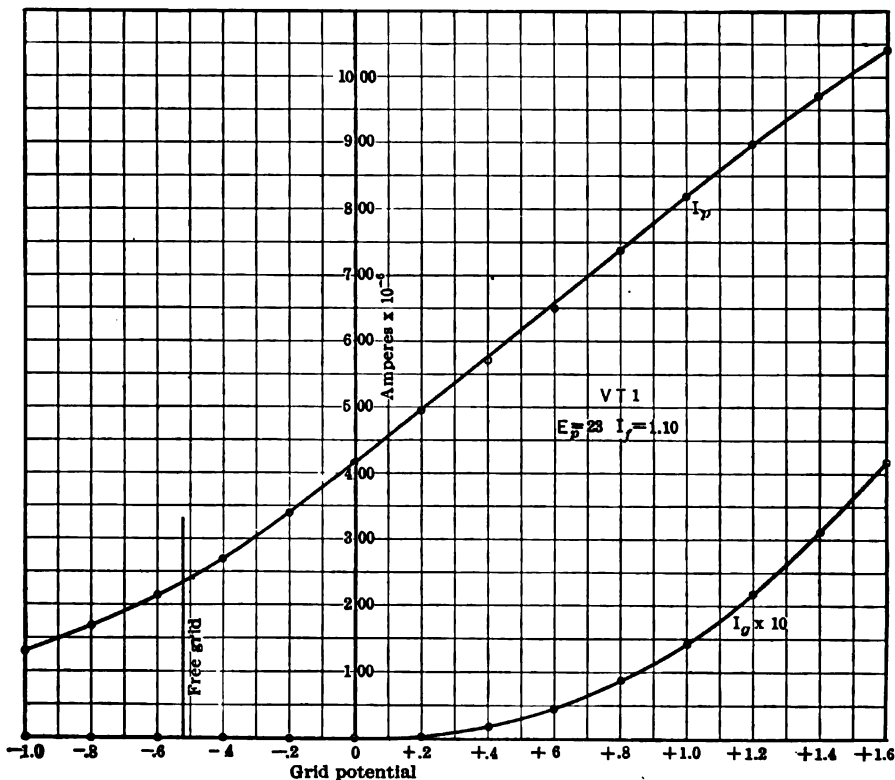

Fig. 77.—Plate current and grid current curves for a VT1 detector tube.

If the leak resistance is 10^6 ohms $\cot \phi$ must be 10^6 when the scales of potentials and currents are in corresponding units as, e.g., volts and amperes. As the scale of current in Fig. 79 is 10^5 smaller than that of potential, the angle ϕ in this diagram is so drawn that $\cot \phi = 10$. If a leak resistance of only 5×10^5 ohms were used, the normal value of grid potential E_{og} would be as shown at C' , obtained by making $\cot \phi = 5$.

When an alternating e.m.f. is now impressed on this input circuit, the grid will start to fluctuate about its normal value of potential, E_{og} ;

its potential will be increased and decreased from the value E_{0g} equally for the first cycle. Due to the form of the $I_g - E_g$ curve, however, the increase in current, when the impressed e.m.f. is positive is greater than the decrease in current when the impressed e.m.f. goes negative, and this rectifying action tends to increase the number of electrons accumulated on that side to the condenser C (Fig. 76), which is connected to the grid. But this accumulation of electrons must depress the potential of the grid

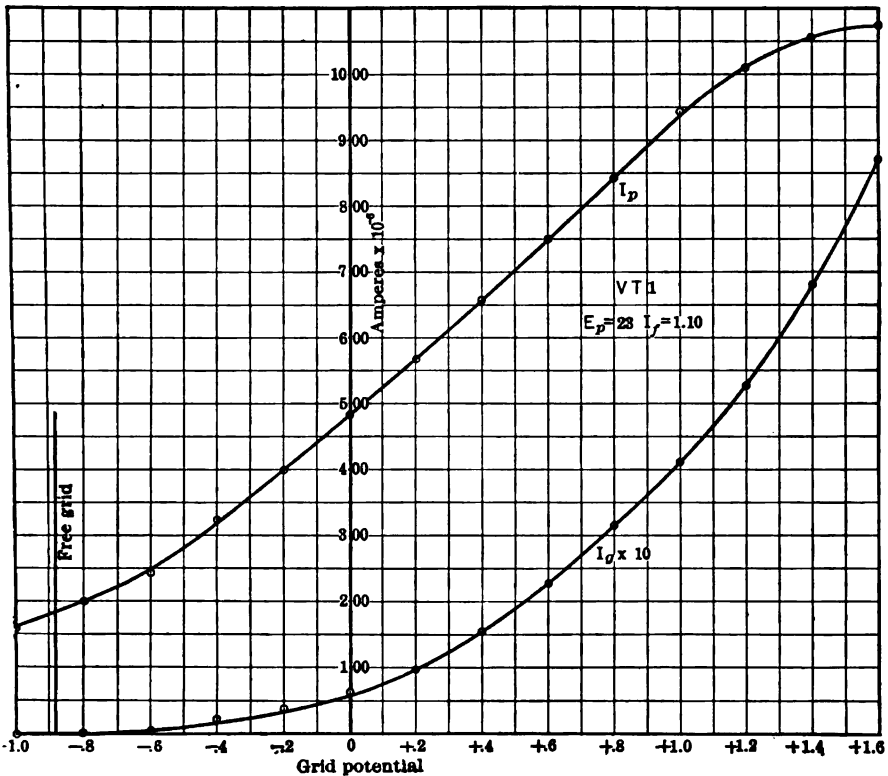

FIG. 78.—Curves similar to those of Fig. 77 for a supposedly identical tube.

below its normal value, and so cause a decrease in the plate current. The amount of this decrease in plate current for a given alternating e.m.f. impressed on the input circuit, is a measure of the efficiency of the tube as a detector, so we shall investigate this point more fully.

Before starting this analysis it is well to point out that whereas a tube may detect by either an increase or decrease in plate current when no grid condenser is used, with the grid condenser a signal always produces a decrease in plate current, never an increase.

At the end of the wave train the grid condenser C (Fig. 76) will be

charged (negatively on the side connected to the grid) and this charge must leak off before the next wave train arrives, otherwise the tube will not respond to a signal as well as it should. The time taken for the

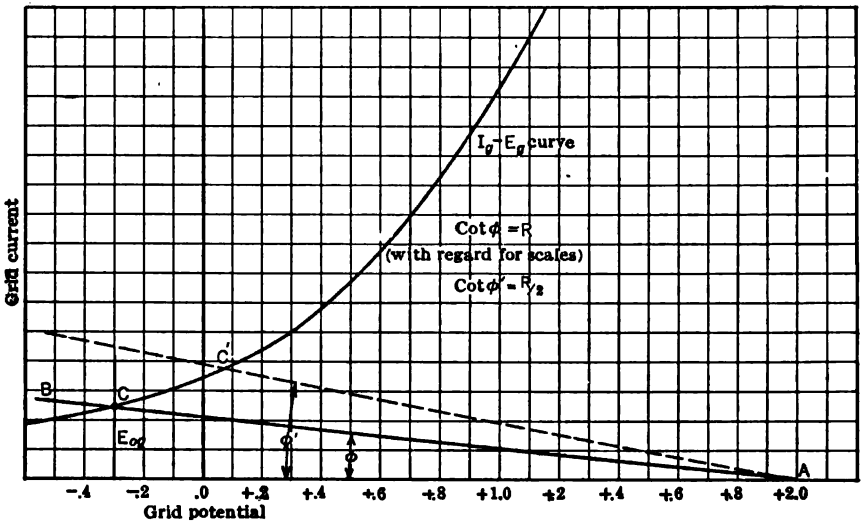

FIG. 79.—A diagram for determining the normal grid potential of a tube connected as in Fig. 76; the leak resistance is supposed connected to the positive end of the filament and the IR drop in the filament is assumed as 2 volts.

charge to leak off from C depends upon the magnitude of C and the leak resistance R , in fact, can be calculated directly from these two quantities. In a time equal to RC , 63 per cent of the

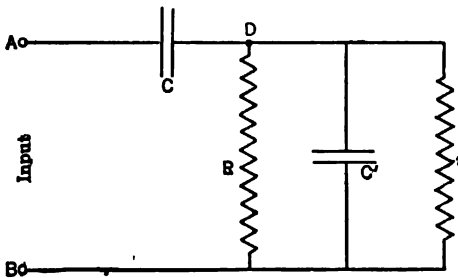

FIG. 80.—A circuit equivalent to the input circuit of a detector tube; C' represents the effective capacity of the input circuit and $1/r$ represents the conductance of the input circuit. These quantities for different tubes were shown in Figs. 59-66.

charge will have leaked off; if the tube is to operate efficiently as a detector therefore the product RC must be small compared to the time between the successive wave trains of the signal.

On the other hand, C must be as large as feasible and R also must be large, otherwise a large fraction of the signal voltage will be used up in C , and thus be of no service in producing sound in the telephones. The input circuit of Fig. 76 may be represented as in Fig. 80; C is the external condenser used in series with the grid, C' is the capacity of grid-to-ground

inside the tube and r is the leakage inside the tube itself. The values of C' and $\frac{1}{r}$ (tube conductance) for various tubes were given in Figs. 59-66; the impedance between D and B , Fig. 80, is therefore calculable when R is given. Designating this impedance by Z_t , we then find that the voltage impressed on the grid of the tube is equal to the input voltage (across points $A-B$, Fig. 80) multiplied by the fraction $\frac{Z_t}{(Z_t + \frac{1}{\omega C})}$ the

addition and division being carried out vectorially.

In addition to the features just analyzed we must remember that the impedance between points $A-B$ is to be kept high as this input circuit is connected directly across the tuning condenser of the receiving set. With the detecting tubes commonly used (characteristics about like tube No. 1, page 432) it seems that $C = 5 \times 10^{-10}$ and $R = 10^6$ give the best results. For tubes having smaller internal capacity lower values of C and higher values of R are better suited; thus the detecting tube shown at J , Fig. 21, is generally used with $C = 4 \times 10^{-10}$ and $R = 4 \times 10^6$.

Analysis of Detector Action with Grid Condenser.—Let the voltage between the grid and the negative end of the filament (which we call zero potential) be a , then

$$I_{og}R + E'_{og} = a \quad \dots \dots \dots (14)$$

where I_{og} and E_{og} are the normal values of grid current and potential respectively, when no signal is being impressed.

When a signal is impressed on the input circuit, the grid is acted upon by a voltage $E \sin pt$; the grid current will pulsate in value about its normal value, but owing to the form of the $I_g - E_g$ curve the increase in grid current is greater than the decrease, so that there is an average increase in the grid current which is equal to $\frac{E^2}{4} \frac{d^2 I_g}{dE_g^2}$ as was previously proved for the plate current—see Eq. (12). This increase in grid current must pass through the resistance R , so that the equation for grid potential when the signal is being impressed is,

$$I'_g R + \frac{E^2}{4} \frac{d^2 I_g}{dE_g^2} R + E'_g = a \quad \dots \dots \dots (15)$$

Also we have E'_g , being the new average value of grid potential when signal is being impressed on the grid, and I'_g corresponding to E'_g (see Fig. 81),

$$I'_g = I_{og} - \Delta E_g \frac{dI_g}{dE_g}$$

so that from Eqs. (14) and (15), we may get the relation,

$$\left(I_{og} - \Delta E_g \frac{dI_g}{dE_g} \right) R + \frac{E^2}{4} \frac{d^2 I_g}{dE_g^2} R + E'_g - E_{og} - I_{og} R = 0.$$

By combining terms, we get

$$I_{oo}R - \Delta E_g \frac{dI_p}{dE_g} R + \frac{E^2}{4} \frac{d^2 I_p}{dE_g^2} R - \Delta E_g - I_{oo}R = 0.$$

or

$$\Delta E_g \left(1 + R \frac{dI_p}{dE_g} \right) = \frac{E^2}{4} \frac{d^2 I_p}{dE_g^2}.$$

So that

$$\Delta E_g = \frac{E^2}{4} \frac{\frac{d^2 I_p}{dE_g^2}}{\frac{1}{R} + \frac{dI_p}{dE_g}} \dots \dots \dots (16)$$

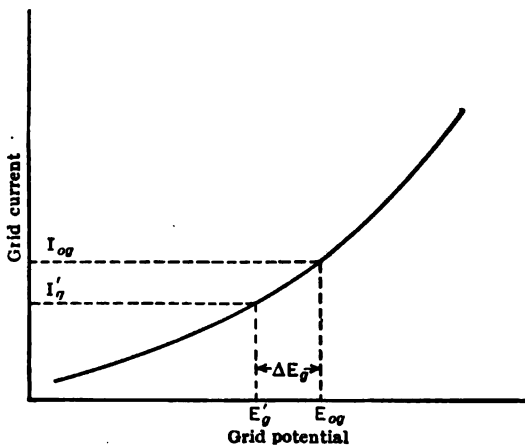

FIG. 81.—Change in grid potential due to the increased drop in the leak resistance when a signal is impressed on the tube.

If R is small compared to $\frac{dE_g}{dI_p}$, this simplifies to

$$\Delta E_g = \frac{E^2}{4} \frac{\frac{d^2 I_p}{dE_g^2}}{\frac{dI_p}{dE_g}} \dots \dots \dots (17)$$

The decrease in plate current caused by this drop in grid potential depends upon the shape of the $I_p - E_g$ curve, or $\frac{dI_p}{dE_g}$. The real measure of the detecting efficiency of a tube is therefore,

$$\Delta I_p = \Delta E_g \frac{dI_p}{dE_g} = \frac{E^2}{4} \frac{\frac{d^2 I_p}{dE_g^2}}{\frac{dI_p}{dE_g}} \frac{dI_p}{dE_g} \dots \dots \dots (18)$$

It must be remembered that E is not the voltage impressed upon the input circuit (i.e., the signal voltage) but something less due to the drop

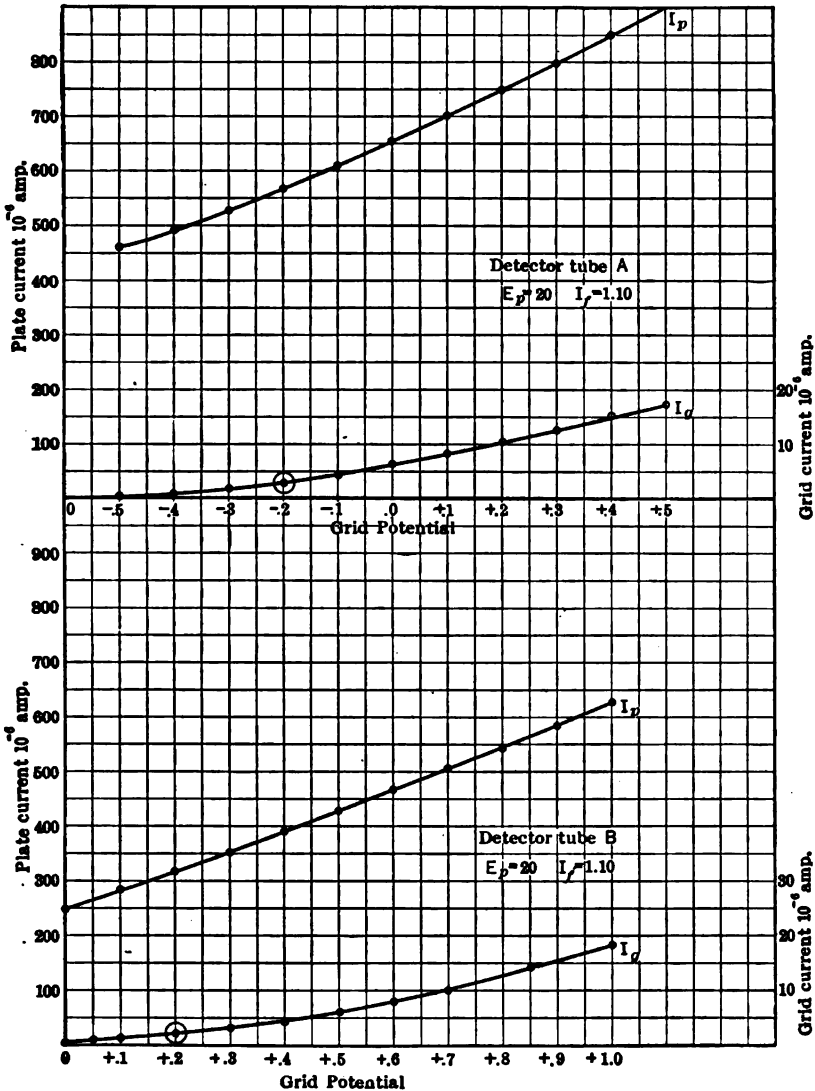

Fig. 82.—Characteristic curves of two detector tubes. Using Eq. (18) it is found that to change the average plate current by one microampere requires a signal voltage of .059 volt for tube A and .052 volt for tube B. Without grid condensers the tubes require about three times as much grid voltage for the same change in plate current.

in the grid condenser. The solution in Eq. (18) supposes the signal has persisted long enough for the steady state to be reached; if a damped sine

wave is impressed, the detection efficiency will depend upon the decrement, size of grid condenser, etc., as analyzed on p. 461. The solution obtained in (18) also neglects the difference in value of $\frac{d^2 I_p}{dE_g^2}$ at the two grid voltages E_{og} and E'_g .

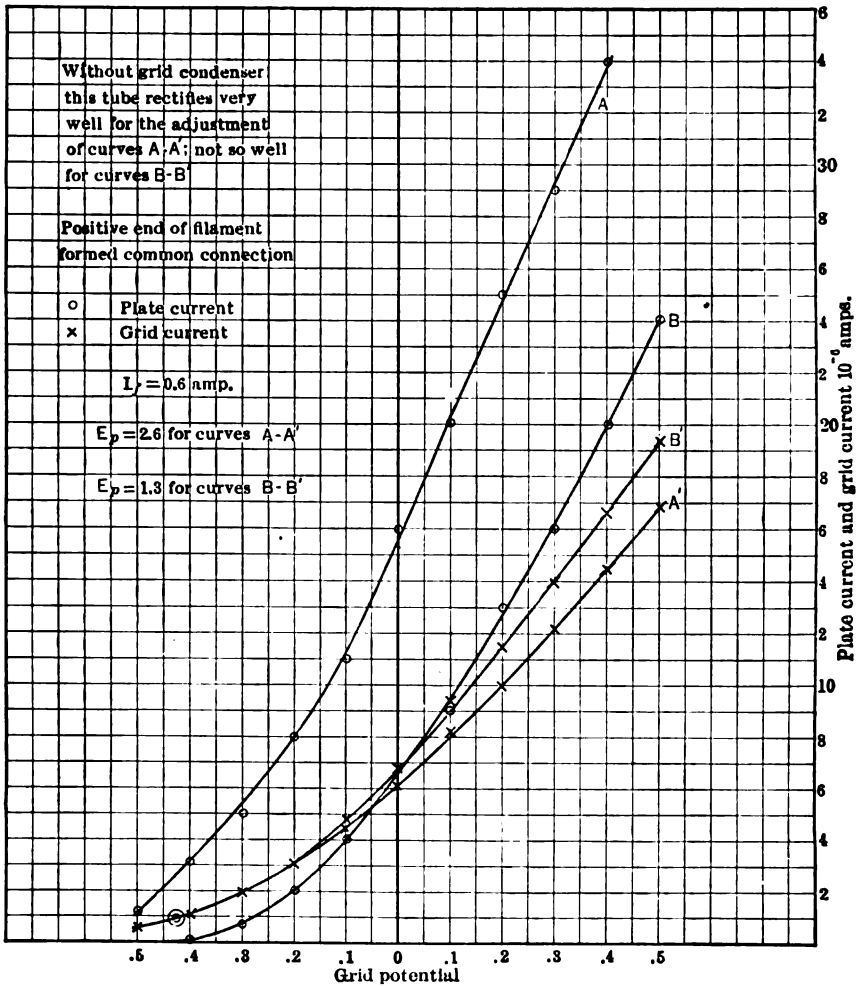

FIG. 83.—Even with very low plate voltage and filament current some tubes detect very well; with half normal filament current and a plate potential of only 1 or 2 volts this oxide coated tube requires only about .3 volt signal to give one microampere change in plate current.

In Fig. 82 are shown the grid and plate currents of two detecting tubes such as were used by the Signal Corps. If no grid condenser were used with these tubes we find (using Eq. (12)) that to produce an increase

tive end) curves of I_p and I_g were obtained as in Fig. 83. With no grid condenser and $E = 2.6$ volts, the detecting action was much better than might be expected with filament current and plate voltage so far away from their rated values. By Eq. (12) for curves *A* an input voltage of 0.28 is required to give a charge of 1 microampere in the average value of the plate current and for curves *B* a voltage of 0.34 was required.

In Fig. 84 is shown the great difference in the form and magnitude of I_p and I_g when the junction of grid-filament circuit is changed from the

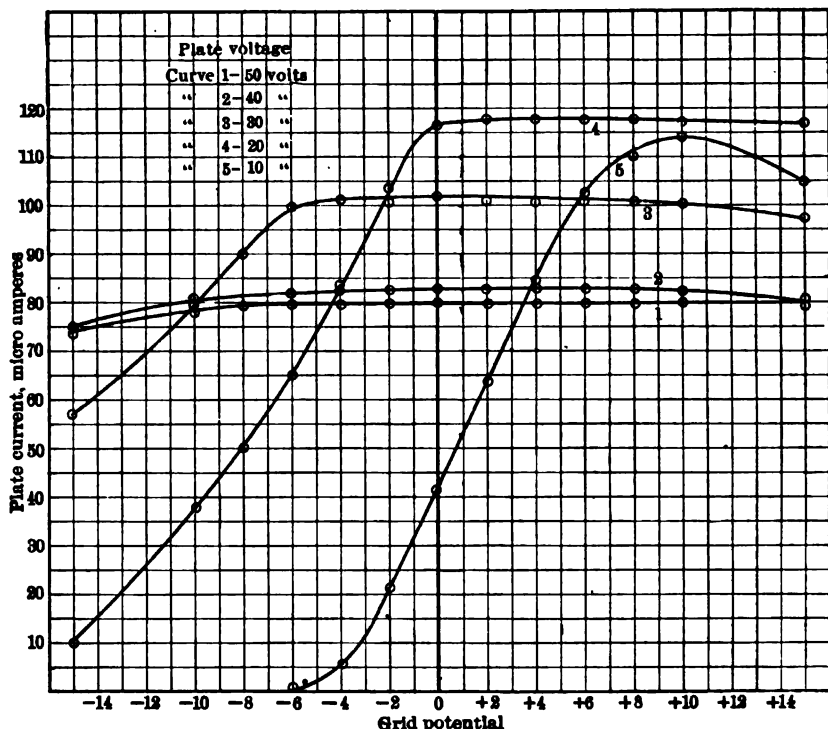

FIG. 85.—Peculiar characteristics of an old Deforest audion detector; such a tube detects in very erratic fashion, probably due to the considerable amount of gas left in the tube.

negative end of the filament to the positive end; the difference is very much exaggerated here because of the low value of the voltage of the battery in the plate circuit.

In Fig. 85 are shown the characteristics of an old Deforest detecting bulb, the filament being at the rated value for this type of bulb. It will be readily appreciated that such a tube would act peculiarly as different adjustments were made. Thus with a plate voltage between 30 and 50 the tube would not detect, with or without grid condenser. With

20 volts in the plate the tube gave very good detection with or without grid condenser; with ten volts on the plate the tube gave fair detection with grid condenser and none at all without grid condenser.

Effect of Frequency and Decrement of Signal.—The previous analyses have not taken into account the amount of electricity available for charging condenser C ; only relative reactances, etc., have been considered. But it is evident that if the condenser is to be charged the grid current must supply the electrons required, and it maybe that the current is not sufficiently large to do this, in the short time the signal is impressed.

Suppose the signal voltage has the form shown in Fig. 86; it reaches its maximum in three cycles and then rapidly decreases. If possible the grid condenser C should be charged up to a potential fixed by the *maximum* value of this signal. To make the problem simple we will suppose the amplitude of the voltage to have its maximum value during

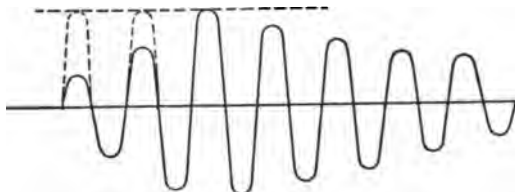

FIG. 86.—In analyzing the effect of the decrement of the signal on the detecting action we assume the first three cycles of a wave-train have the same amplitude, the maximum value of the signal voltage.

the first three cycles and examine the possibility of the condenser C having reached the value of potential fixed by Eq. (16).

If the condenser is to have its potential changed by ΔE_g , the required quantity of electricity is $(\Delta E_g \times C)$. The current available for charging the condenser is (very nearly) $\frac{E^2}{4} \frac{d^2 I_g}{dE_g^2}$ and for three cycles this makes available a quantity of electricity $q = \frac{3TE^2}{4} \frac{d^2 I_g}{dE_g^2}$. Now if $\frac{1}{R}$ is negligible compared to $\frac{dI_g}{dE_g}$ we get from Eq. (16)

$$\Delta E_g = \frac{E^2}{4} \frac{d^2 I_g}{dE_g^2} \frac{dE_g}{dI_g}$$

So, as $q = C\Delta E_g$, we may put

$$C \frac{E^2}{4} \frac{d^2 I_g}{dE_g^2} \frac{dE_g}{dI_g} = \frac{3TE^2}{4} \frac{d^2 I_g}{dE_g^2}$$

from which we conclude that the largest condenser which can be used, and still be fully charged, is fixed by the relation $C = 3T \frac{dI_g}{dE_g}$.

If $\frac{dI_g}{dE_g} = 5 \times 10^{-6}$ (which is about the value obtained from Fig. 78, when E_{gg} is -0.6 volt) and T is 2×10^{-6} (which is the period of a 600-meter wave),

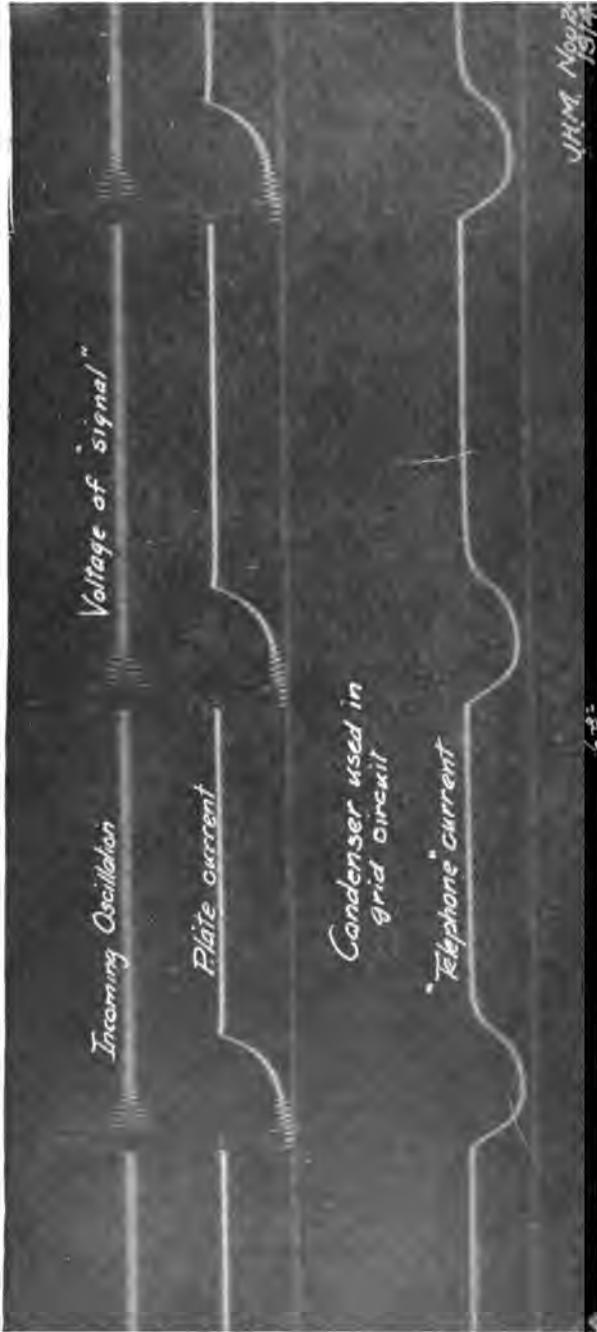

FIG. 87.—Oscillogram showing the action of the tube as detector when a condenser (with suitable grid leak) is used in series with the grid.

the maximum value of capacity should be 10×10^{-12} farads. But such a low value for C would result in a very small fraction of the signal voltage being impressed on the grid, so that a much larger condenser must be used and the value of $\frac{dI_g}{dE_g}$ must be made larger.

By using a lower value for the leak resistance, R , the normal grid potential E_{00} may be made higher, which will result in a higher value of $\frac{dI_g}{dE_g}$; in Fig. 78 when $E_{00} = 0$, $\frac{dI_g}{dE_g} = 15 \times 10^{-6}$. If the decrement of the signal is low, we may allow more than three cycles for the condenser to charge without greatly decreasing ΔE_g , because the amplitude of signal voltage will still be nearly its maximum value.

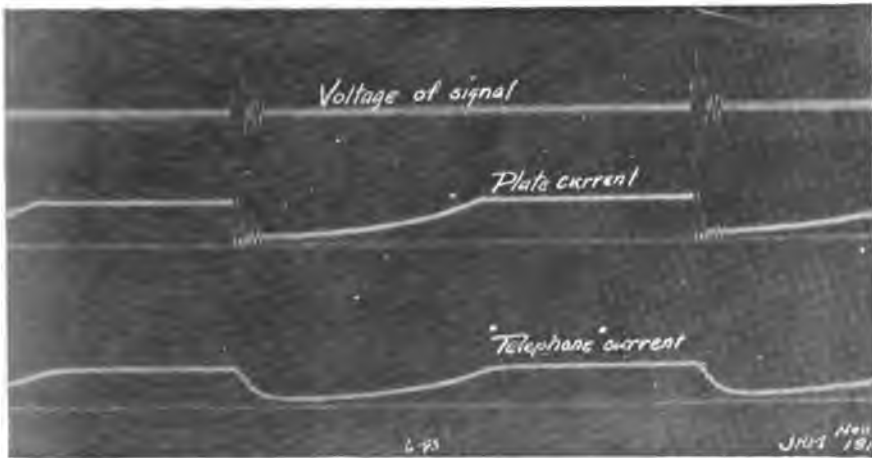

FIG. 88.—By increasing the value of the grid leak the form of the plate current curve may be changed; in this film all conditions were the same as those of Fig. 87 except the value of the grid leak resistance had been approximately trebled.

From the foregoing discussion it is evident that the predetermination of the best value for C is somewhat involved; moreover it will be found experimentally that C may be varied over a wide range without appreciably changing the efficiency of the tube as a detector, probably due to compensation among the different effects just mentioned. A large C will not charge completely, e.g., but it will permit a greater fraction of the input voltage to act on the grid than would a smaller one which would charge more completely.

The action of the tube as detector with grid condenser is well shown in Fig. 87, a film taken by the author in 1914. In the upper part of the figure is shown the input voltage; the second curve shows the plate current, having pulsations of the same frequency as the signal voltage, but having also a large average decrease due to the grid condenser becoming

charged; the "telephones" (in this case a coil of high inductance) were shunted by a large capacity so that the "high-frequency" fluctuations in plate current did not pass through them, but the low-frequency change in plate current did pass through them, giving a current of the form shown.

By increasing the value of the leak resistance about three times the time required for the grid condenser to discharge was increased and so the plate current was held at its lowered value for a longer interval of time; the currents then had the forms shown in Fig. 88.

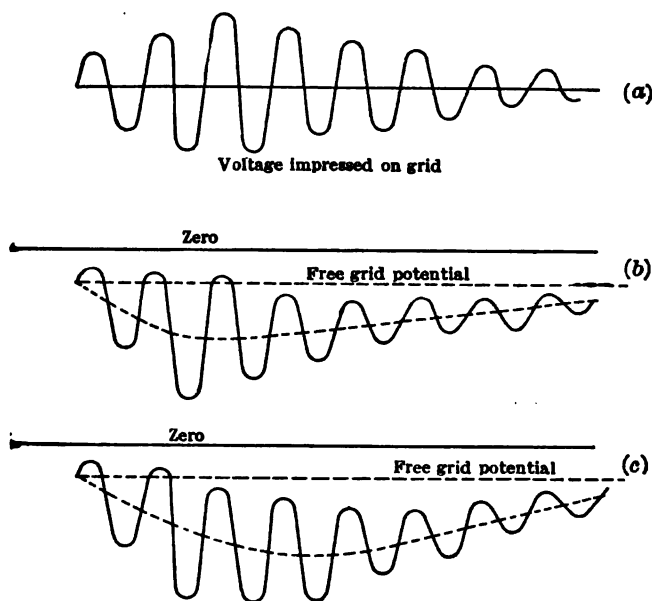

FIG. 89.—This diagram shows in (b) a correct representation of the grid potential when signal (a) is impressed and in (c) an incorrect representation. The average potential of the grid will not be further depressed unless during the previous cycle the grid is forced to a potential higher than its "free" potential.

It is to be noted that the mean potential of the grid can be no longer depressed when the fluctuations in grid potential due to the signal do not carry it to a potential more positive than its free potential. Unless its potential exceeds the free potential it will not attract any excess electrons (i.e., more than it attracts when no signal is coming in) and hence cannot depress the average potential of the grid. In this respect many writers have shown the action of the three-electrode tube incorrectly; in Fig. 89 curve (a) shows the voltage impressed on the grid due to the signal and in (b) is shown correctly the resulting grid potential, the average potential being shown by the dotted line. After the third cycle the

signal voltage is not of sufficient magnitude to carry the grid potential higher than its free value; after this time, therefore, the average grid potential must rise due to the accumulated charge escaping through the leak resistance.

In curve (c) is shown the grid potential as frequently given in texts; the average potential is shown as decreasing further even when, during the previous cycle, the grid potential did not rise as high as its "free" value; this illustration is incorrect.

The term "accumulative amplification" has been used in describing the action of a tube with grid condenser, but it is to be noticed that there is no true amplification; the grid potential is in no case depressed by an amount *in excess of the amplitude of the signal e.m.f.*, as it is when real amplification is used.

Measurement of Detecting Efficiency of a Three-electrode Tube.—

It is possible to experimentally determine the detection coefficient of a tube by such a scheme as that originated by Van der Bijl;¹ in his treatment it is shown that the strength of signal given by the telephone varies as the fourth power of the voltage impressed on the grid. This follows at once also from Eq. (12), page 450, in which it is shown that the increment of plate current varies with the square of the voltage impressed on the grid; as the amount of noise given off from the telephone varies with the square of the current through it, it is evident that the noise varies with the fourth power of the grid voltage.

Using a receiver which required 3×10^{-12} watts input to produce the "least audible signal" Van der Bijl found that the ordinary detector tube (without a condenser in series with the grid, depending only on shape of plate current curve for rectification) required a signal voltage of 0.025. Unless some very radical change is made in either telephone receiver or detecting tube, it may be assumed that, for a readable signal, it is necessary to impress on the grid of a detector a voltage (high frequency) of between .01 volt and .05 volt.

Requirements for a Good Detecting Tube.—Besides the necessary mechanical features of ruggedness, ease of duplication, long life, etc., there are certain electrical features which should be embodied in a good detecting tube. The present forms of detecting tubes use altogether too much power in heating the filament, and more voltage in the plate than should be required. The excessive power used in the filament has two disadvantages; the filament battery required is much larger than necessary and there is altogether too much emission from the filament. A power consumption in the filament of less than one watt is feasible, and the emission should not be more than about 100 microamperes, the

¹ H. J. Van der Bijl, "On the Detecting Efficiency of the Thermionic Detector," Proc. I.R.E., Dec., 1919.

plate voltage being ten or less. Such a tube would probably have an alternating-current resistance in the plate circuit of perhaps 10^5 ohms, so the telephones could not be efficiently introduced directly in the plate circuit; a step-down transformer or another low impedance tube would be required to supply the telephones.

The advantages of using a tube with comparatively low emission from the filament come from its limitation on the strength of disturbances which may occur. Atmospheric disturbances constitute the present limiting condition of radio; irregular cracks and hisses are produced in the phones, perhaps hundreds of times louder than the signal and so make the signal unreadable. If these disturbances can be limited in strength,

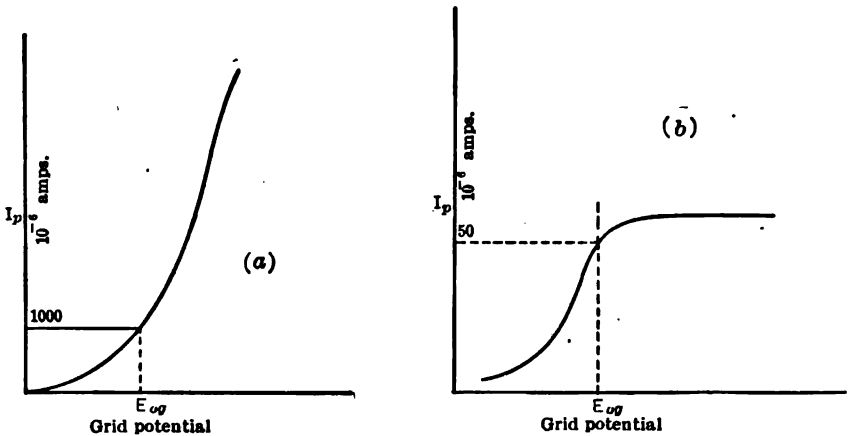

FIG. 90.—A detector tube having the characteristic shown in (b) is preferable to the one shown in (a) because of the lesser effect of static interference in one than in the other.

so that they are not more than five or ten times the signal strength, a good operator will read right through them; with the present tubes these disturbances may be thousands of times as strong as the signal. Graph (a) of Fig. 90 illustrates the present detector tube; normal plate current may be 500–1000 microamperes and the total emission may be 5000 microamperes. A strong signal (such as an atmospheric pulse) may decrease the plate current to zero or increase it to 5000 microamperes, whereas the signal is probably not changing it by more than one or two microamperes. The effect of strong disturbing noises such as static is to deafen the operator's ear for the weaker signal.

If the tube used for detector has the characteristic shown in graph b of Fig. 90, the effect of stronger pulses of e.m.f. impressed on the grid is much less; the saturation current of the tube does not permit a large increase of plate current, no matter how high a positive potential may

be impressed on the grid and the reduction of the plate current to zero by a negative potential in the grid cannot produce as great a disturbing noise as for the other tube, because the normal plate current for tube (b) is only 1/20 as much as it is for tube (a).

A tube having the characteristic shown in (b) would probably not be as efficient a detector as tube (a), but this defect would be remedied by a suitable amplification. Another advantage of tube (b) would be its comparatively small internal capacity, because its parts could be much smaller than the present detecting tube; the feature above would make the smaller tube preferable, because the capacity of the input circuit of a tube is a serious factor in the design of amplifiers, especially those used for amplifying high-frequency currents.

The Three-electrode Tube as a Source of Alternating Current. General Field of Application.—A three-electrode tube, if connected to a circuit having a natural period of oscillation, will, if certain conditions are satisfied, generate alternating-current power of the frequency fixed by the L and C of the circuit to which it is connected. The action is nearly analogous to that of a violin bow; although the force and velocity of the bow are essentially constant the peculiar friction between the bow and string enables the string to absorb more power from the bow when string and bow are moving in the same direction than is given back to the bow by the string when the motions of bow and string are in opposite direction. If the frictional force between string and bow is plotted as a function of the relative velocity of the two, the graph will have the form given in Fig. 91; curve (a) is for the bow without resin and curve (b) shows the change in this friction after resin has been put on the bow.

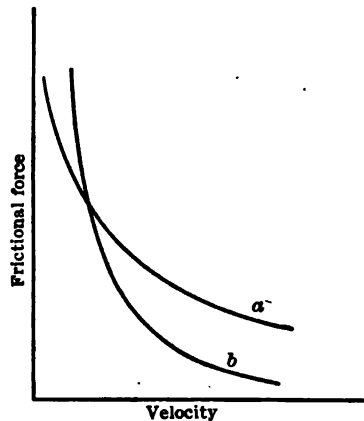

FIG. 91.—Frictional force between a violin string and bow, as a function of their relative velocities, the greater the difference in their velocities the less is the frictional force between them. Putting resin on the bow changes curve a to curve b .

The muscles of the arm actuating the bow constitute a source of continuous power; it is obviously impossible for an arm muscle to supply (directly) power to a string vibrating 1000 times a second. The arm supplies energy to the bow at an essentially constant rate, the reactions between the bow and string serve to utilize this power to maintain the string in a state of rapid vibration.

The system which drives the balance wheel of a watch is also some-

what analogous; the mainspring furnishes power by a continuous force, but the escapement system serves to feed energy into the moving balance wheel in such a way as to maintain it in a state of oscillation, the period being fixed by the mass of the wheel and stiffness of the hairspring.

It is to be noted that neither the balance wheel nor violin string will vibrate if the damping of the oscillating member is too high; if too much friction occurs in the bearings of the balance wheel the watch will stop. The same effect exists in the oscillating tube circuits to be described later.

The efficiency of the three-electrode tube as a generator of alternating current power is normally rather low; in small tubes such as used for aeroplane telephony the circuits are generally arranged to give an efficiency¹ of about 25 per cent, and in the larger tubes to get an output of 150 watts requires an input of about 300 watts. In a later section of this Chapter the efficiency of a tube is discussed and analyzed in detail. In spite of its rather low efficiency it will probably be always used when a small amount of power is desired at a frequency of 100 kilocycles or more, because there is no other simple method of generating power at these frequencies. The Poulsen arc is at present a better method of generating high-frequency power when many kilowatts of power are required and the frequency is not too high, say not over 400 kilocycles. For frequencies greater than this the vacuum tube has no competitor as a generator, and for small amounts of power the frequency of which is preferably variable, the vacuum tube is probably better than any other device, no matter what this frequency may be.

There are two general fields in which the oscillating vacuum tube is used in radio, as a source of high-frequency power for a continuous-wave transmitting station, and as a necessary part of any station receiving continuous-wave signals, by means of the heterodyne or "beat" method.

It has been used as a source of power for transmitting up to several kilowatts of high-frequency output, but its application in such installations at present is of doubtful utility; unless the frequency desired is above the possible limits of a high-frequency alternator, it seems that a machine is preferable because of the high expenses for tubes and their short life compared to that of a machine. It seems quite likely, however, that new developments in high-power vacuum tubes will soon make them superior to any other type of high-frequency apparatus.

When used as part of a continuous-wave receiving set the oscillating tube is required to generate but a very small fraction of a watt and the smallest type of detecting tube will suffice.

For general laboratory use the small oscillating vacuum tube should

¹ In speaking of the efficiency of an electron tube the "input" does not ordinarily include the power necessary for heating the filament; it is the power supplied in the plate circuit only.

prove of great service, as a source of a few watts of alternating-current power for bridge measurements of frequency adjustable to any degree desired; as a source of complex alternating-current forms, from which exact octaves are obtainable; in combination with a suitable sound generator, such as piezo electric crystal or untuned telephone receiver, it is invaluable in a laboratory for measurements on sound.

Elementary Analysis of the Operation of a Three-electrode Tube or Generator of Alternating-current Power.—The three-electrode tube may be used as a self-exciting device or the power required to excite its grid circuit may come from some other source. This scheme is often used when it is desired to get maximum possible power from several tubes, operating in parallel. Their input circuits (grid-filament) are all connected in parallel and excited from some other, self-exciting, vacuum-tube circuit, the power capacity of which may be small compared to that of the tubes excited.

The operation of the separately excited tube is extremely simple; if an alternating voltage is applied on the input circuit, the plate current,

which is fixed by Eq. (5), must rise and fall as this grid potential alternately increases and decreases. The simplest circuit to be considered for using the alternating-current power generated in the plate circuit is that shown in Fig. 92; a choke coil L is put in series with the machine M , furnishing the plate circuit voltage, the value of L being large enough so that its reactance is large compared to the alternating current resistance R_p of the plate-filament circuit. Shunting this choke coil is the output circuit or load circuit of the tube; it consists of a condenser C , having a reactance, the magnitude of which is small compared to R_p , in series with a resistance R of about the same value as R_p . A condenser C_1 shunts the machine M to make the reactance of this part of the circuit negligible compared to R .

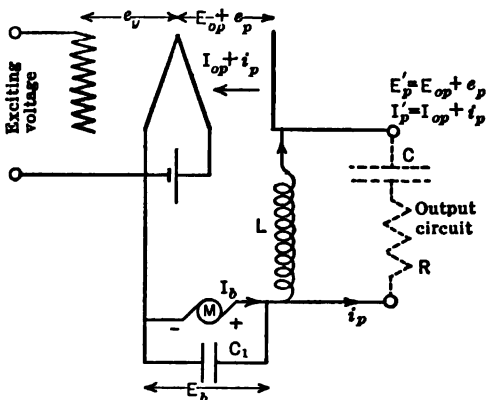

FIG. 92.—Circuit diagram of a tube to be used for generating alternating-current power; the output circuit indicated in dotted lines is shunted around the choke coil L .

With the conditions named (large L , C , and C_1), the external impedance of the plate circuit will consist of R only. As the voltage of the grid goes alternately positive and negative the plate current will fluctuate

about its normal value, I_{op} , and the plate voltage will also fluctuate about its normal value, E_{op} . The actual plate current may be considered as made up of the constant value I_{op} which flows through L , and does not appreciably vary as E_g is varied, and an alternating component i_p , which flows in the plate circuit by the path C, R, C_1 . The plate voltage similarly will be considered as made up of a constant term E_{op} on which is superimposed the alternating voltage E_p ; at any instant the actual plate voltage will be equal to $E_b - i_p R$, where i_p is the instantaneous

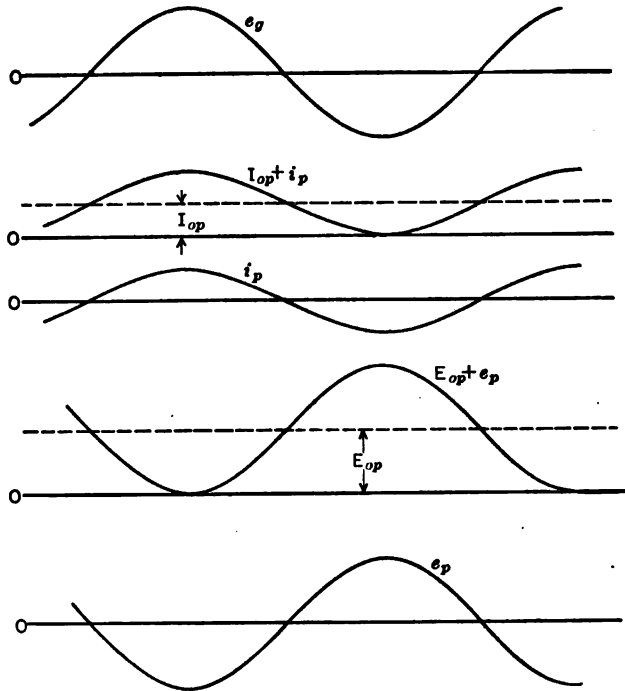

FIG. 93.—Theoretical curves of voltages and currents in a tube; actually the plate voltage does not go through such wide variations.

value of I_p . As the magnitude of E_g is increased the maximum value of I_p increases until it is practically equal to I_{op} . Under this condition, the actual current through the plate will fluctuate between $2I_{op}$ and zero and the value of plate voltage will fluctuate between $2E_b$ and zero if R is chosen of proper value. (Actually this amount of current and voltage fluctuation is not reached; the values named are limiting values.) The characteristic curves are shown in Fig. 93.

If the excitation is still further increased and the circuit L, C, R , is properly adjusted, the forms of E_p and I_p may be made to differ very

materially from the sinusoidal forms here shown. It is, however, difficult to write the theory of the various circuits for any but sinusoidal functions, and we shall assume that I_p and E_p are such, unless specific mention is made to the contrary. We shall call the oscillations normal when I_p is sinusoidal or approximately so, that is for $(I_p)_{\max} =$ or $< I_{op}$.

Output, Efficiency and Internal Losses, for Normal Oscillation.—The effect of the load resistance R on the output of a tube could be predicted by noticing that the alternating current I_p really flows through R and the tube resistance, R_p , in series; as R is decreased I_p increases, just as the load current from any alternator increases when the resistance of its load circuit is decreased. The voltage E_p impressed on the grid circuit generates in the plate circuit an alternating current through R_p and R in series.

If sufficient excitation is supplied to the grid circuit to force the actual plate current to vary between zero and $2I_{op}$, the maximum value of the alternating current, I_m , though R and R_p (in series) is I_{op} . The alternating current power delivered to the external circuit is

$$P_m = \frac{I_m^2}{2} R = \frac{1}{2} \left(\frac{\mu_0 E_{m\theta}}{R_p + R} \right)^2 R, \dots \dots \dots (19)$$

$E_{m\theta}$ being the maximum value of the voltage impressed on the grid.

If now $R = R_p$, we have,

$$P_m = \frac{(\mu_0 E_{m\theta})^2}{8R} \dots \dots \dots (20)$$

The generated voltage, $\mu_0 E_p$, is used up in overcoming the two drops $I_p R_p$ and $I_p R$, so we have,

$$I_{mp} R_p + I_{mp} R = \mu_0 E_{m\theta}$$

and if

$$R_p = R,$$

$$2I_{mp} R = \mu_0 E_{m\theta}$$

But the maximum possible value of the drop across R is E_{op} ; we therefore have $\mu_0 E_{m\theta} = 2E_{op}$. Hence from Eq. (20), we get,

$$P_m = \frac{4E_{op}^2}{8R} = \frac{E_{op}^2}{2R} = \frac{E_{op}}{2R} (I_{mp} R) = \frac{E_{op}}{2R} I_{op} R = \frac{E_{op} I_{op}}{2} \dots \dots (21)$$

But the input to the plate circuit is $E_{op} I_{op}$, the value of which we assume, is independent of the magnitude of the external resistance R . It therefore follows that *a separately excited tube having sinusoidal variations in the plate current has a maximum efficiency of 50 per cent, and that this occurs for the same condition as gives maximum output, i.e., $R = R_p$.*

This theoretical limit of efficiency is never reached, because the plate current cannot be made to execute harmonic changes and still be forced

to zero value. The reason for this is the variation in μ_0 when the plate voltage becomes very small and the grid voltage large (in positive value; neither does μ_0 hold constant when the plate voltage is very high and with a high negative potential on the grid.

Of course the efficiency factor of 50 per cent neglects the losses in the grid, or exciting circuit, which really should be charged up to the tube, and also the power required to heat the filament. These two factors very materially reduce the possible efficiency of the tube as a generator.

As mentioned above, this limiting figure of 50 per cent for efficiency holds only for sinusoidal plate current; it is possible to so operate the tube that the plate current is much distorted and at the same time the efficiency is increased to perhaps 85 per cent or more. This case will be taken up later in this chapter.

A large-power tube was connected as indicated in Fig. 92 and the effect of variation in R was noted. The grid excitation E_g was kept sufficiently low so that the tube was not being worked near its limiting output for any value of R used.

The results are given in Fig. 94, and serve well to show how the power output varies with the resistance of the load circuit; the magnitude of the alternating current generated by the tube is also shown on the curve sheet. It is apparent that this tube should be used with a load circuit resistance close to 1000 ohms if maximum power is to be obtained.

The effect of continued operation on the characteristics of the tube is shown by the dotted curve; it shows the output (for exactly the same conditions as were used for the solid curve) after the tube had been operating for twenty minutes. The temperature of the filament depends not only on the filament current, but also on the temperature of the plates; the hotter the plates the higher will be the filament temperature for a given filament current, and of course the more will be the emission of electrons.

For the lower values of R (less than 500 ohms) it will be noticed that the alternating current exceeds 0.707 of the current supplied by the machine in the plate circuit; with sinusoidal current in the load circuit this condition could not occur; it must therefore be that the current in the load circuit was distorted in form when the lower values of load circuit resistance were used.

The curves do not show faithfully the characteristics of the tube as a generator for the higher values of the load circuit resistance because the choke coil used in the plate current circuit had an impedance of only 8000 ohms, so that the supply current was far from constant for the higher values of R . This supply circuit acted as a partial short circuit for the load circuit, more so as R increased in value.

Heating of the Plates of a Tube.—The safe limit of operation of a power tube is fixed by the allowable heating of the plates; with no oscillations taking place (no excitation of input circuit) the total power delivered by the plate circuit battery or generator must be used in heating the plate, the resistance of the choke coil L (Fig. 92) being negligible. When the tube is oscillating to the extent indicated by the curves of Fig. 93, one-half the input $E_b I_{op}$ is delivered to the output circuit R , hence only one-half of $E_b I_{op}$ is used in heating the plates, whereas if the excitation is removed the heating of the plates is given by $E_b I_{op}$. If, therefore, a tube is

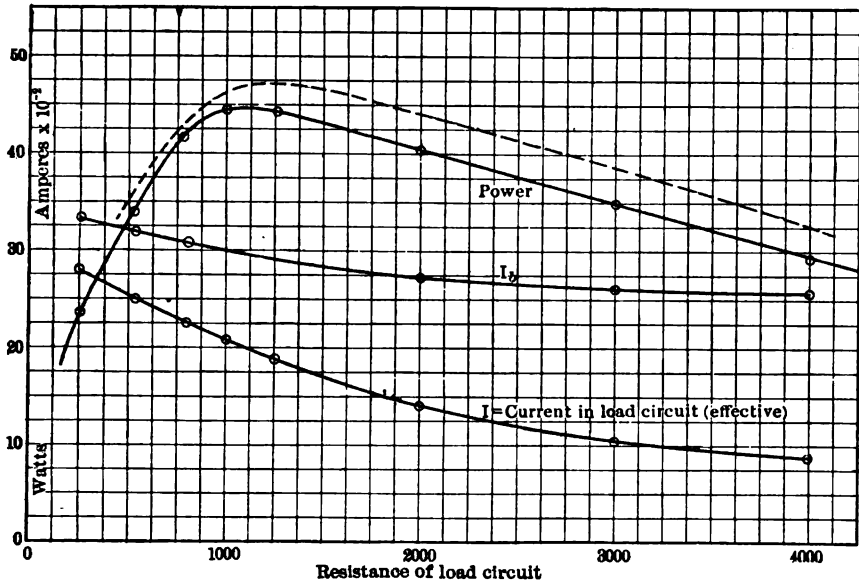

FIG. 94.—Variation in output of a power tube as the resistance in the load circuit is varied grid excitation remaining constant; circuit connected as shown in Fig. 92.

rated as 250 watts on the plate, the product $E_b I_{op}$ must not exceed 250 when the tube is not oscillating, but if the tube is generating alternating-current power, and conditions are adjusted for maximum output (sinusoidal variations of I_p assumed) the input, $E_b I_{op}$, may be safely increased to practically double the rating, or 500 watts.

Another way of obtaining the amount of power used on the plate is to write the expression for $E'_p I'_p$ from Fig. 92 (where E'_p and I'_p are the voltage between plate and filament, and current through tube, respectively) and find its average value. It is

Power expended on plates = $\frac{1}{T} \int_0^T E'_p I'_p dt$. Now as E_p and I_p are 180° out of phase (high-plate voltage occurring at the same instant as low-plate

current occurs), we have for the power used on the plates (where E'_p and I'_p are fluctuating as much as shown in Fig. 93),

$$\begin{aligned} \text{Power} &= \frac{1}{T} \int_0^T (E_b + E_b \sin pt)(I_{cp} + I_{op} \sin (pt + \pi)) dt \\ &= E_b I_{op} - \frac{1}{T} \int_0^T (E_b I_{op} \sin^2 pt) dt \\ &= E_b I_{op} - \frac{E_b I_{cp}}{T} \int_0^T \left(\frac{1 - \cos 2pt}{2} \right) dt = E_b I_{cp} - \frac{1}{2} E_b I_{op} = \frac{1}{2} E_b I_{op}. \end{aligned} \quad (21)$$

If the circuit is not adjusted to give maximum output the proportion of the input power which is used in heating the plates is increased, so the input power must be reduced if safe rating of the plates is not to be exceeded. The input can in general be cut down by decreasing either the filament current or plate voltage, or by introducing a suitable battery or other device into the grid circuit so as to lower its normal potential.

Phase Relations of Voltages and Current in a Vacuum-tube Generator.—We have previously mentioned the fact that there is no appreciable lag or lead of the electron current in a vacuum tube with regard to the electric field causing the current to flow; this is true for the highest frequencies ever generated by vacuum-tube circuits. As the electric field is produced by both the plate and grid acting together we have the fundamental fact expressed by Eq. (5), which holds for the instantaneous value of the current as well as for the steady state. If then e_p designates the instantaneous value of the alternating component of the plate voltage, e_g , the same for the grid voltage and i_p is the instantaneous value of the alternating component of the plate current (grid current to be neglected in this discussion) we have,

$$i_p = A(e_p + \mu_0 e_g). \quad (22)$$

This equation holds true only if the value of $(e_p + \mu_0 e_g)$ is sufficiently low to produce sinusoidal values of i_p ; under this condition it is evident that the constant, A , is the reciprocal of the alternating-current plate circuit resistance, which we have previously called R_p . The value of this R_p will depend upon the constant values of plate and grid potentials, E_{op} and E_{og} , increasing with a decrease of either of them.

If the external impedance in the plate circuit is R , as in Fig. 92, $e_p = -i_p R$, the minus sign arising from the condition that plate current greater than normal ($I'_p > I_{op}$, or i_p positive) causes a plate voltage less than normal ($E'_p < E_{op}$ or e_p negative). Using this relation in Eq. 22 and substituting $\frac{1}{R_p}$ for A , we get,

$$i_p R_p = -i_p R + \mu_0 e_g. \quad (23)$$

from which we get,

$$e_g = i_p \frac{R_p + R}{\mu_0},$$

or in effective values

$$E_g = I_p \frac{R_p + R}{\mu_0} \dots \dots \dots (24)$$

In this case the grid voltage and plate current are exactly in phase with one another and the required value of grid excitation, for a certain magnitude of I_p , is at once calculable from Eq. (24). The plate voltage e_p is equal to $-i_p R$ and so is exactly 180° out of phase with the grid, or exciting voltage. The vector diagram is shown in Fig. 95; it will be noticed that $\mu_0 E_g$ must be greater than E_p by an amount equal to $I_p R_p$.

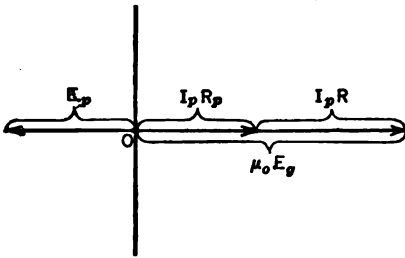

FIG. 95.

FIG. 95.—Phase relations of voltages in the tube circuit of Fig. 92, the load circuit being resistive only.

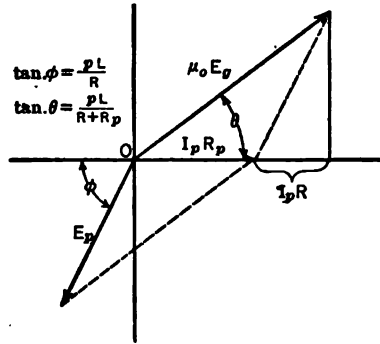

FIG. 96.

FIG. 96.—Phase relations of voltages in the tube circuit of Fig. 92, the load circuit having resistance and inductive reactance.

In case an inductive reactance is used in the plate circuit, we have the relation $e_p = -i_p(R + jpL)$ and this relation used in Eq. (22) gives

$$e_g = i_p \frac{(R_p + R) + jpL}{\mu_0},$$

or in effective values

$$E_g = I_p \frac{\sqrt{(R_p + R)^2 + (pL)^2}}{\mu_0} \dots \dots \dots (25)$$

The vector construction for this case is shown in Fig. 96; the various phase relations will evidently depend upon the ratio $\frac{pL}{R}$ and upon the relation between R_p and R . In case the reactance-resistance ratio of the coil used in the plate circuit is high (an efficient coil) the voltage E_p will lag behind the plate current I_p by practically 90° , but the grid voltage cannot lead the plate current by such a large angle; even if the resistance

of the coil in the plate circuit is negligible the angle of lead of E_g with respect to I_p is fixed by the angle whose tangent is $\frac{pL}{R_p}$.

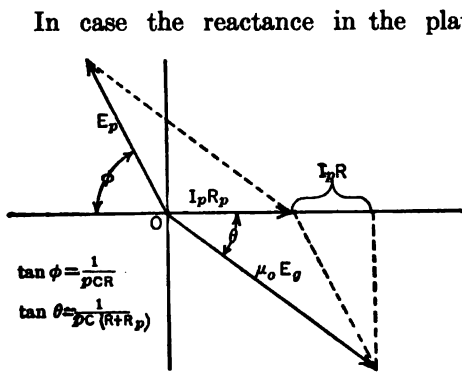

FIG. 97.—Phase relations of voltages in the tube circuit of Fig. 92, the load circuit having resistance and capacitive reactance.

In case the reactance in the plate circuit is large and negative (which would be the case in Fig. 92 if C is decreased so that its reactance is appreciable) the phase relations are as shown in Fig. 97; the plate current now leads the exciting voltage E_p , and lags behind the plate voltage E_p , by some angle between 90° and 180° .

The grid voltage required to produce a certain current, I_p , through the condenser C , shunting the choke coil in the plate circuit, is given by the equation,

$$E_g = I_p \frac{\sqrt{R_p^2 + \left(\frac{1}{pC}\right)^2}}{\mu_0} \dots \dots \dots (26)$$

If there is power used in the circuit through which I_p flows, it must be taken care of by a suitable resistance in series with C ; Eq. (26) must then have its resistance term increased by the value of the equivalent series resistance.

In Figs. 98, 99, and 100 are shown oscillographic proofs of the foregoing statements; the voltages and currents are not pure sine waves and so do not obey exactly the relations just obtained on the assumption that all currents and voltages were sine waves. The distortion in I_p is explained by the fact that R_p varies through the cycle; its average value for the conditions existing when the films of Figs. 98, 99, and 100 were obtained was about 2500 ohms.

Effect of Phase Relations on the Possible Power Output of a Tube Generator.—From the foregoing analysis it is evident that a tube generator can act on its output circuit with a voltage E_p , the maximum value of which is somewhat less than the normal plate voltage E_{op} ; also that it can supply to the output circuit an alternating current I_p , the maximum value of which is somewhat less than the normal plate current I_{op} . If I and E represent the effective values of voltage and current which the tube furnishes to its output circuit, it is evident that the maximum power output will occur when the load circuit is such as to bring I and E in phase

and that the output is then equal to EI , which is also equal (in the limiting case of maximum output) to $\frac{1}{2}E_{op}I_{op}$.

Now if the load circuit is such that E and I are in phase, it is evident that its impedance must be resistance only, furthermore the value of this resistance must be equal to E/I , which is also the alternating-current resistance of the plate circuit of the tube. The truth of this statement was shown in Fig. 94.

For such a circuit as that given in Fig. 92, the magnitude of current I_p must be directly proportional to E_g , as indicated by Eq. (25). Due

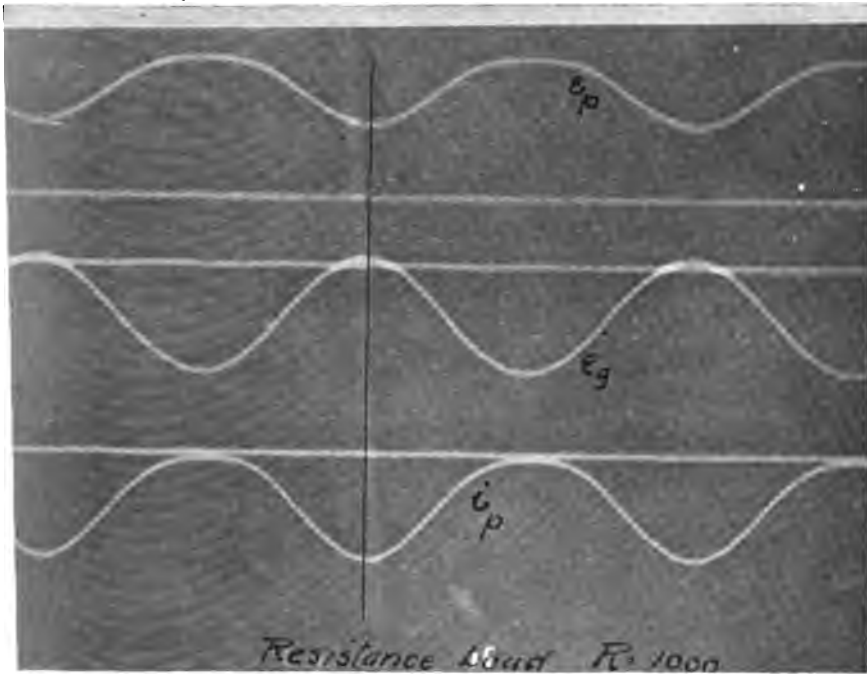

FIG. 98.—Oscillogram of grid voltage, plate voltage, and plate current, corresponding to conditions of Fig. 95.

to the non-sinusoidal currents and voltages, however, this relation does not hold good, except for low values of grid excitation; the alternating current does not change as rapidly as indicated by Eq. (25). In Fig. 101 are shown curves of load circuit power and current as functions of E_g , the resistance of the load circuit having been adjusted equal to the tube resistance at low excitation. The output increases with the square of the grid voltage for very low grid voltages only and for the higher values of excitation the output is increasing at a rate lower even than the first power of the grid voltage.

There is shown also in Fig. 101 the value of the current taken by the grid; as long as the grid was not forced positive with respect to the filament the reading of the continuous current ammeter in the grid circuit was zero, but when the value of alternating voltage impressed on the grid exceeded $\frac{1}{\sqrt{2}}$ of the normal negative grid potential, E_{og} , the grid was positive for a small portion of the cycle and so took current. The variation of the reading of the grid ammeter is shown by the curve marked I_g ; it was zero until

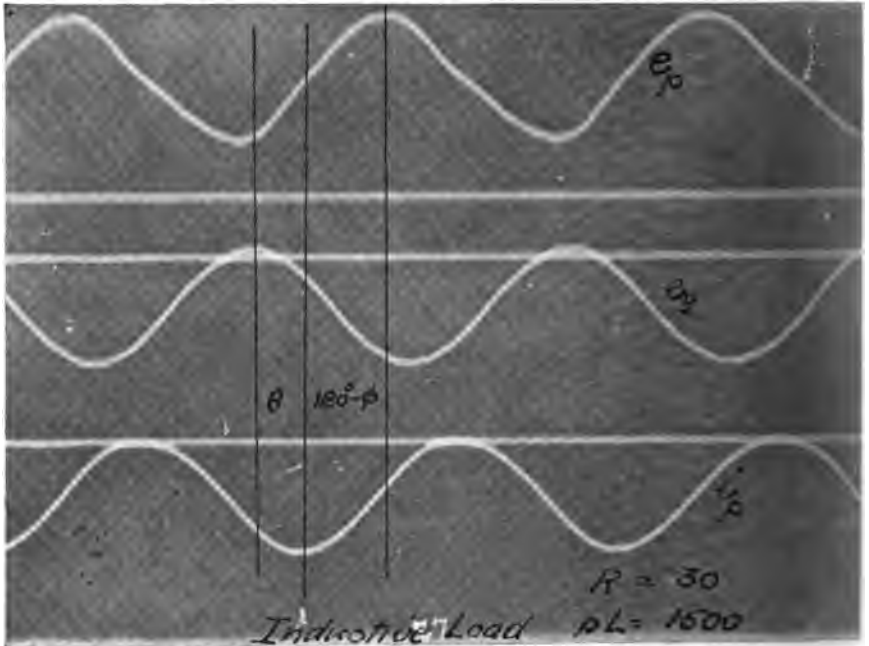

FIG. 99.—Oscillogram of plate voltage, grid voltage, and plate current, corresponding to conditions of Fig. 96.

E_g reached a value of 80 volts (effective) which is approximately equal to 70 per cent of the voltage, E_{og} , and for higher voltages rose to a value of several milliamperes. This is the average value of the grid current, because a continuous current ammeter reads average values; the grid current flows for only a small fraction of the cycle, so that the actual maximum value of I_g is probably ten times as large as the value given on the curve sheet. An accurate analysis of these voltages and currents will be given in a later section of this chapter.

General Analysis of the Conditions Necessary for Self-excitation.—From the analysis given so far it is evident that if a vacuum tube is going

to operate efficiently as a generator of alternating current power, it is necessary to have in the plate circuit a load having a resistance equal to that of the tube; it is also necessary to have such reactions occurring in the circuit to which the tube is connected that when the plate current undergoes sinusoidal variations the plate potential and grid potential both undergo sinusoidal variations of potential in opposite phases, and that the relative magnitudes of these two potential variations be properly adjusted for the tube being used. The fundamental requirements of the

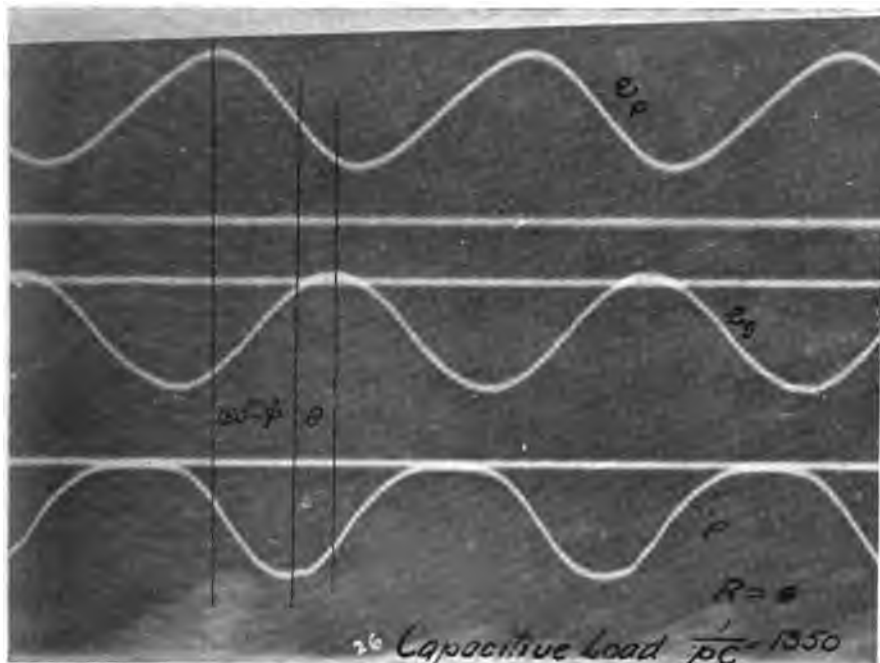

FIG. 100.—Oscillogram of plate voltage, grid voltage, and plate current corresponding to conditions of Fig. 97.

problem can be readily specified. In Fig. 102 are shown the filament, plate, and grid terminals 1, 2, and 3; the filament battery and plate circuit battery (or machine) are omitted, as they do not enter directly into the determination of the conditions for self-excitation of the tube.

If the normal plate voltage and plate current are E_{op} and I_{op} respectively, we know that the tube can, when operating properly, generate an amount of power somewhat less than $\frac{1}{2} E_{op} I_{op}$; let us call this available power P . If this power is supplied to a circuit of L , C and R , in series, it will produce a current fixed in magnitude by the relation $P = I^2 R$. This current, I , will produce an alternating voltage between the terminals of

L , the effective value of which is equal to $I\omega L$, where ω is nearly equal to $\frac{1}{\sqrt{LC}}$.

When generating the amount of power P the potential of point 2 must be fluctuating in voltage (with respect to the filament) by an amount approximately equal to E_{op} . The potential of point 3 must be fluctuating, with respect to the filament, by an amount E_{ms} , such that $\mu_0 E_{ms}$ is about equal to $2E_{op}$, as shown in Fig. 95.

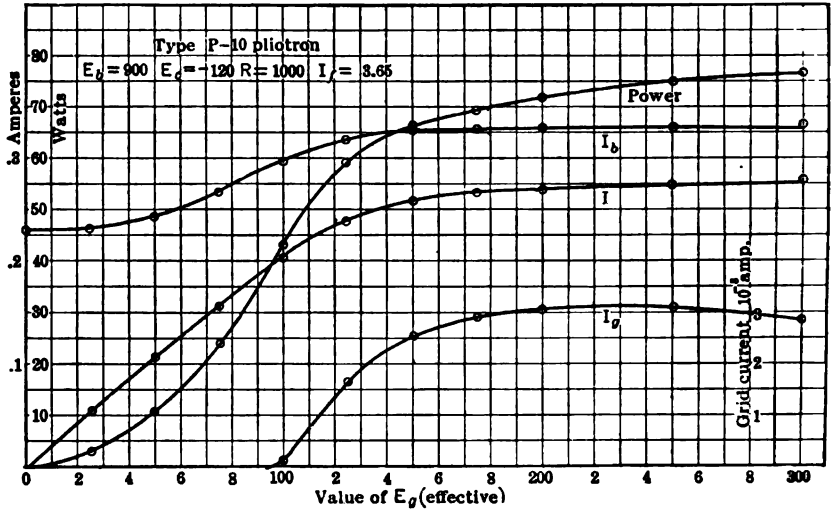

FIG. 101.—Variation of output current and power as the exciting voltage on the grid is increased; the circuit was arranged as shown in Fig. 92. Variations of I_b and the average grid current are also shown.

It is then evident (referring to Fig. 102), that if we connect the filament to point 4 of the coil, we must connect points 2 and 3 to points in the coil, (on opposite sides of point 4, such as 5 and 6) such that the maximum value of voltage between 4-5 is equal to E_{op} and the maximum voltage between points 4-6 is equal to $\frac{2}{\mu_0} E_{op}$.

If the resistance drop in the coil is negligible compared to the reactance drop, we must have (neglecting the effect of mutual induction between L_{4-5} and L_{4-6}),

$$\sqrt{2}I\omega L_{4-5} = E_{op} \dots \dots \dots (27)$$

$$\sqrt{2}I\omega L_{4-6} = \frac{2}{\mu_0} E_{op} \dots \dots \dots (28)$$

The current flowing through the coil L between points 4 and 5 is really the combination of the actual pulsating plate current and the current I which is flowing in the oscillatory circuit. If I is large compared to the alternating component of the plate current I_p , the error made in assuming the drop between points 4 and 5 as due to I only is small. In a typical radio circuit I was 0.50 ampere and the effective value of I_p (alternating component of plate current) was only 0.03 ampere. It will be noticed, however, that if the resistance of the oscillating circuit is large I decreases in value so that the assumption is no longer justified.

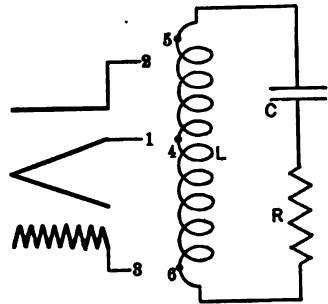

FIG. 102.—Diagram to show the conditions required for self excitation; an oscillatory circuit, of suitably low resistance, must be connected to plate, filament, and grid about as indicated. (Filament and plate circuit batteries not shown.)

If we now use the approximate relation,

$$P = \frac{E_{op} I_p}{2} \text{ and } P = I^2 R,$$

we get from (27)

$$\omega L_{4-5} \sqrt{\frac{E_{op} I_{op}}{R}} = E_{op},$$

or

$$\omega L_{4-5} = \sqrt{\frac{R E_{op}}{I_{op}}} = \sqrt{2 R R_p},$$

on the assumption that $R_{op} = 2R_p$.¹

If we now make the assumption that $\omega = \frac{1}{\sqrt{LC}}$ (which would be nearly true if the input and output circuits of the tube had negligible capacities) we find,

$$L_{4-5} = \sqrt{2 R R_p L C}. \dots \dots \dots (29)$$

And for the proper grid excitation, we should have,

$$L_{4-8} = \frac{2}{\mu_0} \sqrt{2 R R_p L C}. \dots \dots \dots (30)$$

As an illustration of how these approximate relations are applied to an actual circuit, we suppose a set designed to generate a frequency of

¹ In case R_p is greater than this L_{4-5} must be correspondingly increased; thus if $R_p = R_{op}$ then we must have

$$\omega L_{4-5} = \sqrt{R R_p}.$$

As previously mentioned R_p varies with the amount of excitation on the grid; a curve showing the variation in R_p is given in Fig. 115, p. 499.

600,000 cycles per second (500-meter wave), the capacity C being .0004 μf . The total resistance of the oscillating circuit is 10 ohms, the μ_0 of the tube to be used is 4 and R_p is 3000 ohms. Using the relation $\lambda = 1885 \sqrt{LC}$, we find

$$LC = .0705,$$

and therefore

$$L = 176 \mu\text{h}.$$

Then we find, $L_{4-5} = 65 \mu\text{h}$ and for L_{4-6} , we find $32 \mu\text{h}$. If the tube can supply 4 watts of power, the current in this oscillating circuit would be

$$\sqrt{\frac{4}{10}} = 0.632 \text{ ampere.}$$

If $R_p = 3000$, we have $\frac{E_{op}}{I_{op}} = 6000$, and also we have $E_{op} I_{op} = 8$. From these two equations, we find that $E_{op} = 220$ and $I_{op} = .037$. From the above values, we have

$$\omega L_{4-5} I = (2\pi 6 \times 10^5) \times (65 \times 10^{-6}) \times .632 = 153,$$

this being the effective value of the voltage impressed on the plate. But this is equal to $E_{op} \div \sqrt{2}$, as we have already assumed necessary for generating a power equal to $\frac{E_{op} I_{op}}{2}$.

This elementary analysis serves for an approximate solution of the circuit; the filament would be connected to point 4, somewhat lower than the middle of the coil and points 5 and 6 should be adjustable by multi-point switches. Normally there should be $65 \mu\text{h}$ between points 4 and 5 for the plate connection, and $32 \mu\text{h}$ between points 4 and 6 for the grid connection.

The foregoing calculations have been made on the assumption that the alternating-current output of the tube was 50 per cent of the input. Actually on a small tube like this 25 per cent efficiency would be more likely than 50 per cent; this would decrease the value of I and so require an increase in the required values of L_{4-6} and L_{4-5} .

As the alternating component of the plate current I_p is practically 90° out of phase with the power circuit current I , the required phase difference of 180° between E_p and E_g will not be obtained if I_p is appreciable compared to I . This shift in phase of E_p as the ratio $\frac{I_p}{I}$ increases, very materially reduces the possible output of the tube.

If it should happen that R and R_p are so high that the L_{4-5} required is more than about two-thirds of the whole coil L , the conditions required by Eqs. (27) and (28) could not be satisfied by this circuit, so it would not oscillate.

The case has many features in common with a shunt-wound, self-excited generator. In such a machine maximum output is reached when the external resistance is equal to the internal resistance of the machine (if the generated e.m.f. is kept constant); also if there is too much resistance in the shunt field circuit of the machine, it will not excite itself, or "build up," as it is called. This corresponds somewhat to a tube circuit having too high a resistance in the oscillating circuit.

The Oscillating Tube as a Detector of Undamped Waves.—From the explanation of the action of the three-electrode tube as a detector of high-frequency currents, given on page 440 et seq., it is evident that the amplitude of the high-frequency current must vary with audible frequency if an audible response is to be given by the telephone. In continuous-wave telegraphy the signal received by the antenna does not have variations in amplitude; a dot, e. g., might consist of 5000 cycles of a 50,000-cycle current, the amplitude of the current being constant for the duration of the 5000 cycles.

If the input circuit of the detecting tube is continually excited by a locally generated frequency of 49,000 cycles, when the signal comes in the input circuit is excited by both 49,000 cycles and 50,000 cycles, the result being a high-frequency excitation the amplitude of which varies 1000 times a second. This high-frequency, variable amplitude, input voltage will give a 1000-cycle note in the telephones, connected in series with the plate circuit of the tube. In case the locally generated, high-frequency current is produced by the detecting tube itself, it is called *autodyne reception*, in case some device other than the detecting tube is used for impressing the local high-frequency current on the grid the scheme is called *heterodyne reception*.

The excitation of the input circuit when no signal is arriving is due to the voltage $E'_{m_g} \sin \omega t$, and when the signal, $E_{m_g} \sin pt$, is being received the actual excitation of the grid circuit is $(E'_{m_g} \sin \omega t + E_{m_g} \sin pt)$ as indicated in Fig. 103.

Detection with no Grid Condenser.—We have previously shown that if the grid is actuated by a voltage $E'_{m_g} \sin \omega t$ and if the plate current varies as the square of the grid potential, the increase in plate current is given by $\frac{1}{2}$ (average value of e_g)² $\times \frac{d^2 I_p}{dE_g^2}$. Hence when the excitation is such as given by curve Fig. 103, the increase in plate current is,

$$\Delta I_p = \text{average value of } \frac{(E'_{m_g} \sin \omega t + E_{m_g} \sin pt)^2}{2} \frac{d^2 I_p}{dE_g^2}$$

$$= \left\{ \frac{E_{m_g}^2}{4} + \frac{E'_{m_g}{}^2}{4} + \text{average value of } E_{m_g} E'_{m_g} \sin \omega t \sin pt \right\} \frac{d^2 I_p}{dE_g^2}$$

The first two terms give the increase in the plate current which is constant, as long as the excitation is applied; their effect would produce an increase in the value of the plate current as read by a continuous-current ammeter in the plate circuit, but they would not produce a readable signal in the phones, giving only a slight click in the phones when the excitation is put on the grid and another when it is taken off.

Whatever audible signal is obtained must come from the third term; this may be written in the expanded form

$$\frac{1}{2} E_{m_g} E'_{m_g} (\cos (\omega-p)t - \cos (\omega+p)t) \frac{d^2 I_p}{d E_g^2}$$

The average value of both these cosine terms is zero, but $\cos (\omega-p)t$ may fluctuate so slowly as to produce an audible signal in the phones, and

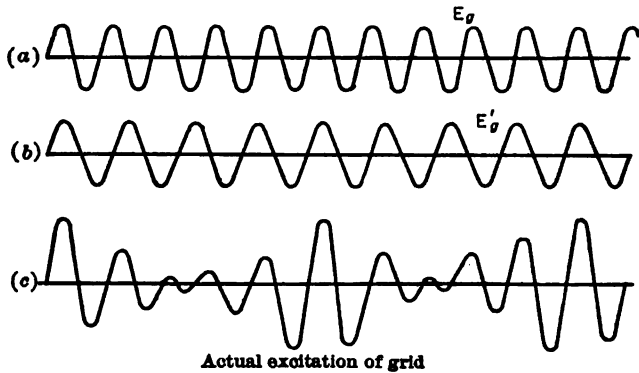

FIG. 103.—Conventional diagram of a continuous wave signal voltage E_g , a locally generated voltage of slightly different frequency, and the sum of the two, which is the voltage acting on the grid.

it is this term which is useful in continuous-wave detection. The strength of signal is then measured by this term.

$$\Delta I_p(\text{of audible frequency}) = \frac{E_{m_g} E'_{m_g}}{2} \cos (\omega-p)t \frac{d^2 I_p}{d E_g^2} \dots (31)$$

The frequency of this fluctuation in the plate current, which is the note heard in the phones, is adjustable by the operator, as he can make the value of ω anything he may desire. The ear and phone are both most sensitive at a frequency of about 800 cycles per second, so ω is generally adjusted to give $\frac{\omega-p}{2\pi} = 800$, or $\frac{p-\omega}{2\pi} = 800$.

It is to be noticed that whereas the response of the tube detector is proportional to the square of the signal strength for damped wave signals Eq. (12), it is proportional to the first power of this signal strength when used for continuous-wave receiver. This fact makes the tube a better

detector of signals for undamped, than for damped, waves, its sensitiveness not decreasing with the strength of signal so rapidly for one as it does for the other. Eq. (31) shows also that the response to a given signal varies with E' , the amplitude of the local oscillations, so long as the variation of E' , does not change the value of $\frac{d^2 I_p}{dE_o^2}$.

This increase in response with the strength of the local oscillations is similar in character to the increase in response of a telephone receiver due to the use of the permanent magnet. It is not a characteristic peculiar to a vacuum tube, but holds for any detecting device in which the response varies with square of the impressed force (when a single frequency is impressed). A crystal rectifier has a nearly parabolic relation between the current through it and the impressed voltage (see Fig. 60, p. 347) and the curve of response as

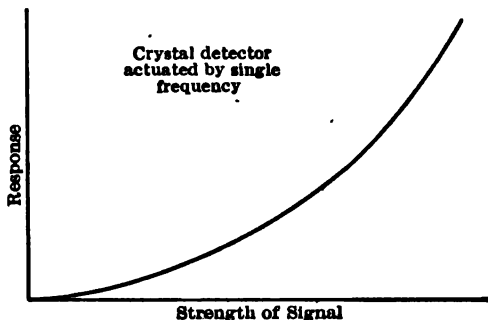

FIG. 104.—Rectifying action of a crystal actuated by a single frequency.

a function of the signal strength is as shown in Fig. 104, when it is used to detect spark signals. If, however, the crystal is used to detect continuous-wave signals by use of an auxiliary source of continuous wave excitation (Fig. 105), its response follows the same law as obtained for the vacuum-tube receiver, given in Eq. (31); its response will be proportional to the first power of the voltage of the received signal, not as the square. This is indicated in Fig. 106.

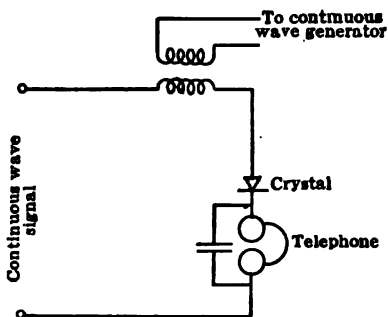

FIG. 105.—A possible scheme for hearing continuous-wave signals with a crystal detector.

The crystal rectifier will also act like the vacuum tube in that the response of the rectifier, for a given signal strength, will vary as the first power of the locally generated e.m.f. until the value of this e.m.f.

is such that the region of parabolic rectification is exceeded. The response of the crystal, for given signal voltage, as the value of E' , is varied is about as shown in Fig. 107; the response is proportional to E' , for a certain range, then ceases to increase with E' , and if E' , is still further

increased the response falls and may reach practically zero for excessively large values of E'_0 .

This same characteristic holds for the vacuum tube used as a beat

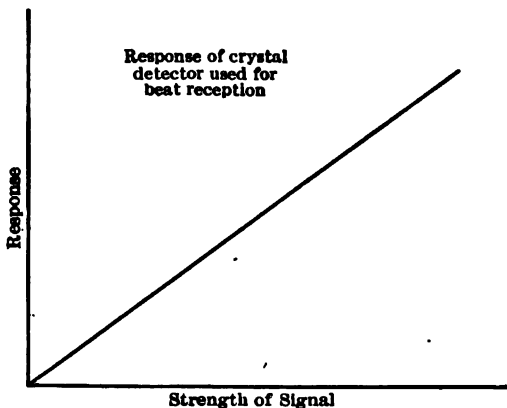

FIG. 106.—Rectifying action of a crystal used as indicated in Fig. 105.

receiver, the static characteristic of a tube being as indicated in Fig. 108; if the amplitude of the locally generated e.m.f. is OC , the response (for given signal strength) will be about twice as strong as if E'_0 had the amplitude OB only, whereas a value of E'_0 equal to OD would result in a signal perhaps less than for $E'_0 = OB$. If E'_0 is increased to the value OE the response to the signal will be practically zero.

Detection with Grid Condenser.—In case a condenser is used in series with the grid of the tube being used as a beat receiver Eq. (18) must be used in predicting the detection efficiency. The question is somewhat more involved than for the tube with no grid condenser, because the normal grid potential (average value with no signal coming in) varies with the value of E'_0 , the potential decreasing as E'_0 is increased in value. As all three of the derivatives used in Eq. (18) vary as the normal grid potential is varied an exact expression for the detection factor must be

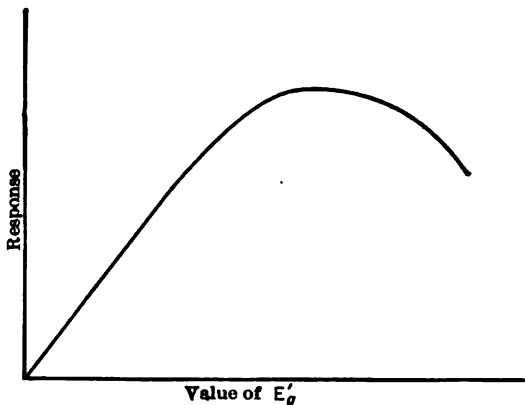

FIG. 107.—Rectifying action of a crystal detector as a function of the amplitude of the locally impressed voltage, the signal voltage being of constant amplitude.

rather complex. As the tube is used in practice the most sensitive condition is easily found as will be described in a succeeding paragraph, dealing with the self-excited, oscillating tube as detector.

Analysis of Some of the More Commonly Employed Circuits for the Self-excited Vacuum-tube Oscillator.—The first circuit to be analyzed is one having a tuned plate circuit, the grid being excited by magnetic coupling with this tuned circuit; the connections are as indicated in Fig. 109. The actual plate current is $I_{op} + i_p$, actual plate voltage $E_{op} + e_p$, and actual grid voltage $E_{og} + e_g$. We suppose that $(E_{op} + \mu_0 E_{og})$ is of such a value that I_{op} is about one-half of the saturation current of the tube

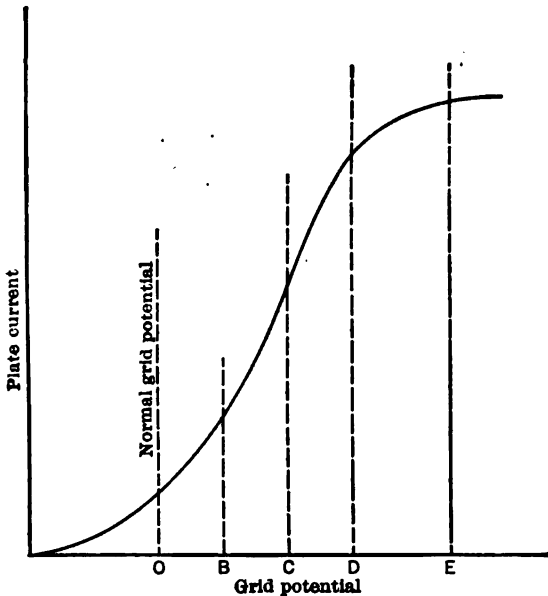

FIG. 108.—The response of a tube used for receiving continuous-wave signals will vary with the strength of the local oscillations, the same as the crystal; a local oscillation of amplitude OC would give (for a fixed incoming signal) response about twice as great as if the amplitude were OB , but an amplitude OE would give but very little response.

is shown and below it in full line the alternating plate current i_p ; the dotted additions to this curve serve to show how i_p differs from a sine wave. The curve i_p shown in Fig. 111 is symmetrical about the zero axis, a condition rarely obtained in an actual tube circuit. It occurs only if the plate-current curve shown in Fig. 110 is symmetrical about the point A . This supposes that the upper part of the curve (caused by saturation) is of the same form as the lower part of the curve (caused by effect of space charge) and also that $(E_{op} + \mu_0 E_{og})$ has been properly adjusted to bring point A to the middle part of the curve.

For such a special state of affairs two effects exist which are practi-

as shown in Fig. 110; when the tube is in the oscillating state the value of $(E_p + \mu_0 E_g)$ fluctuates between OF and OE , and the plate current fluctuates between the values CF and DE . Through this range of fluctuation in the plate current, the relation between I_p and $(E_p + \mu_0 E_g)$ is nearly linear so that

$$i_p = A(e_p + \mu_0 e_g), \quad (32)$$

A being a constant. This relation is not true of course for the extreme values of i_p , the proportionality factor decreasing as the value of i_p approaches the values CF and DE .

This point is illustrated in Fig. 111, in which a sine wave of $(e_p + \mu_0 e_g)$

cally never found in practice; the value of plate current, as read by a continuous-current ammeter, does not change when oscillations begin and the alternating component of the plate current contains no even harmonics. Generally the plate current does change when oscillations are started and the plate current has very pronounced even harmonics.

On the basis of Eq. (32), we can write at once,

$$R_p i_p = e_p + \mu e_g \dots \dots \dots (33)$$

From the notation given in Fig. 109

$$i_p = i_1 + i_2, \dots \dots \dots (34)$$

i_1 being the alternating component of current through L_1 .

Also

$$e_p = -i_1 R_L - L_1 \frac{di_1}{dt}, \dots \dots \dots (35)$$

and

$$e_g = -M \frac{di_1}{dt} \dots \dots \dots (36)$$

To make Eq. (36) true the grid circuit must be so adjusted that no current flows in it as the voltage, e_g , goes through its cycle of values; this requires that at no time throughout the cycle must the grid be positive with respect to the filament, and that the capacity of the grid-filament circuit is negligible.

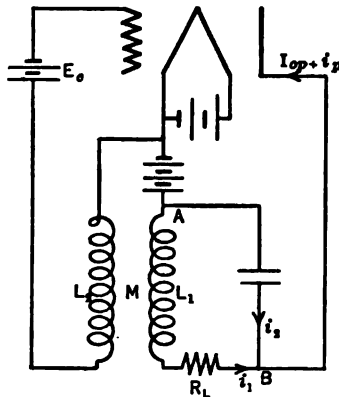

FIG. 109.—A commonly employed circuit for producing oscillations; the frequency is fixed by the constants of the plate circuit and the value of M is the critical factor for production or non-production of oscillations.

In some cases this capacity is of extreme importance; for very high-frequency circuits it may be one of the limiting factors of operation. It must be borne in mind that the capacity to be considered is not the geometrical capacity of the tube, but the *effective capacity* as explained on page 432 et seq. (An oscillating tube furnishes maximum power when the external resistance in the plate circuit is equal to R_p , so in calculating the probable effect of the grid-filament capacity of an oscillating circuit the proper value of μ to use in Eq. (10), p. 434, is $\mu_0/2$.)

We have also

$$i_2 = -C \frac{de_p}{dt},$$

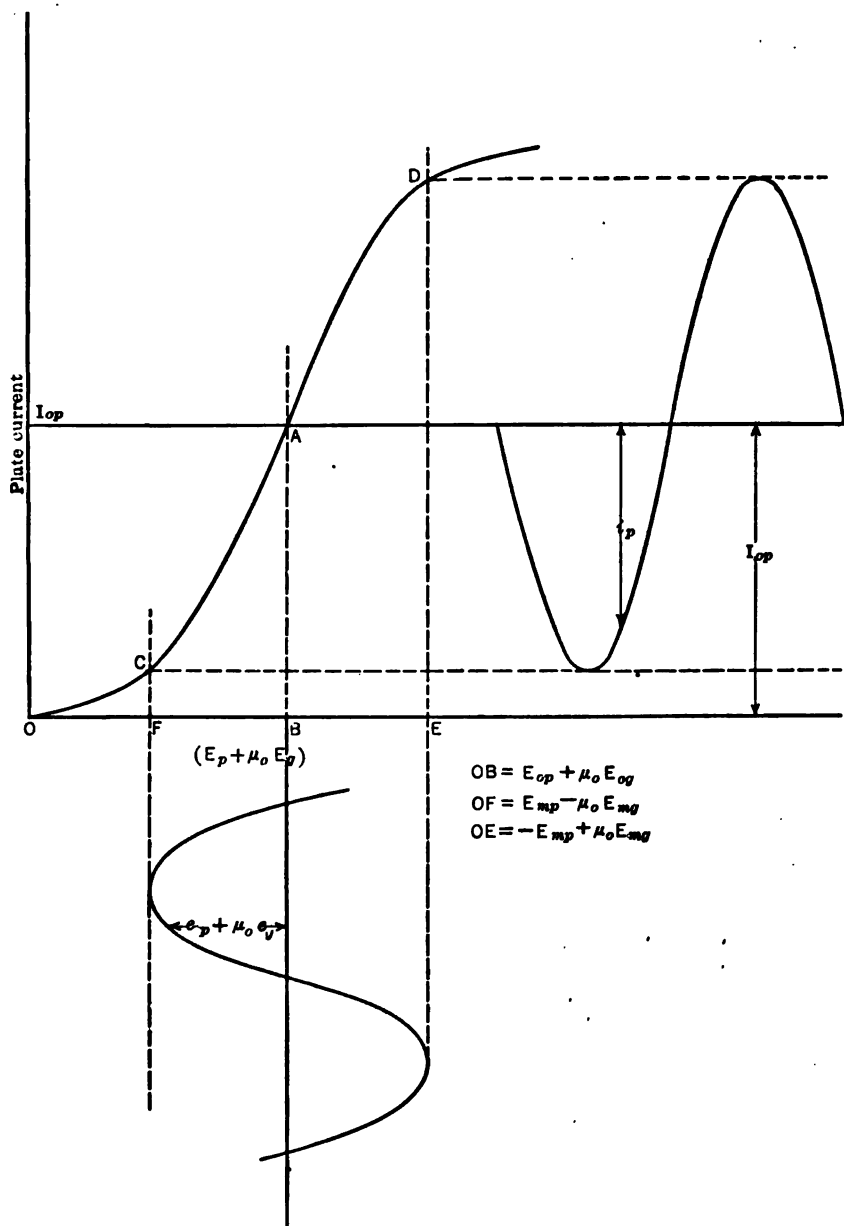

Fig. 110.—A sinusoidal variation in grid potential will produce a sinusoidal variation in plate current only if the fluctuation in plate current occurs over a limited range.

which by using (35) becomes

$$i_2 = CR_L \frac{di_1}{dt} + CL_1 \frac{d^2i_1}{dt^2} \dots \dots \dots (37)$$

By combining the foregoing equations to eliminate e_p , e_g , i_p , and i_2 , we get,

$$L_1 \frac{d^2i_1}{dt^2} + \left[R_L + \frac{1}{CR_p}(L_1 + \mu_0 M) \right] \frac{di_1}{dt} + \frac{i_1}{C} \left(1 + \frac{R_L}{R_p} \right) = 0. \dots (38)$$

Such a differential equation is satisfied by writing i_1 as an exponential function, the form of the function (trigonometric, hyperbolic, etc.), depending upon the relative values of the various constants in Eq. (38).

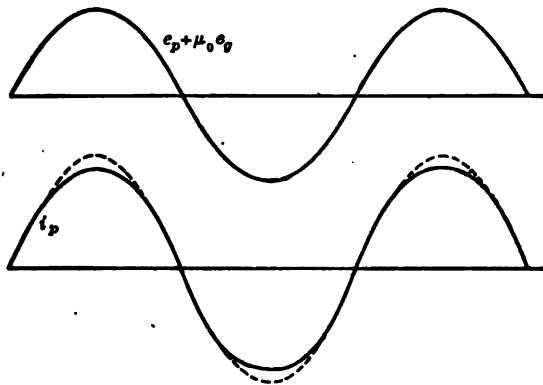

FIG. 111.—Due to the upper and lower curves of the plate current curve of Fig. 110 the actual alternating component of the plate current is flat topped (sine-wave shape shown by dotted lines).

The roots of Eq. (38) are real if we have,¹

$$\left[R_L + \frac{1}{CR_p}(L_1 + \mu_0 M) \right]^2 - \frac{4L_1}{C} \left(1 + \frac{R_L}{R_p} \right) > 0. \dots (39)$$

For this condition, the current i_1 must be non-oscillatory, the circuit is aperiodic. If $R_L + \frac{1}{CR_p}(L_1 + \mu_0 M) > 0$, the exponential function is a decreasing one and in case some disturbance occurs in the circuit the disturbance soon disappears and the circuit resumes its normal condition. This can evidently occur if M is positive and also if M is negative provided its value is less than $\frac{1}{\mu_0}(L_1 + CR_L R_p)$.

If $R_L + \frac{1}{CR_p}(L_1 + \mu_0 M) < 0$, any disturbance set up in the system tends

¹ For an analysis of an equation of this kind see the first few pages of Chapter IV.

to increase itself; this occurs if M is negative and its value such that $M > \frac{1}{\mu_0} (L_1 + CR_L R_p)$. The plate current then tends to increase or decrease (according to the sense of this disturbance) and does so as long as the characteristic curve (Fig. 110) is straight.

In the case the constants of Eq. (38) are such as to make its roots imaginary, we have,

$$\left[R_L + \frac{1}{CR_p} (L_1 + \mu_0 M) \right]^2 - \frac{4L_1}{C} \left(1 + \frac{R_L}{R_p} \right) < 0. \quad (40)$$

The current i_1 must then be of the form,

$$i_1 = A e^{\alpha t} \sin (\omega t + \theta), \quad (41)$$

in which, we must have

$$\alpha = -\frac{1}{2L_1} \left[R_L + \frac{1}{CR_p} (L_1 + \mu_0 M) \right], \quad (42)$$

and

$$\omega = \frac{1}{2L_1} \sqrt{\frac{4L_1}{C} \left(1 + \frac{R_L}{R_p} \right) - \left[R_L + \frac{1}{CR_p} (L_1 + \mu_0 M) \right]^2}. \quad (43)$$

The exponential in Eq. (41) is decreasing if $R_L + \frac{1}{CR_p} (L_1 + \mu_0 M) > 0$, which is true for all positive values of M , or if M is negative, but its value is such that $M < \frac{1}{\mu_0} (L_1 + CR_L R_p)$.

For such conditions any shock on the circuit will produce oscillations, of frequency as determined from Eq. (43), but the oscillations will die away because of the negative value of α .

The last, and most important, case to consider is given by

$$R_L + \frac{1}{CR_p} (L_1 + \mu_0 M) < 0,$$

that is, when M is negative and its absolute value is such that,

$$M > \frac{1}{\mu_0} (L_1 + CR_L R_p). \quad (44)$$

For this condition any disturbance to the circuit will start oscillations, and these oscillations will increase in magnitude until the straight part of the curve in Fig. 110 is exceeded.

The effect of making the plate current fluctuate through such large values is to make R_p variable throughout the cycle, resulting also in an increase in the average value of R_p ; the oscillations will therefore increase in amplitude, after once being started, until the value of R_p is increased to such an extent that the inequality given in Eq. (44) is changed to an

equality. When this condition is brought about the value of α becomes zero, and the exponential in Eq. (41) reduces to unity, giving neither increase or decrease in the amplitude of the current.

From the foregoing it is evident that if the circuit of Fig. 109 is to produce oscillations, M must be somewhat greater than its *critical value* given by the relation

$$-M = \frac{1}{\mu_0} (L_1 + CR_L R_p). \quad \dots \dots \dots (45)$$

If M exceeds (in absolute value) this value oscillation will start: if oscillations are already present and M is made slightly less than this value (in absolute magnitude), the oscillations will stop, hence the use of the term *critical value*.

The frequency of the oscillations is obtained from Eq. (43) and is,

$$f = \frac{1}{2\pi L_1} \sqrt{\frac{4L_1}{C} \left(1 + \frac{R_L}{R_p}\right) - \left[R_L + \frac{1}{CR_p} (L_1 + \mu_0 M)\right]^2}, \quad \dots \dots (46)$$

and if M is adjusted to its critical value,

$$f = \frac{1}{2\pi} \sqrt{\frac{1 + \frac{R_L}{R_p}}{L_1 C}}, \quad \dots \dots \dots (47)$$

which in the average radio circuit is practically the same as,

$$f = \frac{1}{2\pi \sqrt{L_1 C}}. \quad \dots \dots \dots (48)$$

If the coupling between the grid and plate circuits is made tighter than required for the limiting value, the frequency is somewhat decreased.

If we suppose Eq. (48) to give the frequency the critical value of M may be written in the form,

$$-M = \frac{L_1}{\mu_0} \left(1 + \frac{R_L R_p}{(\omega L_1)^2}\right) = \frac{C}{\mu_0} \left(\frac{1}{(\omega C)^2} + R_L R_p\right). \quad \dots \dots (49)$$

From this relation it is evident that if a circuit is oscillating with a value of M equal to the critical value any decrease in the frequency, accomplished by varying either L_1 or C , must be accompanied by an increase in the coupling, otherwise the oscillations will cease.

Prediction of Oscillatory Condition by Putting Total Resistance Equal to Zero.—The condition for oscillations in any circuit can be expressed by putting the total resistance of the circuit equal to zero. In Fig. 109 the external plate circuit has a resistance R_{A-B} and this is in series with the effective tube resistance R'_p . This R'_p is the relation between e_p and i_p , when the values of i_p are determined not only by e_p but by the simultaneously acting e_g ; as e_g may be 180° out of phase with e_p and of such value

that $\mu_0 e_p > e_p$, it is possible to have i_p 180° out of phase with e_p , so that R'_p may be negative, whereas R_p is always positive.¹ We have then as the condition, for self-sustained oscillations

$$R_{A-B} + R'_p = 0. \quad \dots \quad (50)$$

From Eq. (50), Chapter I, we find that at resonance,

$$R_{A-B} = \frac{L_1}{C} \frac{1}{R_L}. \quad \dots \quad (51)$$

Now $e_s = \omega M i_1$, $e_p = \omega L_1 i_1$, and $i_p = \frac{1}{R_p} (e_p + \mu_0 e_s)$.

$$R'_p = \frac{e_p}{i_p} = \frac{\omega L_1 i_1}{\frac{1}{R_p} (\omega L_1 i_1 + \mu_0 \omega M i_1)} = \frac{R_p L_1}{L_1 + \mu_0 M}. \quad \dots \quad (52)$$

Hence using Eq. (50), the critical value of M may be obtained from the relation,

$$\frac{R_p L_1}{L_1 + \mu_0 M} + \frac{L_1}{C} \frac{1}{R_L} = 0. \quad \dots \quad (53)$$

If we use the approximate relation $C = \frac{1}{\omega^2 L_1}$, Eq. (53) yields the solution,

$$-M = \frac{L_1}{\mu_0} \left(1 + \frac{R_L R_p}{(\omega L_1)^2} \right), \quad \dots \quad (54)$$

which is the same as obtained in Eq. (49).

Phases of Voltages and Currents in the Steady State.—When the value of M , being increased from zero, slightly exceeds the critical value as determined by Eq. (45), oscillations start and build up to a certain steady value; how quickly they reach the steady state depends upon how much M exceeds its critical value, when the oscillations start and on the value of R_L . The steady state is reached when R_p has sufficiently increased (in average value) to reduce (45) to an equality.

When
$$R_L + \frac{1}{C R_p} (L_1 + \mu_0 M) = 0,$$

¹ This difference between R_p and R'_p may be indicated by writing $R_p = \frac{\delta e_p}{\delta i_p}$ and $R'_p = \frac{d e_p}{d i_p}$; for the latter case it must be remembered that as e_p changes e_s undergoes simultaneous changes which may result in the total derivative $\frac{d e_p}{d i_p}$ being negative whereas the partial derivative $\frac{\delta e_p}{\delta i_p}$ is always positive.

Eq. (38) reduces to the form,

$$L_1 \frac{d^2 i_1}{dt^2} + \frac{i_1}{C} \left(1 + \frac{R_L}{R_p} \right) = 0. \dots \dots \dots (55)$$

The solution of this is $i_1 = I_1 \sin \omega t$, in which

$$\omega = \sqrt{1 + \frac{R_L}{R_p}} \cdot \frac{1}{L_1 C}.$$

The grid voltage $e_g = -M \frac{di_1}{dt} = -\omega M I_1 \cos \omega t$.

But as M is negative, this may be written,

$$e_g = \omega M I_1 \sin \left(\omega t + \frac{\pi}{2} \right), \dots \dots \dots (56)$$

which makes the grid voltage lead the current I_1 by 90° .

The plate voltage

$$\begin{aligned} e_p &= -R_L i_1 - L_1 \frac{di_1}{dt} = -R_L I_1 \sin \omega t - \omega L_1 I_1 \cos \omega t \\ &= -I_1 \sqrt{R_L^2 + (\omega L_1)^2} \sin (\omega t + \phi), \end{aligned}$$

in which
$$\tan \phi = \frac{\omega L_1}{R_L}.$$

In practically all radio coils $\frac{\omega L_1}{R_L}$ is so large that ϕ may be put equal to 90° without much error, so that,

$$e_p = -I_1 \sqrt{R_L^2 + (\omega L_1)^2} \sin (\omega t + \pi/2). \dots \dots \dots (57)$$

From (56) and (57) it is evident that e_p and e_g are practically 180° out of phase, a condition we have previously shown necessary for oscillation.

The plate current is fixed by the condition,

$$e_p = -R_L i_1 - (L_1 + \mu_0 M) \frac{di_1}{dt}.$$

As $e_p = R_p i_p$, we have,

$$\begin{aligned} i_p &= -\frac{R_L}{R_p} i_1 - \frac{L_1 + \mu_0 M}{R_p} \frac{di_1}{dt} = -\frac{R_L}{R_p} I_1 \sin \omega t - \frac{L_1 + \mu_0 M}{R_p} \omega I_1 \cos \omega t \\ &= -\frac{I_1}{R_p} \sqrt{R_L^2 + \omega^2 (L_1 + \mu_0 M)^2} \sin (\omega t + \psi), \end{aligned}$$

in which

$$\tan \psi = \frac{\omega (L_1 + \mu_0 M)}{R_L}.$$

As M is negative and $\mu_0 M$ is greater in absolute value than L_1 , the angle ψ is nearly $-\frac{\pi}{2}$.

Then

$$i_p = -\frac{I_1}{R_p} \sqrt{R_L^2 + \omega^2(L_1 + \mu_0 M)^2} \sin(\omega t - \pi/2)$$

$$= \frac{I_1}{R_p} \sqrt{R_L^2 + \omega^2(L_1 + \mu_0 M)^2} \sin(\omega t + \pi/2). \quad (58)$$

It is therefore evident that the plate current leads the current in L_1 by practically 90° .

Amplitude of Oscillation in the Steady State.—The greatest current is obtained in the oscillating circuit with the least coupling that can be used to maintain oscillations. The lower the value of M the greater must I_1 be to maintain the required grid excitation and I_1 will vary with M about as shown by the full line curve in Fig. 112; if the value of M is decreased beyond the critical value oscillations will generally cease entirely. In certain tubes it is possible, however, to get maximum current with somewhat greater coupling than that at which oscillations start; in that case the curve between M and I_1 has the form indicated by the dotted line. The form depends upon the static characteristic; in Fig. 113 are shown two possible curves. The full-line curve corresponds with the full-line curve of Fig. 112, and the dotted curve of 113 corresponds to the dotted curve in Fig. 112.

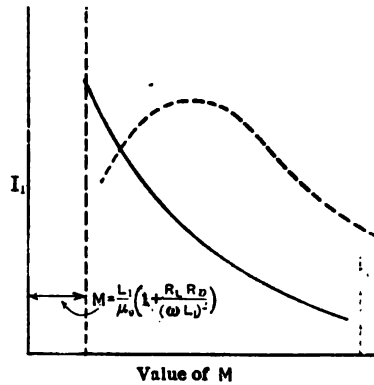

FIG. 112.—Showing possible relations between amplitude of oscillatory current and value of M in Fig. 109; the dotted line curve shows the ordinary condition. (See Figs. 178 and 179 of this chapter.)

If the value I_{op} (no oscillations) is so adjusted that it is equal to one-half the saturation current, then the maximum possible value of i_p is I_{op} . But from Eq. (58) we have the maximum value of i_p given by the relation

$$I_{mp} = \frac{I_{m1}}{R_p} \sqrt{R_L^2 + \omega^2(L_1 + \mu_0 M)^2},$$

I_{mp} and I_{m1} being the maximum possible values of the effective values of i_p and i_1 , and this value of I_{mp} must be equal to I_{op} . So we put,

$$I_{op} = \frac{I_{m1}}{R_p} \sqrt{R_L^2 + \omega^2(L_1 + \mu_0 M)^2},$$

or
$$I_{m1} = \frac{I_{op}R_p}{\sqrt{R_L^2 + \omega^2(L_1 + \mu_0 M)^2}}$$

and by substituting the condition

$$(L_1 + \mu_0 M) = -CR_pR_L$$

and assuming

$$\omega = \sqrt{\frac{1}{L_1 C}}$$

$$I_{m1} = \frac{I_{op}}{R_L} \frac{1}{\sqrt{\frac{C}{L_1} + \frac{1}{R_p^2}}}$$

which for the average tube is practically the same as,

$$I_{m1} = \frac{I_{op}}{R_L} \sqrt{\frac{L_1}{C}} \dots \dots \dots (59)$$

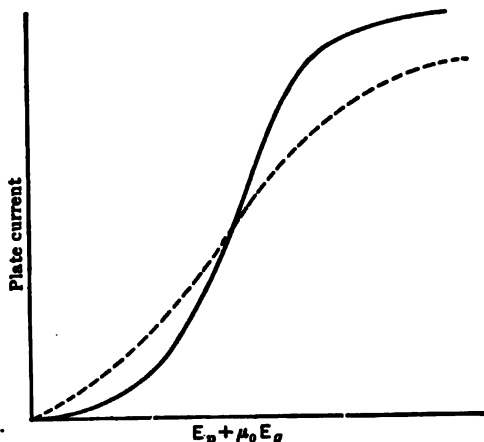

Fig. 113.—A tube having a plate current curve as shown by the full line will behave as indicated for the full line of Fig. 112; similarly for the dotted lines.

For this condition we conclude that increasing C must result in a decrease in I_1 , but in trying out this relation experimentally we often find that I_1 may be increased by increasing C . There must be in the circuit some other limitation which must also be considered in using the relation of Eq. (59). Indeed this is at once evident, because Eq. (59) would lead to a value of I_1 , approaching infinity as C is made to approach zero.

By examining the possible values of e_p , we find the other limiting factor; it is

evident that the maximum value of e_p is E_{op} , so that we have as another limiting condition on the amplitude of the oscillating current,

$$E_{op} = I_{m1} \sqrt{R_L^2 + (\omega L_1)^2}$$

This follows from Eq. (57), putting the maximum value of e_p equal to E_{op} . We then have,

$$I_{m1} = \frac{E_{op}}{\sqrt{R_L^2 + (\omega L_1)^2}}$$

which for critical value of M and assuming

$$\omega = \sqrt{\frac{1}{L_1 C}}$$

gives,

$$I_{m1} = \frac{E_{op}}{\sqrt{\frac{L_1}{C} + R_L^2}}$$

and as the value of R_L^2 is ordinarily small compared to $\frac{L_1}{C}$, we have as another limitation on the value of the oscillating current,

$$I_{m1} = E_{op} \sqrt{\frac{C}{L_1}} \dots \dots \dots (60)$$

Eqs. (59) and (60) then constitute two limits on the possible amplitude of I_1 ; whichever gives the lower value will determine the maximum value of I_1 . The best condition makes the two limits the same which occurs when

$$\frac{E_{op}}{I_{op}} = \frac{1}{R_L} \frac{L_1}{C} \dots \dots \dots (61)$$

The symbols I_{op} and E_{op} have been used to indicate the limiting values of i_p and e_p , so that Eq. (61) is properly written, using effective values of voltage and current.

$$\frac{\text{maximum value } E_p}{\text{maximum value } I_p} = \frac{1}{R_L} \frac{L_1}{C} \dots \dots \dots (62)$$

But from Eq. (50), Chapter I,

$$\frac{1}{R_L} \frac{L_1}{C} = R,$$

the external resistance of the plate circuit, and

$$\frac{\text{maximum value of } E_p}{\text{maximum value of } I_p}$$

is really R_p , the internal resistance of the tube.

The foregoing analysis therefore yields the same result as obtained on page 471, namely, for maximum output the external resistance of the tube circuit should be equal to the tube resistance itself.

By comparing Eqs. (62) and (61), it is seen that the resistance of the tube for maximum output is equal to $\frac{E_{op}}{I_{op}}$, which we previously called R_{op} , the continuous-current resistance of the tube. We also showed that R_p , the alternating-current resistance, was generally about one-half the continuous-current resistance R_{op} (Eq. (7) and Fig. 48). This apparent discrepancy arises from the fact that R_p is really a variable quantity, depend-

ing for its value upon the amount of change in the plate current. The discussion of R_p on page 471 et seq. and the measurements recorded in Fig. 94 had to do with R_p for very small variations in plate current, and in such a case R_{op} is about twice as great as R_p .

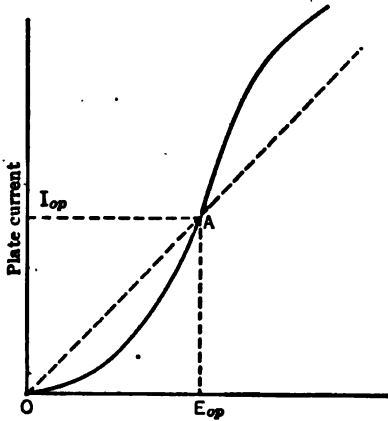

FIG. 114.—If the R_p of a tube is to be constant the relation between I_p and $(E_p + \mu_0 E_g)$ must be a straight line as indicated in the dotted graph; actually the solid line curve gives the plate current, hence it is evident that R_p must vary with the magnitude of fluctuation of $(E_p + \mu_0 E_g)$.

For the conditions obtaining when Eqs. (61) and (62) are applicable, the plate current is supposed to vary from zero to $2 I_{op}$, and furthermore the relation between I_p and $(E_p + \mu_0 E_g)$ is supposed to be linear; for such conditions $R_p = R_{op} = \frac{E_{op}}{I_{op}}$. The difference in R_p with weak excitation and strong excitation is indicated in Fig. 114; the full-line curve represents the actual relation between I_p and E_p when there is no resistance in series with the plate circuit and the dotted curve shows the assumed relation on the basis of Eq. (33). The dotted line curve gives for R_p (at point A)

$$\frac{\Delta E_p}{\Delta I_p} = \frac{E_{op}}{I_{op}},$$

whereas the full line curve gives for R_p at the point A a value of $\frac{\Delta E_p}{\Delta I_p}$ about half as great as $\frac{E_{op}}{I_{op}}$.

Of course, it is not possible to excite a tube to the limits set by Eqs. (59) and (61), so R_p actually never increases to the value

$$R_p = \frac{E_{op}}{I_{op}};$$

as the intensity of the oscillations varies; the value of R_p for the ordinary tube will undergo changes about as shown in Fig. 115.

Stability of Oscillations.—In the average circuit the value of the oscillating current is greatest when the coupling is as weak as can be permitted and still maintain oscillations. For this condition, however, the stability of the circuit is very poor; the slightest decrease in either I_f or E_b is likely to stop the oscillations. Also for this condition it is necessary to readjust the coupling for every change in the oscillating circuit; if either R_L , L_1 , or C is increased the oscillation will cease. To

make this circuit stable it is necessary to have the coupling at a setting considerably in excess of its critical value, perhaps twice as much. This of course will diminish somewhat the magnitude of the oscillating current, but the increased reliability of the generating action of the tube generally compensates for this.

It many times happens that the critical value of coupling for starting oscillations is greatly different from the critical value to stop oscillations; in a certain circuit this critical value of coupling for starting the oscillations was 17 per cent, whereas it could then be decreased to 12 per cent before the oscillations

ceased. This is due to the variable value of R_p , as brought out in a previous paragraph; when the oscillations start their amplitude is necessarily small and R_p is determined

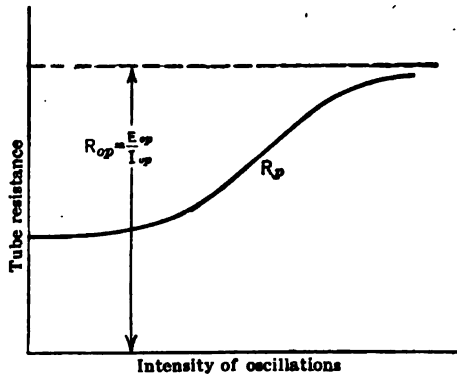

FIG. 115.—The resistance of the plate circuit of a tube varies with the fluctuation of $(E_p + \mu_0 E_g)$ about as shown here; intense oscillations require large fluctuations in $(E_p + \mu_0 E_g)$.

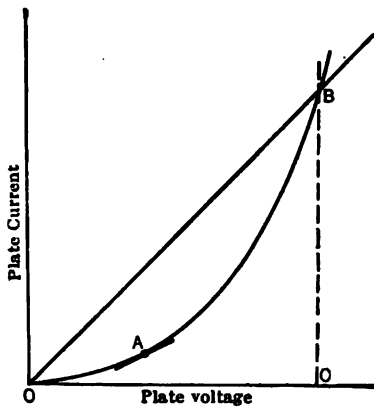

FIG. 116.—When a tube starts to oscillate its resistance is fixed by the slope of the $I_p - E_p$ curve, and this resistance may be very different from the value when intense oscillations are occurring.

by the slope at the value of I_p , as shown in Fig. 116 at A. After the oscillations are started, the plate current fluctuates between 0 and BC, and the average resistance between these limits is less than the value of R_p at A. The plate current for such oscillations would be very complex and so the behavior of the circuit could not be predicted from the analyses previously given, which have assumed sine waves of current.

Starting and Stopping Oscillations.—It is sometimes necessary to give a circuit some sort of a shock to start oscillations; if normal filament current and plate voltage are impressed and then the coupling gradually

increased, it will be found that M may greatly exceed its critical value without causing the tube to oscillate. If, however, the plate circuit is opened and then closed, thus giving a pulse to the circuit, oscillations will start.

In case a tube is used for generating power in a transmitting station, the oscillations must be continually started and stopped, as the signals are sent out by the key. The vacuum-tube generator permits this operation to be carried out readily; a small hand key properly introduced

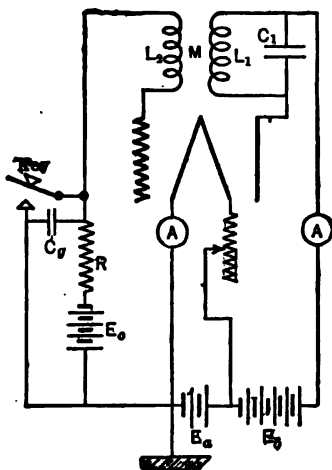

FIG. 117.—This diagram shows a convenient method of "keying" a tube circuit; if the proper values of R and E_c are chosen a small hand key may control kilowatts of power with imperceptible sparking.

the starting of the oscillations will not occur as soon as the key is depressed; about 0.1 microfarad seems satisfactory when R is 20,000 ohms.

Effects of Oscillation on the Grid and Plate Currents.—In such a circuit as that shown in Fig. 109, the grid current is very nearly zero until oscillations start; when the tube is oscillating the grid becomes positive during part of the cycle and so takes current. The value of the grid current is larger than would be at first supposed, because, although the grid potential does not reach high positive values, the plate potential is low at the time the grid is positive.

In a small power tube designed for $E_b = 300$ and $E_{op} = .04$ ampere the average value of I_g when the tube is adjusted for maximum value of power output is about .003 ampere. The maximum value of the grid current, when its average value is .003, is probably from .02 to .05 ampere. In a large power tube, excited for maximum power output, I_g may be considerably greater than the values given above.

If the plate current I_{op} has been adjusted equal to half the saturation current, for the values of I_f and E_{op} used, a continuous-current ammeter will indicate no change in the value of the plate current when oscillations start. In general, however, there will be a change; when oscillations start the average plate current will generally increase if the circuit is such that no condenser is used in series with the grid and will decrease if such a condenser is used. Conditions may occur in which this general statement is not true.

Adjustments to Give Maximum Output of Tube.—With a circuit arranged as in Fig. 109, there are two adjustments to carry out before the tube will give its maximum output; the grid must have the proper excitation and the plate circuit resistance must equal the tube resistance. The circuit of Fig. 109 is reproduced, with slight modification, in Fig. 118. The oscillating circuit L_1, R_L, C , is many times an antenna, with loading coil, so it is evident that R_L itself is not adjustable, yet the resistance between points A and O must be made equal to the tube resistance.

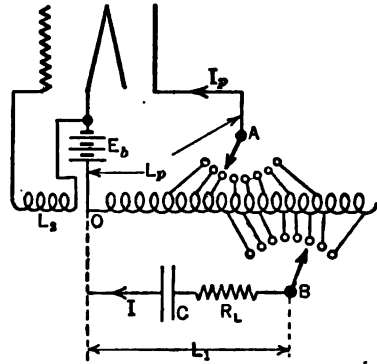

FIG. 118.—To make the circuit shown in Fig. 109 useful, the inductance in the oscillatory circuit must be fitted with two sets of taps as indicated here; the mutual induction between the two coils L_2 and L_p must also be adjustable.

The plate circuit inductance is made with taps as indicated in Fig. 118; point B is adjusted to give the right frequency to the oscillating circuit, and then point A is adjusted to give the plate circuit the right resistance. Neglecting the effect of the plate current compared to the oscillating current (an ordinary radio set makes I_p equal to about 1/20 of I), we have,

$$R_{O-A} = R_L \left(\frac{\omega L_p}{R_L} \right)^2 = \frac{\omega^2 L_p^2}{R_L} = \frac{L_p^2}{R_L L_1 C}$$

If R_{O-A} is to be equal to $R_p = \frac{E_{op}}{I_{op}}$ (for conditions of maximum power) we so adjust tap A that

$$\frac{E_{op}}{I_{op}} = \frac{L_p^2}{R_L L_1 C}$$

or

$$L_p = \sqrt{\frac{E_{op} R_L L_1 C}{I_{op}}} \dots \dots \dots (63)$$

This required value of L_p may be either greater or less than L_1 .

In a certain radio circuit $R_L = 3$ ohms, $C = 4 \times 10^{-10}$ farads, $L_1 = 150 \mu h$. $E_{op} = 300$ volts, $I_{op} = .03$ ampere. Using Eq. (63), the required value of L_p proves to be $42 \mu h$. The tap A would therefore be made between O and tap B .

The current in the oscillating circuit can be calculated from the relation $I = \omega CE$, where E is the effective voltage across OB , which is equal to $\frac{E_{op}}{\sqrt{2}} \times \frac{L_1}{L_p}$.¹ Using these relations and also remembering that $\omega = \sqrt{\frac{1}{L_1 C}}$ we get,

$$I = \frac{E_{op}}{L_p} \sqrt{\frac{L_1 C}{2}} = \sqrt{\frac{E_{op} I_{op}}{2 R_L}} \quad (64)$$

Substituting the values above gives a value for I of 1.23 amperes. Actually 1.05 amperes was the maximum obtainable from the circuit.

The resistance R_L was then increased to 50 ohms, and it was found experimentally that tap A was outside of tap B for maximum output. By calculation, Eq. (63), we find the proper value for $L_p = 171 \mu h$. The oscillatory current, from Eq. (64), should be 0.31 ampere, whereas only 0.26 was actually obtained.

After the right position for tap A has been found the coupling between L_2 and L_1 , is reduced until the critical value of M is nearly reached, and then a slight readjustment of tap A may be necessary. It will be found that varying M and the position of tap A will have only minor effects on the frequency being generated by the tube.

The value of L_2 should be kept as low as possible; if it should happen that the natural period of L_2 , combined with the capacity of the input circuit of the tube is about the same as the period of the $L_1 C$ circuit, trouble may be experienced in making the tube oscillate because of the unexpected phase of the voltage impressed on the grid; the voltage changes its phase nearly 180° as the natural frequency of the $L_1 C$ circuit is made to pass through the natural frequency of the grid circuit.

Oscillations at Other than the Desired Frequency.—It may happen that if the grid circuit has its natural frequency in the neighborhood of the frequency of the $L_1 C$ circuit the tube will generate power of the frequency of the grid circuit, instead of that of the $L_1 C$ circuit.

¹ This relation is approximate only, because of the mutual induction between the inductance between points $O-A$ (Fig. 118) and that between points $A-B$. If the coil is short, so that the turns are all close together, the effect of this mutual induction will be considerable and the relation given above is more accurately written $\frac{E_{op}}{\sqrt{2}} \times \frac{N_1}{N_2}$ where

N_1 = number of turns between points $O-B$

and

N_2 = number of turns between points $O-A$.

To remedy this trouble the grid circuit is sometimes tuned to the same frequency as the L_1C circuit. Another method of ensuring the desired frequency of oscillations is to couple the grid, not to the plate coil, but to a coil in the L_1C circuit, which is so placed that no current flows in it unless the main circuit is oscillating. This idea is depicted in Fig. 119. Coil L_1 will carry no current unless the main circuit, including L_1 and C , is oscillating.

The difficulty occurs principally when the resistance of the main oscillating circuit is high so that the current I is relatively small; to sufficiently excite the grid in this case requires a comparatively large value of L_2 , which of course lowers the natural period of the grid circuit.

Oscillating Current Comparable in Value with Plate Current.—When the resistance of the oscillating circuit gets very high the oscillating current I may decrease to such an extent that it is of about the same value as I_p , or even less.

In this case it is not easy to produce oscillations, because the e.m.f. for the excitation on the grid tends to get the wrong phase. The scheme of Fig. 119 may not work because L_1 , which must be small compared to L_p (because of the high value of R_L), may not induce a sufficient voltage in L_2 , so resort must be had to coupling L_2 with L_p . Now the oscillatory current in L_p is ordinarily 90° out of phase (nearly) with I_p , and such condition results in a correct phase for the voltage E_g . But if now I_p is comparable with I , the actual current in L_p (which produces the magnetic field affecting L_2) tends to come into phase with I_p , that is, shift its phase 90° from its normal value. But such a shift in phase will result in such a phase for E_g that oscillations cannot be maintained; in fact a comparatively small shift will materially cut down this possible power output of the tube.

For a condition of this sort it is better to use separate excitation for the tube, instead of trying to make it self-exciting. Another tube circuit, having a low resistance, is self-excited at the desired frequency, and from this circuit a suitable voltage may be obtained (either directly or magnetically) for excitation of the tube furnishing power to the high resistance circuit.

Coupling between Grid and Plate Circuit by Capacity.—In the foregoing discussions of a self-excited tube the voltage for excitation of the grid has been obtained by a magnetic coupling with the oscillating circuit,

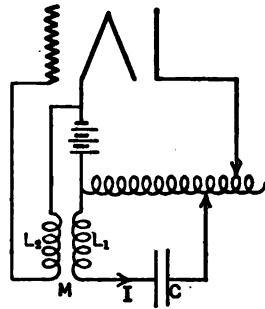

FIG. 119.—To prevent spurious oscillations it is advisable to couple the grid circuit to some part of the main oscillatory circuit through which the plate current does not flow; the grid is then not excited unless the main circuit is oscillating.

but it is of course possible to use electrostatic coupling, or even a combination of both. Such a circuit is shown in Fig. 120; in order to make the discussion more general only a part of the inductance in the oscillating circuit is included in the plate circuit. The extra inductance L_2 , in combination with C_2 and R , represents an antenna, thus making the circuit

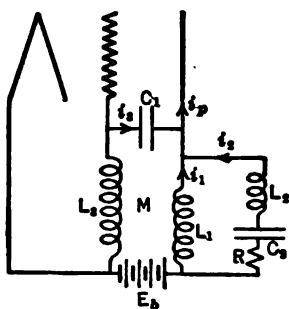

FIG. 120.

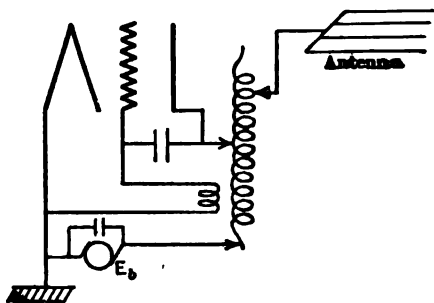

FIG. 121.

FIG. 120.—Another oscillatory circuit in which the grid is excited by inductive coupling between L_1 and L_2 as well as by the capacitive coupling produced by C_1 .

FIG. 121.—Showing how the circuit of Fig. 120 is applied to an actual radio circuit.

the direct equivalent of the actual circuit shown in Fig. 121. From Fig. 120 using directions of current shown in the diagram, we have,

$$i_p = i_1 + i_2 + i_3. \quad \dots \dots \dots (65)$$

$$-L_1 \frac{di_1}{dt} - M \frac{di_3}{dt} = -L_2 \frac{di_2}{dt} - Ri_2 + e_{C_2} = -L_3 \frac{di_3}{dt} - M \frac{di_1}{dt} + e_{C_1}. \quad (66)$$

Also we know that e_{C_1} and e_{C_2} are fixed by the relation $-C_2 \frac{de_{C_2}}{dt} = i_2$, and $-C_1 \frac{de_{C_1}}{dt} = i_3$. By the use of these relations, and deriving Eq. (65), we get the equations,

$$L_1 \frac{d^2 i_1}{dt^2} + M \frac{d^2 i_3}{dt^2} = L_2 \frac{d^2 i_3}{dt^2} + R \frac{di_2}{dt} + \frac{i_2}{C_2}. \quad \dots \dots \dots (67)$$

$$(L_1 - M) \frac{d^2 i_1}{dt^2} = (L_3 - M) \frac{d^2 i_3}{dt^2} + \frac{i_3}{C_1}. \quad \dots \dots \dots (68)$$

We can write

$$R_p i_p = e_p + \mu_0 e_g; \quad e_p = -L_1 \frac{di_1}{dt} - M \frac{di_3}{dt}; \quad e_g = -L_3 \frac{di_3}{dt} - M \frac{di_1}{dt}.$$

Using these conditions, and Eq. (65), we get,

$$R_p (i_1 + i_2 + i_3) + (L_1 + \mu_0 M) \frac{di_1}{dt} + (\mu_0 L_3 + M) \frac{di_3}{dt} = 0. \quad \dots \dots (69)$$

Eqs. (67), (68) and (69) permit the precise determination of i_1 , i_2 , and i_3 , but it is evident that the solution would be tedious and the solution can be easily guessed. If oscillations occur at all they will be sinusoidal and as they are all supplied with power from the same source (the plate circuit) we can write,

$$i_1 = I_1 \sin \omega t, i_2 = I_2 \sin (\omega t + \phi_2), i_3 = I_3 \sin (\omega t + \phi_3).$$

By deriving these expressions and substituting in Eqs. (67), (68) and (69), and for each equation thus obtained, equating the coefficients of $\cos \omega t$ and $\sin \omega t$, we find

$$R_p(I_1 + I_2 \cos \phi_2 + I_3 \cos \phi_3) - \omega(\mu_0 L_3 + M) I_3 \sin \phi_3 = 0. \quad (70)$$

$$R_p(I_2 \sin \phi_2 + I_3 \sin \phi_3) + \omega(L_1 + \mu_0 M) I_1 + \omega(\mu_0 L_3 + M) I_3 \cos \phi_3 = 0. \quad (71)$$

$$\omega L I_1 + \omega M I_3 \cos \phi_3 = \left(\omega L_2 - \frac{1}{\omega C_2} \right) I_2 \cos \phi_2 + I_2 R \sin \phi_2. \quad (72)$$

$$\omega M I_3 \sin \phi_2 = \left(\omega L_2 - \frac{1}{\omega C_2} \right) I_2 \sin \phi_2 - I_2 R \cos \phi_2. \quad (73)$$

$$\omega(L_1 - M) I_1 = \left\{ \omega(L_3 - M) - \frac{1}{\omega C_1} \right\} I_3 \cos \phi_3. \quad (74)$$

$$\left\{ \omega(L_3 - M) - \frac{1}{\omega C_1} \right\} I_3 \sin \phi_3 = 0. \quad (75)$$

Eq. (75) shows that unless $\omega(L_3 - M) - \frac{1}{\omega C_1} = 0$, $\sin \phi_3$ must be equal to zero, which means that e_3 and i_3 are either in phase or 180° out of phase.

In case $\omega(L_3 - M) - \frac{1}{\omega C_1} = 0$, we have resonance in the $L_3 - C_1$ circuit.

Using Eqs. (74) and (75) to get values of $\sin \phi_3$ and $\cos \phi_3$, then using Eqs. (70) and (71) to get values of $\sin \phi_2$ and $\cos \phi_2$ and putting these values in Eqs. (72) and (73), we get the two equations

$$\left(\omega(L_1 + L_2) - \frac{1}{\omega C_2} \right) + \left\{ \omega(L_2 + M) - \frac{1}{\omega C_2} \right\} \frac{\omega(L_1 - M)}{\omega(L_3 - M) - \frac{1}{\omega C_1}} + \frac{R}{R_p} \left\{ \omega(L_1 + \mu_0 M) + \omega^2 \frac{(L_1 - M)(\mu_0 L_3 + M)}{\omega(L_3 - M) - \frac{1}{\omega C_1}} \right\} = 0, \quad (76)$$

and

$$R - \frac{\omega L_2 - \frac{1}{\omega C_2}}{R_p \left\{ 1 + \frac{\omega(L_1 - M)}{\omega(L_3 - M) - \frac{1}{\omega C_1}} \right\}} \left\{ \omega(L_1 + \mu_0 M) + \omega^2 \frac{(L_1 - M)(\mu_0 L_3 + M)}{\omega(L_3 - M) - \frac{1}{\omega C_1}} \right\} = 0. \quad (77)$$

The frequency might be calculated from Eq. (76), and this frequency carried into Eq. (77) would permit the calculation of the critical coupling for oscillations. From inspection of Fig. 111 it is evident there will be two possible frequencies and of course each of these must be used in solving Eq. (77). This general solution is lengthy, so we will investigate only two of the more important cases.

In case $C_1=0$ and $L_2=0$, the circuit degenerates into that of Fig. 109 and so our general Eqs. (76) and (77) should reduce to the simpler forms obtained for this case. Eq. (76), becomes (if we put $C_1=L_2=0$)

$$\omega L_1 - \frac{1}{\omega C_2} + \frac{R}{R_p} \omega (L_1 + \mu_0 M) = 0,$$

which we previously obtained, and if $\frac{R}{R_p}$ is small enough to be negligible,

$$\omega = \sqrt{\frac{1}{L_1 C_2}},$$

and if this value of ω is substituted in Eq. (77), in addition to the condition that $C_1=L_2=0$, we find as the condition for oscillation,

$$R + \frac{1}{R_p C_2} (L_1 + \mu_0 M) = 0,$$

which we have already obtained from the circuit of Fig. 109.

In case $M=0$ and $L_2=0$, Eq. (76) becomes,

$$\left(\omega L_1 - \frac{1}{\omega C_2} \right) - \frac{L_1}{C_2} \frac{1}{\omega L_3 - \frac{1}{\omega C_1}} + \frac{R}{R_p} \left(\omega L_1 + \frac{\omega^2 \mu_0 L_3 L_1}{\omega L_3 - \frac{1}{\omega C_1}} \right) = 0,$$

and if again $\frac{R}{R_p}$ is negligibly small, we find,

$$\frac{1}{\omega L_1} - \omega C_2 + \frac{1}{\omega L_3 - \frac{1}{\omega C_1}} = 0. \dots \dots (78)$$

This is evidently the condition for zero reactive current in the three-branched plate circuit, one branch having L_1 , another having C_2 , and the third having L_3 and C_1 in series. Eq. (78) may be put into the form

$$\frac{1}{\omega^4} - [L_1 C_2 + (L_3 + L_1) C_1] \frac{1}{\omega^2} + L_1 C_2 L_3 C_1 = 0. \dots \dots (79)$$

If we put $[L_1 C_2 + (L_3 + L_1) C_1] = a$, and $L_1 C_2 L_3 C_1 = b$ we can write the two positive roots of this equation,

$$\frac{1}{\omega} = \sqrt{\frac{a}{2} \pm \sqrt{\frac{a^2}{4} - b}}.$$

Of these two roots for ω one is greater than $\sqrt{\frac{1}{L_3 C_1}}$ and the other is less than $\sqrt{\frac{1}{L_3 C_1}}$. We shall show that the only possible oscillation is the lower one of the two.

If we substitute $M=0$ and $L_2=0$ in Eq. (77), we find that the critical conditions for maintaining oscillations as given by,

$$R + \frac{L_1}{R_p C_2 \left(1 + \frac{\omega L_1}{\omega L_3 - \frac{1}{\omega C_1}}\right)} \left(1 + \frac{\omega \mu_0 L_3}{\omega L_3 - \frac{1}{\omega C_1}}\right) = 0, \dots \quad (80)$$

the condition for oscillation making the left-hand member less than zero.

The condition for oscillations is then determined by the inequality

$$\frac{\omega L_1}{\omega L_3 - \frac{1}{\omega C_1}} (R R_p C_2 + \mu_0 L_3) + L_1 + R R_p C_2 < 0. \dots \quad (81)$$

This can evidently be satisfied only by having

$$\omega L_3 - \frac{1}{\omega C_1} < 0, \dots \quad (82)$$

which shows that the circuit cannot sustain oscillations at a frequency which makes ωL_3 greater than $\frac{1}{\omega C_1}$. This bears out the prediction made above that of the two roots of Eq. (79), only that one having a value less than $\sqrt{\frac{1}{L_3 C_1}}$ is a possible frequency for the oscillations because the conditional inequality (82) may be written,

$$\omega < \sqrt{\frac{1}{L_3 C_1}}. \dots \quad (83)$$

Eq. (81) also serves to further limit C_1 , because from it we get the relation,

$$C_1 > \frac{1}{\omega^2} \frac{L_1 + R_p R C_2}{L_1 L_3 (\mu_0 + 1) + R_p R C_2 (L_1 + L_3)}. \dots \quad (84)$$

So we have C_1 fixed by the double condition,

$$\frac{1}{\omega^2 L_3} > C_1 > \frac{1}{\omega^2} \frac{L_1 + R_p R C_2}{L_1 L_3 (\mu_0 + 1) + R_p R C_2 (L_1 + L_3)}.$$

The relation given in (84) shows that if $\mu_0 L_3 > L_1$ (which will generally be the case), $\frac{\delta C_1}{\delta R}$ is positive, so that as the resistance of the oscillating

circuit is increased, the value of C_1 must also be increased to maintain the oscillations. By similar reasoning, we see that C_1 must be increased as the frequency of the oscillations is diminished.

If we consider both magnetic and static coupling as given in Fig. 120, we can much simplify the general equations obtained—(76) and (77)—by supposing L_2 absent and $\frac{R}{R_p}$ negligibly small. Eq. (76) then becomes,

$$\omega L_1 - \frac{1}{\omega C_2} + \left(\omega M - \frac{1}{\omega C_2} \right) \frac{\omega(L_1 - M)}{\omega(L_3 - M) - \frac{1}{\omega C_1}} = 0, \dots \quad (85)$$

and Eq. (77) becomes,

$$R + \frac{(\mu_0 + 1)\omega(L_1 L_3 - M^2) - \frac{L_1 + \mu_0 M}{\omega C_2}}{R_p C_2 \left\{ \omega(L_1 + L_3 - 2M) - \frac{1}{\omega C_2} \right\}} = 0. \dots \quad (86)$$

The capacity coupling serves to increase the magnetic coupling if M is negative and if $\omega(L_3 - M) - \frac{1}{\omega C_1} < 0$. Even if M is positive the con-

dition for oscillations may be still maintained by using sufficient capacity coupling.

It is to be noted that even if no actual condenser C_1 is used in the circuit, there is always such a capacity present in the tube itself, due to capacity between the actual grid and plate, as well as that of the lead-in wires connecting to them. At very high frequencies this internal tube capacity may very seriously affect the behavior of the tube; in certain tubes of foreign manufacture the lead-in wires of the plate and grid are kept as far from each other as the structure of the tube permits with the idea of minimizing this internal capacity. (See tube (O) of Fig. 21, page 389.)

Another circuit which may be used is shown in Fig. 122. For this case, we have,

$$e_p = -L_1 \frac{di_1}{dt} - M \frac{di_2}{dt}$$

$$e_g = -L_2 \frac{di_2}{dt} - M \frac{di_1}{dt}$$

and as

$$R_p i_p = e_p + \mu_0 e_g,$$

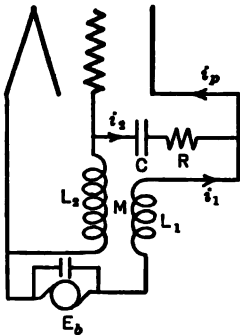

FIG. 122.—This circuit is similar to that of Fig. 120, but simplified by eliminating the dummy antenna circuit.

we have the relation

$$R_p(i_1 + i_2) + (L_1 + \mu_0 M) \frac{di_1}{dt} + (\mu_0 L_2 + M) \frac{di_2}{dt} = 0. \quad (87)$$

When the reactance across the machine or battery furnishing the plate voltage is negligible (it should always be made so by shunting with a large capacity, if necessary), we have

$$-L \frac{di_1}{dt} - M \frac{di_2}{dt} = -L_2 \frac{di_2}{dt} - M \frac{di_1}{dt} - Ri_2 + e_C, \quad (88)$$

and as

$$i_2 = -C \frac{de_C}{dt},$$

we can write (88) in the form,

$$(L_1 - M) \frac{d^2 i_1}{dt^2} = (L_2 - M) \frac{d^2 i_2}{dt^2} + R \frac{di_2}{dt} + \frac{i_2}{C}. \quad (89)$$

From this i_1 might be eliminated and so enable a solution of i_2 to be obtained. Instead of this formal procedure, we guess at the solution and put,

$$i_1 = I_1 \sin \omega t \text{ and } i_2 = I_2 \sin (\omega t + \phi).$$

Using these two values and substituting in Eq. (89), we get,

$$\omega^2 \frac{R}{R_p} (\mu_0 L_2 + M)(L_1 - M) - \omega(L_1 - M) \left[\omega(L_2 - M) - \frac{1}{\omega C} \right] - R^2 - \left[\omega(L_2 - M) - \frac{1}{\omega C} \right]^2 = 0, \quad (90)$$

and

$$R_p R (L_1 - M) + \omega(L_1 - M)(\mu_0 L_2 + M) \left[\omega(L_2 - M) - \frac{1}{\omega C} \right] + (L_1 + \mu_0 M) \left[R^2 + \left(\omega(L_2 - M) - \frac{1}{\omega C} \right)^2 \right] = 0. \quad (91)$$

If in (90) we neglect the terms $\frac{R}{R_p}$ and R^2 , we get for the natural period of the circuit,

$$\omega = \frac{1}{\sqrt{(L_1 + L_2 - 2M)C}}. \quad (92)$$

And using this value of ω in Eq. (91), which determines the critical condition for oscillation,

$$R[R_p(L_1 - M) + R(L_1 + \mu_0 M)] < \frac{[\mu_0 L_2 - L_1 - (\mu_0 - 1)M](L_1 - M)^2}{(L_1 + L_2 - 2M)C}. \quad (93)$$

This conditional inequality requires,

$$\mu_0 L_2 > L_1 + (\mu_0 - 1)M.$$

If we suppose there is no magnetic coupling $M=0$ and the frequency of oscillation becomes,

$$\omega = \frac{1}{\sqrt{(L_1+L_2)C}}, \dots \dots \dots (94)$$

and the condition for oscillation

$$R(R_p+R) < \frac{L_1(\mu_0 L_2 - L_1)}{(L_1+L_2)C} \dots \dots \dots (95)$$

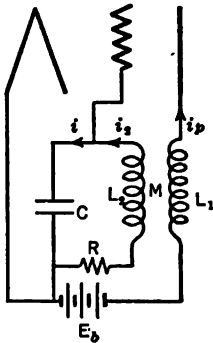

FIG. 123.—This is the circuit generally used when an oscillating tube is used to receive a continuous-wave signal; the oscillatory circuit is here associated with the grid.

Oscillating Circuit in the Grid Circuit.—When a three-electrode tube is used as detector for continuous waves, it is necessary to have an additional tube for producing the local oscillations or else to use the detecting tube itself to generate the local oscillations. While any arrangement which makes the tube oscillate will serve for the purpose, the one which is probably used more frequently than any other is shown in Fig. 123; the tuned circuit is now associated with the grid, being coupled to the plate circuit by a coil in the plate circuit, L_1 . This coil is generally called the “tickler” coil.

If we make the same assumption as has been made for all the other circuits so far considered namely, the grid takes no current, then $i_2 = i$ and the equations of the circuits are,

$$e_p = -M \frac{di_2}{dt} - L_1 \frac{di_p}{dt},$$

and

$$e_g = -L_2 \frac{di_2}{dt} - Ri_2 - M \frac{di_p}{dt}.$$

Also

$$R_p i_p = e_p + \mu_0 e_g = -(M + \mu_0 L_2) \frac{di_2}{dt} - \mu_0 R i_2 - (L_1 + \mu_0 M) \frac{di_p}{dt}$$

or

$$R_p i_p + \mu_0 R i_2 + (\mu_0 L_2 + M) \frac{di_2}{dt} + (L_1 + \mu_0 M) \frac{di_p}{dt} = 0. \dots \dots (96)$$

Now

$$-L_2 \frac{di_2}{dt} - M \frac{di_p}{dt} - Ri_2 = e_c \text{ and } i = -C \frac{de_c}{dt}.$$

By deriving above equation and substituting value of i , then eliminating i_p between the resulting equation and Eq. (96) we get (substituting the symbol i for both i and i_2 , which are the same)

$$\frac{1}{R_p} (L_1 L_2 - M^2) \frac{d^3 i}{dt^3} + \left(L_2 + L_1 \frac{R}{R_p} \right) \frac{d^2 i}{dt^2} + \frac{(R + L_1 + \mu_0 M)}{C R_p} \frac{di}{dt} + \frac{i}{C} = 0. \dots (97)$$

Guessing the solution to be $i = I \sin \omega t$ substituting the proper derivatives in Eq. (97), we get for the period of oscillation,

$$\omega = \frac{1}{\sqrt{C\left(L_2 + L_1 \frac{R}{R_p}\right)}}, \dots \dots \dots (98)$$

which is practically the same as $\frac{1}{\sqrt{CL_2}}$

For the limiting condition of oscillations, we find,

$$R + \frac{1}{R_p C} \left(L_1 + \mu_0 M - \frac{L_1 L_2 - M^2}{L_2 + L_1 \frac{R}{R_p}} \right) = 0. \dots \dots (99)$$

Eq. (99) can be written in the form,

$$R + \frac{1}{C\left(L_2 + L_1 \frac{R}{R_p}\right)} \left\{ \frac{1}{R_p} \left[\left(L_2 + L_1 \frac{R}{R_p} \right) (L_1 + \mu_0 M) - L_1 L_2 + M^2 \right] \right\} = 0,$$

from which, using (98) and neglecting terms involving $\frac{R}{R_p}$, we get,

$$R + \frac{\omega^2 M (\mu_0 L_2 + M)}{R_p} = 0, \dots \dots \dots (100)$$

and this can be satisfied only if M is negative and its absolute value is greater than $\mu_0 L_2$. The condition imposed by (100) will be satisfied if M is negative and its absolute value lies between the two roots of Eq. (100). So the absolute value of M is limited by the relation,

$$\frac{\mu_0 L_2}{2} - \sqrt{\left(\frac{\mu_0 L_2}{2}\right)^2 - \frac{R R_p}{\omega^2}} < M < \frac{\mu_0 L_2}{2} + \sqrt{\left(\frac{\mu_0 L_2}{2}\right)^2 - \frac{R R_p}{\omega^2}}. (101)$$

The condition is evidently different from that existing when the oscillating circuit was in series with the plate. In that case if M exceeded its critical value the value of the oscillating current was reduced, but there was no upper limit for the permissible value of M . With the oscillating circuit in series with the grid, however, the oscillations will cease if the absolute value of M exceeds a certain critical value.

Circuits of Very High Frequency.¹—Vacuum-tube circuits will generate any frequency between one per second or less to many millions per second; the low frequencies require very high values of L and C , but

¹ Many other circuits than the few here analyzed have been designed and used. The reader is referred to an article by L. A. Hazeltine in Proc. I.R.E., April, 1918, one by W. C. White in G. E. Review for September, 1916, and one by G. C. Southworth in the Radio Review for September, 1920. Southworth has been able to obtain frequencies as high as 3×10^8 cycles per second.

are comparatively easy to produce. To get the very high frequencies, it is necessary to consider carefully all the capacity in the circuit, especially that in the tube.

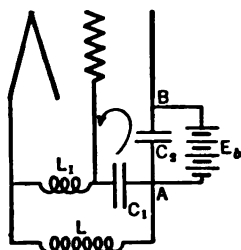

Fig. 124.—A circuit used for generating very high frequency; the oscillatory circuit is indicated by the arrow.

The circuit shown in Fig. 124 will generate perhaps as high as 10^8 cycles per second, if the internal capacity of the tube is low. The oscillating circuit is indicated by the arrow, and must be made with very short leads; the condensers C_1 and C_2 should each be several milli-microfarads, and the values of L_1 and L have to be properly selected for maximum oscillating current.

These very high-frequency currents often occur when neither expected nor wanted. Thus in the connection scheme shown in Fig. 125, the circuit in which oscillations are desired is made up of L_g ,

R , and C , the current being indicated by ammeter A_1 . If C is too large, the conditions for oscillations in the main oscillatory circuit may not be satisfied, but the adjustment may serve to maintain oscillations in the circuit indicated by the arrow. That the tube is oscillating is known by indication of the continuous-current ammeter in the plate circuit, but ammeter A_1 shows nothing. If, however, a hot-wire meter of low resistance be inserted in the grid lead, as shown at A_2 , it will be found that a comparatively large current is being generated in the local path.

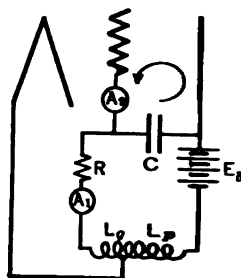

Fig. 125.—In a circuit such as this the oscillatory circuit is made up of R , L_g , L_p , and C in series; the circuit is very likely, however, to set up spurious high-frequency oscillations in the circuit including grid, plate, and C as indicated by the arrow.

A similar condition may occur in the circuit of Fig. 126; the main oscillating circuit $L-C$ may show no current at all, but oscillations of very high frequency may be flowing through L_g and L_p as indicated by the arrow, the dotted condenser really being the internal capacity of the tube.¹

Elimination of Undesired Frequencies.—These undesired high-frequency currents are sometimes troublesome, but may, in general, be eliminated by suitable precautions. Thus in a circuit used with a Type *P* pliotron the arrangement of apparatus was nearly as shown in Fig. 122; in series with R and C was another inductance, the

¹ The circuit shown in Fig. 126, without the main oscillating circuit, ($L-C-A$) is frequently used to produce oscillations of high frequency in a receiving set. The values of L_g and L_p must be adjustable for different frequencies. A very complete discussion of this circuit is given by A. S. Blatterman in Vol. 1, No. 13, of the *Radio Review*.

actual connection being as shown on the curve sheet given in Fig. 178, p. (570).

With L_p , of this figure, below a critical value, the main circuit, $L_g-L_p-C-L-R$, will not oscillate; it is quite likely, however, that when the main circuit is not oscillating, high-frequency currents will be generated in the circuit made up of L_g and L_p in series with the internal capacity of the tube. Thus, with $L_g=200 \mu h$, $L_p=400 \mu h$, $L=8000 \mu h$, $C=.002 \mu f$, the ammeter I (Fig. 178) gave no indication, but the meter I_p showed that the tube was oscillating violently. Test with wave-meter showed the circuit, L_g-L_p -tube-capacity, to be generating a complex current of fundamental wave-length equal to 800 meters; this is about the natural frequency of the circuit.

The desired wave-length, of about 6000 meters, was not started until L_p was adjusted in excess of $1200 \mu h$; the frequency changed suddenly from one value to the other, as L_p was varied through its critical value. There is a tendency in such a circuit, however, to maintain the existing oscillation; thus if L_p was increased, the high-frequency oscillation persisted until L_p exceeded $1200 \mu h$. As L_p was decreased, however, the high-frequency oscillation did not start until L_p was made less than $1000 \mu h$, so that with $L_p=1100 \mu h$, either 900 meter or 6000 meter oscillations might exist, depending upon whether L_p had been decreased from a high value to $1100 \mu h$, or had been brought up to the value from something lower.

An interesting condition was found in this test: if the condenser across machine E_b was taken out the high-frequency oscillations was very persistent, whereas the 6000-meter oscillation would not start, no matter what value L_p might have. Evidently for the lower frequency the machine offered a high-inductive reactance and resistance, whereas for the high-frequency current it acted like a condenser of low impedance.

The undesired high-frequency current for the circuit above described was completely eliminated by introducing a suitable resistance directly in series with the grid, as indicated at A in Fig. 178; 100 ohms sufficed to diminish their amplitude considerably and 2000 ohms at this point resulted in such high losses for the 800-meter wave that it could not sustain itself. This high resistance had a negligible effect on the 6000-meter oscillation, because of the comparatively small charging current flowing to the grid at this frequency.

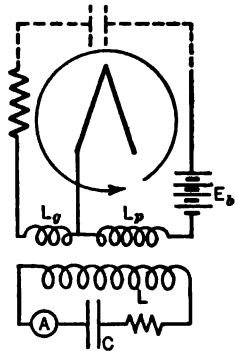

FIG. 126.—In a circuit of this kind (often called a Meissner circuit) spurious oscillations may be set up in the circuit indicated by the arrow, the main oscillatory circuit remaining unexcited.

Constancy of Frequency of an Oscillating Tube.—The foregoing formulæ for frequency of oscillation of a tube circuit have all been derived on the assumption that the grid current was zero, and do not involve any characteristics of the tube, except μ_0 and R_p . It is a fact, however, that there is an appreciable capacity between the grid and filament of a tube, and that the value of this capacity varies with any factor which affects the μ (not μ_0)¹ of the tube and circuit, as shown on page 432 et seq. This grid-filament capacity is always shunted across a part of the oscillating circuit and so must have an effect on the frequency of oscillation of the circuit.

It is therefore evident that any factor which influences either tube resistance or grid-filament capacity must also effect, to some extent, the frequency of oscillation, and such is found to be the case. A change in either of the filament current or plate voltage will produce variations in frequency the variation, sometimes amounting to 1 per cent or 2 per cent, without excessive change in either I_f or E_b .

The Oscillating Tube as Detector of Continuous Waves—Autodyne.—The circuit given in Fig. 123 is generally used for exciting a tube used as autodyne receiver; with no grid condenser, as shown in Fig. 127, the detecting efficiency of the tube is indicated by Eq. (31). The antenna circuit L_3C_a is tuned to incoming signals and the circuit

L_2C is tuned to a frequency differing from this signal frequency by about 800 cycles per second, so as to give a beat note for which both the ear and ordinary telephone receiver are sensitive.

From Eq. (31) it seems that the more violently the tube is oscillating, thereby making E'_g as large as possible, the more sensitive will the tube act as detector, and so it does as long as $\frac{d^2i_p}{de_g^2}$ remains constant. This

term $\frac{d^2i_p}{de_g^2}$ is really a measure of the assymetry of the change in plate current when E_g is positive and when it is negative; in other words, it measures

¹ Changing the plate-circuit impedance changes the effective value of the tube capacity (and hence its effect on the frequency of oscillation), because the μ of the tube and circuit has been changed; the μ_0 of the tube, however, has not been altered by changing the plate-circuit impedance.

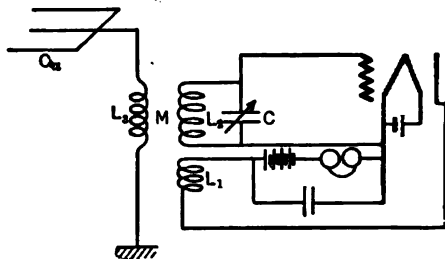

Fig. 127.—This is the arrangement generally used when an oscillating tube is to act as detector for continuous-wave signals. The frequency of the local oscillations is fixed by the values of L_1 and C , the tickler coil, L , serving to make the tube oscillate.

the excess of the increase of plate current for positive E_p , over the decrease for negative E_p . So long as the relation between I_p and E_p is parabolic the value of $\frac{di_p^2}{de_p^2}$ is constant, but for this condition the tube resistance R_p is also constant. We have previously shown, however, that to make a tube oscillate, the coupling (of whatever kind is used) must be increased beyond a certain critical value, and that after this value is past the oscillations start and automatically increase in amplitude, until the plate resistance R_p is sufficiently increased to restore a certain balance which was destroyed by increasing M . This change of resistance was analyzed in discussing Fig. 114. The plate current in an autodyne receiver will fluctuate over the straight part of the full-line curve of this figure if the value of M (between L_1 and L_2 of Fig. 127) is kept sufficiently low: if it is increased much beyond its critical value the fluctuation in plate current will extend over the upper and lower bends of the curves.

The tube will act best as a detector of continuous-wave signals for that coupling of L_1 and L_2 (Fig. 127) which results in the greatest product of $E'_p \frac{d^2 i_p}{de_p^2}$. This product will generally be a maximum for the weakest coupling which will maintain the tube in the oscillating state; such is nearly always found to be the case in practice. If the coupling between L_2 and L_3 is held constant and the coupling between L_2 and L_1 is diminished, the signal strength will be a maximum for the weakest possible coupling. In carrying out this test it is necessary continually to change C to keep the beat note of constant pitch, because of the effect of L_1 on the value of the effective self-induction of L_2 .

Three possible conditions of the adjustment of a beat receiver are shown in Fig. 128. In (a) the coupling is so adjusted (tight) that the grid potential, with no incoming signal, fluctuates between A and B ; the plate current fluctuates with a frequency nearly the same as that of the signal, between the values AG and BH , its average value being OI . This current OI flows through the phones and the high-frequency alternating component of the plate current is carried by the condenser shunting the phones. In case no actual condenser is used to shunt the phones this current will utilize the capacity of the phone cords or the distributed capacity of the windings to by-pass the high inductance circuit of the windings themselves.

When the signal voltage E_p is superimposed on the grid it alternately increases and decreases the amplitude of the grid fluctuations of potential; the value of grid potential now fluctuates with variable amplitude, the amplitude being fixed by the limiting values EF and DC , the frequency of these cycles of variation of amplitude being equal to the difference in frequency of E_p and E'_p .

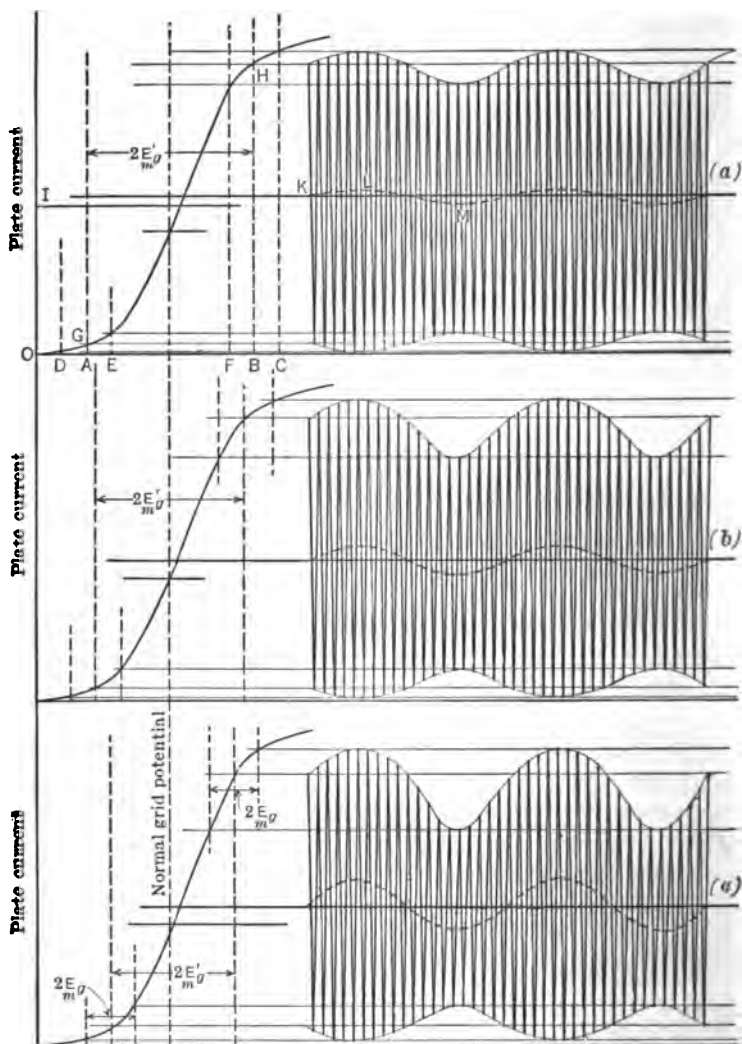

FIG. 128.—This diagram shows the effect of the strength of the local oscillations on the signal strength; the audio frequency current through the phones, which gives the audible signal, is indicated by the wavy dashed line in each diagram. In (a) the local oscillations are too violent to give a good signal, in (b) the signal is somewhat improved and in (c) it is best. It is doubtful if the local oscillation could be cut down as much as indicated in (c) without stopping the oscillations altogether. For all three diagrams the amplitude of the high-frequency signal voltage is the same.

The plate current will now be of the form shown in the right-hand part of the diagram, and the average value of this high-frequency plate current will be as shown by the dashed line shown at *K*, *L*, *M*, etc., and it is this pulsating current which, flowing through the telephone receivers, gives the signal.

In diagram (b) of Fig. 128 is shown the effect on the signal strength of reducing somewhat the amplitude of the locally generated oscillations E'_o , which occurs as a result of decreasing the coupling between L_1 and L_2 in Fig. 127 (dotted line of Fig. 112). Although E'_o is less than in diagram (a), the value of the signal current (shown again by the dashed line) is greater for (b) than it is for (a).

In diagram (c) of Fig. 128 is shown the result of still further decreasing the value of the local oscillation E'_o ; it is likely that *M* could not be suf-

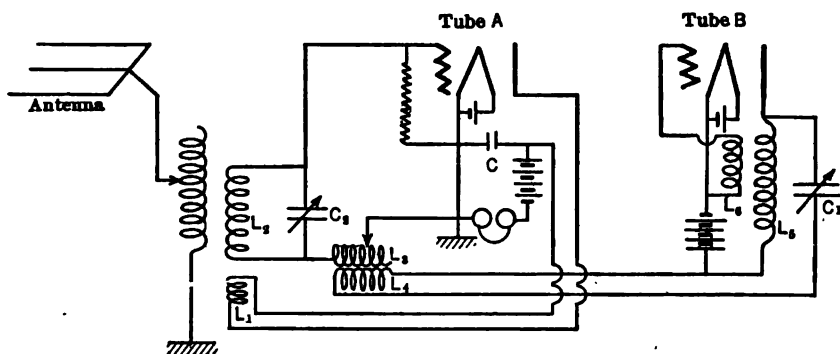

FIG. 129.—In order to control easily the strength of the local oscillations impressed on the detecting tube it is best to have a separate oscillator and couple this properly to the detector, Tube A. In this diagram Tube B is the oscillator; it is coupled to the detector by the two coils L_5 and L_2 .

ficiently reduced to make the tube oscillate in this fashion without stopping the oscillations altogether. The signal current is, however, greater for this condition than for either of the two other values of E'_o , shown at (a) and (b).

Use of a Separate Tube for Generating the Local Oscillations.—In order to use the vacuum tube as detector most efficiently it is necessary to have the amplitude of the voltage E'_o under control, and this can best be done by using a separate tube for generating the voltage E'_o , in addition to the detecting tube. The scheme of connection is then as shown in Fig. 129. The local oscillations are generated in tube B, their frequency being fixed approximately by L_4 , L_5 , and C_1 , and intensity by the coupling between L_5 and L_2 . This coupling should be considerably greater than the critical value, so that as conditions in the circuit are changed the oscillations of tube B are not stopped.

The value of E' , impressed on the grid of the detecting tube A can be controlled by varying the mutual inductance between L_3 and L_4 , either by moving the coils with respect to one another or by changing the value of either of them. The value of M should be so adjusted that the condition obtained is that shown in Fig. 128, diagram (c).

The antenna circuit and L_2C_2 circuit are each tuned for the frequency of the incoming signal, and the coupling between L_1 and L_2 is adjusted as near the critical value as possible. We have shown that the effect of the coupling between L_2 and L_1 is to decrease the resistance of the L_2C_2 circuit, and this resistance may be made to approach zero, if the coupling is suitably adjusted. Further, the L_2C_2 circuit can be exactly tuned for the incoming signal, so that the reactance is zero also, hence

*the impedance of the L_2C_2 circuit may be made to approach very close to zero, so that the current caused to flow by a weak signal may be perhaps a hundred or more times greater than it would be if the coupling L_1-L_2 were not used.*¹

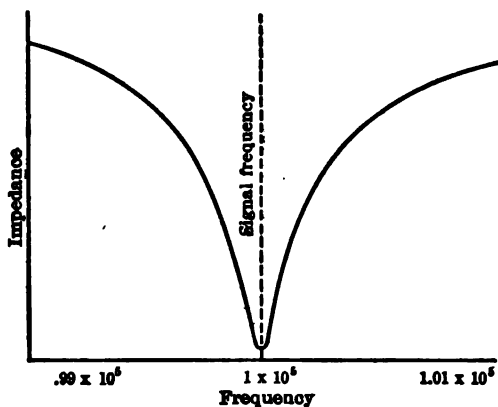

FIG. 130.—By properly adjusting the coupling of coils L_1 and L_2 of Fig. 129 (keeping the coupling too low to produce oscillations in L_2-C_2) the resistance of the circuit L_2-C_2 may be made to approach zero. This curve shows how the impedance of the L_2-C_2 circuit will then vary with frequency of impressed signal.

The impedance of the L_2C_2 circuit, as a function of the impressed frequency, has the form shown in Fig. 130; it is evident from this curve that not only is the circuit of Fig. 129 one to amplify signal strength, but also that this amplification is very selective. With a low resistance coil for L_2 and

a well-insulated condenser, and the grid circuit of the tube adjusted to absorb but little power, the selectivity is extremely sharp.

Effect of Condenser in Series with the Grid on the Critical Coupling.—

In the foregoing analyses of the conditions required for self-excitation of tubes no mention was made of the effect of a condenser in series with the grid, as affecting the possibility of oscillation. In some common oscillating circuits it is necessary to use a grid condenser to insulate the grid from a high positive potential; such a one is shown in Fig. 131.

¹ An experimental investigation of the magnification obtainable in such circuits was carried out by E. H. Armstrong and reported in Proc. I.R.E., Vol. 5, No. 2, April, 1917

The oscillating circuit is made up of L with C_1 and C_2 in series, and the tube is connected to it as shown. The excitation for the grid is supplied by the drop of potential between the points $A-C$ and the plate voltage is fixed by the drop across condenser C_2 . The scheme of connection results in the coil L being at plate potential, i.e., it is positive with respect to the filament by an amount equal to E_b ; if the grid were connected directly to point C , the tube would at once burn out, due to excessive plate and grid currents.

The grid is therefore insulated (in so far as continuous voltage is concerned) by the condenser C_3 ; a suitable leak resistance R serves to hold the grid at a proper average potential. The excitation impressed on the grid is now not equal to the potential drop between points $A-C$, but somewhat less than this due to the drop across the condenser C_3 ; moreover, due to the absence of the leak path across C_3 and the presence of such a leak across the grid-filament circuit, the phase of the voltage impressed on the grid is not the same as that of the voltage across condenser C_1 .

The effect of the drop across C_3 is to require a higher drop across $A-C$ than would otherwise be required; if it should happen that the capacity of C_3 is equal to the capacity of the input circuit of the tube, then C_1 must be made only one-half as large as it would otherwise have to be.

Effect of Oscillations on the Magnitude of the Plate Current.—If an oscillatory circuit has a condenser in series with the grid, the average value of the plate current will always decrease when oscillations begin; this is due to accumulation of electrons on the grid forcing its average potential more negative when oscillations start, causing an accompanying decrease in the plate current. This effect is shown by the decrease in the reading of a continuous-current meter in series with the plate.

When the oscillating circuit is such that no grid condenser is required, and none is used, the reading of the continuous current meter in the plate circuit will generally increase when oscillations start, the increase being more the greater the excitation of the grid. This statement is not universally true; it is possible to so adjust the conditions that when oscillations start the average value of the plate current stays the same, or even decreases. This effect can be noted if, with all other conditions constant,

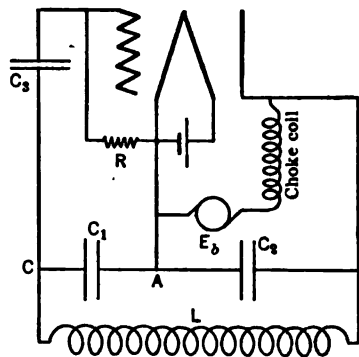

FIG. 131.—In a circuit of this kind it is necessary to use a condenser C_3 to insulate the grid from the high continuous voltage impressed on coil L by machine E_b .

the filament current is varied throughout a sufficient range of values; with high filament current, the plate current will increase when oscillations start, and with low filament current it will decrease. The case is similar to the action of the tube as a detector, without grid condenser as described in p. 444; it is there shown that the effect of an incoming signal may be to either increase or decrease the average value of the plate current.

Criteria of the Oscillating Condition of a Detecting Tube.—In the case of a power tube the oscillatory condition is indicated by the meters used either in the grid circuit, plate circuit, or oscillating circuit. In the case of a small tube used for the detection of continuous-wave signals there are generally no meters in the circuit to indicate oscillations; it is, however, extremely important that the operator should know at all times whether or not his tube circuit is oscillating, because if it is not oscillating he cannot possibly hear the signal for which he is listening. The only method of testing for oscillations in the ordinary continuous-wave detecting set is to properly interpret the noises in the telephone receivers; to an experienced operator they serve as well as do the meters on a power set.

When no condenser is used in series with the grid it is very easy to tell when the tube is oscillating and when not; when grid condenser is used the determination is not so easy. There are two methods of testing for oscillations; *first*, by making the coupling of the tickler coil (or other type of coupling) so weak that the circuit is not generating oscillations and then gradually increasing the coupling past the critical value, listening for the characteristic noise which occurs when the critical coupling is exceeded and, *second*, by properly interpreting the noises heard in the receivers when the grid terminal is grounded by putting the thumb or one finger, on the negative end of the filament circuit and touching the grid terminal with another finger. These two schemes may be called the *coupling test* and *finger test*.

As has been noted above when a tube circuit starts to oscillate the plate current practically always changes its average value, generally increasing when no grid condenser is used. The change in the plate current is not extremely rapid because, with the critical value of coupling, it takes many cycles before the steady state is reached; the result of the slow change in plate current is to produce a peculiarly soft quality of click in the receiver.¹ This noise resembles, perhaps more than anything else, the "plucking" of a loose violin string and, when once noted, is very easy to recognize.

In the case of no grid condenser this coupling test is very reliable

¹ When listening for this noise the coupling must not be increased too slowly; with a very slow increase in the coupling the noise is so soft that it may not be heard at all. When first listening for this noise the tickler coupling should be changed quite rapidly.

and easy to make. If grid condenser is used the distinctness of this plucking sound is by no means as pronounced as is the case for no grid condenser; for some values of capacity and leak resistance it is almost impossible to hear it at all, even though the critical coupling is known and especial care is used in listening.

In the case of no grid condenser the finger test gives very distinct indication of the oscillating condition; with the moistened thumb placed on a filament connection (binding post) a finger is touched to the grid connection of the tube, thus grounding the grid to an extent sufficient to stop oscillations.² The cessation of oscillations is accompanied by a sharp click in the receivers and when the finger is removed from the grid connection the starting of oscillations, with accompanying change in plate current, is indicated by another click, generally less distinct than the first. For coupling of the tickler coil considerably in excess of the critical value, the two clicks (starting and stopping oscillations) are of about the same intensity.

With grid condenser and leak the finger test does not give reliable results, except to the experienced operator; even with no oscillations two clicks are heard when the finger is touched to the grid connection and when it is removed therefrom. With the tube not oscillating the grid is practically always positive, with respect to the potential of the negative end of the filament; when the grid is grounded by the finger, thus suddenly bringing it to the same potential as the filament, a sudden change occurs in the plate current with resultant click in the receiver; when the finger is removed the grid at once resumes its normal positive potential and so again gives a change in plate current and click in the phones. As has been previously noted, when grid condenser is used the grid leak resistance is best connected by the positive end of the filament; such has been assumed in statements just made.

The same two clicks are observed if the tube is oscillating, and there is not much difference between the clicks in the two cases. This is especially true if the grid condenser is small and electron supply in the vicinity of the grid plentiful; if, for example, with an ordinary detecting tube the grid condenser is $100 \mu\mu f$ (a commonly used value) and filament temperature normal, even a good operator may not distinguish any difference in the clicks for the oscillatory and non-oscillatory condition.

If, however, the grid condenser is much larger, say $5000 \mu\mu f$ or larger, there is a marked difference to be noticed; with oscillations the two clicks have nearly the same intensity, but with no oscillations the click heard upon removing the finger from the grid connection is much softer than

² On most receiving sets it will be found that, even though the grid connection directly at the tube is not accessible, some screw or binding post connected to the grid, is available.

the one heard when making contact with the grid. When the tube is not oscillating it takes an appreciable time to charge the grid condenser to its normal potential and the accompanying change in plate current is slow, thus giving a weak sound; the larger the grid condenser and the lower the filament temperature, the longer will this charging time be and correspondingly weaker is the click in the receivers.

The tests for the oscillating condition can then be summarized as follows:

Coupling Test.—*No Grid Condenser.*—Distinct sound (plucking string) when critical coupling is exceeded.

With Grid Condenser.—The click occurring when critical coupling is exceeded is not distinct unless the grid condenser is large (several millimicrofarads) and the filament temperature subnormal.

Finger Test.—*No Grid Condenser.*—Two distinct clicks when tube is oscillating and none at all when tube is not oscillating.

With Grid Condenser.—Two distinct clicks of nearly equal intensity if tube is oscillating; if tube is not oscillating the click upon touching the grid connection is more pronounced than that when releasing the grid, the distinction being more pronounced with larger grid condensers.

Peculiarities of Adjustment of Oscillating Detectors.—When first working with oscillating detectors certain apparent discrepancies will be encountered. Thus if the tuned grid circuit uses one of the coils of a loose coupler and the other coil of the coupler, or a section of it, is used for the tickler coil, it may be found that when the coils are separated, oscillations occur, *no matter which way the tickler coil is connected in the plate circuit.* It may also be found that oscillations occur when the coils are quite widely separated and that as the coils are brought nearer together the oscillations cease, an apparent contradiction to the analysis previously given.

With the coils arranged as shown in Fig. 132, it is apparent that the magnetic coupling of L_1 and L_2 is weak, but it may well be that the two

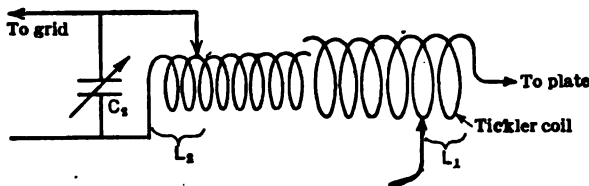

FIG. 132.—If an ordinary coupler is used in making tests for oscillations some peculiar results may be obtained.

coils of the coupler permit enough electrostatic coupling of the plate and grid circuits to produce oscillations, and this even if the connection of L_1 is reversed. Now if the

sense of the magnetic coupling of L_1 and L_2 is incorrect for producing oscillations, the electrostatic coupling of the two circuits will be neutralized as the two coils are brought closer together, and when they get close enough, the coupling due to both effects will be less than the

critical value and so oscillations will stop. In case the tickler coil consists of only a few concentrated turns this effect will not be noticed.

When the coupling of plate and grid circuits is accomplished by rotating one coil inside the other, it will often be found that setting the coils at right angles to one another, which of course makes $M=0$, will not stop oscillations and that the coils must be rotated considerably past the 90° point before the oscillations stop. This is because of the electrostatic coupling introduced by the proximity of the two coils; enough reversed magnetic coupling must be introduced so that the total coupling, inductive plus capacitive, is less than the critical value for the circuit. This effect is mentioned, and analyzed on p. 504.

Peculiar Noises Occurring in an Oscillating Detector Circuit.—If the oscillating detector circuit has no condenser in series with the grid its behavior is very regular, but if a grid condenser is used all sorts of queer noises may be heard in the phones, unless the adjustment is carefully carried out. The noise may vary from a series of regular "clicks," separated from each other by several seconds, to a high shrill signal; on carrying out further adjustments, the note may become so high as to be inaudible, so that the operator has no convenient way of telling that the action of the tube is irregular and that readjustment is required.

The condition practically always occurs as a result of too tight coupling of the tickler coil, too high a resistance for the grid leak, or a combination of both. The noise is due to the starting and stopping of oscillations, the musical pitch having nothing to do with the frequency of oscillation, but being fixed by the rapidity with which one group of oscillations follows the next.

The oscillations start, thus charging the grid condenser and reducing the mean potential of the grid and so changing the R_p of the tube; but the condition for oscillation for the circuit given in Eq. (101) depends upon R_p , and it is evident from inspection of this equation that if R_p increases, the value of M required for oscillation is increased. In Fig. 133 is shown the relation between E_p and I_p , for two values of E_{og} ; the curve OA is for $E_{og}=0$, and the curve DB is for E_{og} at some negative value. The slope of this curve serves as a measure of R_p , the value of R_p being actually given by the cotangent of the slope, when the scales for E_p and I_p are

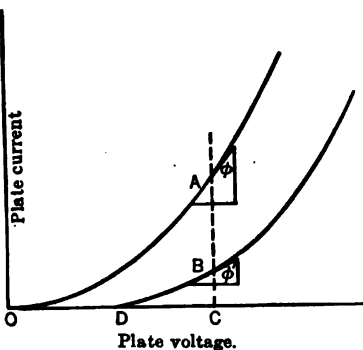

FIG. 133.—When oscillations start, in a circuit using a condenser in series with the grid, the plate-current curve may change from OA to DB , due to the decrease in average potential of the grid, when oscillations start.

the same; if not the same, the value of R_p obtained by measurement in the curve must be multiplied by the ratio of the "volts per inch" of this graph to the "amperes per inch."

Let us suppose that when oscillations start the normal potential of the grid is zero, the plate voltage being given by OC , Fig. 133; the value of R_p is then $\tan \phi$, and M is adjusted to such a value that oscillations start. The grid is then forced negative so that the E_p-I_p curve changes from OA to DB , thus increasing the value of R_p to $\tan \phi'$, and so increasing the coupling requirement, as given by Eq. (101), that the value of M is not sufficient to maintain oscillations, the circuit then stops oscillating.

During the oscillations, however, the grid condenser has become charged, and before oscillations can again start the charge must leak off sufficiently to bring the plate current from CB to CA , Fig. 133. The time required is fixed by the magnitude of the charge on the condenser and the time constant of the grid-condenser, grid-leak circuit. The adjustment might be such, for example, that 90 per cent of the charge in the condenser must leak off before oscillations again start. If $(1 - e^{-\frac{t}{RC}})$ is to be 0.90, we must have $\frac{t}{RC} = 2.3$; if then $C = 500 \mu\mu f$ and $R = 2$ megohms, we have $\frac{t}{RC} = 2.3 \times 5 \times 10^{-10} \times 2 \times 10^6 = .0023$ second. The starting and stopping of oscillations in the circuit would then occur about 500 times a second and a musical note of 500 vibrations a second would be heard in the telephone receivers.

If the leak resistance is greater in value, or the condenser of greater capacity, the note will be of lower pitch, and it will be higher if either the leak resistance or capacity is decreased. When the terminals of the vacuum tube are well insulated from one another and no external grid leak resistance is used it is possible to so adjust a tube circuit that the interval between successive groups of oscillations is a minute or more, thus producing a series of clicks in the telephone receivers separated from each other by that interval of time.

The pitch of these disturbing noises may be practically always sent beyond the audible limit by lightly touching the grid connection and filament connection of the oscillating tube; if the finger and thumb making the connection are pressed down too tightly the leak resistance will be lowered to such an extent that the tube will stop oscillating altogether. The pitch of the note may be varied by changing either the plate voltage or filament current, both of these having influence on R_p and thus on the critical value of the coupling M ; they also effect to some extent the grid leak resistance.

The squealing noise will nearly always be produced if, after the proper value of M has been obtained for a certain setting of the tuning condenser C (Fig. 123) the capacity of this condenser is much decreased. Decreasing C increases ω and so, according to Eq. (101), makes a lower value of M permissible; with the ordinary detecting-tube circuit, having grid condenser, it is practically always necessary to use the lowest value of M compatible with the requirements of Eq. (101) if steady oscillations are to be produced. A value of M much greater than this will not only cut down the sensitiveness of the tube as a detector, but is always likely to produce noises.

Use of Regenerative Circuit for Spark Reception.—A tube circuit arranged with "tickler" or other form of coupling for the detection of continuous-wave signals is also adapted for the reception of spark, or damped-wave, signals; with the antenna circuit and the local circuit (L_2-C of Fig. 127) tuned accurately to the incoming signal the tickler coupling can be increased to a value slightly less than that required for producing oscillations. The increase in intensity of the signal by using a suitable value of coupling can be increased thousands of times over the value it would have if no tickler coupling were used.

It has been shown that the effect of the coupling is to reduce the resistance of the L_2-C circuit to a very low value (Fig. 130) so that a certain e.m.f. impressed on this circuit, from the antenna circuit, will produce a current perhaps 100 times as great as would normally be the case. The change in the plate current (which gives the signal in the phones) is proportional to the square of the voltage impressed on the grid, as given in Eq. (18), and so will increase greatly as the resistance of the L_2-C circuit is made to approach zero by suitable tickler coupling. If *e.g.*, the actual resistance of L_2-C is 10 ohms and by means of tickler coupling the effective resistance is reduced to 0.1 ohm, the current in L_2-C is increased 100 times, the voltage impressed on the grid is increased 100 times, and the signal current, ΔI_p , is increased 10^4 times.

The effect on the signal strength as the mutual inductance between L_1 and L_2 (Fig. 127) varies is shown in Fig. 134; as M is increased the signal intensity rapidly increases, retaining its normal musical quality, until such a coupling is reached, OA , that oscillations start. The resulting noise in the telephone when the tube is oscillating, is of "scratchy" quality being caused by a kind of beat phenomenon between continuous waves locally generated and the incoming damped waves; as the phase relations between the successive wave trains and the continuous oscillations of the tube are of haphazard values, and as the amplitude of the spark signals is variable throughout each wave-train, the resulting variation in amplitude of the plate current is of very irregular character, thus

producing the scratchy note for couplings indicated by the dotted line in Fig. 134.

Regenerative Circuit for Short-wave Spark Reception.—For short-wave reception, say less than 400 meters, probably the most satisfactory type of circuit is one which uses no other coupling between the grid and plate circuits than that due to the capacity coupling in the tube itself. In this scheme the "tickler" coil of Fig. 127 is replaced by a small variometer, not coupled to the L_2-C circuit at all; the required amount of inductance in this variometer varies with the wave-length, type of tube, etc., but is generally less than 1 millihenry. It is best to add in the L_2-C circuit another variometer about the same as that used in the plate circuit, thus making it possible to tune the closed circuit with very small value of C .

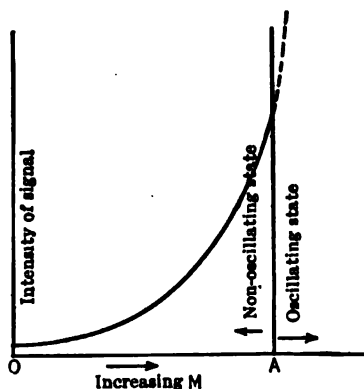

FIG. 134.—If the tickler coil is used when receiving spark signals (of sufficiently low decrement) the signal will increase very rapidly as tickler is increased until this passes its critical value; the tube starts to oscillate and then the signal, although very loud, loses its characteristic musical note and becomes "mushy" in quality.

The L_2-C circuit is carefully tuned to the incoming signal and the regenerative action is brought to its maximum permissible value by suitably adjusting the variometer in the plate circuit. As the plate inductance is increased, a slight further adjustment of the closed tuned circuit is generally required in order to get maximum sensitiveness.

Behavior of a Regenerative Receiver Regarding Sound of Signal, etc.—There are many interesting phenomena connected with the adjustments of this regenerative circuit other than those already mentioned. When M is made *just great enough* to produce oscillations (slightly greater than OA , Fig. 134) the detecting

efficiency of the circuit is greatly increased, so much so that spark signals so weak as to be entirely inaudible with tickler coupling just less than the critical value become quite loud when oscillations start. In this case the listening operator gets no clue to the identity of the sending station from the spark note because the signal is inaudible until the tube is oscillating, and then the distinctive spark note is not present.

If such a weak signal is coming in and the closed circuit is properly tuned to it (with tickler coupling about equal to its critical value), a peculiar effect is produced by the adjustment of the antenna circuit. With this circuit much detuned of course the signal is inaudible; as the antenna loading coil, or similar adjustment, is increased the signal becomes audible

with a scratchy quality (tube supposedly oscillating); as this adjustment is continued the signal increases in intensity until at a certain value of loading it disappears completely; on continuing the adjustment, however, the signal reappears at a certain point and gradually decreases as the adjustment is further carried out. Upon investigation it will be found that this narrow region where the signal is inaudible is caused by the *cessation of oscillations in the tube circuit*. The antenna circuit introduces a resistance effect into the oscillating tube circuit which varies with the relative tuning of the two, being a maximum when the antenna and closed circuit are tuned alike; hence a tickler coupling which is just sufficient to cause oscillations with an antenna somewhat mistuned is insufficient for the tuned condition. A quantitative idea of this change of resistance of the oscillating circuit, due to variation in antenna tuning is given in Fig. 91, Chapter I, p. 93.

For the best reception of the signal the adjustment of the antenna should be set at the midpoint of the silent region and the tickler coupling increased just sufficient to produce oscillations for the condition.

In case a continuous-wave signal is being received, the following effect of the antenna tuning on the reactance of the oscillating circuit may be noted. With antenna and closed circuit normally adjusted, a certain note is heard in the telephone; this note may be observed to vary over a considerable range as the tuning of the antenna is changed, the variation in note being caused by the change in the effective inductance in the closed oscillating circuit by the reaction of the antenna. The amount of change in note obtainable depends upon the coupling between antenna and closed circuit; some idea of its magnitude may be had by inspection of Fig. 91, Chapter I, p. 93.

Eqs. (84) and (85), p. 91, permit quantitative prediction of the amount of change in resistance and reactance of the oscillating circuit, as affected by the antenna circuit.

Operation of Power Tubes in Parallel for Greater Power Output.—Vacuum-tube generators or converters operate very well in parallel, remaining synchronized automatically;¹ the proper division of the load

¹ An interesting demonstration of the inherent tendency of tube circuits to synchronize with each other is easily obtained. If a small power tube is set into oscillation in the laboratory and an autodyne detector circuit in the same room is used for listening, it will be found that as the beat note is decreased from high value there will be a certain lowest audible note obtainable. Thus perhaps the detector adjustment is such as to give a beat note of 200; upon attempting to bring this detector more nearly into synchronism with the power tube, lowering the beat note, this note will completely disappear, and it will seem as though the autodyne had stopped oscillating, but it will be found that the beat note has disappeared because the detector tube has *pulled into synchronism* with the power tube. The closer the two circuits are together the higher will be the lowest beat note obtainable.

may be most easily accomplished by variation of the filament currents. All filaments may be lighted in parallel from the same source, but each filament should have its own rheostat; it is also best to have an ammeter in series with each plate and grid. A suitable connection scheme is shown in Fig. 135; the same scheme of connection can be used for any number of tubes.

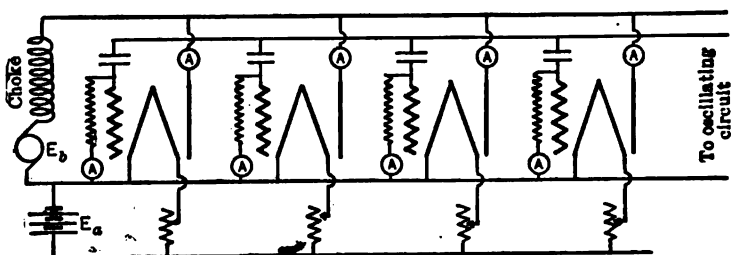

FIG. 135.—Connection of several power tubes for parallel operation.

The adjustments of the circuit must of course be changed as more tubes are put into operation, because the effective resistance of the load must equal the plate circuit resistance of the battery of tubes for maximum output, and the combined tube-circuit resistance varies inversely as the number in operation.

The voltage required for the filament of the ordinary power tube is about twenty; it is limited by the fact that too much power must not

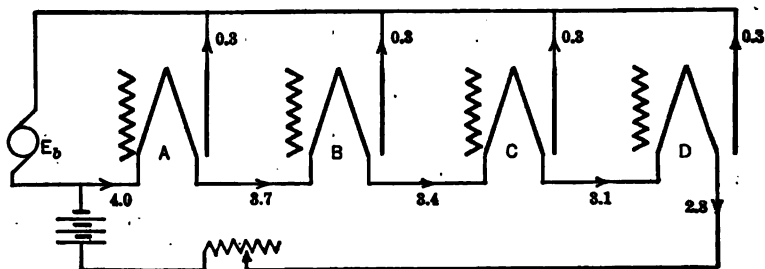

FIG. 136.—It is impossible to work tubes in parallel, with their filaments in series, because of the greatly different filament currents resulting in the different tubes.

be used in the filament circuit, yet the filament current must be fairly large because the plate current must not be more than about 15 per cent of the filament current, and this plate current must be a considerable fraction of an ampere unless excessively high voltages are used.

As the ordinary electrical power supply is 110 volts, it might seem that if tubes are to operate in a group several filaments might be connected in series, thus saving in power assumption; thus five 20-volt filaments might be operated on a 110-volt line and still leave enough volt-

scheme for using two kenotrons (rectifiers), *A* and *B*, connected to a high-voltage winding in such a way that the plate of the three-electrode generator *C* receives unidirectional pulses which serve in place of a continuous current supply. By the use of suitable condensers, *D*, and choke coils, *E*, the power supplied to the plate of *C* may be made as uniform (free from pulsation) as may be desired.

The four transformer coils shown, *F* the primary, *G* and *H* low-voltage secondaries and *I*, high-voltage secondary will all be wound on the same core; the low-voltage winding *H* must be protected from the other windings and core by high-voltage insulation because it assumes a high positive potential as soon as operation of the set begins. If the voltage desired in the plate of tube *C* is 2500 volts the winding *I* should have a voltage rating of 5000 or 6000 volts (effective).

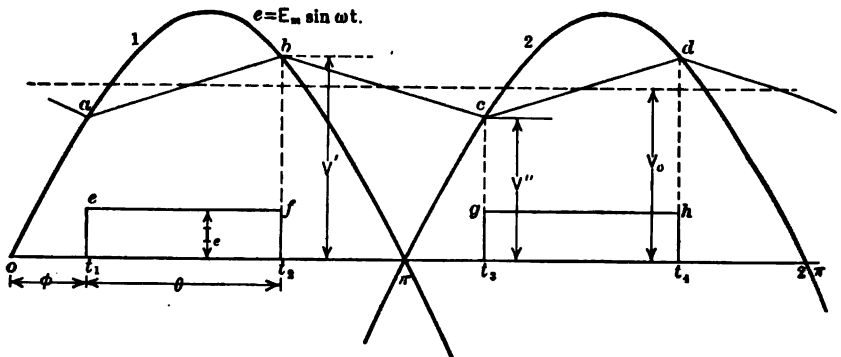

FIG. 139.—Illustrating the action of the rectifier tubes, in connection with condensers *D-D* (Fig. 138) to give the variable unidirectional voltage *a-b-c-d*.

Instead of using several condensers and choke coils to smooth out the pulses of e.m.f. supplied to the plate of the power tube a single condenser, of sufficient capacity, might be used without choke coils. The required size of the condenser can be readily calculated if we assume the permissible variation in voltage applied to the plate.

Let us suppose the voltage furnished by one half of transformer *I* is given by the equation $e = E_m \sin \omega t$ and is shown in Fig. 139 at curve 1; this voltage is operative in one rectifier circuit and the voltage operative in the other rectifier circuit is shown at curve 2. The average voltage impressed on the plate of the power tube is shown by the dotted line V_0 , and the actual voltage is shown by the broken line *a-b-c-d*. At time t_1 the condenser *D* (Fig. 138) begins to charge because the voltage operating in rectifier *A* circuit becomes larger than the potential difference of the condenser plates. Neglecting the voltage required to cause saturation current to flow in the rectifier (which will generally be small compared to the voltage V_0 and E_m) we suppose the charging current of the condenser,

through rectifier A_1 to rise at once to its maximum possible value, i.e., saturation current of the rectifier, I_s . The condenser continues to charge at a uniform rate until some time t_2 , when the voltage across the condenser, which has been rising, becomes equal to the voltage of curve 1; at this time the current through the rectifier suddenly drops to zero.

From this time rectifier A is idle until one complete cycle later than time t_1 , when the operation is repeated.

From time t_2 to t_3 the condenser is discharging through the plate circuit of the power tube the voltage falling as indicated by the line $b-c$. At time t_3 rectifier B comes into play and the condenser voltage is again raised along the line $c-d$ and from time t_4 until rectifier A again begins its charging cycle the condenser voltage again falls.

The amount of potential drop from b to c is evidently fixed by the amount of current taken by the power tube and the capacity of the condenser used. If we call the time from t_1 to t_2 , which is the time the condenser is charging, θ , and if the average current taken by the plate circuit of the power tube is I_0 , it is evident that

$$I_0 \times \pi = I_s \times \theta \text{ or } \theta = \frac{I_0}{I_s} \pi.$$

With a given rectifier (fixing I_s) it is evident that θ is determined at once from the current, I_0 , required for the power tube. If V' is the maximum condenser voltage, at time t_2 , and V'' is the minimum condenser voltage at time t_3 it is seen that

$$I_0 \times \left(\frac{\pi - \theta}{\pi} \right) \frac{T}{2} = C(V' - V''),$$

in which T is the period of the impressed e.m.f. If the specified permissible fluctuation in condenser voltage is given this equation gives the required capacity of the condenser. If the fluctuation is expressed as a fractional part of the average voltage V_0 , that is

$$a = \frac{V' - V''}{2V_0},$$

we have,
$$\frac{I_0}{2V_0} \left(\frac{\pi - \theta}{\pi} \right) \frac{T}{2} = C \frac{V' - V''}{2V_0} = Ca.$$

From this relation we get as the required capacity of the condenser, after using the value of θ given above

$$C = \frac{I_0}{4afV_0} \left(1 - \frac{I_0}{I_s} \right), \dots \dots \dots (102)$$

in which f is the frequency of the alternating voltage.

From this equation the advantage of a high-frequency power supply is at once evident. As an example suppose the two rectifiers have an emission of current of 0.8 ampere, the frequency of power supply is 500 cycles, allowable variation of plate voltage of power tube to be ± 5 per cent, required average plate voltage 2000 volts and required plate current of 0.2 ampere. The condenser required is, from Eq. (102), 0.75 microfarad.

The required value of θ is

$$\frac{0.2}{0.8} \times \frac{\pi}{2} = \frac{\pi}{8} = 22.5^\circ.$$

By reference to Fig. 139 it is evident that E_m is approximately given by $\frac{V_0}{\sin \phi}$; in the above example $\phi = 78.8^\circ$ so

$$E_m = \frac{2000}{.98} = 2050 \text{ volts.}$$

Actually this voltage would be considerably too low; we have neglected the drop of voltage in the rectifiers which would probably be 200 volts which makes the required value of E_m about 2250 volts. As this voltage is that of one-half of the secondary of transformer winding I (Fig. 138) it is evident that the winding should give a maximum voltage of 4500 volts. If we consider the reactance and resistance of winding I other slight corrections would be required making it advisable perhaps to specify a voltage of 5000 (maximum) for this transformer.

It may sometimes be worth while to consider the proper values of ratio of V_0 to E_m from the standpoint of overall efficiency. Thus the power used in heating filaments A and B (Fig. 138) is expended throughout the cycle, whereas we have assumed the emission current to be used but a small fraction of the cycle. In the problem worked out above it might pay to cut down the amount of power used in heating the filament, thus cutting down I_s , making θ larger. Before this point could be treated analytically it would be necessary to know the relation between emission current and required filament power. At present, with tungsten filaments it requires from 50 to 100 watts per ampere of emission, if the filament is operated at such a temperature that its life may be 1000 hours or more.

For average conditions a value of θ of $\frac{\pi}{2}$ seems right.

Use of a Separate Exciter for a Group of Tubes.—It is not always possible to get as much power from a self-excited tube as from a separately excited one, and the adjustment for such a condition is critical; if it is used, the tube may stop oscillating when a slight drop in plate voltage or filament current occurs. This is a dangerous condition, because unless

the operator notices at once that the tube is not oscillating the plates will rapidly become overheated and the tube perhaps spoiled. To avoid this contingency a separate exciting tube may be used, this tube furnishing only enough power to operate its own circuit and supply the losses in the grid circuits of the group of power tubes. Such a scheme is shown in Fig. 140; the exciter tube *A* is adjusted with tight coupling between L_2 and L_1 , so that it oscillates under any condition which may occur, and the power tubes *M*, *N*, etc., are each excited by a common connection to tube *A*. By adjustment of the condensers C_1 — C_2 , etc., the output of each power tube may be controlled, this control being in addition to that

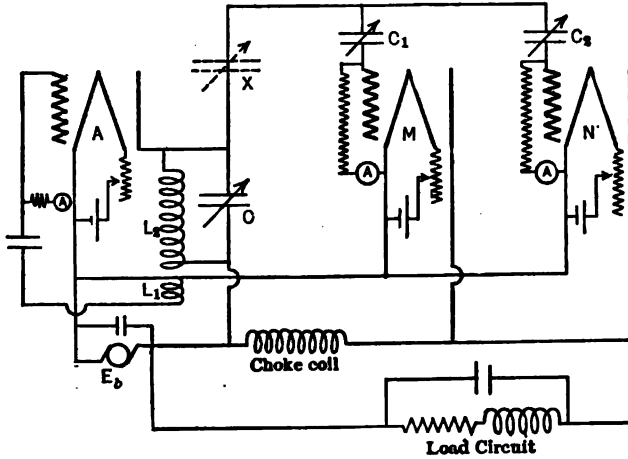

FIG. 140.—When many tubes are to operate in parallel it is generally best to excite them from a separate tube *A*, self-oscillating, controlling the amount of excitation by condensers C_1 — C_2 , etc.

afforded by the filament current. The frequency of the exciter circuit must of course be that required for resonance in the load circuit of these power tubes.

In case the individual control of the excitation is not desired a common adjustable condenser may be inserted in the exciter lead where indicated by the dotted lines at *X*; this condenser should have a reactance about equal to the impedance of the combined input circuits of the power tubes.

Although the largest tubes made to-day permit a power consumption in the plates of not more than 250 watts, thereby limiting the power output to about twice this amount, it seems likely that tubes of much greater capacity will soon be obtainable; water-cooled plates are an obvious necessity and a steel tube, instead of glass, with continuous pumping by a mercury-vapor pump during use, seem to be likely developments.

Another scheme for using an exciter tube for maintaining the power tube in oscillation is shown in Fig. 141. In this case the exciter tube

is not a self-exciting unit, but operates in conjunction with the power tube; the frequency of output is determined entirely by the $L-C$ circuit of the power tube.

The amount of excitation furnished to the grid of the exciter tube depends upon the relative magnitudes of C_2 and C_3 ; ordinarily C_3 should be many times as great as C_2 . The value of the resistance R may vary widely, a suitable value being equal to the resistance of the plate-filament circuit of the exciter tube.

This arrangement is a very useful one if it is desired to vary the frequency of the output circuit over a wide range; in a typical case the frequency of the output circuit was varied (by changing L and C) from 500 to 300,000 cycles per second without changing the adjustment of the

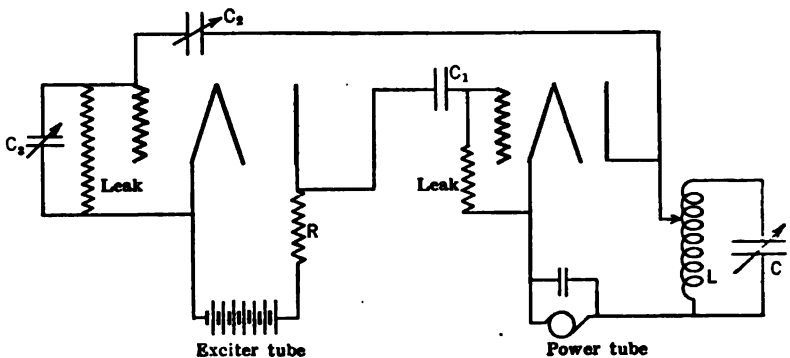

FIG. 141.—A scheme for using an untuned exciter tube; this scheme is a good one if the set is to oscillate with very wide variations in the values of L and C .

exciter tube and a wider range could have been covered without any other adjustments than those of L and C , had it been so desired.

Special Forms of Tubes—Dynatron—Pliodynatron.—In a special form of three-electrode tube, first advocated by A. W. Hull and called by him the dynatron (see Fig. 21, p. 389, for picture of dynatron), the phenomenon of secondary emission is utilized. If an electron traveling at high speed collides with a metallic surface, the giving up of its energy at the surface is likely to "jar" other electrons out of the metal at the point where the collision occurs; the emission of the electrons from this surface, caused by the colliding electron, is called *secondary emission*. The number of electrons emitted depends upon the speed of the colliding electron; it may be none at all and may be as much as a dozen or more.

Ordinarily these electrons due to secondary emission will at once re-enter the surface from which they have been emitted, but, if there happens to be in the vicinity of the surface an electrode of higher potential, these secondarily emitted electrons will not re-enter the surface from which they came but will go to the higher potential electrode, thus causing

electron current *away* from the surface to which the first electron is traveling.

The number of electrons taking part in this reversed current depends upon the number caused by the secondary emission and upon the potential of the surface attracting them. Suppose the arrangement of electrodes as given in Fig. 142; the grid is at higher potential than the plate and so attracts most of the electrons caused by the normal thermal emission from filament *F*. However, some of these electrons will go through the interstices of *G* and impinge on *P*, causing secondary emission where they strike. As *G* is at higher potential than *P*, the electrons due to secondary emission are likely to go to *G* instead of re-entering *P*.

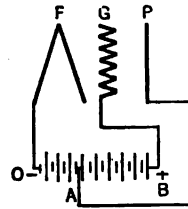

FIG. 142.—Connection of a three-electrode tube to get the characteristics of the dynatron.

If the potential of *G* is held constant (contact *B* remaining fixed) and the potential of *P* is gradually increased from zero by moving contact *A* to the right, the various happenings will be about as shown in Fig. 143.

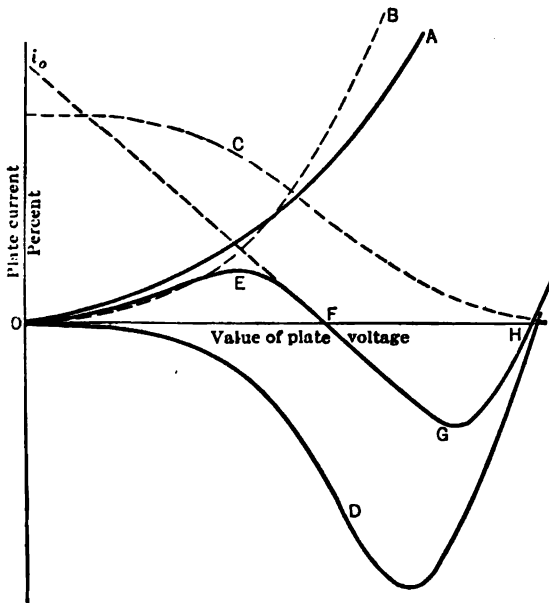

FIG. 143.—Curves of various currents occurring in the operation of the dynatron.

Curve *O—A* shows the electron current to *P* due to emission from *F*; curve *O—B* shows the amount of secondary emission from *P*, due to electrons of current *OA*; curve *C* shows the fractional part of the secondary emission which is attracted to *G*; curve *O—D* shows the electron current away from *P* due to secondary emission, and curve *OEFGH* shows the actual electron current to *P*, all of these curves being plotted for increasing plate potential.

The peculiarity of that part of the curve from *E* to *G* is the basis of action of the dynatron; an increasing plate potential results in a decrease in plate current. in other words, an alternating-current test of the resistance

of the plate-filament circuit in this region of operation would show a negative resistance.

The dynatron has thus practically the same characteristics as an ordinary three-electrode tube with the regenerative connection of plate and grid circuits, and it may be used for similar purposes.

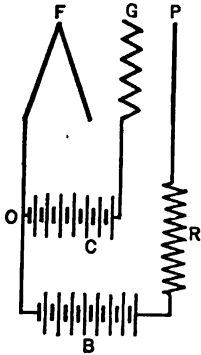

FIG. 144.—Connection of three-electrode tube as a dynatron.

The current curve of Fig. 143, between points *E* and *G*, can be expressed by the equation,

$$i = i_0 - \frac{v}{r} \dots \dots \dots (103)$$

where

- i* = plate current;
- i*₀ = value of plate current obtained by projecting the curve *GFE* back to *v* = 0 as shown in Fig. 143;
- r* = internal resistance of the tube determined from the slope of the *GFE* curve.

Transposing the terms of Eq. (103) we have

$$v = r(i_0 - i)$$

If the voltage of the battery *B* (Fig. 144) is *E* and the drop across the resistance *R* is *V*, then

$$E = V + v = Ri + r(i_0 - i) = (R - r)i + ri_0 = \frac{(R - r)V}{r} + ri_0.$$

Then

$$\frac{dV}{dE} = \frac{R}{R - r} \dots \dots \dots (104)$$

As *R* - *r* may be made small, it is evident that a small increase in *E*, the voltage used in the plate circuit, may result in a much larger change in the voltage drop across *R*. It has been possible to regulate the tube so that an increase of one volt in *E* has resulted in a change of the potential difference across *R* of 100 volts, thus giving a voltage amplification of 100 times.

The dynatron may be used as regenerative detector, oscillating detector of continuous waves, or as a generator of alternating-current power just as can the ordinary three-electrode tube; it is not evident, however, that it has any advantage over the three-electrode tube as ordinarily used.

It is possible to add a fourth electrode to a dynatron and thus make it act as a normal three-electrode tube in addition to the effects obtained from secondary emission. A possible connection of such a tube (called the *pliodynatron*) is shown in Fig. 145. By suitably adjusting the two e.m.f.'s *OB* and *OA*, the circuit may be made to oscillate at a frequency

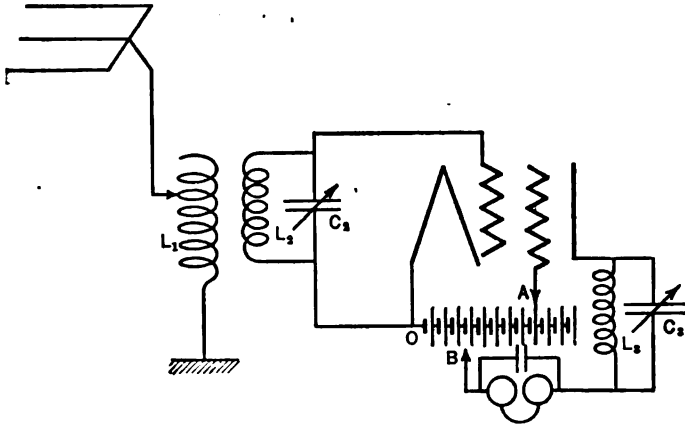

FIG. 145.—Connections of the pliodynatron.

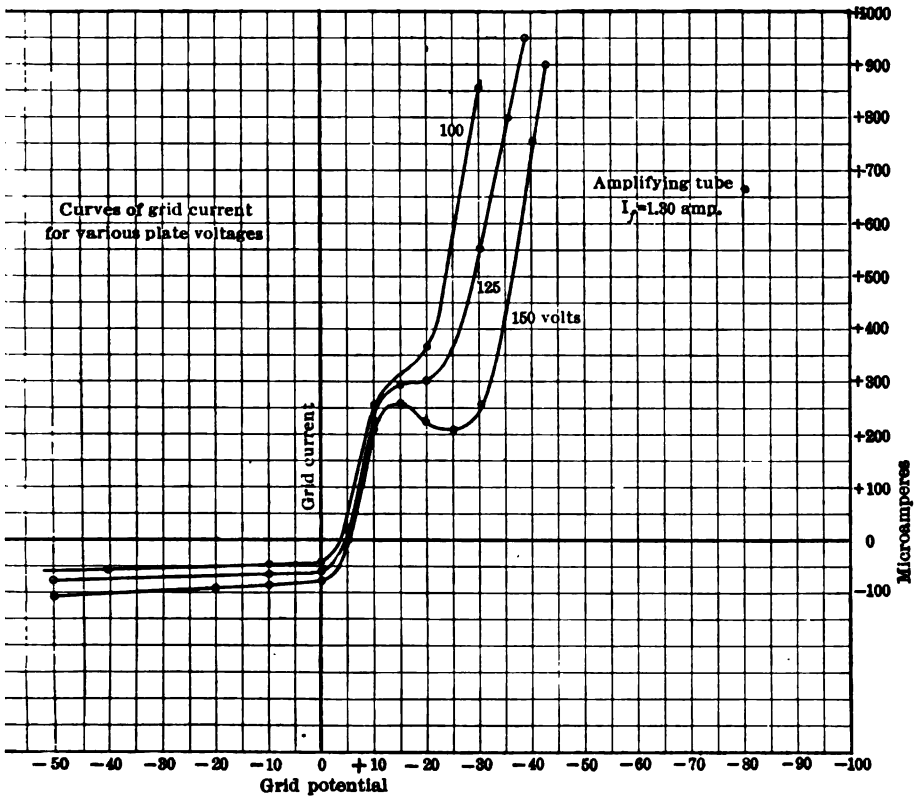

FIG. 146.—Dynatron characteristics in an ordinary telephone repeater tube.

determined by L_3-C_3 ; so adjusted it acts as an amplifying receiver for continuous waves; with slightly different voltage OB it may be made to act as an efficient detector of damped waves.

The special forms of plate current curve for the dynatron given in Fig. 143, may be duplicated to some extent by any three-electrode tube; in Figs. 146, 147, and 148 are shown the curves of grid current of an ordi-

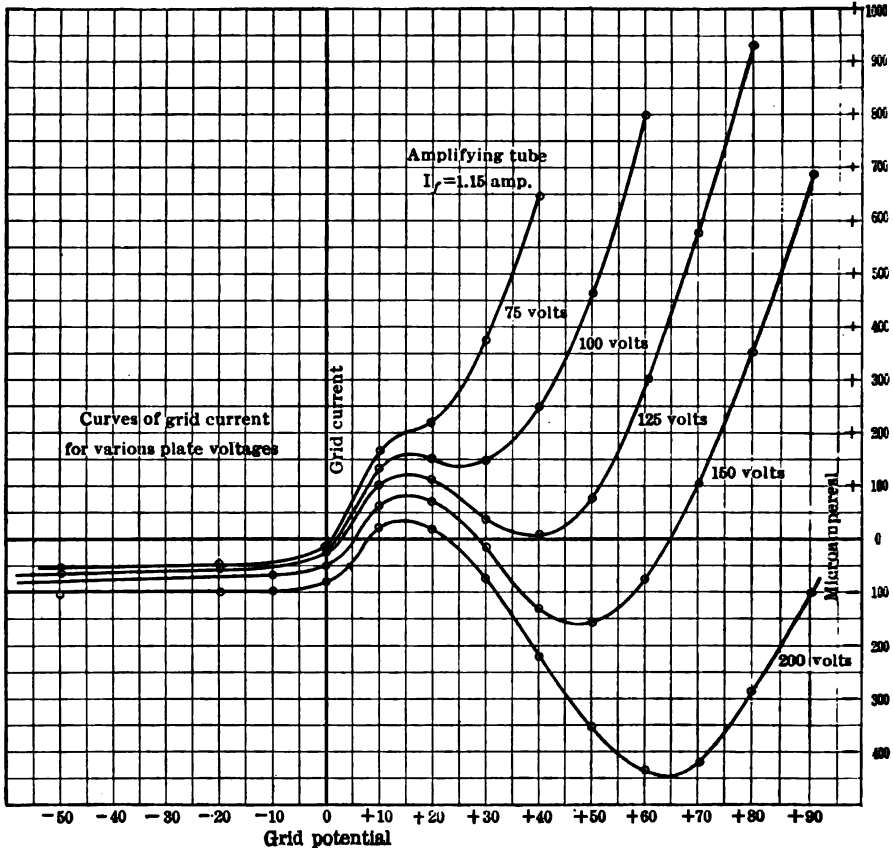

FIG. 147.—Dynatron characteristics in an ordinary telephone repeater tube.

nary telephone amplifying tube operated outside its normal range. This tube normally operates with a negative grid, but by carrying the grid through sufficiently high positive potentials the form of its current is made to resemble that of the dynatron very closely. The tube was not pumped to as high a vacuum as are the dynatron and plotron, so that there was more gas present in this tube, but the regularity of the curves and the fact that they could be duplicated as many times as desired shows that

however much gas there was present, it was playing a minor role in the action of the tube.

Detailed Study of the Three-electrode Tube as a Power Converter.—The foregoing analyses of the conditions for oscillation of a three-electrode tube have all been based on the assumption that the plate current in the oscillatory condition could be sufficiently well represented by a constant current with a sine-wave current superimposed, and on this basis we have shown that the theoretical maximum output of the tube was one-

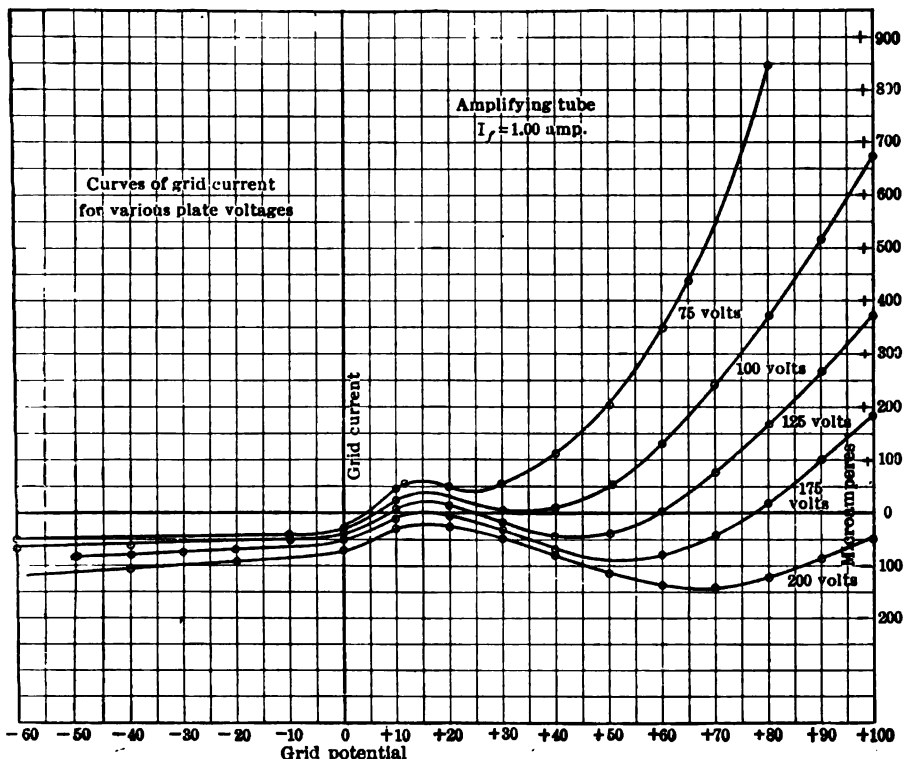

Fig. 148.—Dynatron characteristics in an ordinary telephone repeater tube.

half of the input; the fact was also mentioned that the conditions demanded for this efficiency of 50 per cent could not be realized, so that we were forced to conclude that the maximum efficiency of a tube generator was about 40 per cent.

The author with the assistance of Mr. H. Trap Friis¹ carried out a detailed study of the tube generator for both separate and self-excitation, and it was found that the efficiency might become very much higher when the proper adjustments were made; part of the results of this study

¹ Proceedings of A.I.E.E., Vol. 38, No. 10, Oct., 1919.

will be given here, as they show exactly how a tube functions. The notation used in this analysis is somewhat different from that used so far because the previous symbols are not applicable. The plate current cannot be represented by $I_{op} + I_{mp} \sin \omega t$, as has been previously assumed; it consists of a series of pulses so that an infinite series of sine terms would be required to represent the alternating component. The plate voltage also does not have exactly a sinusoidal variation. We therefore represent the instantaneous value of the *actual* plate voltage by e_p , grid voltage by e_g , plate current by i_p , grid current by i_g , etc., instead of representing each by a constant plus a sine term.

Oscillograms were taken to show the various quantities entering into the operation of the tube and circuit, the frequency of the alternating current being between 100 and 200 cycles; later the circuit constants were diminished sufficiently to raise the frequency to 100,000 cycles, to

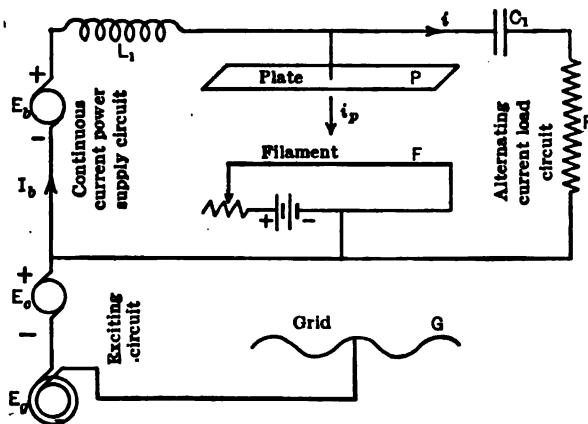

FIG. 149.—Connection of power tube for study of its characteristics.

show that the results obtained at the lower frequency (which allowed accurate oscillographic records to be obtained) were valid at radio frequencies.

The first effect studied was the change in form of e_p and i_p as the excitation of the grid was increased, using a separately excited circuit as indicated in Fig. 149.

The reactance of C_1 was 62 ohms and of L_1 was 8700 ohms; the value of R was 1000 ohms and the resistance of L_1 was 190 ohms. The μ_0 of the tube used was 3.9.

With comparatively low values of E_c and E_g , a record was taken of e_p , i_p , and i_g , and is given in Fig. 150; it is seen that the fluctuations in e_p and i_p were nearly sinusoidal so that the results of the previous analysis would hold good for this condition. Upon increasing e_g to six times its value the forms of e_p and i_p are made to differ widely from sine forms, however, as shown in Fig. 151.

An interesting point is shown by the film; the value of R used was 1000 ohms and this is the value which gives, for this tube, maximum output for low values of E_g , as shown in Fig. 94. This value 1000 ohms

must therefore be the tube resistance R_p for the low value of E_g . But with large excitation used in Fig. 151 the plate current evidently fluctuated much as possible (from zero to saturation current) and the fluctuation e_p is less than half of E_b , indicating that R should be more than doubled. This it will be remembered has been predicted as necessary when i_p fluctuates between zero and saturation current, and e_p fluctuates between the limiting values of zero and E_{op} . With a resistance load of the kind shown in Fig. 149 it is evident that such a wide variation in the value of e_p is impossible; the load cir-

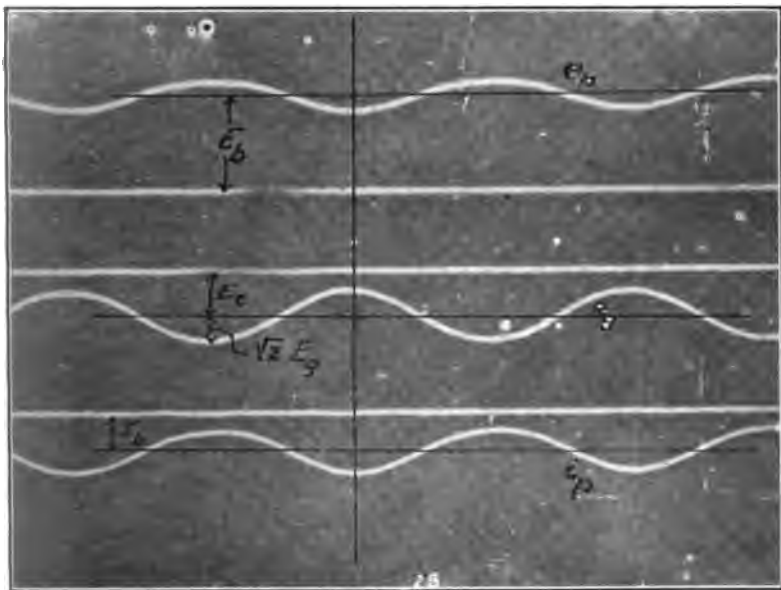

Fig. 150.—Nearly sinusoidal variations in e_p and i_p for low grid excitation. $E_b = 900$, $I_b = .25$, $E_c = 120$, $E_g = 50$, Frequency = 140, $R = 1000$, $C = 18.4$ microfarads.

cuit must contain inductance and capacity to cause e_p to fluctuate so widely. This point is taken up later on in this section.

If R is still further reduced the distortion in e_p and i_p will appear with much lower values of E_g ; in Fig. 152 is shown a record for a value of E_g of 100 volts with R only 100 ohms. The fluctuation in e_p is now hardly noticeable although i_p fluctuates, with distorted form, from zero to saturation current as before. The current taken by the grid in Figs. 150 and 152 was zero; in Fig. 151 the grid swings positive 300 volts so we might expect a large grid current, but it is shown to be small. This is due to the fact that the plate is at rather high potential (650 volts) during the time the grid is positive, so that but few electrons go to the grid.

Fig. 151 shows also the fluctuation of I_b ; in spite of the large inductance L_1 (which was 10 henries) there is considerable variation in I_b . This must of course always be the case; the value of $L_1 \frac{di_b}{dt}$ must at any instant be equal to the difference between E_b and e_p .

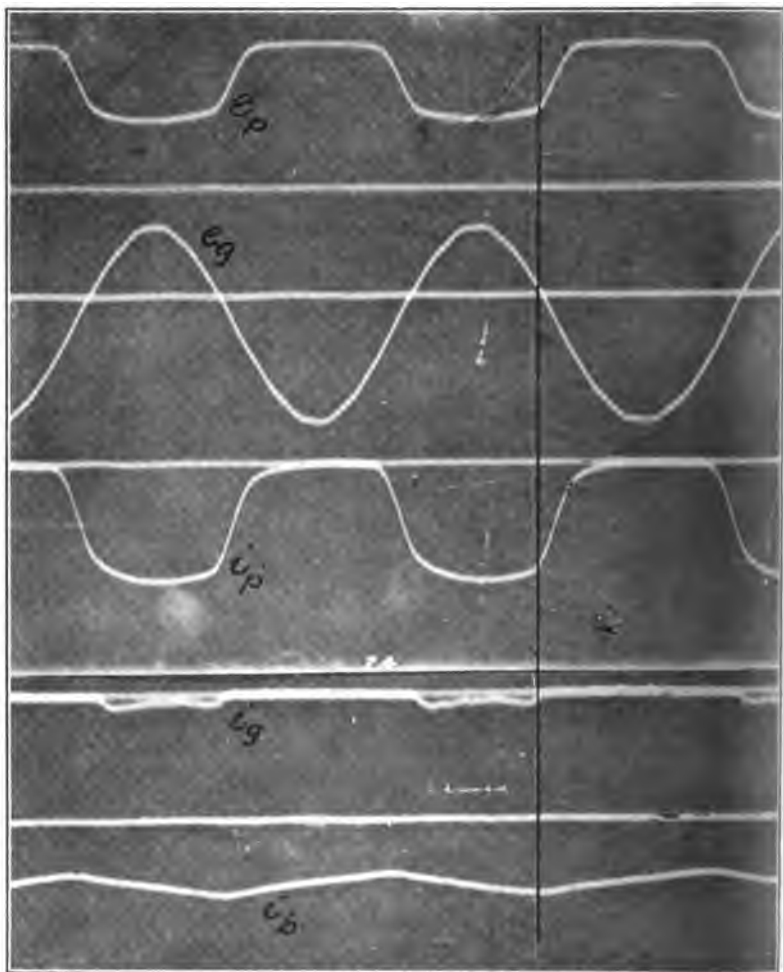

FIG. 151.—Distortions occurring with higher grid excitations. $E_p=900$, $I_b=34$, $E_c=120$, $E_g=300$, $f=140$, $R=1000$, $C=18.4\mu f$.

In Fig. 153 are shown the curves of e_p , i_p , and e_o for two values of R , all other conditions being the same; it may be seen that the amount of distortion in i_p is reduced as the value of R is increased. In getting these two films the value of L_1 was kept constant, with the result that

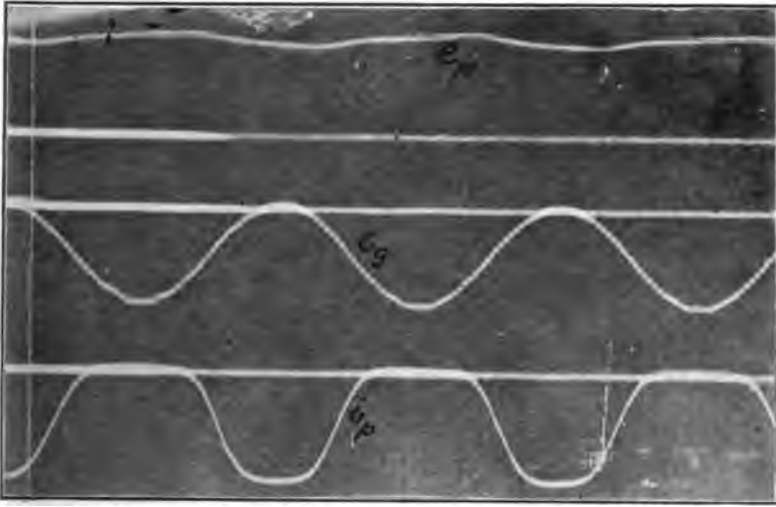

FIG 152.—With low load circuit resistance distortions occur for even low grid excitation.
 $E_b=900$, $I_b=.34$, $E_c=120$, $E_g=100$, $f=140$, $R=100$, $C=18.4\mu f$.

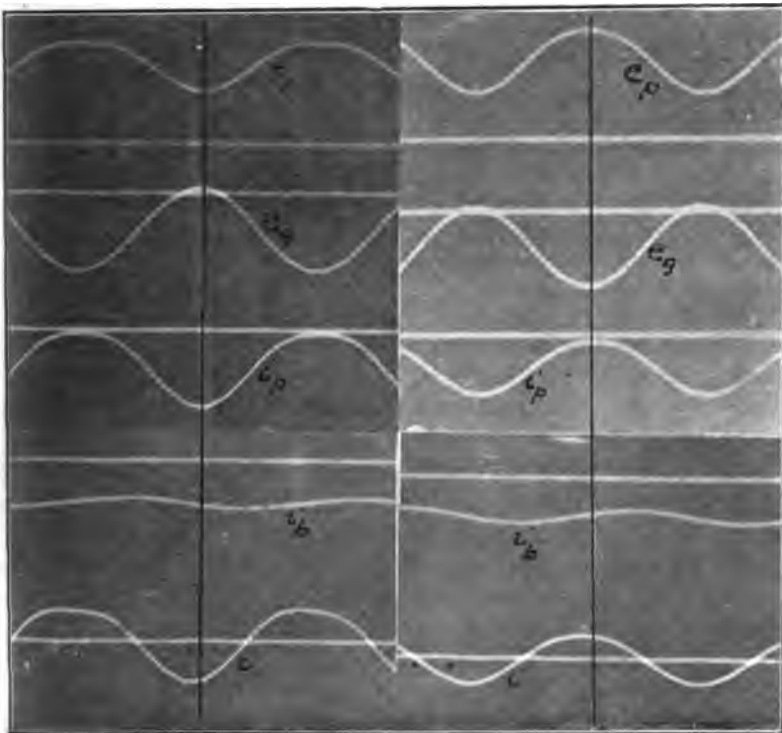

FIG. 153.—Showing effect of load resistance on forms of voltage and current, other conditions constant. For both films $E_b=900$, $E_c=120$, $E_g=100$ and $f=140$. For left-hand film $I_b=.295$, $R=1000$. For other $I_b=.272$, $R=2010$.

a larger percentage of the generated alternating current of the tube went through this path, with the higher value of R , instead of through the load circuit, $C_1 - R$.

Attempts were then made to see what adjustments of the tube and associated circuits gave best efficiency; the importance of high efficiency will be at once appreciated when it is mentioned that a given tube (the one used in these tests) has an output of about 200 watts in normal operation whereas if the efficiency could be raised to 90 per cent, the safe output would increase to 2250 watts.

The tests carried out involved an adjustment with separate excitation to find the conditions for maximum output and then transferring the grid connection to a proper point of the circuit to get self-excitation, recording

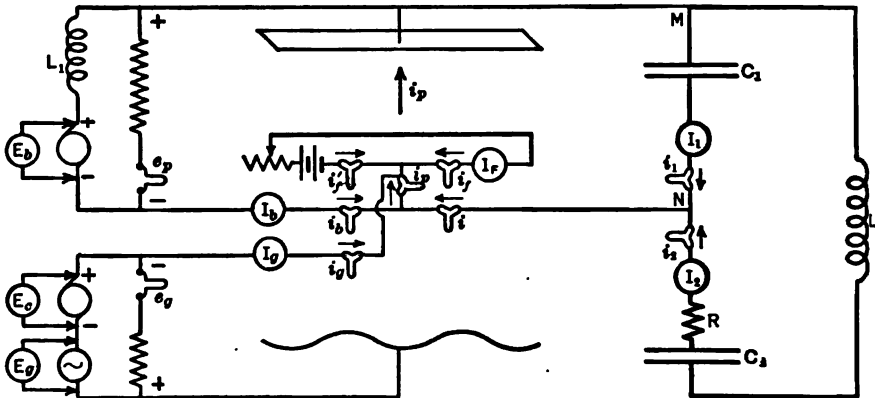

FIG. 154.—Connection of the power tube to a tuned output circuit, showing where oscillograph vibrators were introduced and directions of current assumed as positive (above zero line in oscillograms).

for each condition the forms and phases of currents and e.m.f.'s. The tests were run at low frequency so that oscillograph records might be obtained; the results obtained were duplicated later in a high frequency run.

Fig. 154 shows the circuit used; simpler ones may be used, but the laboratory apparatus at hand was best suited to this one. The diagram also shows where the oscillograph vibrators were introduced and the direction of currents assumed as positive; if, on a film, a current is shown below its zero line, it was flowing in the opposite direction to that shown in the diagram. If the frequency of the exciting voltage, E_e , is chosen the same as the resonant frequency of the load circuit

$$f = \frac{1}{2\pi\sqrt{L\left(\frac{C_1 C_2}{C_1 + C_2}\right)}}$$

the impedance of this circuit between the two points *M* and *N*, where the tube is attached, will be resistive only, its magnitude being equal to $\frac{1}{\omega^2 C_1^2 R}$ ohms.

The quantities to be considered are shown conventionally in their proper phases in Fig. 155; the current *i*₁, which flows in the resonant load circuit, may be several times as large as the current *i*, furnished by the tube. The two important things in this diagram are shown in the lower part of the figure, namely, the curves of *e*_{*p*}*i*_{*p*} and of *e*_{*p*}*i*. These curves give the power loss on the plate and the power supplied by the tube to the load circuit, respectively. It is at once evident that

$$\text{Energy loss on plate per cycle} = \int_0^{2\pi} e_p i_p dt = \text{Area A.}$$

$$\text{Energy supplied to load circuit} = \int_0^{2\pi} e_p i dt = \text{Area C} - \text{Area B.}$$

It is evidently desirable to make the latter as large as possible and the former as small as possible, if the tube circuit

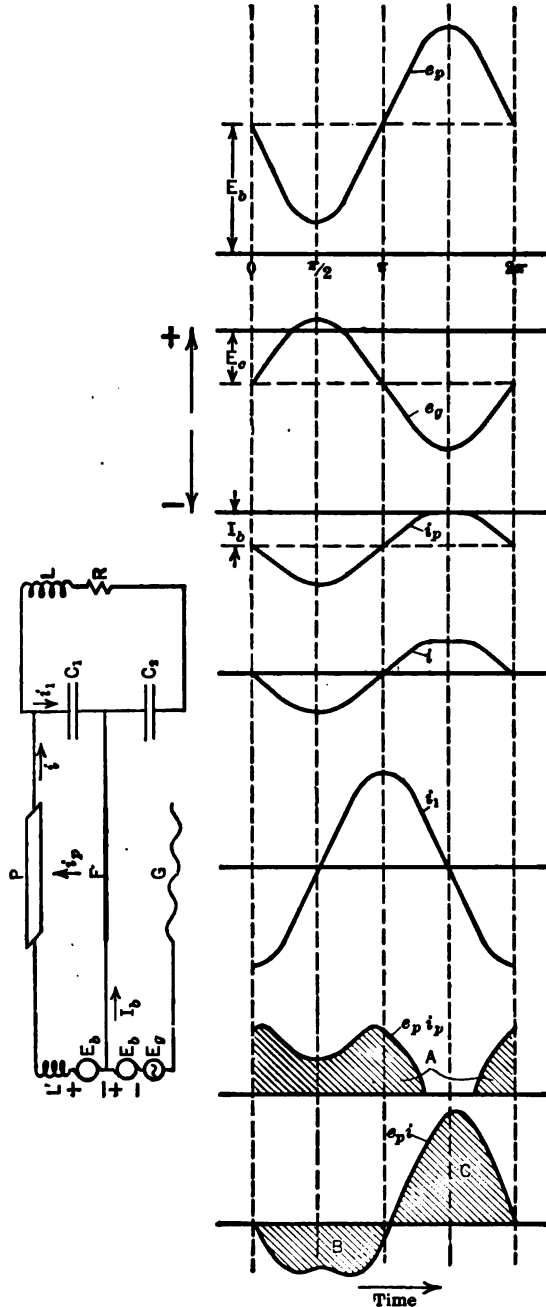

FIG. 155.—Showing the important variables to be studied in determining tube efficiency.

is to operate efficiently. Any ordinary scheme of analysis, using the relation given in Eq. (5), p. 417, must fail because the relation does not hold good for those values of e_p and e_g , which are the most important ones in the cycle of operation, namely, low e_p with positive e_g , and very high values of e_p with large negative e_g .

The ordinary so-called static characteristics of the tube used are given in Fig. 156; they are not of much service in predicting the behavior of

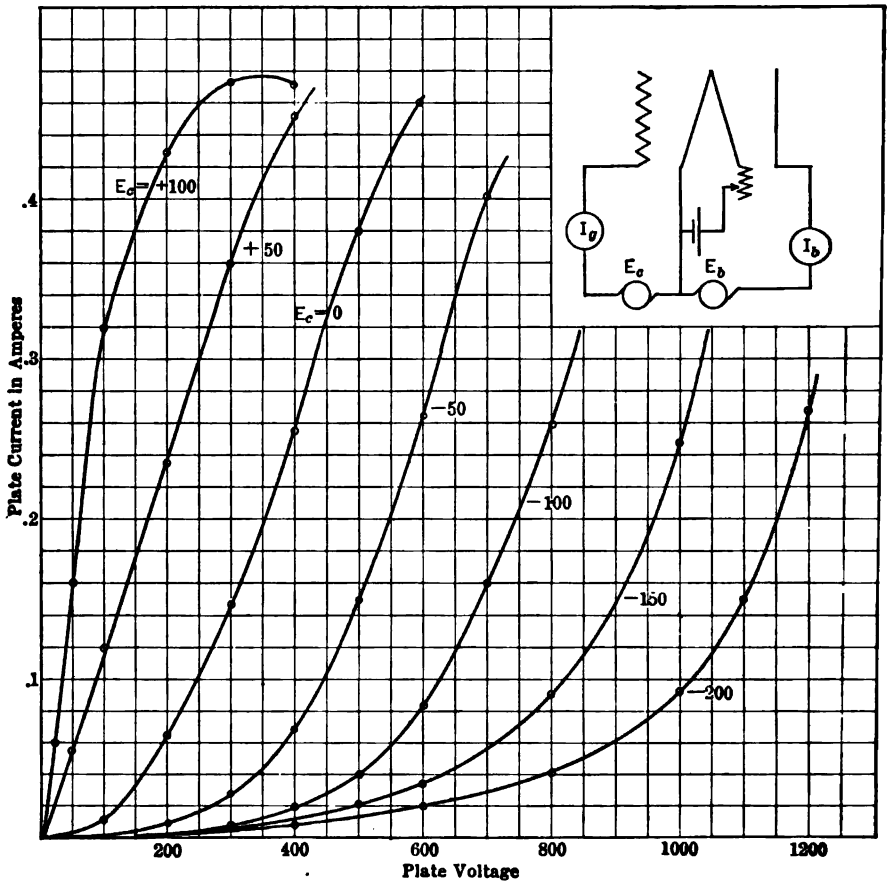

FIG. 156.—Static characteristics of the plitron used in making the tests.

the tube when the output is forced as high as possible. They did bring out the fact, however, that the filament ammeter, if a continuous-current instrument, does not read correctly the filament current when the tube is generating alternating-current power. The ammeter indicated 3.65 amperes when getting the curves of Fig. 156 and the total emission for such a current is evidently about 0.5 ampere. Now when the tube was oscillat-

ing, the filament ammeter reading 3.65 amperes, the total emission was about 0.8 ampere, showing that the filament temperature was much hotter than when not oscillating. Holding the voltage across the filament constant (approximately the condition when the tube is oscillating) the set of curves

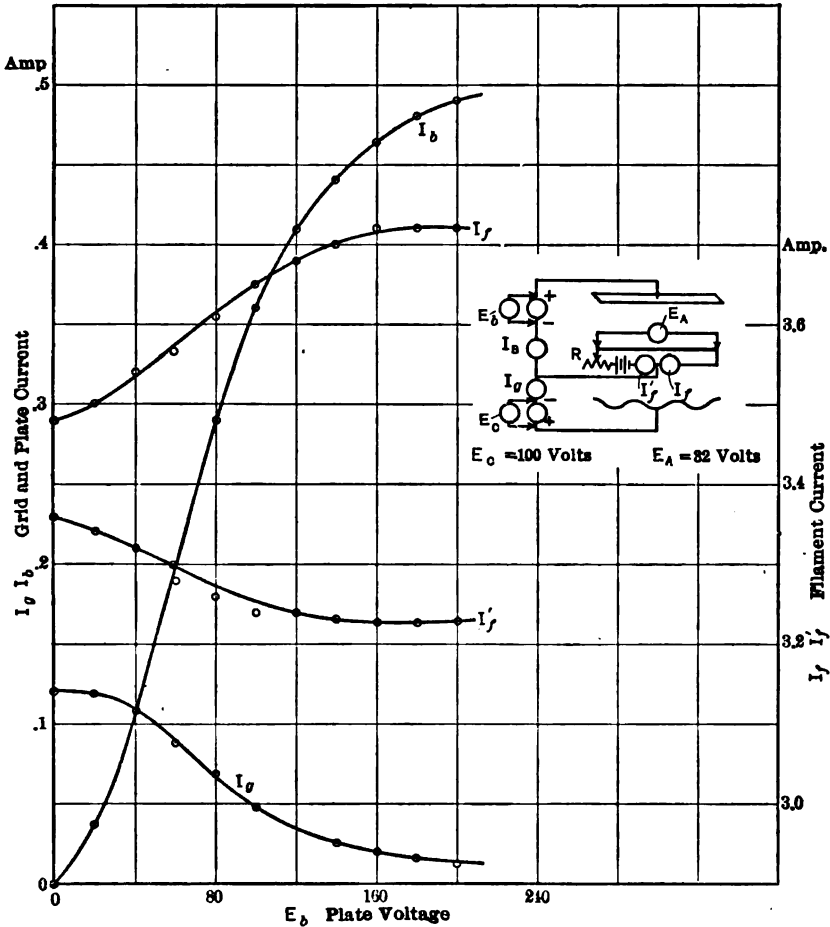

FIG. 157.—This set of curves shows how the filament current changed as the plate voltage was increased; even with 3.75 amperes in that end of the filament carrying the larger current the emission was only .5 ampere, whereas when oscillating this same tube gave an emission of .8 ampere with an indicated filament current of only 3.65 amperes.

given in Fig. 157 were obtained. The grid was held at a positive potential of 100 volts and the plate voltage suitably varied. The electron current to the plate increases the filament current at one end and decreases it at the other; the relative values of increase and decrease will be deter-

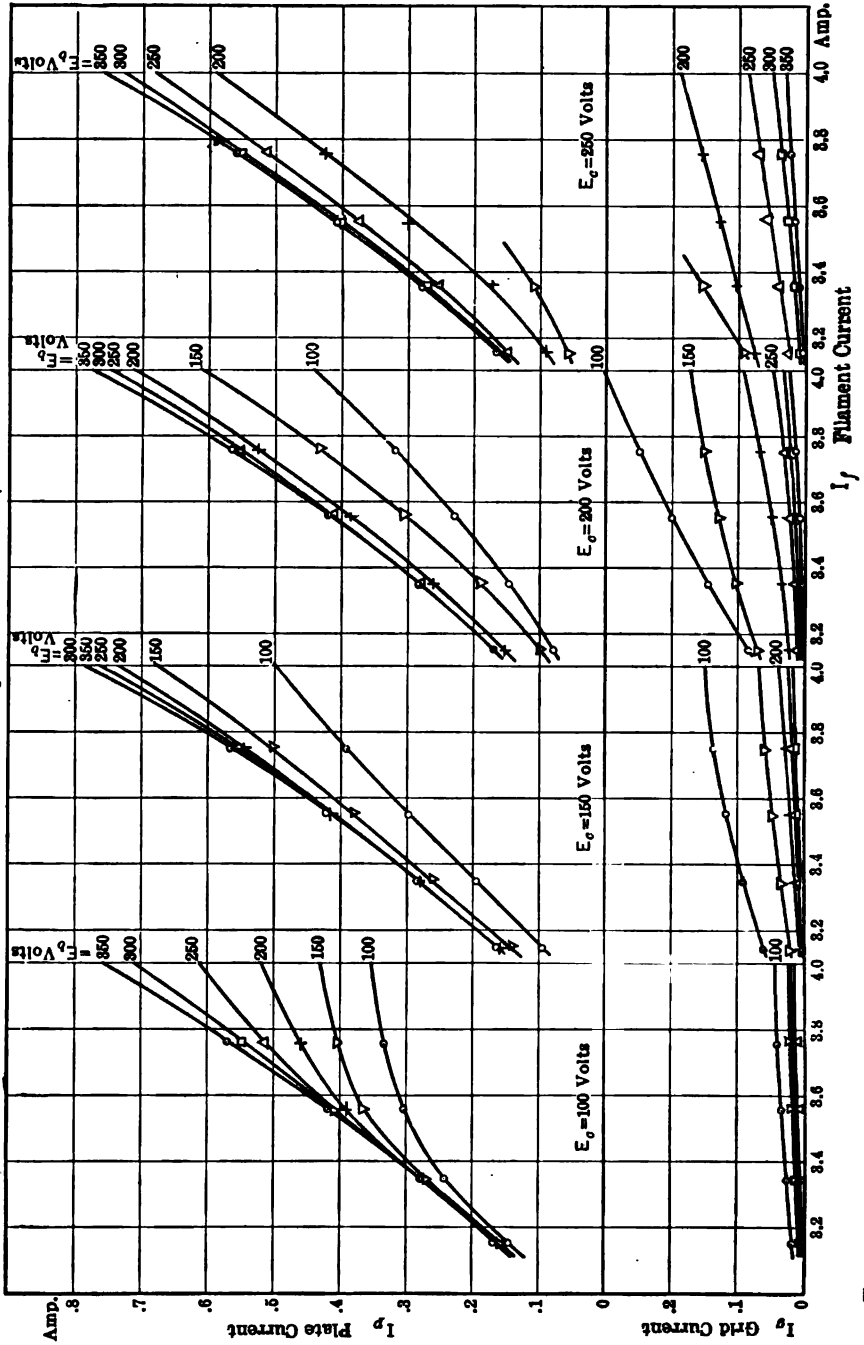

Fig. 158.—Plate currents and grid currents of the tube for various fixed grid and plate voltages, filament current being varied.

mined largely by the resistance used in series with the filament battery. It can be seen that even with the larger filament current as great as 3.75 amperes the emission was only 0.5 ampere.

From some preliminary oscillograph records we knew that in operation the total emission was about 0.8 ampere when the filament ammeter read 3.65 amperes. A brief test showed that the filament current required

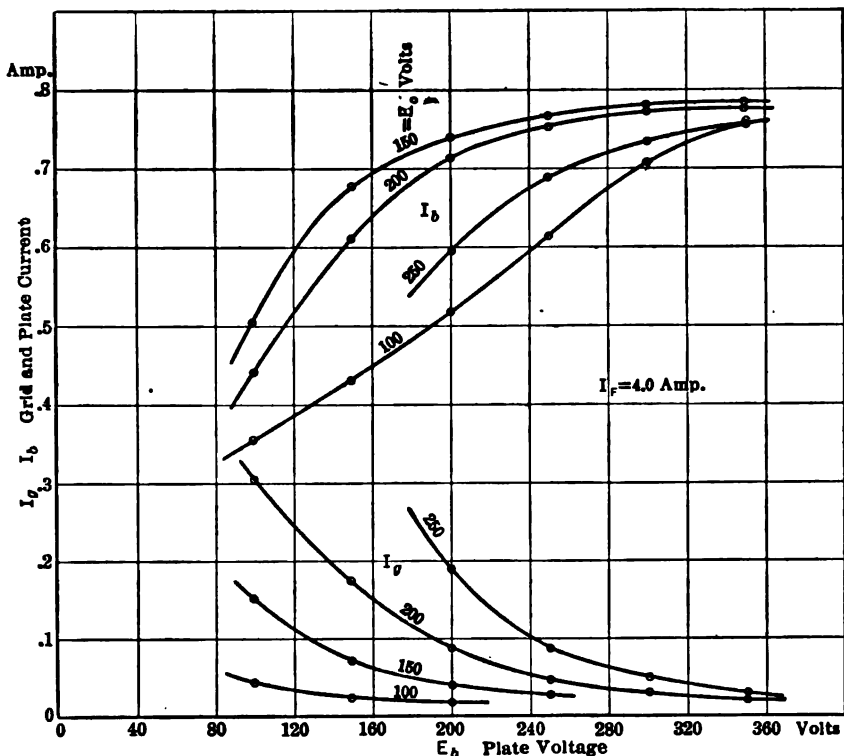

Fig. 159.—Grid and plate currents for various fixed grid potentials and variable plate voltage, filament current at 4.0 amperes; these curves were obtained by extrapolation in Fig. 158. The numbers noted on the individual curves signify the grid potential (positive) the lower set of curves being grid current and upper set plate current.

to give this much emission was 4.00 amperes, but this seemed like an excessive current at which to carry out a test, so we got the characteristics required from extrapolation. In Fig. 158 are shown a set of curves showing the variation of plate and grid currents for various filament currents and grid and plate potentials, they being extrapolated for the higher filament currents. From this set of curves the results given in Fig. 159 were obtained; as these are important curves they were verified for correctness of form by actually getting them for a lower filament current.

These are given in Fig. 160 and are of just the same form as those of Fig. 159.

It is well to point out here that even if we had been able to get the curves of Fig. 159 with a filament current of 4.00 amperes they would not have given the proper values of i_p and i_g for the tube in operation. While getting these static characteristics the plate and grid get very hot, much hotter than when the tube is in operation as a generator. The emission from the filament is fixed by the filament temperature, and this in turn is fixed by the filament current and the temperature of the plate; if this is hotter when getting the static characteristics than when the tube is generating, the values of i_p and i_g obtained would probably be too large.

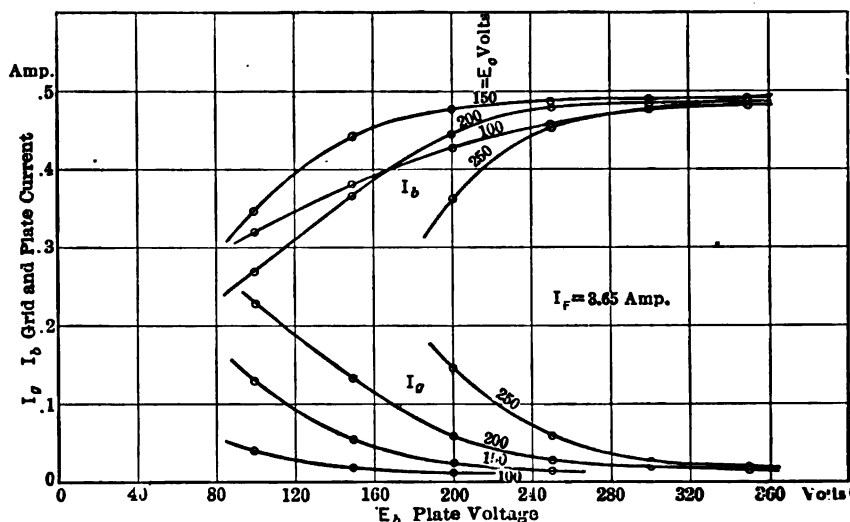

FIG. 160.—As the curves of Fig. 159 are important, and they were obtained by extrapolation, they were verified for correctness of form by picking off from Fig. 158 a similar set of curves for a filament current of 3.65 amperes; evidently these curves are of the same form as those of Fig. 159.

The curves of Fig. 159, in connection with Fig. 155 enable us to at once give the minimum potential to which the plate should drop and the maximum positive potential for the grid. In order to make the area A (Fig. 155) small the plate potential, at time $\frac{\pi}{2}$, should be as low as possible. This minimum will be controlled, however, by the other requirement that the area C should be large. If, during the time when e_p is low, i_p does not have its maximum possible value (saturation current) then the positive alternation of i will not be as large as it should be and if this is not large the power input to the load circuit, determined principally by the area of C , will be lower than its proper value.

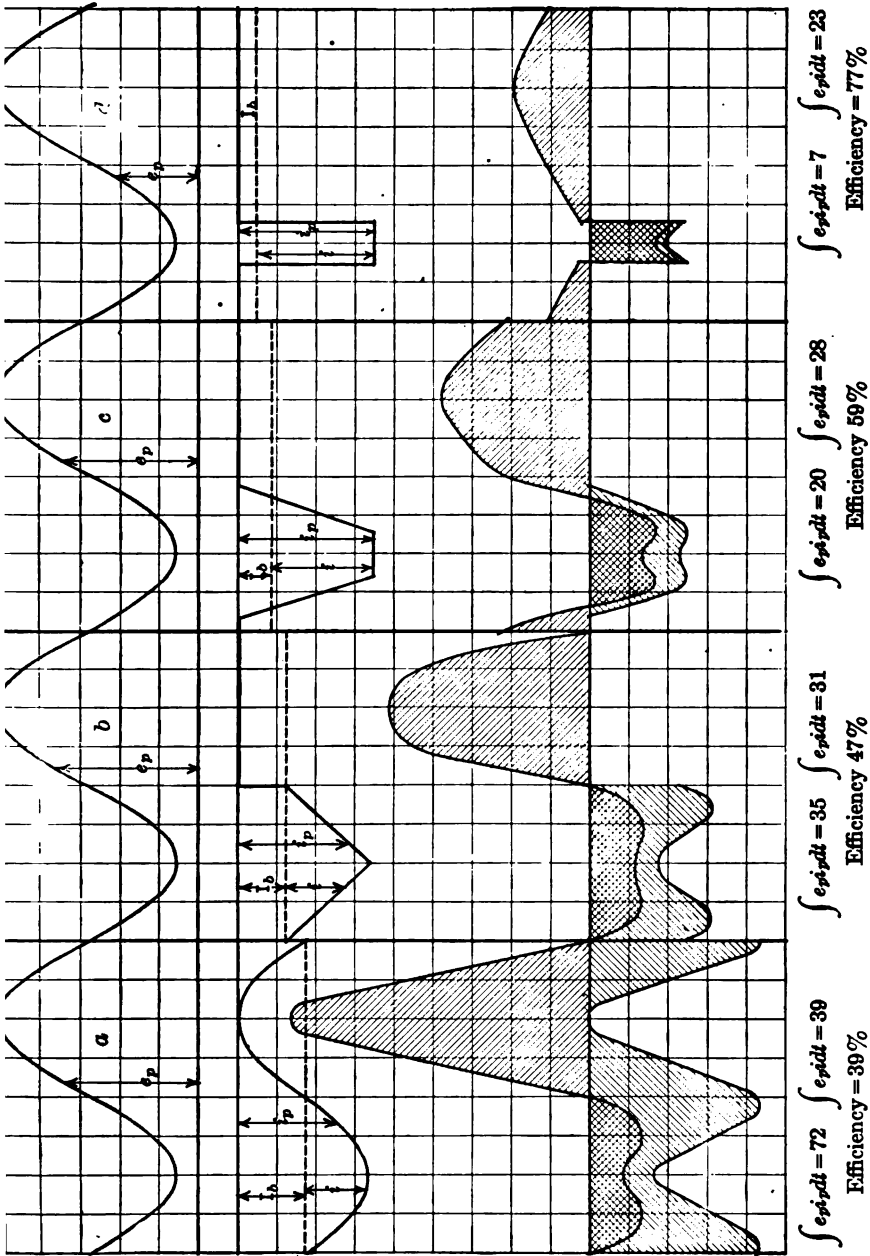

FIG. 161.—In this figure various forms of plate current have been assumed and (plate voltage remaining fixed in shape) the resulting efficiencies calculated.

As the average value of i must be zero, if its positive loop is to be as large as possible, and the area of A to be kept as small as possible, the conditions should evidently be so adjusted that, at minimum plate potential, saturation current should flow, and this flow should last for a short time only. During the rest of the cycle the plate current should be zero.

Fig. 161 shows the calculated losses on the plate and input to the load circuit for four different forms of plate current, the plate voltage having the same form for each. It will be seen that both the losses and the output of the tube are greatest for the sinusoidal plate current, but the efficiency for this condition is only 39 per cent; as the form of plate current approaches a short pulse the efficiency increases, being 77 per cent for the form shown in curve (d). The trapezoidal form shown at (c) resembles very closely the form we used; the test actually gave about 60 per cent efficiency.

All four curves are drawn with the maximum plate current the same, supposedly the saturation current for the filament current used; by carrying out other constructions it will be evident that any other condition would result in poorer operation.

By now referring to Figs. 155 and 159 it may be seen that for the tube we were using the plate potential should not fall lower than 200 volts, that at this time the grid should have a positive potential of 150 volts. With greater or less grid potential, the plate potential being 200 volts, the plate current would be less than saturation value; with less plate potential the current (at time $\frac{\pi}{2}$, Fig. 155), would be less than saturation value, and with greater voltage than 200 volts the loss on the plate would be greater than necessary.

It is to be noted that the efficiency will increase for all the cases given in Fig. 161, if the value of the power supply, E_b , is increased, providing that conditions are suitably changed to have the same minimum plate voltage as given in Fig. 161. This is shown by Fig. 162; the two cases given suppose the same form of plate current and same minimum value of plate voltage, but in the second the voltage E_b is about twice as large as in the first case. It is seen that the loss on the plate is increased only 25 per cent whereas the input to the load circuit has been more than doubled. The higher the value of E_b the higher is the efficiency, the limit being fixed by the safe voltage for the tube.

In the tube we used the efficiency did not rise as high as might be expected, due to the fact that it took excessively high negative potential on the grid to bring the plate current to zero. The oscillograms showed this effect so a static characteristic curve was taken to investigate this point; it is shown in Fig. 163. If Eq. (5) were valid for this tube, a negative potential of 260 volts would have brought the plate current to zero,

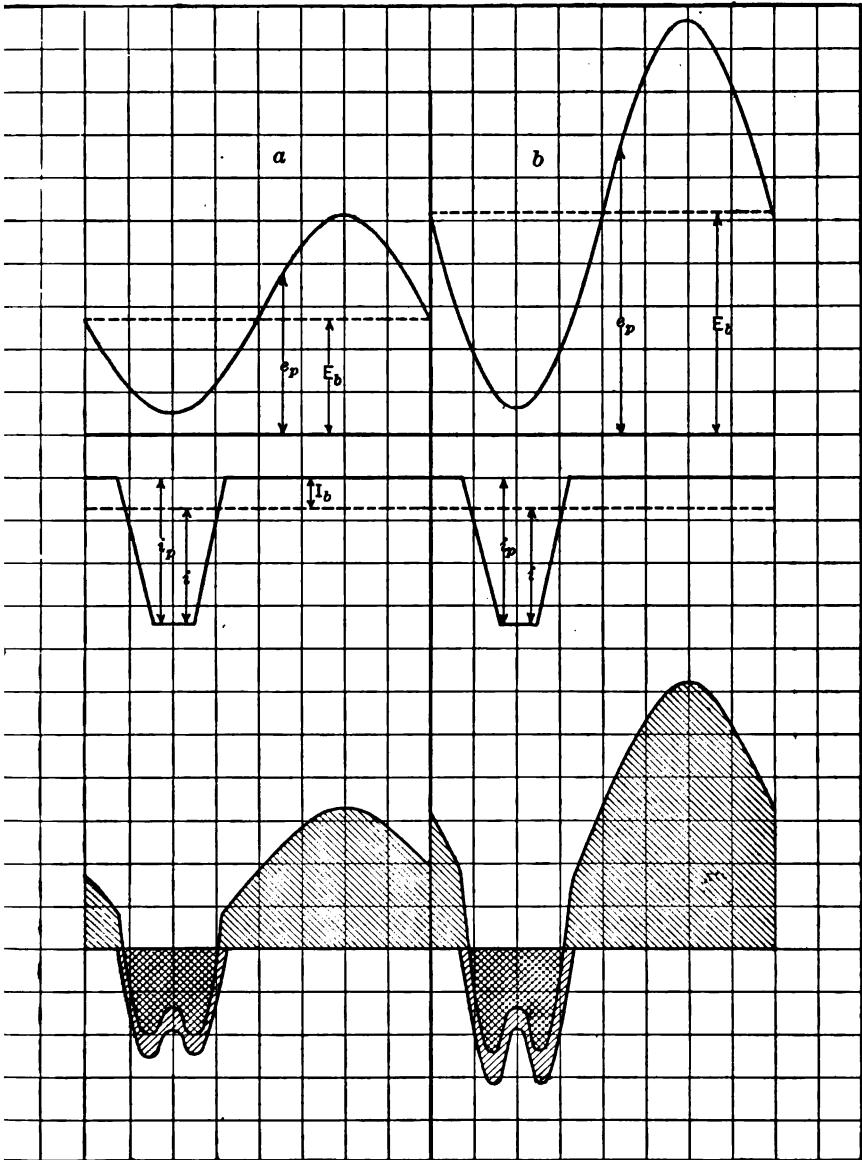

g. 162.— $\int e_p i_p dt = 15$ $\int e_p i dt = 34.5$ $\int e_p i_p dt = 19$ $\int e_p i dt = 71.5$

Efficiency = 70%

Efficiency = 79%

Assuming a fixed form of plate current, and fixed minimum of plate potential, it is seen that the efficiency rises as the voltage used in the plate circuit (E_b) is increased.

whereas it took about 1000 volts; although the plate current is small with a grid negative more than 300 volts this small current has a marked effect on loss of power on the plate, because of the very high plate voltage during that part of the cycle when this small current is flowing to the plate.

Experimental Proof of Foregoing Theory.—To test the validity of the ideas presented above a series of runs were made with the tube, using the circuit given in Fig. 154 and the results therefrom are shown in Table I. The frequency was kept at the resonant value for the output circuit and each time a set of readings was taken the value of R was changed properly to maintain the current in the oscillating circuit constant. This

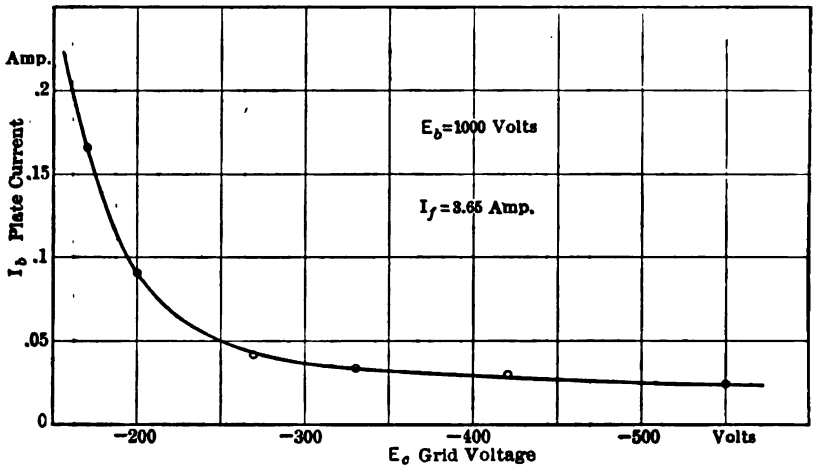

FIG. 163.—The tube used in the tests did not have a constant value for μ_0 ; theoretically a negative potential of 260 volts should have reduced the plate current to zero. This tube would have required about 1000 volts (negative) on the grid to completely cut off the plate current.

was necessary in order to keep the form of the voltage e_p constant as the values of E_c and E_g were varied. While it was not thus pointed out in discussing the current forms of Figs. 161 and 162, the values of E_c and E_g are the factors which bring about the change of current form as the form of e_p is maintained constant. The form of current shown in (a) Fig. 161 was obtained with relatively low E_c and E_g , the value of each of these being increased for the succeeding diagrams of the figure.

In Fig. 164 are shown the efficiency curves for the various runs of Table I and on the curve sheet are given the calculated values of the maximum positive grid potential for that condition in each run which gave maximum efficiency, as indicated at a , b , c , d , etc. For the comparatively low value of current in the oscillating circuit which obtained

TABLE I

$E_b = 1000$ volts. $C_1 = 2\mu F$. $C_2 = 3.91\mu F$. $\omega = 140$. $L_1 = 9.8H$. $I_f = 3.65$ Amp.

Run.	E_c volts.	E_g effective volts.	Input watts.	I_s effective amps.	R ohms.	Output RI_s^2 watts.	$\eta = \frac{\text{Output}}{\text{Input}}$ %	
E	120	220	334	0.98	149	143	42.8	
	150	220	298	1.00	149	149	50.0	
	180	220	214	1.02	119	124	51.5	
	210	220	186	1.00	89	89	47.8	
	250	220	119	0.96	42	39	32.8	
	150	260	302	1.00	149	149	49.3	
	180	260	273	1.03	149	158	58.0	
	210	260	241	0.99	149	140	60.5	
	240	260	197	0.99	119	117	59.5	
	270	260	161	0.96	89	82	51.0	
	150	300	302	1.00	149	149	49.3	
	180	300	283	1.02	149	155	54.8	
	210	300	261	1.02	149	155	60.0	
	240	300	246	1.00	149	149	60.8	
	270	300	212	0.98	134	129	60.8	
A	180	340	291	1.01	149	152	52.3	
	210	340	278	1.03	149	158	56.8	
	240	340	265	1.04	149	161	60.8	
	270	340	244	1.01	149	152	62.4	
B	300	340	229	0.99	149	146	63.8	
	330	340	186	0.99	119	117	63.0	
	270	400	260	1.02	149	155	59.7	
	300	400	250	1.03	149	158	66.3	
	330	400	235	1.02	149	155	66.0	
	360	400	222	1.00	149	149	67.3	
	390	400	197	0.96	134	124	63.0	
	420	400	150	1.02	89	93	61.8	
	C	450	400	128	0.98	74	71	56.3
		410	460	228	1.02	149	155	68.0
D	420	500	245	1.05	149	164	67.0	
	450	500	237	1.04	149	161	68.0	
	480	500	222	1.01	149	152	68.6	
	510	500	195	1.04	119	129	66.2	
	540	500	176	1.02	104	108	61.5	
	570	500	157	1.04	89	96	61.2	

during these tests the form of plate voltage is somewhat different from a sine wave, and the variation of best grid potential may have been due to this cause. The increase in efficiency with increase of E_p and E_c is as would be expected from the analysis given for Fig. 161.

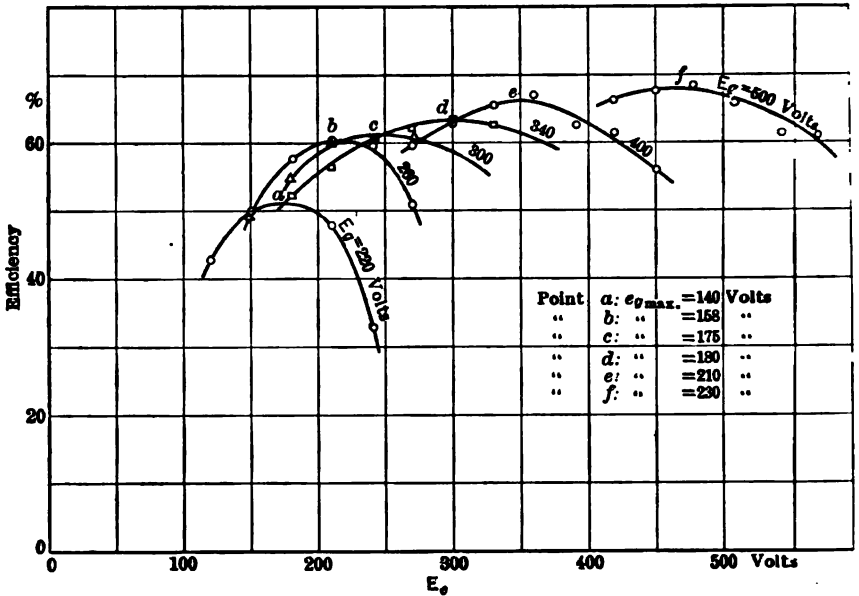

FIG. 164.—Efficiency curves plotted from Table I; the values of positive grid potential for maximum efficiency in each run is calculated and recorded. This agrees well with the predicted "best grid potential."

A series of runs was then carried out (results given in Table II) to study the effect of varying the value of the minimum plate voltage, other conditions remaining the same; this was accomplished by varying R , thus cutting down the value of the oscillating current and hence the variation of voltage across the condenser C_1 , Fig. 154. The variation of potential

TABLE II

$E_b = 1000$ volts. $C_1 = 2\mu F$. $C_2 = 3.91\mu F$. $\omega = 138$. $L_1 = 9.8H$. $I_f = 3.65$ Amp.

Run.	e_p min. volts.	E_c volts.	E_g effective volts.	Input watts.	I_1 effective amps.	R ohms.	Output = Ri_1^2 watts.	$\eta = \frac{\text{Output}}{\text{Input}}$ %
A	30	270	300	134	1.12	37	46.5	34.7
	100	270	300	179	1.10	85	103	57.5
	160	270	300	204	1.02	117	122	59.8
	250	270	300	217	0.91	149	123	56.8
B	490	270	300	255	0.60	297	107	42.0

across this condenser, it will be noticed, is what controls the fluctuation of plate voltage.

The value of minimum plate voltage can be calculated by subtracting from E_b the resistance drop through L_1 (which was very small for most of our tests) and from this subtracting the maximum value of the alternating potential drop across C_1 . These calculations were made and the results are shown in the curve of Fig. 165; the results verify, better than might be expected, the conclusions reached from theory. With the exception of the first value of e_p (min.) the calculated values agreed with the values measured from the films; the value of 30 was obtained by measurement of the film, the calculated value not agreeing very well.

For various of the runs given in Table I oscillograms were taken; for the conditions of run A the curves of e_p , e_g , and i_p are given in Fig. 166. From this film, as for the succeeding ones, the first thing to be noticed

is that the grid voltage and plate voltage are just 180° out of phase, showing that the load circuit was resistive only. The maximum positive potential of the grid measures on the film 296 volts and the corresponding value of plate potential measures 220 volts. By reference to the curves of Fig. 159 it may be seen that for these respective voltages a large part of the electron current is drawn to the grid, resulting in the peculiar double humped curve of plate current. The maximum negative grid potential was 650 volts, but even this was not sufficient to make the plate current zero. Its values follow, as exactly can be measured, the values given by the curve of Fig. 163.

For run B a set of oscillograms was taken to show all of the quantities involved in the operation of the tube; it required five oscillograph records to get all the quantities wanted. These five films were combined to make

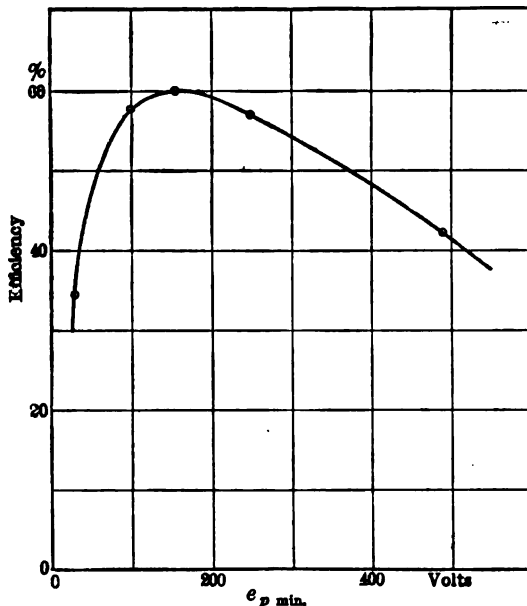

FIG. 165.—From the results given in Table II the efficiency curve shows that maximum efficiency occurs for minimum plate potential of 160 volts the proper value predicted from Fig. 159.

the record shown in Fig. 167; in fitting the various films together care was taken to see that they had their proper respective phases. The white line drawn vertically through all the records gives a line of equi-phase.

This set of curves gives the complete story of the circuit and tube. The plate current is very nearly the form shown in Fig. 162, and the plate potential is nearly of the form shown in condition (a) of the same figure. The slight depression in the peak value i_p is due to the grid taking some current, this depression coinciding in time with the peak of grid current. The form of the positive alternation of the i curve is not like those pre-

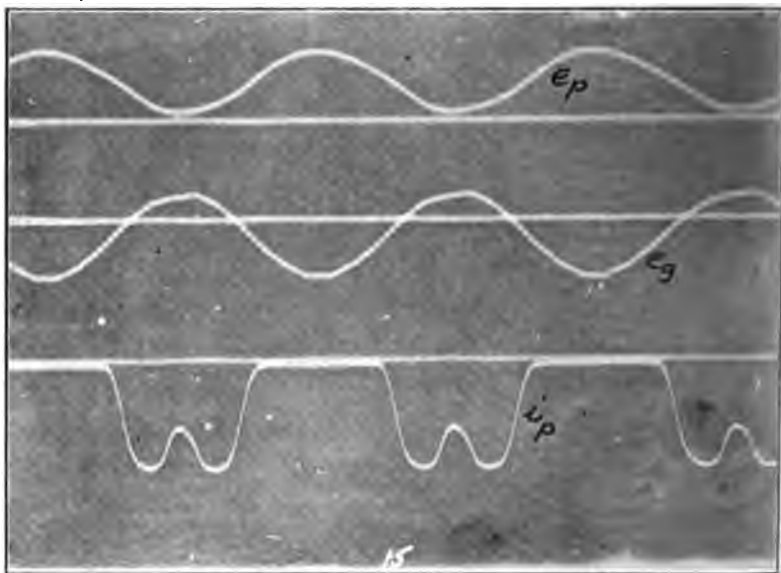

FIG. 166.—Oscillogram for conditions of Run A—Table I; evidently the minimum plate potential is too low.

viously given, due to the fact that it has been assumed that I_b was constant whereas it actually had considerable fluctuation, as shown in the record. If the coil used for L_1 had more inductance this variation in I_b would be diminished; we had only 10 henries with a resistance of 189 ohms, the coil being air core. In practice an iron core coil of greater inductance would be used, but we did not want to introduce any other sources of distortion than the tube itself.

The form of current in condenser C_1 differs from that in condenser C_2 because of the effect of i which will practically all flow through C_1 for the circuit as arranged.

The grid current has just the form and magnitude predictable from

Fig. 159; the amount of current taken by the grid in this test and the values of E_p and E_c used caused a loss of power on the grid (due to bombardment) of about 10 watts.

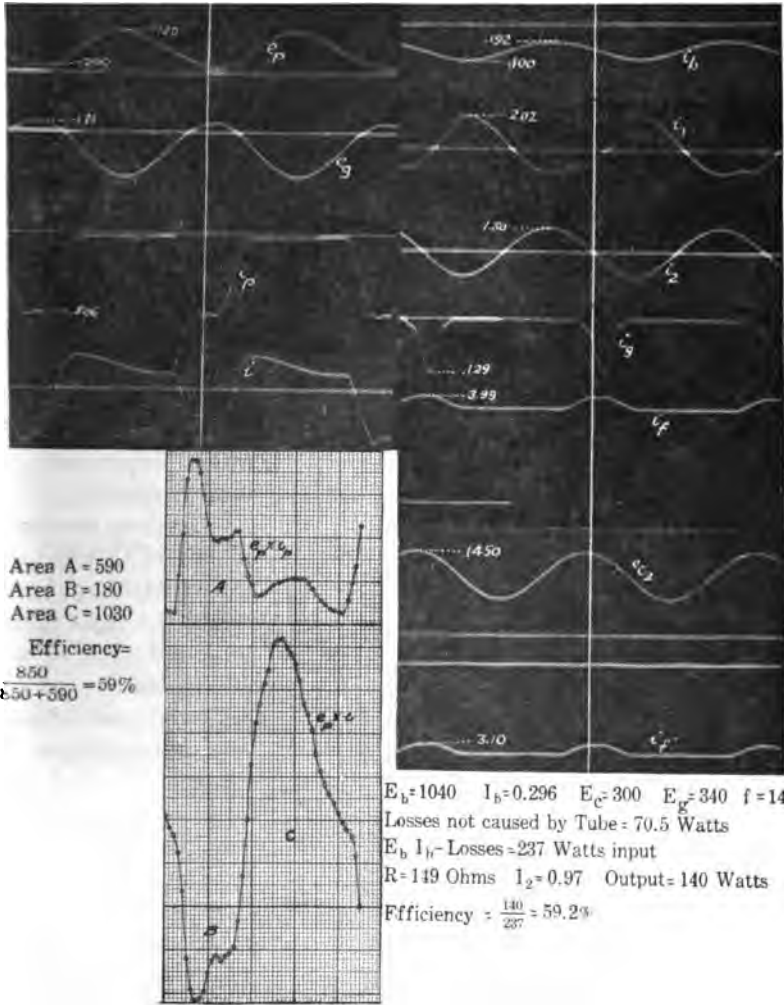

FIG. 167.—Oscillogram of all the currents and voltages for Run B—Table I; the white line represents the same phase on all films. The calculated efficiency from the $e_p i_p$ and $e_p i$ areas agrees well with the calculated efficiency.

The two filament currents, i_f and i'_f , have forms which might be predicted from curves similar to those given in Fig. 157; in that end of the filament carrying the larger current the continuous current ammeter measuring the current indicated only 3.65 amperes, whereas the current

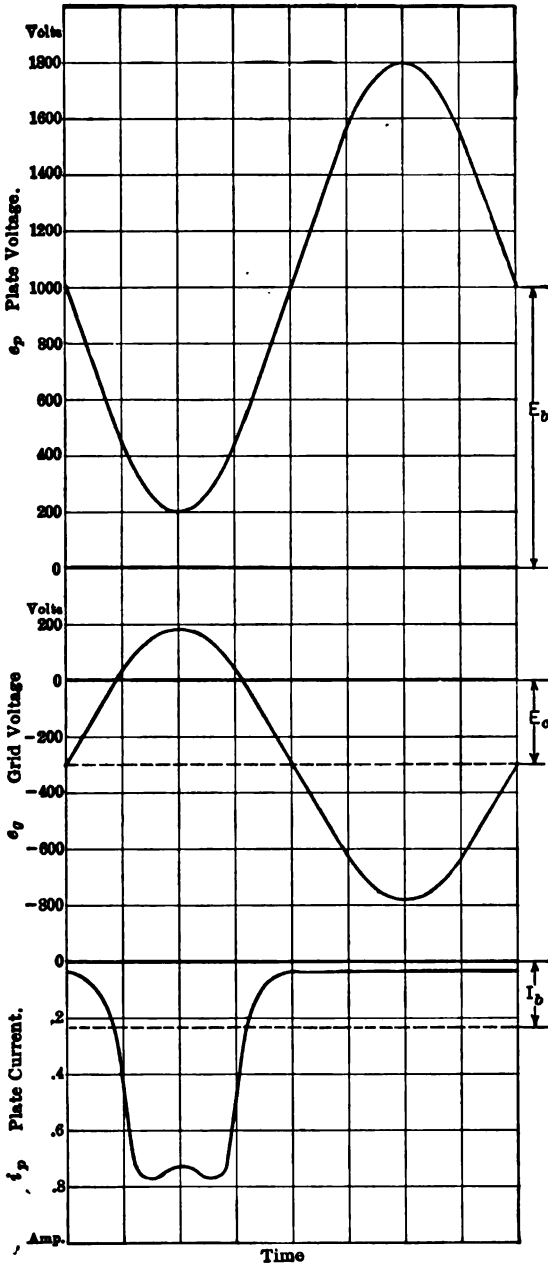

FIG. 168.—Form of plate current curve predicted from Fig. 159; it agrees well with the form actually obtained in Fig. 167.

actually went as high as 3.99 amperes when the plate was taking its maximum current. The exact amount of emission from the filament when the tube is acting as a generator cannot be predicted from the static characteristic; the temperature distribution in the filament which exists in the oscillating condition of the tube cannot be duplicated in a static test, and it is this temperature distribution which determines the total emission.

The drop across the condenser C_2 was taken to see whether or not it had the right magnitude and phase to serve for excitation of the grid when the tube was run self-exciting; the value of C_2 had been adjusted with this point in mind.

The scheme of getting the efficiency indicated in Figs. 161 and 162 was tried on this record of e_p , i_p , and i , the power curves of $e_p i_p$ and $e_p i$ being shown in Fig. 167; the value obtained, 59 per cent, agrees within the precision of the test with that measured by the

meters in the test. The value of 63.8 per cent given in Table I was the value obtained when the oscillograph circuits were not connected, the closing of the circuits changed the conditions enough to drop the efficiency to 59.5 per cent.

Fig. 168 shows the form of i_p , which is predicted from Fig. 159 after the forms and magnitudes of e_p and e_g have been assumed; this form of i_p is very close to the actual form given in the oscillogram of Fig. 167.

The result of our tests and analysis have then shown that the efficiency of a tube as a converter can be accurately predicted from the three sets of curves given in Figs. 156, 159, and 163 after we have determined, from the curves of Fig. 159, what the best minimum plate potential is and also what the maximum positive potential of the grid should be.

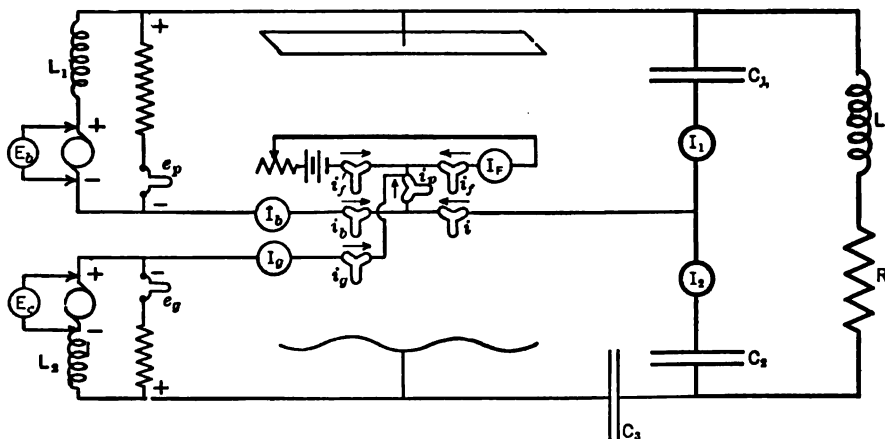

FIG. 169.—Arrangement of the tube circuit for self-excitation; the machine E_c maintains the grid at the proper average potential.

To get a fair efficiency (60 per cent or better) the value of I_b should not be greater than 25 per cent of the saturation current of the tube; with the efficiency known and the safe radiation of power from the plate being known the proper value of E_b is fixed.

Self-excited Tube.—Using the circuit and constants used in getting the records of Fig. 167 an attempt was made to run the tube self-exciting by changing the connections slightly as shown in Fig. 169. The choke coil L_2 serves to prevent the grid from being short-circuited to the filament (for the a.c. excitation) through the machine E_c . The voltage for excitation was obtained from the drop across the condenser C_2 , the insulating condenser C_3 being necessary to prevent short-circuiting the machine E_b . With this connection the grid does not get quite as much excitation as shown by the curve e_c in Fig. 167, because an appreciable part

of this voltage is used in overcoming the reactance drop in C_3 . (In this calculation the capacity of the grid circuit of the tube itself must be considered; in some of the Type P tubes this capacity is as high as 500 μmf , when the load circuit has its proper impedance for maximum output—see p. 442.)

The circuit of Fig. 169 refused to act as it did for the separate excitation, giving a small output at a low efficiency; a more careful examination of the record in Fig. 167 gave the reason. The alternating components of e_g and e_p must be exactly 180° out of phase if the maximum output and efficiency are to obtain, as becomes at once evident if the construction of Fig. 161 be carried out for any other than the 180° relation.

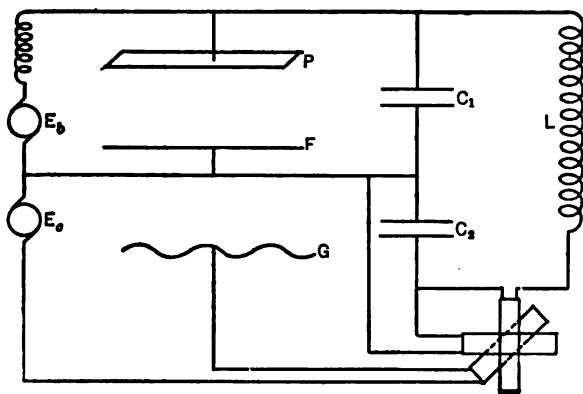

FIG. 170.—A possible arrangement of self-excitation, in which the phase of the voltage impressed on the grid is adjustable.

Measurement of the film of Fig. 167 shows e_c to be 33° out of the 180° phase with e_p and that much phase displacement is sufficient to completely upset the conclusions so far reached. It was therefore necessary to change the relative phase of e_g and e_c . A possible scheme is conventionally indicated in Fig. 170; a rotating field is produced by proper connection to the load circuit and a rotatable coil placed in this rotating field serves for the grid excitation. We had a simpler scheme at hand so did not try this one.

The difference in phase in the voltages across C_1 and C_2 comes from the effect of the current i , present in C_1 to a greater extent than in C_2 . By making the effect of this current small its disturbing effect may be reduced, and this can be done by increasing the values of C_1 and C_2 , and decreasing the value of R , the value of L being properly reduced to maintain the same resonant frequency. The increase in capacity will increase the value of the oscillatory current i_1 , and as i remains constant its effect on the relative phases of e_c and e_g becomes proportionately less as the capacity is increased.

The arrangement of apparatus remaining as in Fig 154, the constants were readjusted for efficient operation and a set of readings were obtained as follows: $E_b = 900$ volts, $E_c = 230$ volts, $E_g = 310$ volts, Frequency = 143.

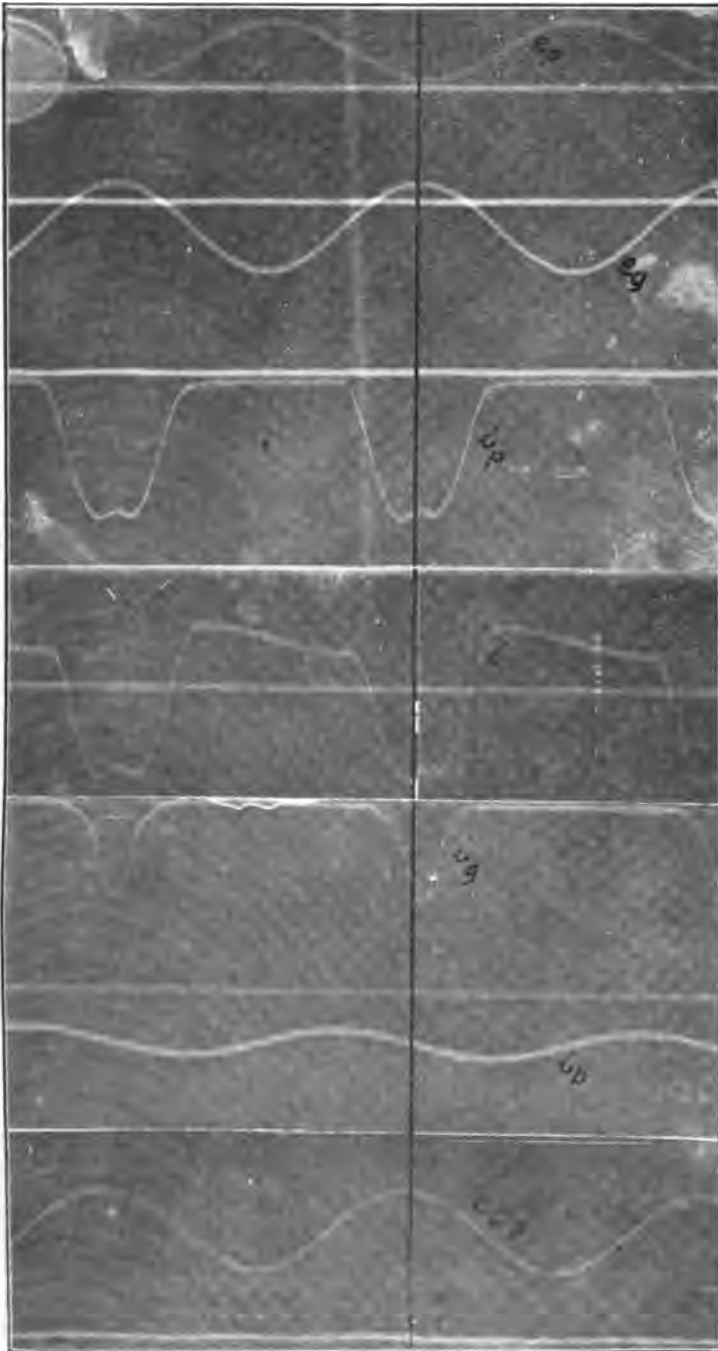

FIG. 171.—Conditions occurring in the self-excited tube; the plate current did not drop to zero as it should do, because there was not enough negative potential on the grid.

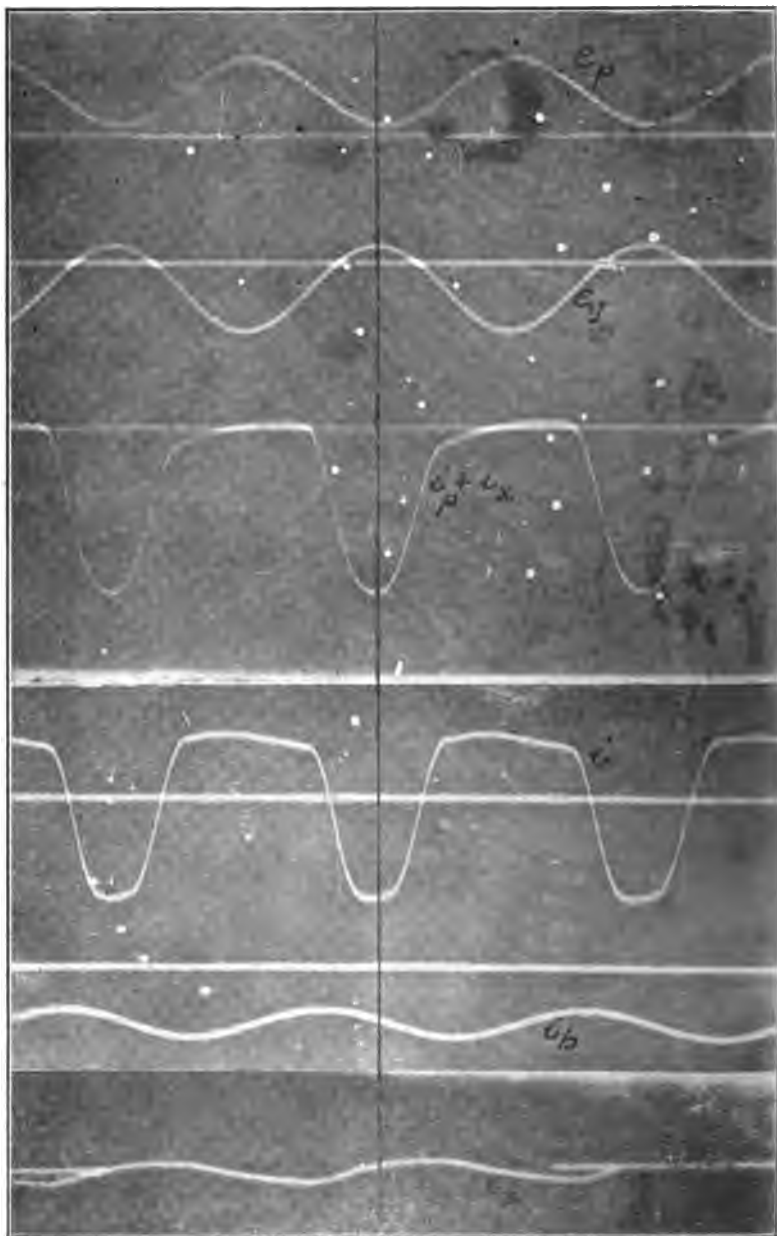

FIG. 172.—In this case of the self-exciting tube the plate voltage did not fall sufficiently low to give best efficiency; it measures on the film 300 volts where as Fig. 165 shows the proper minimum plate potential to be 160 volts.

$L_1 = 9.8$ henries, $I_b = 0.321$ ampere, $C_1 = 9.2$ microfarads, $C_2 = 19.4$ microfarads. The resistance of the load circuit was 7.80 ohms and the oscillatory current produced was 4.30 amperes, giving an alternating current output of 143 watts. The input to the tube circuit is obtained from the product $E_b I_b$, after certain losses, not chargeable to the tube circuit, have been deducted.

The condensers C_1 and C_2 each consisted of two condensers connected in series because of the high potentials occurring in the circuit. In order to make the two individual condensers divide the voltage E_b , equally it is necessary that their insulation resistances be alike, a condition seldom

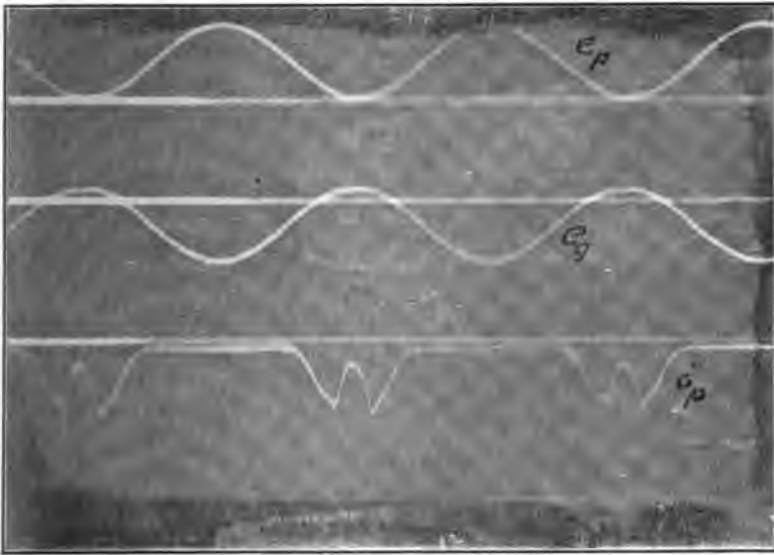

FIG. 173.—Separately excited tube— $E_b = 1040$, $I_b = .170$, $E_c = 270$, $E_o = 300$, $R = 37$.
Input = 106 watts. Output = 50, Efficiency = 47%.

encountered. That condenser having the higher resistance (the better one) will take practically all of the E_b voltage as well as its share of the alternating voltage of the circuit, resulting in its probable breakdown. To prevent this occurrence leak resistances were used across each of the condensers making up C_1 and C_2 , the leaks each being 21,000 ohms, making the leak resistance of C_1 and C_2 each 42,000 ohms. Subtracting the I^2R losses in these leaks as well as the I^2R losses in the choke coil L_1 , gives the input to the tube circuit 229 watts; the efficiency was thus 62.7 per cent.

Oscillograms taken of the currents in this circuit are given in Fig. 171. It is evident that the values of E_o and E_c might well have been greater,

resulting in a higher efficiency because of the resultant smaller minimum plate current. Although the plate current is small the plate voltage is large and so results in a high unnecessary loss on the plate.

The phase of e_c is now practically coincident with that of E_o , and it should therefore serve as a source of excitation. The circuit did not give as much power, however, when made self-exciting, as it should, so the constants were changed slightly to get more power. As finally tested the self-exciting circuit had the constants and performance given herewith: $E_b = 1000$ volts, $I_b = 0.335$ ampere, $C_1 = 7.36$ microfarads, $C_2 = 13.8$ microfarads, $L = 0.201$ henry, $L_1 = 9.8$ henries, $L_2 = 9.0$ henries, $E_c = 230$

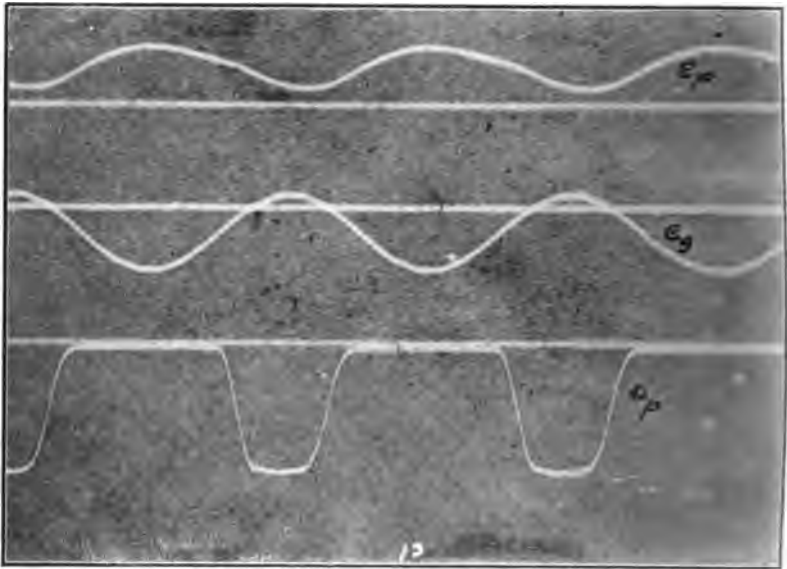

FIG. 174.—Conditions as given in Run B, Table II.

volts, $R = 8.0$ ohms. The current produced in the oscillating circuit was 4.40 amperes, resulting in an efficiency of 57 per cent.

Fig. 172 shows the currents and voltages in this self-exciting circuit, and it is at once evident why such a comparatively low efficiency was obtained; the minimum plate voltage, instead of being 200 volts, as it should for this tube, was 300 volts. For this figure the curve of plate current included also the alternating component of the grid current, hence the absence of the depression at the peak value.

The current through the plate-current vibrator reversed during part of the cycle, due to the fact that this vibrator carried in addition to the plate and grid currents, an alternating current which resulted from the voltage across the condenser C_2 acting through the reactance of coil L_2 and

condenser C_2 , Fig. 169. This current is shown as i_x in Fig. 172; when the plate current is corrected by this small amount it is seen that the plate current does not reverse, as we know it cannot with the conditions as they existed in this test.

Action of the Tube at High Frequency.—It was desired to show that the action of the tube was just the same at high frequency as at the low frequencies used, so a circuit was arranged similar to that of Fig. 169, with smaller values of capacity and inductance. The choke coils L_1 and L_2 used in the previous tests would act as condensers of comparatively low reactance at the high frequency to be used so they also had to be

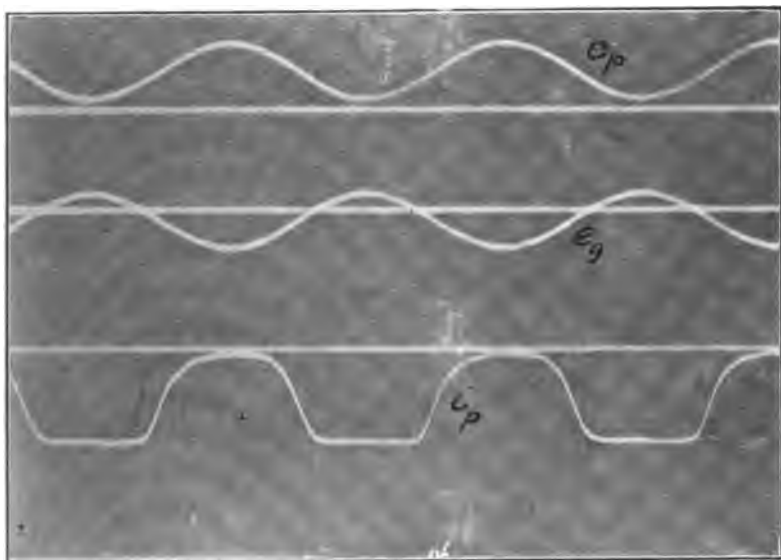

FIG. 175.—Conditions as given in Run E, Table I.

changed. The constants of the circuit used were: $E_b = 1000$ volts, $I_b = 0.285$ ampere, $C_1 = .0144$ farad, $C_2 = .0284$ microfarad, frequency = 98,500, $L_1 = .023$ henry, $L_2 = .016$ henry, $E_c = 240$ volts, $R = 6.16$ ohms (high-frequency determination). There were no leaks used with the condensers in this circuit, so that the product $E_b I_b$, after subtracting the $I^2 R$ loss on the choke coil L_1 , gives the input. It is found to be 284 watts, and as the output to the load circuit was 160 watts the efficiency was 56.2 per cent, which is in fair agreement with the results obtained at 166 cycles.

Figs. 173–177 are shown some special oscillograms of the plate current, plate voltage, and grid voltage, all for the separately excited tube with the circuit shown in Fig. 154; the conditions of the circuit were as noted in Tables I and II.

The conditions obtaining when Fig. 177 was taken show the best adjustments for efficiency which we were able to get with the Type P tube; the high efficiency was obtained without unduly decreasing the output. If this form of plate current could be maintained and the value of E_b be increased to 3000 volts the calculated efficiency becomes 85 per cent; this is probably as good as could be done with sine wave shapes of e_p and e_g , but it seems as though, by suitably deforming both of them, giving them both flat tops, the efficiency could be considerably increased over this value.

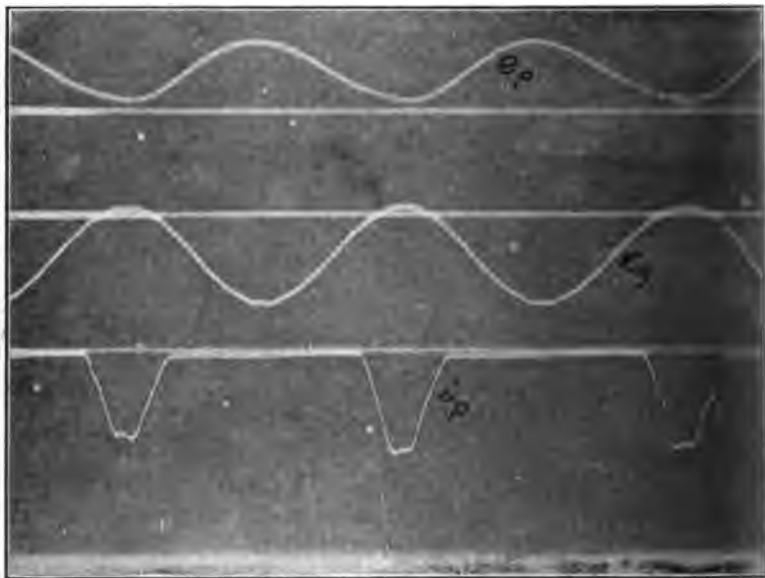

FIG. 176.—Conditions as given in Run C, Table I.

Tests similar to those described in this paper were carried out using a much smaller tube, that styled by the U. S. A. Signal Corps type VT-2. The results obtained with the large tube were duplicated almost exactly in so far as efficiency was concerned. It was found possible to so adjust the values of E_c and E_g that the tube gave an output of 6.3 watts with an efficiency of 70 per cent, the voltage used in the plate circuit being the rated value, namely 300 volts. It was found possible to get over 7 watts output with the plate loss considerably lower than its safe rated value; if the plate voltage had been increased to perhaps 400 volts the tube output might have been raised to 10 watts while still having the plate loss within its safe value.

These tests were all carried out with a separately excited tube; with

the tube self-excited the efficiency was not obtained higher than 61 per cent, with a plate voltage of 300. This run gave an output of 5.6 watts output with a current I_b of 0.305 ampere; the frequency was 400,000 cycles, the value of R was 53 ohms, the oscillating current 0.325 ampere, C_1 and C_2 being 1360 and 770 micro-micro-farads, respectively. The value of E_c was 40 volts.

With the conditions of a self-excited circuit adjusted for the best conditions as previously outlined difficulty may be encountered in starting the circuit to oscillate, a shock of some kind being generally required to start oscillations. Because of this possible difficulty it may be the best

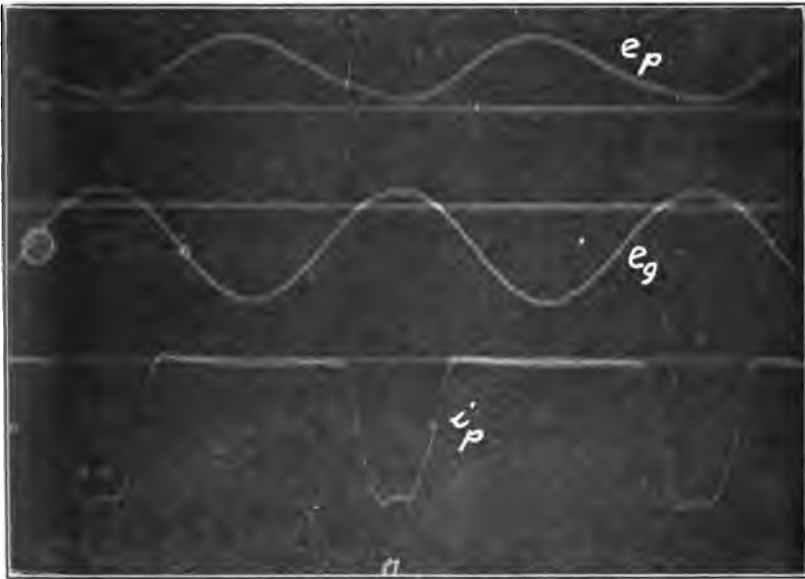

FIG. 177.—Best conditions for high efficiency. $E_b = 1040$, $I_b = .286$, $E_c = 410$, $E_g = 460$, $R = 149$, Input = 227 watts, Output = 155, Efficiency = 68%.

practice to run these tubes separately excited, using one tube (so adjusted that it oscillates readily) for exciting others as indicated in Figs. 140–141, pp. 533–534. It may well be that with a higher resistance in the oscillating circuit more output can be obtained from two tubes if one only is used as a generator, the other being used as exciter only. Certainly if more than two tubes are to be used it will be well to use one as exciter for supplying the grid voltage for the others.

Characteristics of the Circuit of Fig. 122.—Using the circuit shown in Fig. 122, a series of runs was made to investigate the effect of changing the constants of the circuit and some of the results are shown in Figs. 178

and 179; the legends and diagrams on the curve sheets make them self-explanatory. For these tests three plitrons (type P-30) were operated in parallel, all grids being connected together as also were the plates; the plate current recorded on the curve sheets is that of one tube.

It may be seen, from Fig. 178, curve 3, for example, that for efficient coils and condensers of the type used here it is possible to get as much as 16,000 volt amperes from one tube, with only 800 volts on the plate and normal filament current. The behavior of the tubes, as regards

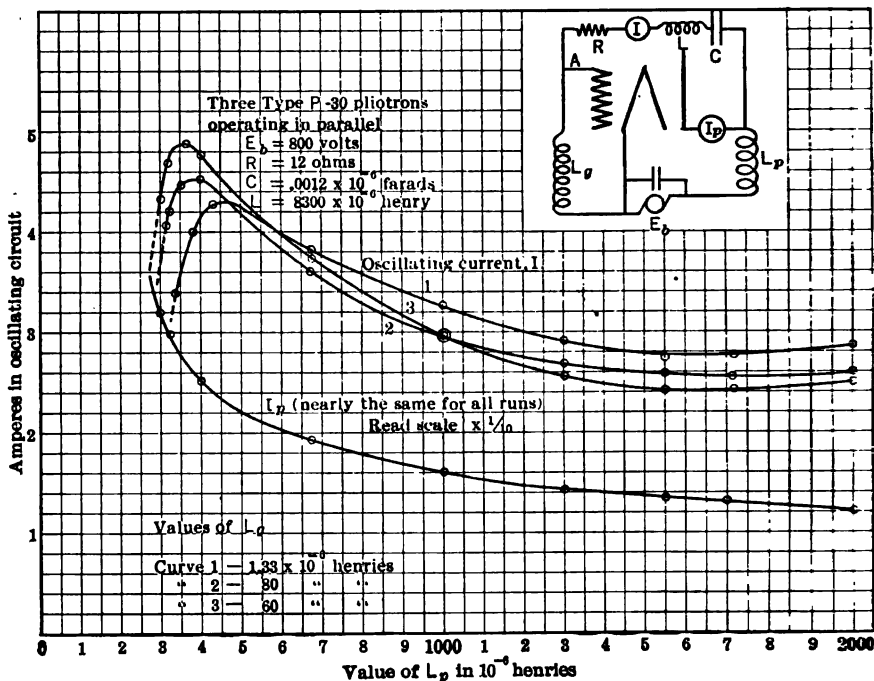

FIG. 178.—Amount of high-frequency power obtainable from three Type P plitrons in parallel and effect of changes in L_p .

stability, conditions for maximum output, etc., agree fairly well with the theoretical predictions.

Characteristics of the Three-electrode Tube as an Amplifier.—As the voltage impressed on the input circuit of a tube causes a change in the plate current which may be flowing through an inductance or resistance in the external plate circuit, and as it is evident that the drop across this external circuit may be many times greater than the e.m.f. impressed on the grid, the device may be used as a voltage amplifier. The amplified voltage in the output circuit will have very nearly the same form as the input voltage, sufficiently so that the currents due to speech may be

amplified many times (1000–10,000) and the reproduction of the voice be almost perfect. The circuits used in amplifiers and arrangement of apparatus are taken up in a later chapter; in this section we shall consider only the amplifying characteristics of the tube itself.

As noted before a voltage of $E_{m\theta} \sin \omega t$ introduced in the input circuit of a tube is equivalent to a voltage of $\mu_0 E_{m\theta} \sin \omega t$ introduced into the plate circuit, this voltage causes an alternating current to flow in the plate circuit, the magnitude and phase of which depend upon the external impe-

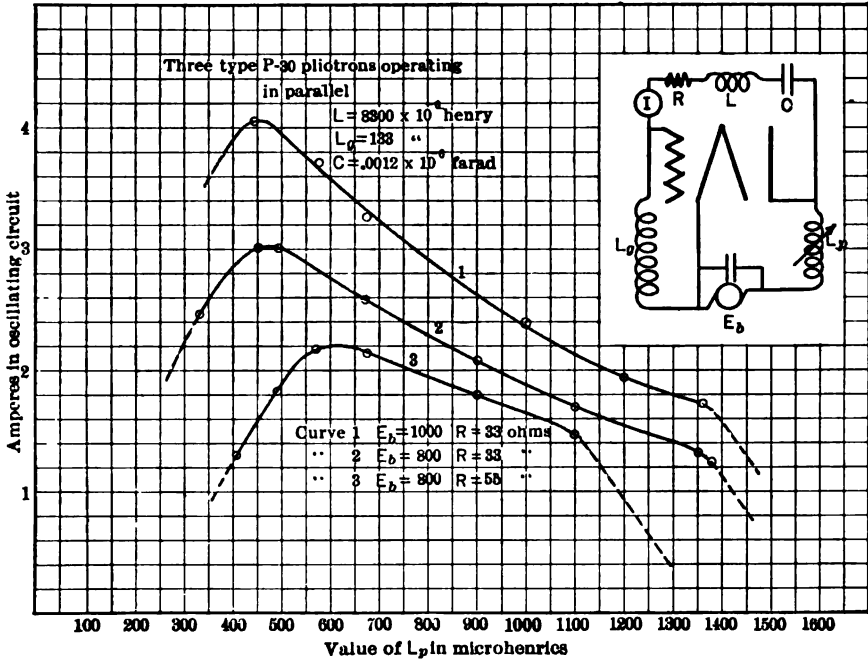

FIG. 179.—Showing the effect of varying the plate-circuit inductance with fixed value of L_p . Region of oscillation indicated by solid lines; outside these limits tubes refused to oscillate.

dance in the plate circuit and the resistance of the tube itself. If we call the alternating component of the plate current I_p , we have the relation,

$$I_p = \frac{\mu_0 E_\theta}{R_p + R} \quad \dots \dots \dots (105)$$

in which R is the external resistance of the plate circuit. The drop across R (which is the only available part of the amplified voltage, the rest being used up inside the tube itself) is $I_p R$ and this is evidently given by

$$I_p R = E_p = E_\theta \mu_0 \frac{R}{R_p + R}$$

From this we get the actual voltage amplification due to the tube, which is designated as μ ,

$$\mu = \mu_0 \frac{R}{R_p + R} \dots \dots \dots (106)$$

This factor μ will be constant (independent of the magnitude of the input voltage E_g) only for such value of E_g as give constant R_p . This can be seen at once from the static characteristic of a tube, showing the relation between plate current and grid potential, this curve to be taken with the proper value of R in the plate circuit; throughout that part of this curve which gives uniform slope the factor μ is constant and the ampli-

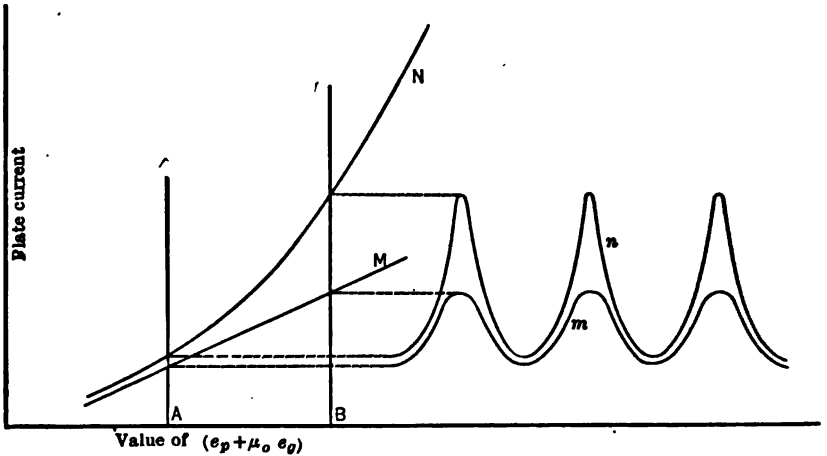

FIG. 180.—Two tubes having different plate-current characteristics as indicated in M and H will give amplified currents having more or less distortion, N giving more distortion than M .

fication is *distortionless*, a very necessary feature of an amplifier used for speech amplification, but of little importance for ordinary signal amplification.

This point is indicated in Fig. 180; two different tubes (or different arrangements of the same tube) might have characteristics as shown at M and N and the form of the plate current produced for a sine wave of voltage impressed on the grid as shown by curves m and n in the same figure. With curve N the value of $\frac{dI_p}{dE_g}$ is greater the more positive the grid becomes, resulting in a lower R_p ; from Eq. (106) it may be seen that for a given value of R the factor μ becomes greater the smaller R_p . A sine wave of voltage impressed on the grid, therefore does not produce a sine

wave of current in the plate circuit and so will not produce a sine wave of voltage across a resistance in the plate circuit.

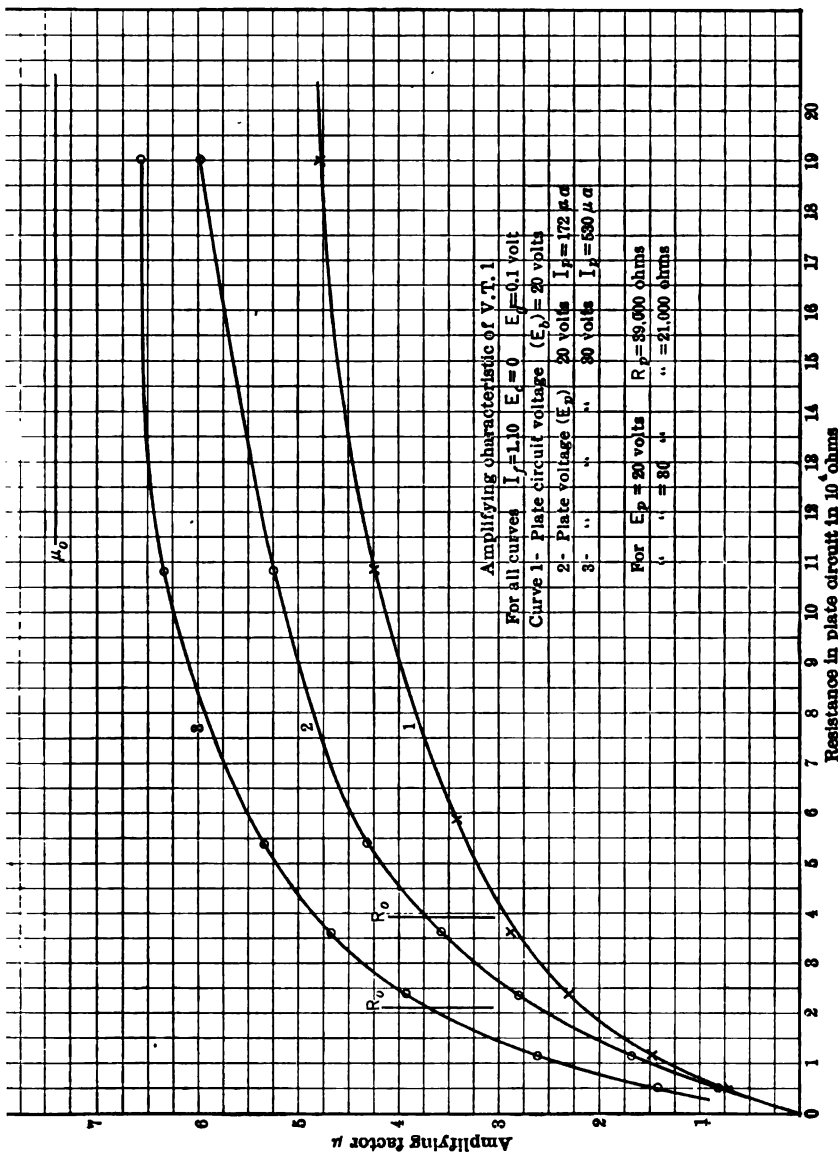

Fig. 181.—Amplifying power of the VT1 tube; for curve 1 the plate voltage was allowed to fall, E_b being constant at 20 volts; for curves 2 and 3 the value of E_b was variable and so adjusted to give a plate voltage of 20 or 30 for all values of external resistance in series with the plate circuit.

From Eq. (106) it is evident that if the amplifying power of a tube is to be efficiently used the value of R must be at least as large as R_p and should really be much larger. In Fig. 181 is shown the measured ampli-

fication constant of the Signal Corps VT-1 tube taken under various conditions. It is seen that the factor μ increases as R increases, for all conditions.

Curve 1 was taken with a constant "B" battery voltage; under this condition the plate voltage decreased as R was increased due to the resistance drop in R . But a decreased plate voltage resulted in an increase in R_p , so that for this condition as R was increased, it approached R_p very slowly due to the increase in R_p with increase in R .

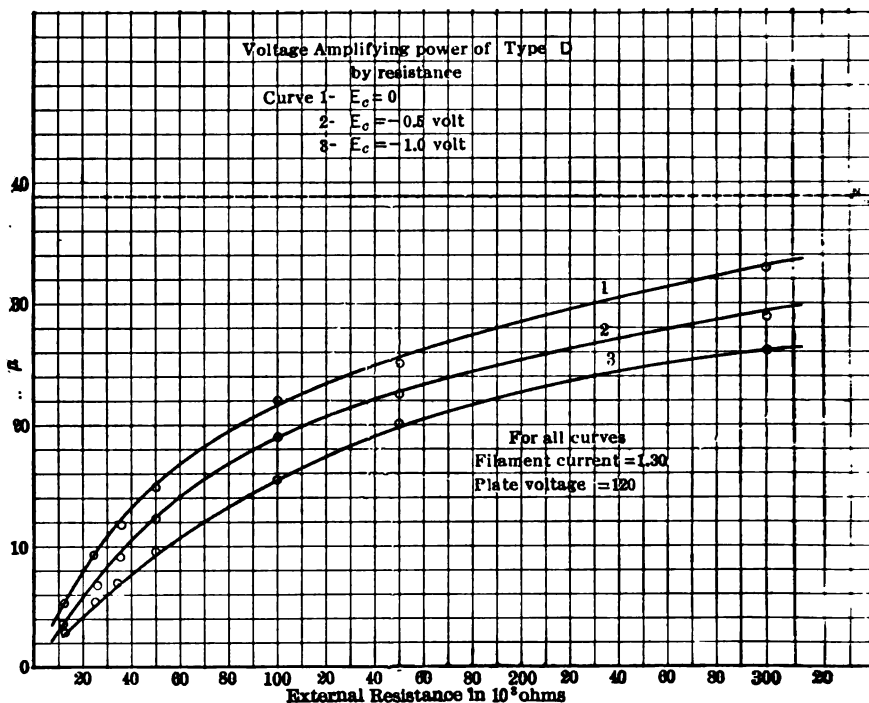

FIG. 182.—Showing effect on the amplifying power of a tube of holding the grid at different average potentials, making the grid more negative increases the tube resistance, hence requiring a higher external resistance to get the same amount of amplification.

Curve 2, compared to curve 1, shows the effect on μ of increasing the "B" battery voltage sufficiently to compensate for the IR drop in the plate circuit, thus maintaining the plate voltage constant; it is seen that the increase of μ with R is much more rapid. Curve 3 shows the effect of maintaining the plate potential at 30 volts instead of 20 volts. The alternating-current resistance of the plate circuit of the tube R_p was measured for curves 2 and 3 and is indicated in the curves; it is seen for each of them that when $R = R_p$, $\mu = \frac{1}{2}\mu_0$ as it should from Eq. (106).

In using a tube as an amplifier it is customary to maintain the grid at such a negative potential that, for any probable input voltage, the grid will not become positive; maintaining a negative grid increases the value of R_p , so that for a given R , μ is decreased. This effect is shown in Fig. 182, which gives the behavior of a tube having a higher value of μ_0 than

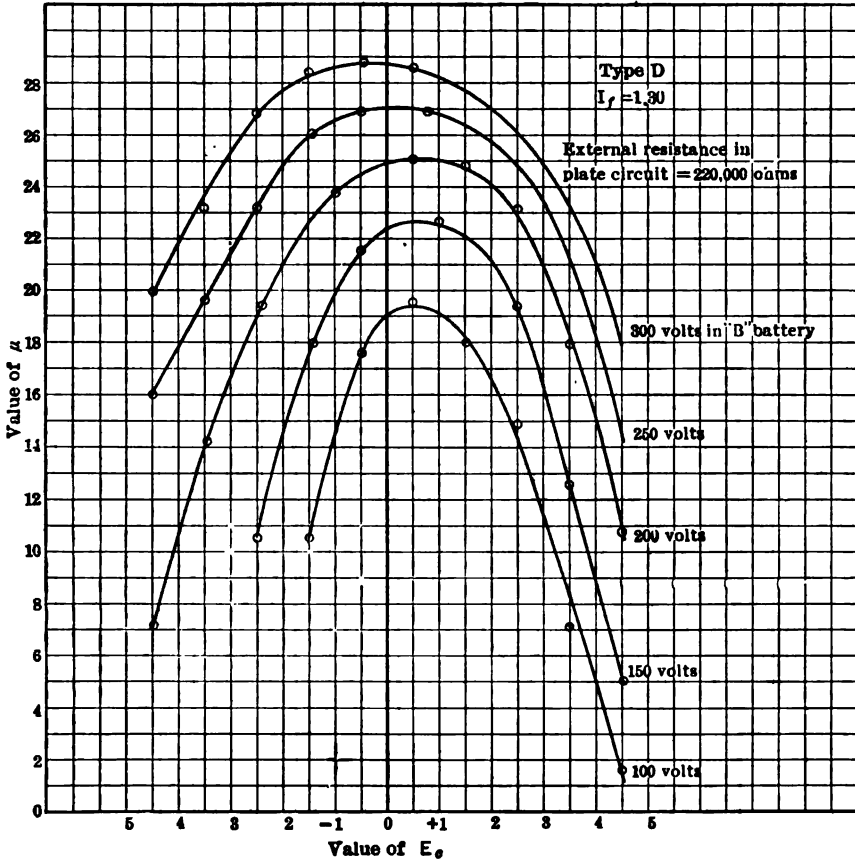

FIG. 183.—Variation in amplifying power with different grid potentials and different plate circuit voltages.

is customary. Fig 183 shows the variation of the amplification factor as both plate circuit voltage, E_b , and grid potential, E_c , were varied. It is evident that this tube could be used effectively for only small values of input voltage.

If the plate current of a tube is expressed by the relation,

$$i_p = A \{ E_p + \mu_0 (E_c + E_{mg} \sin \omega t) \}^2$$

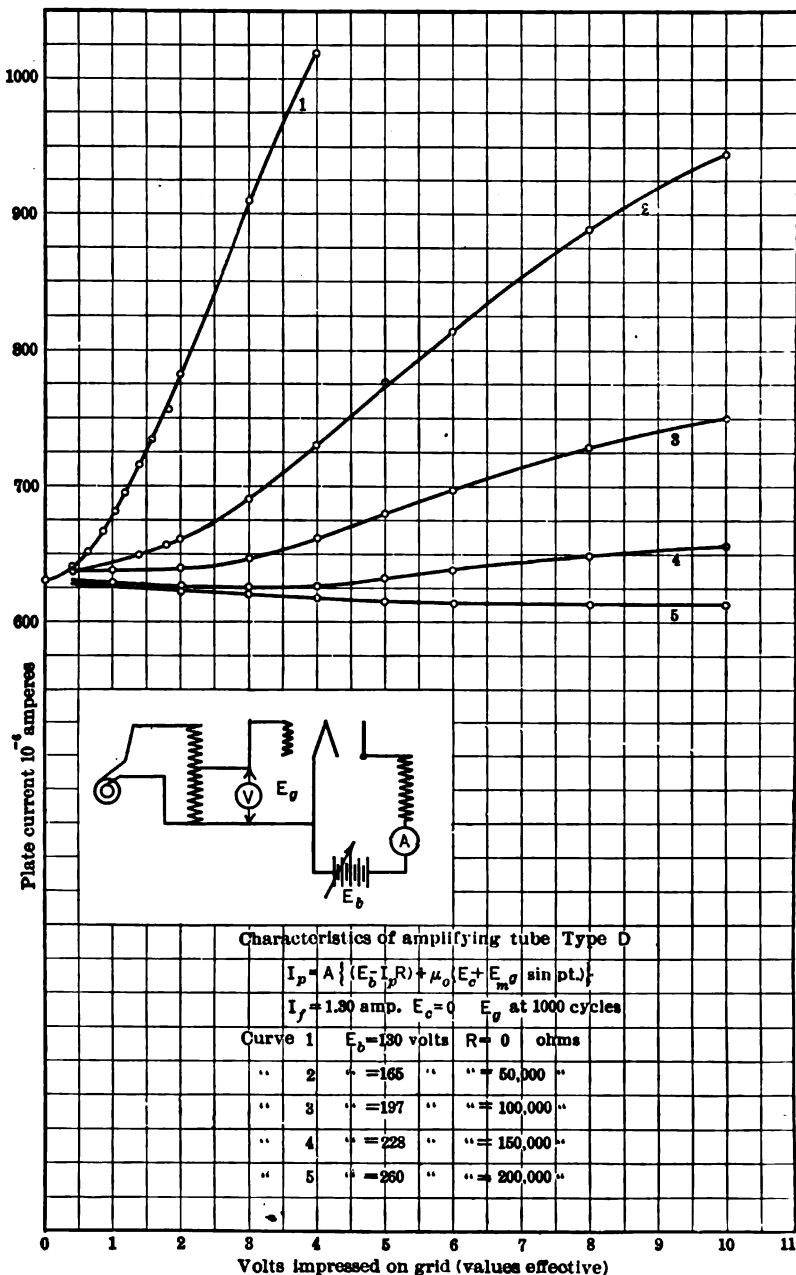

FIG. 184.—The quality of amplification (distortionless or not) is shown by a test of this kind. The tube used requires an external resistance in series with the plate of at least 150,000 ohms to give distortionless amplification.

we get after expansion,

$$i_p = A(E_p + \mu_0 E_c)^2 + 2A\mu_0(E_p + \mu_0 E_c)E_{m_0} \sin \omega t \\ + \mu_0^2 \frac{A E_{m_0}^2}{2} \cos (2\omega t + \pi) + \frac{\mu_0^2 A E_{m_0}^2}{2}.$$

The first term gives the steady value of plate current with no input voltage, the second the true amplification current, the third a double-frequency distortion current, and the fourth a steady increase in the value of i_p , while $E_{m_0} \sin \omega t$ is acting. The third term has the same coefficient as the fourth and the fourth term will register on a direct current ammeter in the plate circuit. Hence the quality of amplification of a tube (distortionless or not) may be judged by the indication of the plate ammeter as the input voltage is impressed. Fig. 184 shows this effect and also the effect of added resistance in the plate circuit in decreasing the distortion. With 150,000 ohms added in the plate circuit, this tube would give essentially distortionless amplification for input voltage as high as 5 volts.

In case a reactance is used in the plate circuit, for repeating, instead of resistance, it will be found that the value of μ is greater than for a corresponding value of resistance. Thus if an inductive reactance (of negligible resistance) is used in the plate circuit, the value of the reactance being equal to the tube resistance, a value of μ is obtained equal to $0.7 \mu_0$ instead of $0.5 \mu_0$ as was obtained for resistance. This follows at once by considering the voltage relations in a tube circuit, as given in Fig. 96, p. 475.

CHAPTER VII

CONTINUOUS-WAVE TELEGRAPHY

Advantage of Continuous-wave Telegraphy.—Continuous-wave telegraphy possesses several distinct advantages over damped-wave systems which may be summarized as follows:

1. *Greater Selectivity.*—This advantage is due primarily to the fact that energy radiated by a spark transmitter is sent out in damped-wave trains. These wave-trains, striking the receiving antenna, induce therein an electromotive force, and if the circuit is tuned to the incoming wave, maximum current and signal strength are obtained. However, even if the circuit is somewhat de-tuned, the damped-wave train will excite the circuit to a considerable extent, causing it to oscillate at its own frequency, as well as at the frequency of the signal wave.¹ In other words the selectivity of reception of a spark signal is fixed, not only by the decrement of the receiving circuit, but also by the decrement of the wave-train itself, which, of course, is that of the transmitting station; thus more or less interference always exists between spark stations, if the wave-lengths are close to one another.

If we consider the effect of continuous waves at the receiving station, the conditions will be somewhat different. The incoming energy forces the receiving circuit to oscillate at its own signal frequency, except at the beginning, when the forced and natural oscillations are coexistent for a few cycles. Therefore if this circuit is not tuned to resonance with the incoming signal and does not possess abnormal resistance values (which would flatten out its resonance curve), the current flowing will be very small and the signal strength extremely weak, under all conditions of adjustment except that of resonance. Thus the selectivity is good, and the station will receive no messages except those for which it is tuned.

2. *Increased Range of Transmission.*—This follows from the fact that with continuous-wave transmission, the energy is radiated at and concentrated into, essentially one wave-length, instead of being spread over a number of wave-lengths, as indicated by the energy distribution curves discussed in Chapter V, p. 326. The greater the amount of energy we can thus concentrate into one wave-length, the further will be the distance penetration or propagation of this energy, and stations may be

¹ See Chapter IV, p. 268.

reached at much greater distances from the sending station than with the spark transmitter.¹ Also, for the same range, less power is required than with the spark transmitter, and the transmission efficiency thus improved.

3. *Antenna Voltages Decreased.*—Since the energy is radiated in a continuous stream, when a signal is being sent, and not in groups, it follows that for a given power in the antenna the amplitude of the oscillations need not be so great. For example, if we assume 1000 sparks per second, a decrement of .1, and a 300-meter wave, the time per second during which energy is radiated² is:

$$1000 \times \frac{4.6}{.1} \times 10^{-6} = .046 \text{ second}$$

= 4.6 per cent of the total time;

whereas with continuous-wave transmission the time would be 100 per cent. It is therefore obvious that if much power is to be radiated by the damped wave-transmitter, comparatively high oscillation amplitudes must be used, that is, the energy associated with a group of waves, for a given amount of energy radiated per second, must be high, since energy is radiated only during a small fraction of the time. Thus a given antenna will have a greater possible energy radiation on continuous waves, since the energy may be radiated continuously; an advantage of thus decreasing the required amplitude of oscillation for a given radiation is the reduction in required voltage, thus decreasing the construction difficulties encountered in extremely high-voltage apparatus and antennæ (due to corona losses, insulation requirements, etc.).

4. *Adjustment of Signal Note.*—With damped wave-transmission this characteristic is a fixed quantity which cannot be adjusted by the receiving operator, and is determined entirely by the transmitter group frequency. With the undamped-wave receivers described below, this can be varied, over wide limits, to a value most suitable to the operator for distinguishing from strays. The adjustability of the note of the received signal also serves to a remarkable degree to eliminate interference from other stations; because of this feature another signal, differing in frequency from the true signal by perhaps 1 per cent, is actually inaudible.

Summary.—The above advantages combine to give to a continuous-wave transmitter a wonderful degree of selectivity and efficiency of trans-

¹ The statement is true primarily because of the greater sensibility of the receiving circuit adjusted for continuous-wave reception. The attenuation which occurs as a wave travels over the surface of the earth is probably the same for continuous, as for damped, waves.

² On the assumption that radiation ceases when the current in the antenna has dropped to 1 per cent of its original value.

mission, very much higher than could be obtained with the damped-wave type. In addition may be mentioned the very important part which continuous waves have played in the development of radio telephony (see Chapter VIII), for which it is essential. Because of these advantages, it is probable that continuous-wave telegraphy will ultimately supersede and replace entirely the damped-wave systems; in the large stations, this change already has been made or is being made at the present time.

High-frequency Undamped-wave Generators.—Continuous high-frequency oscillations may be produced by any one of the several schemes described below. All of these have been commercially developed and applied, and are listed in the order of their importance (this relative rating being for high-power stations only) at the present date (1920). It is probable that the first three means of generation will find increasing development in the future, while the fourth and fifth will be superseded by one form of the first three methods. The development and importance of vacuum tubes as generators of high-frequency oscillations has been very rapid within recent years, and it is likely that this source of high-frequency power will ultimately replace all others.

The several means of high-frequency power generation are as follows:

- (1) Poulsen Arc;
- (2) Alexanderson Alternator;
- (3) Goldschmidt Alternator;
- (4) Iron in saturated cores;
- (5) Marconi Series of Spark Gaps;
- (6) Oscillating Tubes.

Poulsen Arc.—A great deal of work has recently been done in an effort to determine with exactness the action and theory of this type of generator, the best presentation being that of P. O. Pedersen¹ to which the reader is referred. In the discussion which follows, we have referred largely to his paper and to certain earlier theory as developed by Barkhausen, to which Pedersen also makes reference. Much of the laboratory work done in the past is not applicable to the modern arc generator, due to the wide divergence of the test arc and the generator as designed and constructed for commercial service.

Elementary Theory.—Instability of the Arc.—Consider the ordinary arc circuit indicated in Fig. 1 with the resistance R omitted for the present. The conduction of current through the arc is simply a case of conduction through an ionized gas, in this case vaporized carbon or copper at a very high temperature. Initially, this arc stream of ionized gas is not present, so that to start the current flow in the above circuit, it is necessary to bring the two electrodes in contact. The intense heat developed by the current

¹ "On the Poulsen Arc and Its Theory," Proc. I.R.E., Vol. 5, p. 255, 1917.

passing through the point of contact vaporizes some of the electrode material, and as the electrodes are separated a vapor stream or arc of ionized gas is produced which forms a conducting path for the current. The ionization is assisted by the high temperature of the arc and the bombardment of the negative electrode (cathode) by the positive ions this dissociating the electrode into positive ions and electrons, the latter then being attracted to the positive electrode (anode).

As is the case for practically all gaseous conductors, the resistance of the arc decreases as the current increases. This will be apparent when it is recalled that the resistance of the arc depends on its state of ionization which, in turn, depends on the heating or vaporizing forces which act on the electrodes, caused by the current flowing through the circuit.

Stated briefly, the more current we pass, the more ionized vapor we have, and the more ionized vapor, the "fatter" the arc and the lower the resistance. If the resistance decreases fast enough, the IR drop will decrease, even if the current increases, and this is always the

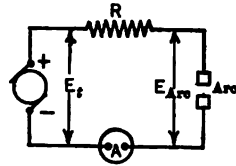

FIG. 1.—The ordinary arc has to have a stabilizing resistance in series with it, or else it is inoperative.

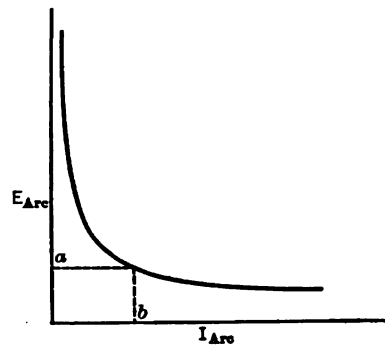

FIG. 2.—Relation of current and voltage across an ordinary arc.

case in the actual arc. The current and voltage relations of such a conductor would appear as shown in the curve of Fig. 2, known as the "static characteristic" of the arc; this name arises from the fact that it is obtained from a series of fixed (static) current values together with the corresponding voltages.

Thus, if an arc were connected directly across a constant-potential supply a short-circuit condition might be immediately attained, the voltage impressed always being above the value required for equilibrium and the current thus continually increasing to make $IR = E$. Since R is very small for a large current, the condition would be equivalent to a short-circuit. On the other hand, if the voltage impressed corresponded to a , Fig. 2, and the current started to decrease below the value b , then the arc current would continually decrease until the arc was extinguished.

Stabilizing Effect of Resistance.—The above phenomenon represents an unstable condition, in which the IR drop decreases automatically with increase in current. A stable circuit is one in which the IR drop increases with current, and to stabilize the arc it is necessary to add additional

resistance R in the circuit, as indicated in Fig. 1. This resistance is the familiar "ballast" resistance used on all arc lamps, and the conditions now existing in the circuit are shown in Fig. 3, an inspection of which

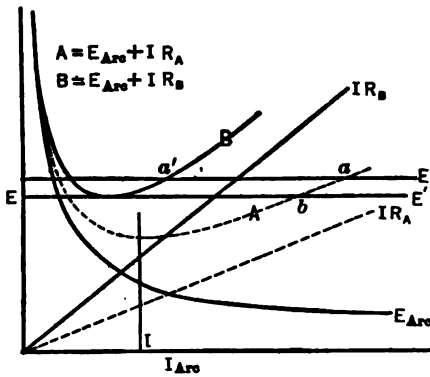

FIG. 3.—Showing the "drops" occurring in the arc equipped with ballast resistance; sufficient series resistance must be used to make the resistance drop across both resistance and arc in series increase with the current.

will indicate how the circuit has been stabilized. Considering curve A , the operation is stable for all currents greater than I , and is unstable for currents below this value. Thus, on the stable portion of the curve, a decrease of voltage results in a decrease of current, and thus a decreased IR drop across the resistance. The voltage across the arc therefore rises, and initial conditions are restored. The current value may be controlled by varying the terminal voltage, as shown by the two current values a and b on the characteristic curve A , or by changing the amount of ballast

resistance used, as shown by the current values a and a' for two different characteristics A and B for the same terminal voltage. If impressed voltage is reduced to the minimum value (E' for curve B) then the arc may operate or may go out. This point is therefore called the point of "indifferent" stability.

The function of the ballast resistance is thus to stabilize the operation of the arc for slow changes of voltage. Commercial arc generators have this resistance short-circuited when operating steadily, to increase the efficiency, the inductance and inherent resistance of the circuit being sufficient to stabilize the circuit.

Effect of Inductance—Choke Coils.—If a very high inductance is inserted in the circuit as shown at L' (Fig. 4) very quick changes of generator current are minimized and prevented to a large extent. Thus if a sudden increase of generator voltage occurred, the current would tend to increase, and would increase slightly, setting up a counter e.m.f. of self-induction at L' , which would minimize the variation of current. It is important to note that the inductance, in order to be effective, requires

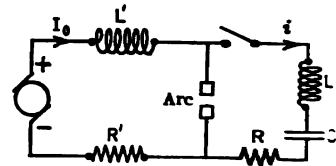

FIG. 4.—If a circuit of L and C in series is shunted around an arc supplied from a continuous-current generator through choke coil L' , an alternating current will flow in the circuit made up of L , C , R , and arc in series.

a variation in the current flowing through it, and the arc supply is therefore not strictly a constant-current source. This variation may be made extremely small, however, by using large inductance values.

A Simple Explanation of the Operation of the Oscillating Arc.—If a condenser, in series with an inductance, is connected to a source of electric energy, of voltage E , the current which flows after closing the switch is an oscillatory one,¹ its frequency being fixed by the natural period of the oscillatory circuit and its magnitude depending upon the voltage E , and the ratio C/L . This oscillatory current dies away due to the damping, and the condenser is finally charged to a potential difference E , and there is no current in the circuit.

Suppose an arc, connected as in Fig. 4, is burning steadily (switch in the oscillatory circuit being open), with a difference of voltage across the two electrodes equal to E . When the switch is closed the current flowing in the L, C, R circuit is given by ²

$$i = E\sqrt{\frac{C}{L}}\epsilon^{-\alpha t} \sin \omega t. \quad (1)$$

Now by inspection of Fig. 4 it is evident that this current must be robbed from the arc, because the value of L is always chosen large enough to prevent rapid variations of current from the generator. Hence when the current i starts to flow the arc current starts to decrease, being always equal to $I_0 - i$. But we have seen that it is a characteristic of the arc that when its current decreases the voltage across it increases; hence Eq. (1) does not correctly represent the current into the condenser, unless E is made to depend on i for its value. Actually the current is greater than indicated by Eq. (1), because of the increase in E during the time i is flowing in the direction indicated in Fig. 4.

The increase in E during the first alternation is not great, because the amount of current taken by the condenser is only a small fraction of the arc current. Thus if the arc is burning with 50 volts across the gap and 10 amperes is flowing, the decrease in current upon first closing the switch (Fig. 4) will probably be less than 10 per cent of the arc current. The value of $\sqrt{\frac{L}{C}}$ used in the oscillating circuit should not be less than about 50; its normal value is perhaps 200. This value substituted in Eq. (1) shows that during the first alternation of the oscillatory state the maximum value of condenser current will be less than 1 ampere. The condenser will charge up to a voltage about twice that of the arc ³ and then start to discharge; the current during discharge adds to the current

¹ For analysis of this action see Chapter IV, p. 249.
² Eq. (11), p. 208.
³ See Chapter IV, p. 251.

through the arc and thus gives it greater than normal value. This results in a *decrease in voltage across the arc*, thus tending to facilitate the discharge of the condenser, thus producing a greater discharge current than would have occurred if the arc voltage had held constant.

It will thus be seen that the voltage-current characteristic of the arc tends to give a greater current in the condenser during both the charge and discharge periods, than would occur if the arc voltage were independent of the current through the arc.

Now the current flowing into the oscillatory circuit is supplied when the arc voltage is *higher than normal* and the current flows out of the oscillatory circuit (against the influence of the arc voltage) when the arc voltage is *less than normal*. As energy is being supplied to the oscillatory

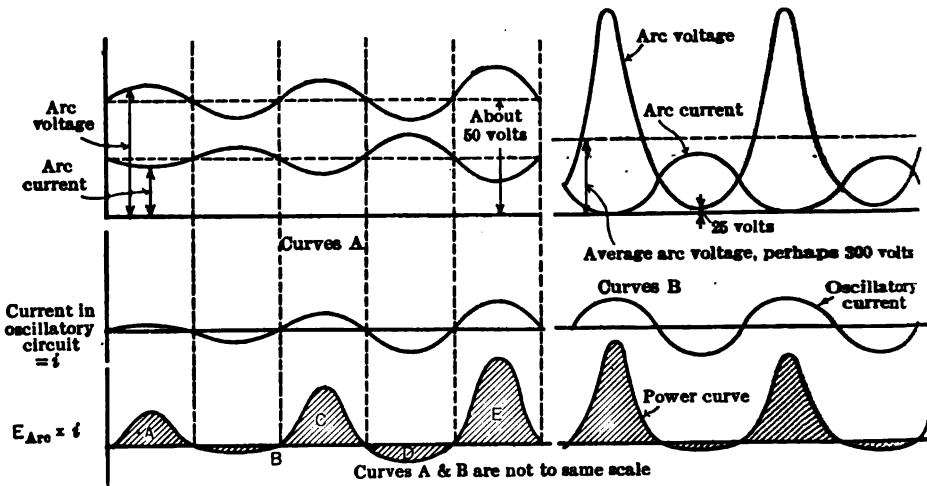

FIG. 5.—A simple explanation of the oscillating arc can be obtained from these curves; curves A show the start of oscillations and curves B give the conditions when the oscillations have reached the steady state.

circuit during the charge and extracted during the discharge, from the conditions just cited it is evident that *more energy is supplied to the oscillatory circuit from the arc supply circuit during the charge than is given up to the arc during the discharge*. Unless too great a resistance is present in the oscillatory circuit this action results in a building up of the current in the oscillatory circuit, and this building up will increase until the maximum value of the oscillatory current is practically equal to the generator current, I_0 .

This action is shown by curves A of Fig. (5); the curves of which are nearly self-explanatory; the current in the oscillatory circuit is reckoned positive when it is flowing in the direction indicated in Fig. 4.

The lower curve of Fig. 5 is the product of the current i and the voltage acting on the oscillatory circuit. Area A gives the energy supplied to the oscillatory circuit by the arc during the first alternation, and area B gives the energy supplied by the oscillatory circuit to the arc during the second alternation. The difference, $A-B$, gives the energy supplied to the oscillatory circuit during the complete cycle, and if this is greater than the I^2R loss in the oscillatory circuit during the cycle the oscillatory current will continue to increase until some other factor controls the action.

The excess of area A over area B depends upon the arc characteristic, being greater as the characteristic curve (Fig. 2) becomes steeper; as to whether or not the excess is sufficient to build up oscillations depends upon the resistance of the oscillatory circuit. These two factors control completely the operation of the arc; it must be remembered, however, that the relation between arc voltage and arc current used in plotting Fig. 5 must be determined from the oscillatory state because the static characteristic gives too great a difference in areas A and B . The variation between the static characteristic and dynamic characteristic increases with frequency, in such a way that at high frequency (say 500,000 cycles per second) the difference between areas A and B is not sufficient to produce much oscillatory power.

A simple arrangement of apparatus which has nearly the same action as the arc is shown in Fig. 6. A source of e.m.f. is connected to a resistance R which is fitted with a sliding contact, B . Between the lower point of the resistance R and the contact B is connected an oscillatory circuit consisting of L and C in series.

Suppose that, with B in the middle of R , switch S is closed; current will immediately start to flow as indicated by i , charging condenser C . Now as C starts to charge contact B is moved up on R , thereby increasing the voltage impressed on the $L-C$ circuit. The motion of B is so regulated that it reaches B' in an interval just equal to one-quarter of the natural period of $L-C$; it then starts to move down on R and reaches point B'' in an interval equal to one-half of the natural period of $L-C$. Thereafter the contact oscillates between B' and B'' , making a complete cycle in a time equal to the natural period of $L-C$.

Such an arrangement will result in the building up of a large oscillating current in the $L-C$ circuit, the magnitude being limited only by the voltage E and the resistance of the oscillatory circuit.

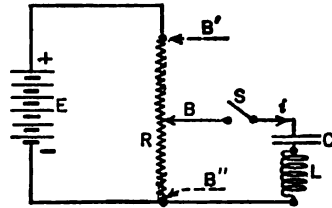

FIG. 6.—A simple circuit which may be made to operate the same as an oscillating arc.

Types of Oscillation.—The types of oscillation which may be generated have been arbitrarily designated on the basis of the minimum arc current value as follows:

Type I. Minimum current is greater than zero.

Type II. Minimum current is equal to zero.

Type III. Type II with immediate re-ignition, resulting in production of trains of damped oscillations.

Type I Oscillations.—In this type of oscillation the operation is essentially as given above in the simple explanation of arc action. The amount of alternating-current power generated is not as great as the device is capable of delivering, and the efficiency of conversion is comparatively low, probably less than 40 per cent. The action of the arc with this type of oscillation is very steady, however.

Type II Oscillations.—With type II oscillations the arc current goes to zero, as a minimum value for an appreciable part of the cycle. In this case the maximum value of the radio frequency current is somewhat greater than the value of the essentially constant direct current flowing through the arc, or

$$I_{ac}\sqrt{2} > I_{dc}.$$

Under this condition the arc is extinguished and no current flows across it for a small interval of the time of each charging alternation. During this interval the steady direct current flows into the condenser, however, charging it to the same polarity and potential as at the beginning of the preceding discharge cycle. The time required to charge the condenser and amount of charge depend largely on the state of ionization of the arc. If the ignition voltage is low, the amount of this charge will be decreased, and the amplitude of the radio frequency oscillation will be correspondingly decreased. This is the case if the arc is not deionized rapidly enough, or if the electrode separation is made too small.

The curves of current and voltage for this case would be (according to accepted authorities) approximately as shown in Fig 7.¹ During the interval from *a* to *b* constant current (from d.c. supply) is flowing in the oscillatory circuit and thus the drop across the *L* of the oscillatory circuit is zero. Therefore $E_{arc} = E_c$ and since the condenser current is constant, $\frac{dE_c}{dt} = K$, or voltage curve must be a straight line during this interval.

These characteristics hold only if the arc is comparatively long, much longer than is normally used in the commercial arc, to which they are therefore not applicable. The greater distance between electrodes entails

¹ Zenneck, "Wireless Telegraphy," pp. 234-236.

a decreased efficiency due primarily to the higher voltage required to keep the arc ignited. The arc is also more apt to blow out. The greater ignition voltage required causes a corresponding increase in the time of charging, which is not conducive to a constant-frequency generation. It should be noted that the arc separation cannot be made too small, however, as with this condition the arc current tends to remain constant in value and (the static characteristic being very flat in this region) but little variation of the voltage across the arc occurs. Thus the periodic charge and discharge of the shunting condenser does not take place with much vigor. The arc therefore requires a certain minimum length to be active.

Type III Oscillations.—

The third form of oscillation represents an abnormal operating condition, such as may exist with the gap too short. The maximum amplitude of the radio frequency current in this case also is greater than the steady d.c. current and as a

consequence the arc current goes to zero. The arc, however, due to its ionized condition, and the high voltage across it at that instant, immediately reignites, and the condenser current flows through the arc without interruption (practically). The voltage across the arc thus has no opportunity to rise, and comparatively small charging potential is impressed on the condenser by the supply circuit. The discharge is therefore similar to the discharge which occurs in the closed circuit of a spark transmitter, the oscillations decreasing until the energy initially stored has been dissipated in the circuit. As the current decreases, the voltage (a.c.) also decreases, until it reaches a value when it is no longer able to reignite the arc. The arc is then extinguished and the supply circuit again feeds into the condenser circuit, charging the condenser until the ignition voltage is reached, whereupon discharge occurs and the above events are repeated.

The result is a series of damped high-frequency wave-trains, exactly similar to those produced by the spark transmitter, but the group frequency is very much greater, since the interval between trains is determined by the time required for the supply potential to charge the condenser up to the ignition voltage value, which time is very short.

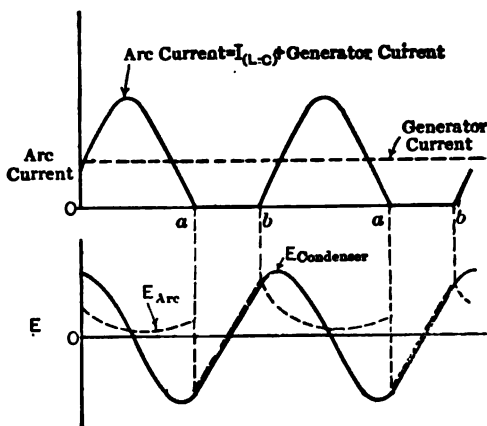

FIG. 7.—Action of the arc when the arc current remains zero for an appreciable fraction of a cycle.

The characteristics of this type of oscillation are indicated in Fig. 8.¹ During the interval between two groups of oscillations the voltage across the arc is shown as uniformly increasing from a small to a high value, but as the arc is extinguished during this interval, it is evident that this can only occur if the d.c. supply current is decreasing more and more rapidly during this interval. While this is not apparent in Zenneck's figure, it is evident that such must be the case if the explanation is to hold good.

Normal Poulsen Arc.—It is important to note that the three classes of oscillations described above do not in any case exactly apply to the operation of the modern Poulsen arc. Present generators, of all capacities

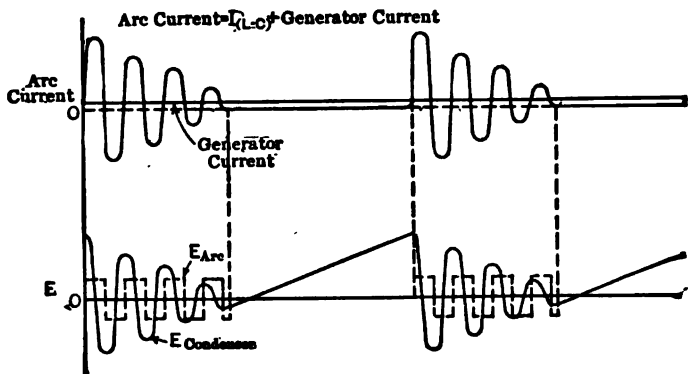

Fig. 8.—Supposed action of an oscillatory arc, the length of which is much less than normal.

up to 1000 kw. (input) utilize what has been designated as the "normal Poulsen arc." In this arc the ratio of direct current in the supply circuit to the radio frequency current (effective value) is always equal to the $\sqrt{2}$, or:

$$I_{dc} = \sqrt{2}I_{ac}$$

where I_{ac} is the effective value of the current in the oscillatory circuit.

The normal arc therefore represents the division limit between oscillations of type I and type II, its characteristics being somewhat similar to those of type I, as shown in Fig. 9.²

Professor Pedersen in his paper previously referred to emphasizes the importance of the extinction voltage on the characteristics of the normal arc. As the arc current approaches the zero value, the arc voltage suddenly rises, as shown in the above figure. The arc must be able to develop this voltage if operation is to be efficient. Previous theory has

¹ Zenneck, "Wireless Telegraphy," p. 237.

² Ibid., p. 236.

neglected this portion of the characteristic, principally because investigators worked with comparatively long arcs, for which the preceding explanation (Fig. 7) is adequate, as the extinction voltage in this case is very small compared to the ignition value.

It seems to the author that none of these curves (Figs. 7, 8 and 9) represents the conditions as well as that given in Fig. 5. It is to be noticed that if the action shown in Fig. 5 is continued for many cycles the difference between the arc voltage during charging of the oscillatory circuit condenser and that during discharge continually increases; this is indicated by curves *B* of Fig. 5, which represents the condition perhaps 100 cycles after the oscillations start.

It is to be noted that here the current has reached a steady value (fixed amplitude) and that the arc voltage pulsates between perhaps 25 volts and a very high value, that corresponding to practically zero current in Fig. 2. Fig. 5 brings out a relation seldom mentioned by writers,

that the reading of a continuous-current voltmeter across the arc is about 50 volts before oscillations begin but immediately jumps to 300 or more when oscillations start; in fact the reading may be as much as perhaps 500 volts if a sufficiently high-voltage power supply is used. A c.c. voltmeter reads average values, hence the change in reading from 50 volts to 300 volts indicates that the maximum voltage across the arc may be 1000 or more; as the duration of this high voltage is only a small fraction of a cycle its value may be three or four times the average value, i.e., the reading of the continuous-current voltmeter across the arc.

Practical Construction of the Arc Generator or Converter.—To increase the power, efficiency, and constancy of frequency of the arc generator, several special devices are employed. These devices are the result of extended investigations carried out by V. Poulsen, and their application has been primarily responsible for the rapid development and commercial success of this type of generator. Previous to this time many investigators had utilized the fundamental arc circuit, but had not succeeded in obtaining sufficient high-frequency energy to permit the operation being considered a practical success. Poulsen's investigations offered the first solution and demonstrated that the simple arrangement of Fig. 4 would give

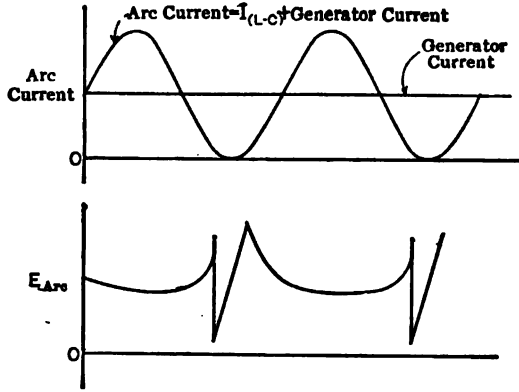

Fig. 9.—Voltage and currents for the "normal" arc.

undamped oscillations at constant radio frequencies and sufficient energy for the purposes of radio telegraphy and telephony if modified as follows:

1. The arc is caused to take place in hydrogen or a gas rich in hydrogen.
2. The positive electrode is kept as cool as possible, and therefore is constructed of some material having a high heat conductivity, usually copper, cooled by circulating water. The negative electrode is of carbon and is rotated slowly on its axis while the arc is in operation, to improve the regularity of the oscillations.
3. The arc is acted upon by a transverse magnetic field, which assists in the rapid deionization (scavenging) of the gases in the arc. The electro magnets supplying this magnetic field are sometimes connected directly in the supply circuit as indicated in Fig. 10.

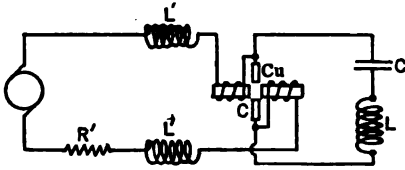

FIG. 10.—The ordinary Poulsen arc burns in a hydrogen vapor, in a transverse magnetic field and has a water-cooled anode. Resistance R' is cut out when the arc is oscillating.

magnets supplying this magnetic field are sometimes connected directly in the supply circuit as indicated in Fig. 10.

The strength of this field affects the characteristics of the arc to a considerable extent, and if not of the correct value, inefficiency and inconstancy of oscillation result. As expressed by Professor Pedersen:

“The arc should burn in the weakest field in which it works normally, only igniting once a period, and always on the electrode edges. Both stronger and weaker fields require excessive supply voltage. This is therefore the most suitable field intensity—the one giving the highest efficiency and the most constant behavior of the arc.”

If the field is made too strong, the increase in resistance, due to the stretching out of the arc as it is being extinguished, causes the extinction voltage (the potential across the arc at the instant the arc current has fallen to zero) to reach excessive values. This excessive voltage may cause a reignition of the arc across a shorter path and interfere with the constancy of the oscillations.

If the field is too weak, the conditions for successive arcs (in successive cycles) are not constant, due to the fact that ignition does not take place from the same point of each electrode, but from the points where the preceding arc existed at the instant of being extinguished. The arc length thus grows successively longer and longer until the arc can no longer ignite across the longer distance.² Ignition then takes place between the electrode tips again and the process is repeated. This also causes a variation in the frequency as the conditions for successive arcs are not constant (arc resistance, charging period, etc.). Since the proper action of the

² The reader is referred to the photographs in Pedersen's paper for evidence of the correctness of these statements.

field consists in blowing out the arc and allowing a new arc to form at the beginning of the next period, it is evident that its intensity will depend on the frequency to be generated. Pedersen has found the proper field intensity to be approximately proportional to the frequency. Thus with an arc drawing about 20 amperes from the supply line, and an oscillatory circuit with a ratio of $\sqrt{L/C}$ about 300, Pedersen found the most suitable field strength to be given by the relation $(H+400)\lambda=5000$, in which H is in gaussses and λ in kilometers. With a hydrogen atmosphere it seemed that a field about one-fifth as large as this was proper.

Action of the Gaseous Atmosphere.—The hydrogen or coal gas in which the arc usually operates assists in cooling the electrodes, and thus when the arc current falls to zero, the cooling action of the gas promotes a rapid increase in the arc resistance (deionization). It also affects the static characteristic, making it steeper than in air, as shown in Fig. 26, page 141.

The reason for the hydrogen atmosphere thus steepening the curve is not known, but the effect of this increase in slope upon the arc operation is evidently to cause the arc voltage variation (which in turn acts to charge the condenser) to be more sensitive and of greater amplitude for a given arc current variation. The radio frequency energy input is thus increased.

The foregoing features of construction are embodied in all modern arc generators. Fig. 11 illustrates a 500 kw. arc (input rating), which is much less than the maximum capacity to which generators of this type have been built up to the present time.

Generators of 1000 kw. capacity are of the same general construction, but somewhat smaller in size. The arc chamber is equipped with a water-cooled jacket to assist in cooling the chamber, while the copper anode has circulating water supplied to it by means of flexible pipe connections. The negative electrode is usually of carbon, although graphite is being largely used for the higher capacity arcs. The anode, as shown in the figure, is equipped with handwheels to permit the accurate adjustment of the gap length. The smaller wheels shown are used for clamping the electrode into its proper position. The enormous size of magnetic circuit apparently required for these large capacity generators is indicated in Fig. 11 as well as in Fig. 12, which shows the generator with the electrodes and arc chambers removed; the circuit shown in the latter figure is for a 500 kw. arc, the upper pole piece having been removed.

Arc generators are most efficiently used at the longer wave-lengths and are therefore usually operated at 3000 meters or above, 6000 meters being the wave-length generally used. In some cases the wave-length is as high as 18,000 meters. The capacities range from 100 kw. or less up to 1000 kw.; 350 kw. arcs are generally used for high-power land

stations. Small-capacity arcs, with a capacity of 20–30 kw., have been in successful use on board ship. The usual wave-length is 4000 meters.

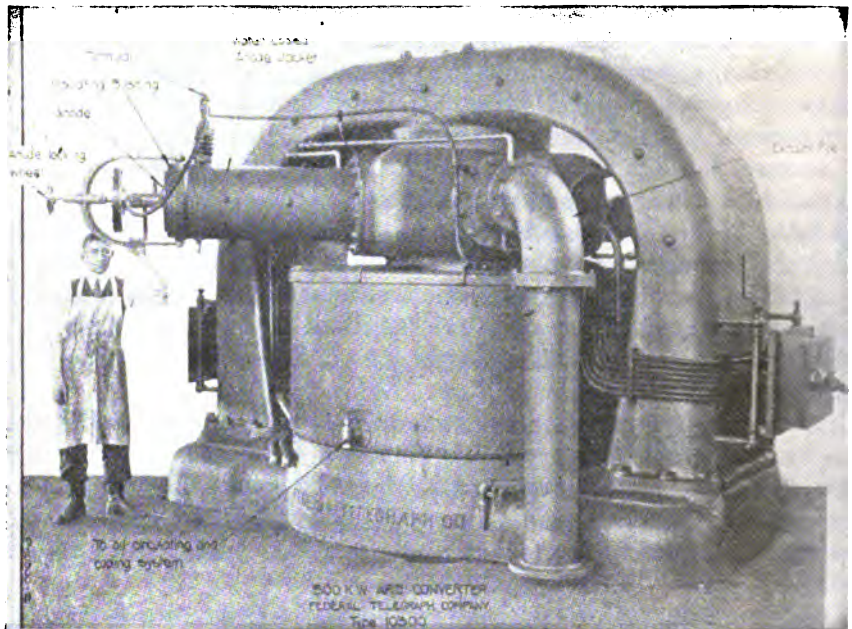

FIG. 11.—A 500 kw. Poulsen arc converter; over the operator's head is the anode terminal and on the right is shown the pipe for carrying off the exhaust gases from the arc chamber. (Proc. I. R. E. Vol. 7., No. 5).



FIG. 12.—Magnetic field structure for a 500 kw. converter; the proper form of pole piece has been subject of considerable study. (Proc. I. R. E. Vol. 7., No. 5.)

and the sets have a transmission range of perhaps 2000 miles in the day-time. Just recently small arcs (2 kw. input) have been constructed,

which when fed from a 600-volt line seem to operate satisfactorily for wave-lengths as short as 800 meters.

High-frequency Alternator.—The generation of high-frequency currents by means of machines similar in their principles of construction to the huge alternators which supply the modern central-station loads, has doubtless occurred to the student. The extremely high frequencies required, however, necessitate machines of special design which require a high grade of engineering skill in their construction. Alternators for supplying loads of commercial frequency may be any one of the three following types:

I. The armature is the rotating element, the d.c. field being stationary. This arrangement is similar to that employed on all d.c. generators but is rarely used on alternators, particularly the large sizes.

II. The field rotates with respect to the armature, which is fixed in position. This construction possesses several advantages over type I, particularly due to the lesser insulation requirements of the field winding and its greater simplicity as compared to the armature winding. This construction is universal on all modern alternators.

III. Both the field and armature windings are stationary in space, the flux linking the armature winding being periodically varied by means of an inductor, revolving in the air gap. This inductor is essentially a disk whose periphery has been divided into sections, alternate sections possessing a high magnetic reluctance, while the intermediate sections, which are made of steel, possess a relatively low reluctance. This type is practically unused in the low-frequency machines of commercial engineering, but possesses several inherent advantages which make it the most satisfactory of the alternators designed for high-frequency generation. Since both windings are fixed, in position, their proper insulation is much simplified. Very serious difficulty is encountered when it is attempted to place an insulated winding on the revolving member (rotor), due to the high peripheral speeds and consequently high centrifugal stresses involved.

Design of the High-frequency Alternator.—That a special construction and design is required may be seen from the following: If we consider a machine of the inductor type having a maximum permissible speed of 20,000 r.p.m. and a required frequency of 100,000 cycles per second, the rotor diameter being assumed 30 centimeters, the distance through which a point on the rotor moves in generating one cycle is

$$\frac{\pi \times 30 \times \frac{20,000}{60}}{100,000} = 0.31 \text{ cm.}$$

Therefore, in this small space we must have a section of high reluctance (for instance, bronze) and a section of low reluctance (steel) so that a

complete cycle of flux variation from minimum to maximum and back to minimum occurs while the inductor moves through this space. Special precautions in design and materials used must be observed if the hysteresis and eddy current losses are to be minimized, as these become very large at the higher frequencies.

Construction.—The construction of the Alexanderson high-frequency alternators (first suggested by R. A. Fessenden), is indicated in Fig. 13.

The pole pieces *BB* are threaded into the yoke *A* as indicated, the air gaps being thus accurately adjustable. The pole tips *NS* are finely

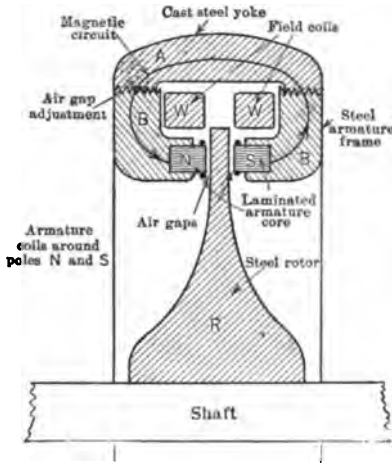

FIG. 13.—Simplified cross-section of an Alexanderson alternator.

laminated to reduce eddy current and hysteresis losses and are slotted to receive the armature winding. The field windings *WW* are installed as shown, and with a steady direct current flowing through them, set up a flux as indicated by the dotted line. It is evident that the reluctance of this circuit will vary as the inductor *R* rotates between the two faces of the air gap. This inductor is properly designed for the high stresses which exist when it is operated at its rated speed of 20,000 r.p.m. The rim velocity under this condition is about 300 meters per second and the centrifugal force at the periphery is 68,000 times the weight of metal there.

A developed view of the winding and rotor is shown in Fig. 14. If we consider the loop formed by conductors 6-7, the flux linking it will be a maximum with the inductor in the position shown. As the inductor moves to the right, the tooth *e* is replaced with a non-magnetic insert and the flux decreases to a minimum value. Then as the inductor continues to move to the right the tooth *d* enters the loop 6-7 and the flux increases again to a maximum. The variation of flux and corresponding induced voltage $\left(E = \frac{d\phi}{dt}\right)$ is indicated on the figure. It will be noted that a complete cycle is generated while the rotor travels a distance represented by the tooth pitch (distance of a point on a tooth to similar point on adjacent tooth). The frequency is thus equal to the number of inductor teeth multiplied by the revolutions per second.

The effective number of poles for this type of machine is evidently

twice the number of inductor teeth or spokes. Thus to generate 100,000 cycles we would require

$$N = \frac{f}{\text{rps}} = \frac{100,000}{\frac{20,000}{60}} = 300 \text{ spokes on the inductor}$$

An examination of the winding indicates that loops 2-3, 10-11, etc., pass through the same flux variations as loop 6-7, and as these loops are all connected in series the voltage will add up around the periphery. The same analysis holds for loops 1-4, 4-5, 5-8, etc. The windings are brought out to separate terminals and may thus be connected in series

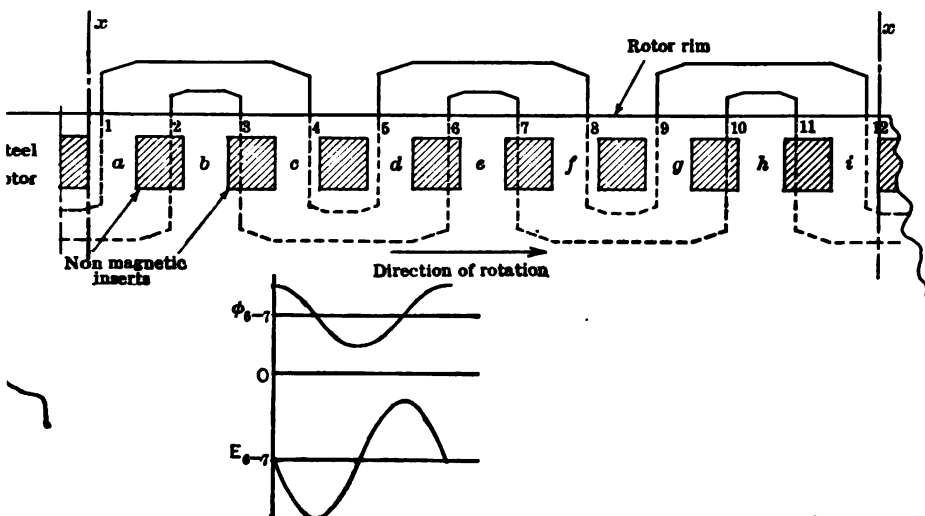

Fig. 14.—Developed view of the winding and rotor of the machine shown in Fig. 13.

or parallel, whichever may be most suitable for the conditions involved. It should be remembered that two similar windings are placed in the pole tip on the near side of the air gap, which are not shown in the figure. Thus the operator has four or more separate windings which he may connect in any arrangement most desirable for his conditions. On the alternator at the New Brunswick station, each coil has its terminals brought out, there being 64 such coils.

On the normal inductor generator, the number of armature slots is always equal to the effective number of poles. In the Alexanderson machine the number of armature slots may be two-thirds the number of poles. This is a distinct advantage, as more space and more thorough insulation is thus permitted for the winding. Thus in the figure, we have between the lines xx , twelve armature slots and nine inductor spokes,

which represent eighteen effective poles, or the armature slots are two-thirds the effective poles.

The greater the flux variation $\left(\frac{d\phi}{dt}\right)$ the greater will be the generated voltage. By decreasing the air gap the effect of the inductor on the flux becomes more pronounced and thus the generated voltages increase. On a certain machine, with a minimum permissible air gap of .004 inch (for each of the two gaps), the voltage generated was nearly 300 volts. With the air gaps increased to .015 inch each, the voltage decreased to 150. (Eccles.) Similarly, the output capacity increases as the air gap is decreased and vice versa.

The highest frequency for which these machines have been constructed at the present time (1920) is 200,000 cycles per second with a capacity of about 1 kw. Machines of 50 kw. and greater have been constructed, the frequency, however, being lower for these higher capacity machines, usually about 50,000 cycles. A 2-kw., 100,000-cycle generator is indicated in Fig. 15, showing the driving motor, normally operating at 2000 r.p.m., connected through special 1 : 10 gears to drive the alternator shaft at 20,000 r.p.m. This general arrangement is followed on all alternators of this type, the gear ratio decreasing as the capacity increases. On some machines the driving motor is connected to the low-speed gear shaft by means of a chain connection. A view of one armature of a 2-kw., 100,000-cycle machine is shown in Fig. 15A.

As might well be supposed, the high-speed machines are not as reliable in operation or as easy to maintain as a low-frequency machine of the same power. The bearings of the machine shown in Fig. 15 are flexibly fastened to the bed plate of the machine so that as the armature shaft expands each bearing will move away from the rotor disk equally, thus maintaining the two air gaps equal. Forced oil feed must be used for the bearings and for the larger machines, pipes carrying cooling water are liberally distributed throughout the structure of the machine.

The high peripheral speed of the disk results in a very rapid circulation of air through the two air gaps, causing considerable noise and power consumption. The small machine shown in Fig. 15 requires about 7 h.p. to turn the disk at rated speed, the machine not being loaded.

These high-frequency inductor alternators require suitable tuning condensers to neutralize their internal reactance before they can deliver appreciable power; a small 200,000-cycle machine will scarcely deflect a voltmeter across its terminals unless a proper condenser is connected across the armature terminals.

Connection to the Antenna.—The armature winding may be directly connected to the antenna as shown in Fig. 16a, or it may be inductively coupled as shown in Fig. 16b, by using an oscillation transformer. In

either case the antenna circuit must be tuned to the frequency of the alternator if maximum output is to be obtained. If the 2-kw. 100,000-

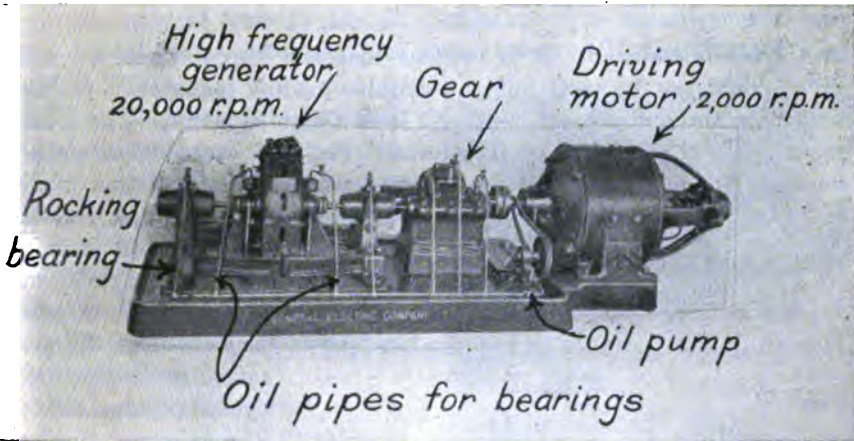

FIG. 15.—View of a small 100,000 cycle Alexanderson alternator.



FIG. 15A.—A view of a section of one armature of the machine in Fig. 15.

cycle machine is considered, its reactance at this frequency with normal air-gap, may be taken as 5.4 ohms or

$$L = \frac{5.4}{2\pi \times 100,000} = 8.58 \mu h.$$

Thus the antenna capacity (Fig. 16a) must be such that

$$3000 = 1885\sqrt{LC} = 1885\sqrt{8.58C}$$

or $C=0.3$ microfarad. It is evident that the direct connected scheme (16a) could not be used unless a suitable loading inductance (L') were added, as antennæ are not built with such a high capacity. The arrangement utilizing an oscillation transformer (Fig. 16b) would most probably be used in any case. The maximum continuous load of this machine is 30 amperes at 70 volts, or the equivalent antenna circuit resistance as measured at the terminals of the generator must thus be $\frac{70}{30}=2.3$ ohms.

Application.—At this time the Alexanderson alternator is rapidly increasing in importance and application, particularly the lower-frequency machines (20,000–50,000 cycles) of large capacity. The inherent disadvantages of this type of generator due to the high speeds and complications attendant thereto, such as lubrication, etc., apparently prevent it from representing a practical means of generation on board ship, or for small-power installations or portable field service.

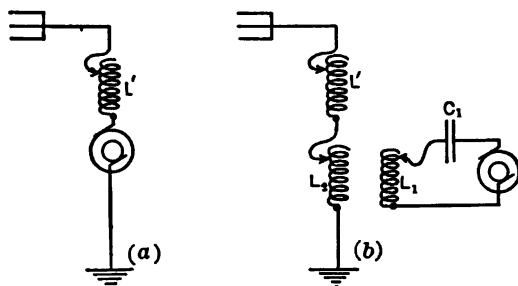

FIG. 16.—Two schemes for connecting a high-frequency generator to an antenna; that shown in (b) is generally used.

For high-power land stations, however, engaged in transoceanic and transcontinental service, it will probably be increasingly successful in application and performance. It is also adaptable to the requirements of radio telephony. (See Chapter VIII.) The most successful station utilizing this type of generator is located at New Brunswick, N. J., where a 200-kw. set is installed. This equipment is shown in Fig. 17. For a further description of this machine and station the reader is referred to a paper by E. F. W. Alexanderson.¹

One of the chief difficulties in the operation of a high-frequency alternator is the accurate control of its speed. An almost imperceptible change in alternator speed will result in the pitch of the signal note at the receiving station changing several octaves. That the Alexanderson generators are controlled in speed to better than 0.1 per cent can be told at once by noting the constancy of pitch of the signal received from the

¹ "Transatlantic Radio Communication," Proc. A. I. E. E., Oct., 1919.

New Brunswick station. An ingenious arrangement of relays operate on the driving motor so as to make its speed essentially constant.

The Goldschmidt Alternator.—Theory.—This generator, first brought out in commercial form by Dr. R. Goldschmidt, is based on principles which are radically different from those involved in the Alexanderson machine. These are:

1. The magnetic field produced by an alternating current of frequency n , may be considered as consisting of two component fields, the magnitude of each of these fields being one-half the magnitude of the resultant total field and considered as rotating in opposite directions at frequency n .

This is simply the theory of conjugate vectors and is illustrated in Fig. 18. Fig. 18A represents the normal derivation of a sine curve from a rotating vector while Fig. 18B utilizes the principles of conjugate vectors; the horizontal components of ϕ' and ϕ'' neutralize one another, while the resultant vertical component is at all times as indicated by the sine curve to the right. Similarly, the current I could be represented in the same manner. The construction illustrates graphically the principle stated above.

2. If a coil (rotor) is revolved in this alternating magnetic field at synchronous speed, it is apparent from the foregoing that the component fields will induce e.m.f.'s of different frequencies, since they are rotating in opposite directions. If we assume the coil to revolve in a counter-clockwise direction, flux ϕ' will rotate with it, thus cutting no conductors and generating no e.m.f. in the coil. The other component ϕ'' is moving against the rotation of the coil. Thus the frequency will be twice what it would be if



FIG. 17. Views of the high-powered Alexanderson generator installed at New Brunswick; over the alternator (in the lower view) may be seen the oscillation transformers which connect the generator to the antenna.

the coil were standing still. Reviewing the above, two frequencies may be considered as being generated in the coil, viz.,

$$f_1 = N - N_r \text{ (produced by } \phi')$$

$$f_2 = N + N_r \text{ (produced by } \phi'')$$

$$\text{since } N_r = N,$$

this becomes

$$f_1 = 0$$

$$f_2 = 2N$$

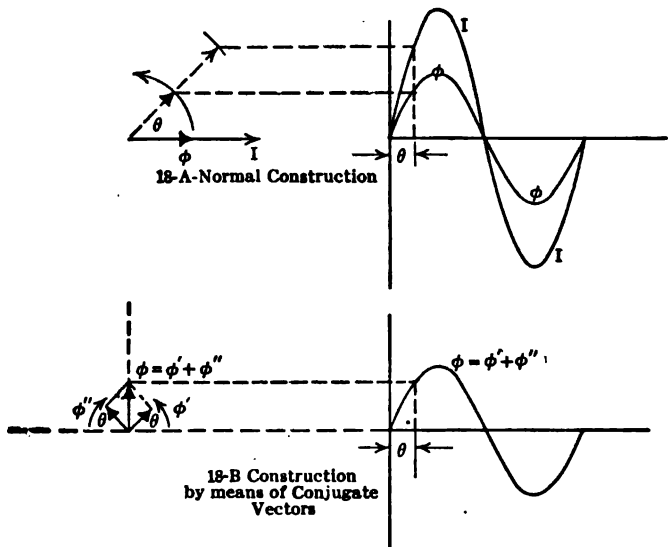

FIG. 18.—A stationary, pulsating, magnetic field may be represented by two rotating fields each constant in strength, rotating in opposite directions. Each rotating field has one half the strength of the stationary pulsating field.

In these expressions N is the frequency of the alternating field, while N_r is the rotational speed of the coil expressed in cycles per second. Therefore, if the terminals of the rotating coil are connected together, a current will flow in the circuit whose frequency is $2N$, and a doubling of the initial frequency N has been obtained. It is evident that this double-frequency current could be led to a second fixed coil, with a revolving coil placed in the influence of its magnetic field and a further doubling of frequency would result. (If the coil is rotated at a frequency $2N$.) If the speed of rotation is N_r , as for the first case, the frequencies would be

$$f_1 = N - N_r = 2N - N = N$$

$$f_2 = N + N_r = 2N + N = 3N$$

A practical example of these effects is found in the double-frequency component which appears in the d.c. field circuit of a single-phase alternator when the machine is carrying load. This is illustrated by the ondograph record shown in Fig. 19, in which the 60-cycle armature e.m.f. and the 120-cycle ($2N$) e.m.f. induced in a search coil on the pole are both shown. The field winding revolves at synchronous speed in an alternating

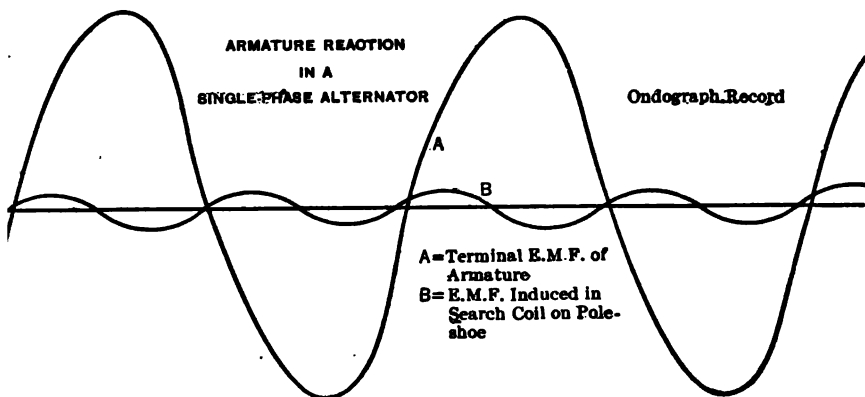

FIG. 19.—Ondograph record from a single-phase alternator; curve *B*, obtained from a search coil on the pole face shows a frequency twice as great as that generated in the armature.

field produced by the current in the armature winding. We thus have, as for the first case cited above.

$$f_1 = N - N_r = 0$$

$$f_2 = N + N_r = 2N$$

It has already been indicated how additional increases in frequency might be obtained by using a number of machines (consisting of a fixed and movable coil) connected in cascade. However, instead of having the rotor currents excite a distant stator, it is more practical and economical to have it react back on its own stator. The fundamental connections would then be as shown in Fig. 20.

Connections for Increasing Frequencies in the One Machine.—The source of power, *A*, supplies current of frequency N to the stator winding *S* and the rotor winding *R* rotates in this field at synchronous speed (in r.p.m. = $\frac{N \times 120}{\text{no. of poles}}$). There will thus be induced in *R* an e.m.f. of frequency $N - N = 0$ and an e.m.f. of frequency $N + N = 2N$. If the terminals are joined by a low-impedance path, a current of this frequency will flow in the rotor circuit. Associated with this current is

a magnetic field whose frequency is $2N$. Recalling that we may represent this field by two oppositely rotating fields, whose frequency is $2N$, it is evident that one component (the one revolving in the same direction as the rotor) will cut the stator at a frequency $2N + N = 3N$, while the other component will cut it at a frequency $2N - N = N$, corresponding e.m.f.'s being induced in the stator circuit. If the terminals of the stator coil

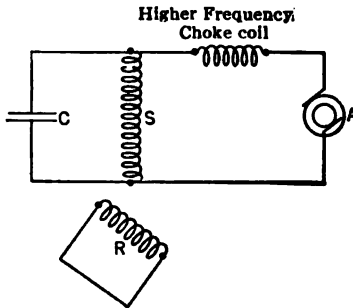

FIG. 20.—Conventional diagram of rotor coil R , and tuned stator circuit $S-C$, supplied with magnetizing current through choke coil.

be joined by a suitable circuit, currents of these frequencies will flow. Furthermore, the field set up by the triple-frequency current will induce in the rotor e.m.f.'s of frequency $3N - N = 2N$ and $3N + N = 4N$, and currents of these frequencies will flow in the rotor circuit. In turn, the current of frequency $= 4N$, will induce in the stator e.m.f.'s of frequency $4N - N = 3N$ and $4N + N = 5N$. Thus, if we assume an initial supply frequency to the stator of 10,000, we have transformed it by means of so-called "electrical reflections" outlined above, into

a frequency of $5N = 50,000$, which may be employed for radio-telegraph and radio-phone transmission.

These several e.m.f.'s may be tabulated as follows:

Stator	Rotor
N	$2N$ and 0
$3N$ and N	$4N$ and $2N$
$5N$ and $3N$	

If, instead of supplying alternating current to the stator winding, we employ direct current, the results are, similarly:

Stator	Rotor
0	N
$2N$ and 0	$3N$ and N
$4N$ and $2N$	

This is the usual arrangement for commercial machines, the source of supply being a storage battery or d.c. generator.

Application of Tuned Circuits.—In discussing the reflection of frequencies we have indicated the coil circuits as being completed in the rotor by a short-circuiting resistance while the stator circuit is completed by a condenser. Since the coils themselves possess considerable impedance at the high frequencies involved, this must be compensated for by suitable

capacities, so that the circuit may be in resonance for the frequency of the induced e.m.f., i.e.,

$$2\pi fL = \frac{I}{2\pi fC}$$

By thus employing tuned circuits, the magnitude of the current flow produced will be a maximum and is limited only by the effective resistance of the circuit. This effective resistance includes the losses due to hysteresis and eddy currents as well as dielectric losses.

Since e.m.f.'s of several frequencies are concerned, circuits must be available which are tuned to each of these frequencies. Fig. 21 indicates the arrangement employed by Goldschmidt, for a quadrupling of the generated frequency, direct current being supplied to the stator.

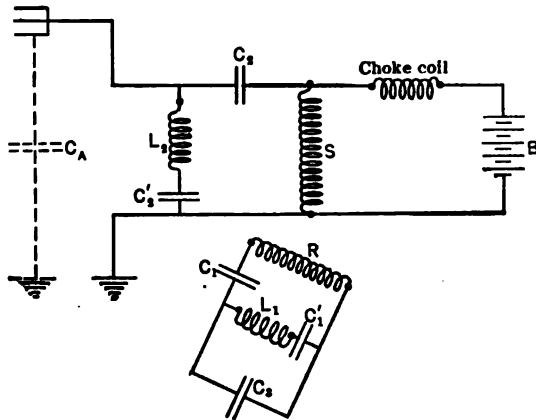

Fig. 21.—In order to get currents of appreciable amplitudes of the various frequencies generated in a “reflection” type machine the rotor and stator must be supplied with suitably tuned circuits, one for each frequency generated.

The rotor *R* revolves at the required speed in the d.c. field produced by the stator winding *S*, supplied by means of the storage battery *B*. There is thus induced in *R* an e.m.f. of frequency *N*, the value of which is given by

$$N = \frac{N_p \times RPM}{120} \text{ where } N_p = \text{the number of poles.}$$

This e.m.f. will cause a current of corresponding frequency to flow in the circuit *R*, *C*₁, *L*₁, *C*'₁, the values of the capacities and *L*₁ being adjusted so that the circuit is tuned to this frequency. *C*₁ compensates for the inductance of the rotor, while *L*₁ and *C*'₁ compensate each other, and the drop across them is thus very small. This current induces an e.m.f. of frequencies 2*N* and 0 in the stator circuit *S*, *C*₂, *L*₂, *C*'₂, in which the values of *C*₂, *L*₂ and *C*'₂ are adjusted to resonance for the frequency 2*N*. *C*₂ compensates for the inductance of the stator winding, while *L*₂ and *C*'₂ compensate each other, and therefore practically no drop exists across this portion of the circuit. The double-frequency current induces an e.m.f. of frequencies 3*N* and *N* in the rotor, and triple-frequency current

flows in the circuit R, C_1, C_3 , which is tuned to resonance for this frequency. Practically no current of frequency N will pass through C_3 , since L_1, C_1 , represents almost a short circuit path across C_3 for this frequency.

The triple-frequency current flowing in the rotor circuit R, C_1, C_3 , induces in the stator e.m.f.'s of frequencies $4N$ and $2N$, and currents of corresponding frequencies flow in the circuits S, C_2, C_4 and S, C_2, L_2, C_2 , respectively, each of which are tuned to resonance. The condenser C_4 represents the antenna through which we thus have a current flowing whose frequency is four times the frequency (N) of the current initially generated. If it were desired to utilize the triple-frequency current, the antenna would be connected to the rotor in place of C_3 , while L_2 and C_2 could be omitted from the stator circuit. By suitably arranging other circuits higher frequencies could be obtained but such an arrangement is not employed to any extent commercially, as the quadruple-frequency machine is more efficient and fulfills all requirements.

For the complete Goldschmidt machine as described in the preceding discussion, we may tabulate the generated frequencies, as before—

Stator	Rotor
0	N
$2N$ and 0	$3N$ and N
$4N$ and $2N$	

An exact analysis of all the actions in this machine is complicated and would be out of place here. The amplitudes of the various frequencies, it must be pointed out, however, are not the same; for all e.m.f.'s of zero frequency the amplitude is zero, while the other amplitudes depend for their values upon the tightness of the magnetic coupling between the rotor and stator circuits.

A fairly good idea of this reflecting action may be obtained by examination of the cut in Fig. 22 which shows the stator and rotor currents of a single-phase induction motor excited by a 60-cycle supply and running near synchronous speed. The rotor current evidently shows the two frequencies $(f + f')$ and $(f - f')$, f being the impressed frequency and f' the frequency of rotation. The rotor circuit and stator circuit were not tuned, otherwise more frequencies might have been accentuated, and the stator current would, for example, show $f + 2f'$ and $f - 2f'$ frequencies.

In Fig. 22 is shown the effect of running the rotor at practically synchronous speed. Here the amplitude of the differential frequency $(f - f')$ is so small that the film does not show it, although it can be seen from the film that the rotor frequency is slightly more than twice the stator frequency.

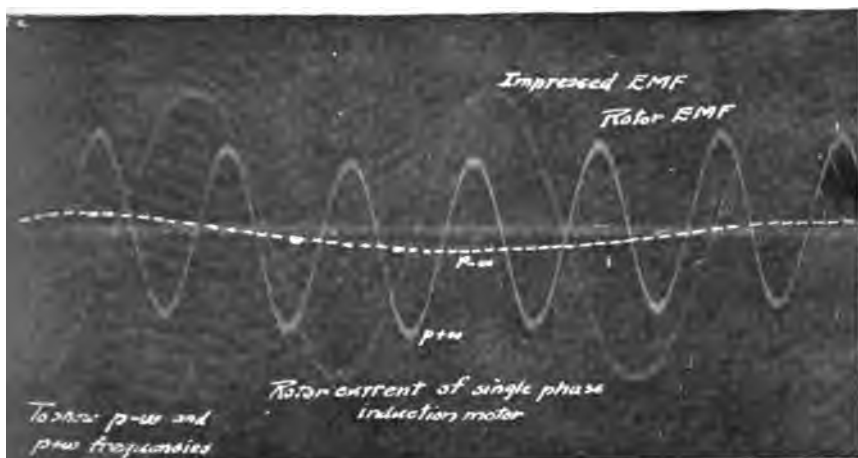

FIG. 22.—Rotor and stator e.m.f.'s of a single-phase induction motor. The rotor e.m.f. may be separated into its two components as shown by the dashed line. One frequency is equal to that impressed on the stator plus the frequency of rotation and the other frequency is the difference of the two.

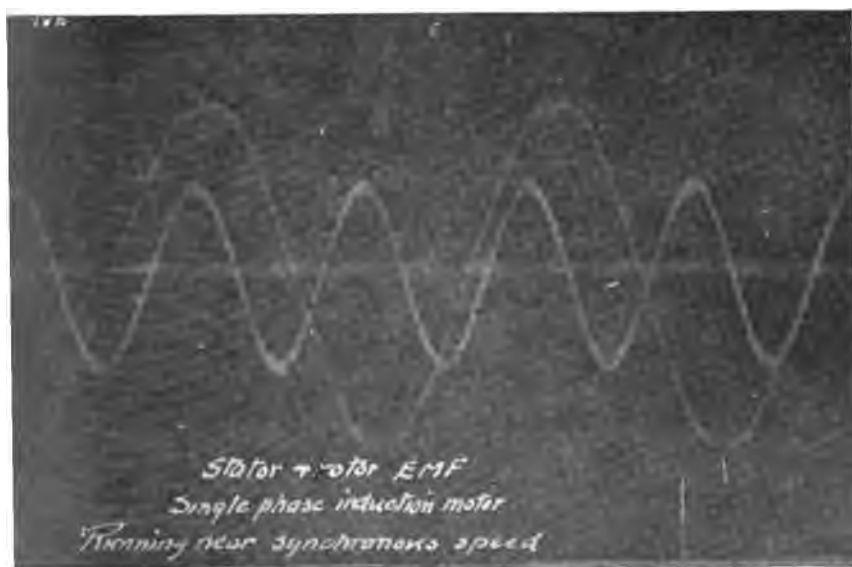

FIG. 23.—When the rotor was run at practically synchronous speed the amplitude of the differential frequency was practically zero, leaving in the rotor only the additive frequency.

Construction.—If we assume a required frequency of 40,000 cycles per second, and a frequency transformation ratio of 4, the initial frequency generated is 10,000. From the general equation for frequency

$$f = \frac{\text{No. of poles} \times \text{r.p.m.}}{120}$$

it is readily seen that a large number of poles will be necessary. Assuming a maximum desirable speed of 3000 r.p.m., we have

$$\text{No. of poles} = \frac{120 \times 10,000}{3000} = 400.$$

Considering a maximum safe peripheral speed of 200 meters per second, we obtain 1.25 meters as the maximum diameter permissible for the rotor. This gives a circumference of 400 cm., and thus the space available per pole is 1 cm. The windings are therefore laid out similar to the armature winding of the Alexanderson machine, and consist on both rotor and stator (the windings are identical) of the simple zig-zag winding shown in Fig. 24. The windings are split up into sections which can be connected

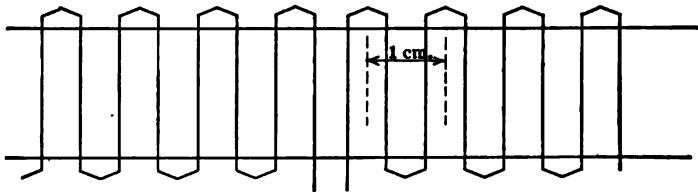

FIG. 24.—Developed winding of a Goldschmidt alternator.

in series or parallel arrangement to secure the most suitable voltage for the resistance of the antenna used. The conductor is made up of a number of very fine strands, about No. 40 A. W. G., each insulated individually to reduce skin effect.

To reduce the iron losses, the rotor and stator are constructed of very thin laminations of high-resistance iron. These laminations are .05 millimeter in thickness and are separated by paper about .03 millimeter thick. When the assembled material is compressed the volume of paper is more than one-third the total volume. To further decrease the iron losses, the iron is worked at low densities.

It is evident from the foregoing discussion on the action of this machine, that the air gap must be made as small as possible so that the magnetic leakage between the two windings shall be a minimum, since the induced voltages decrease for each succeeding reflection, this decrease being fixed by the amount of magnetic leakage and the losses. Excessive magnetic leakage also tends to prevent neutralization of the intermediate currents

and thus additional losses are caused which may be minimized by reducing the gap.

On the largest machines we thus find extremely small air gaps, being about .08 cm. on a 100 kw. machine (normal rating). The rotor of this machine weighs about 5 tons and is 1.25 meters in diameter, which indicates the extreme precision and care required for the proper construction of this type of generator. Trouble may be experienced if the rotor expands under the effects of temperature rise produced by continuous operation. This will cause an increasing output (almost inversely proportional to the gap length) as the gap decreases until the rotor suddenly makes contact with the stator and jams tight, resulting in the destruction of the machine.

It is also important that the rotor and stator slots be strictly parallel to the shaft and to each other. That is, there should be no skewing, as otherwise the e.m.f.'s induced throughout the length of one conductor of the winding will not be in the same phase, and a decreased voltage (and thus a decreased output) results. A divergence of 1 millimeter in 1 meter length would cause a decrease of 20 per cent in the total output.

Typical Installation.—The largest alternators of this type have a maximum output of 200 kw. with a normal output of 100 kw., one of which is located at Hanover, Germany, the other at Tuckerton, N. J. These machines are of the four-reflection type, with direct-current supply to the stator and having 400 poles. For an output frequency of 50,000, which means an initial frequency of 12,500, the motor drives the generator at 3750 r.p.m. This motor is rated at 4000 r.p.m., 250 h.p., 220 volts, and is supplied from two direct-current generators in Ward Leonard connection, to secure the necessary flexibility of speed control and ease of starting. The generator is directly connected to this motor by means of a flexible coupling.

The antenna at the Hanover Station consists of a double-cone system, the aerial wires being supported by a single steel tower 250 meters high. The aerial system is made up of 36 bronze cables of 8 mm. diameter, the outer ends of these cables being attached through insulators to poles 12 meters high which are arranged in a circle around the tower, the radius of this circle being about 450 meters. The tower is insulated at the base and half way up by means of heavy glass insulators and in addition is supported by steel guy wires, sectioned by insulators.

Frequency Transformation.—The design and construction of such alternators as described above, which provide at their terminals, e.m.f.'s of frequency sufficiently high to be used directly for radio-transmission, requires the highest type of engineering skill if the many complex problems involved in their construction are to be solved successfully. Alternators of somewhat lower frequency, however, say 10,000 cycles per second, can be

built with comparative ease with consequent reduction in initial cost, and increased reliability of operation. Therefore instead of using the high-frequency alternator directly supplying the antenna circuit, we may substitute a lower-frequency machine, and step-up the frequency to the required value by means of a frequency changer or transformer. Efficient frequency transformation thus presents a means for supplying undamped radio-frequency current, and the action of some of the various frequency changers which have been proposed for this purpose are therefore of interest.

Types of Frequency Changers.—Frequency changers may be static, constructed similarly to the ordinary modern power transformer, or may contain a revolving element. In the latter type, utilizing one rotor winding and one stator winding, the frequency is raised by electrical reflections, four, five, or even higher transformations being accomplished. This type is illustrated by the Goldschmidt machine as described above, which may thus be considered as a generator and frequency changer in one, as it generates a current of frequency N , and this initial frequency is then transformed to some higher frequency at the output terminals.

The simplest type of frequency changer utilizing a rotating element is illustrated by the large-capacity frequency changers used for the interchange of power between systems of different frequencies as for instance, a 25 and a 62½ cycles system. The machine consists of two rotors and two stators, the rotors being mounted on a common shaft, the one element operating as a synchronous motor and the other as an alternator, and vice versa, depending on the direction of energy flow. By means of apparatus of this type it is thus possible to transform a commercial frequency supply of 25 cycles to a frequency of 10,000, or less, which may be further transformed by one of the static transformers described below.

Many forms of the static type of frequency changer have been suggested, differing mainly in the manner of their connections, and the number of frequency transformations. Thus there are frequency doublers and triplers, which may be further connected in cascade, resulting in additional increase of frequency. Fundamentally, nearly all of them operate on the same phenomenon, namely, the asymmetrical variation of flux with magnetizing force in saturated iron cores. The explanations to be given below will consider only this feature of the circuit although a rigid analysis would undoubtedly require an investigation of the variation in resistance throughout the cycle, as well as these peculiar flux changes.

Joly Frequency Tripler.—In the Joly frequency tripler illustrated in Fig. 25. The primaries are joined in series, and the turns and core dimensions in the two transformers are so proportioned that B is saturated at about one-half the current value required to saturate A . Thus, if we assume a sine wave of voltage E supplied by the alternator, we can plot

this voltage and the total flux ϕ , which must be developed in the two transformers to develop the required c.e.m.f., as shown in Fig. 26A.

Since the total flux ϕ is a maximum when the primary current is a maximum, the component fluxes, which exist in each transformer, and which add up to give this total flux, must each be a maximum at this instant. Since *B* saturates at about one-half the current value required for *A*, we can plot the component fluxes as shown in Fig. 26B.

The primary current, which has not been indicated, is approximately sinusoidal in form. The two fluxes ϕ_a and ϕ_b , by their variation cause e.m.f.'s E_{a2} and E_{b2} to be induced in their respective secondary windings, the wave form of these e.m.f.'s being indicated in Fig. 26C.

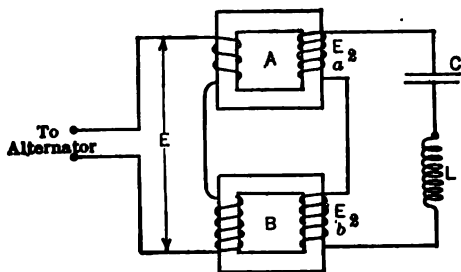

FIG. 25.—Use of two saturated arcs to triple the frequency.

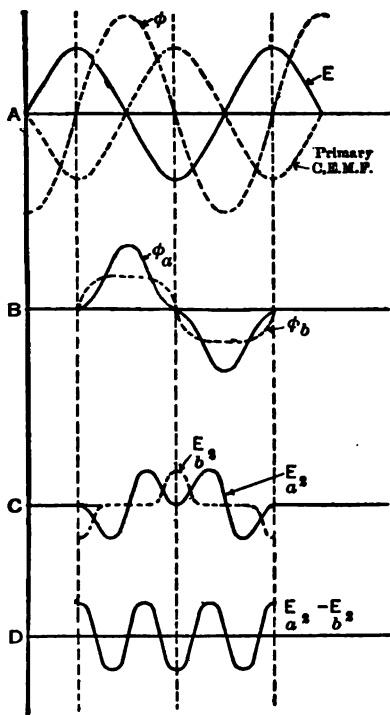

FIG. 26.—Analysis of action of the arrangement of Fig. 25.

The two secondary windings are so connected together that the voltage across the load circuit ($L-C$, Fig. 25) is obtained by taking the difference of E_{a2} and E_{b2} ; in Fig. 26D this line voltage ($E_{a2} - E_{b2}$) is shown and it is evident that the e.m.f. is principally a triple-frequency one. The load circuit, which includes the radiating antenna and its loading coil (if any), must be tuned to this triple-frequency e.m.f., if an appreciable output is to be obtained.

Frequency Doubler.—An arrangement for doubling the frequency first suggested by Epstein in 1902 and subsequently developed by Joly and Vallouri, is indicated in Fig. 27. Both transformers are identical, and each is equipped with a tertiary circuit, supplied from the storage battery *B*.

is equipped with a tertiary circuit, supplied from the storage battery *B*.

The steady current flowing through these windings is adjusted to bring the transformer fluxes just to the point where saturation occurs, i.e., at the knee of the curve as indicated in curve *A*, Fig. 27. If the two primaries, in series, are connected to an a.c. supply, it may readily be seen from the figures, that on a positive half cycle the flux in T_1 (wherein the m.m.f. of the primary winding assists the d.c. winding), will change very little, while the flux in T_2 will decrease considerably, since the primary m.m.f. opposes the m.m.f. of the d.c. winding. On the negative half cycle, the reverse is true. These conditions are indicated in Fig. 28, *A* and *B*. It should be noted that an asymmetrical variation of flux thus occurs in each transformer, the flux of one transformer having a large variation during one alternation while the flux of the other transformer changes only slightly and on the next alternation, these conditions are reversed. These fluxes

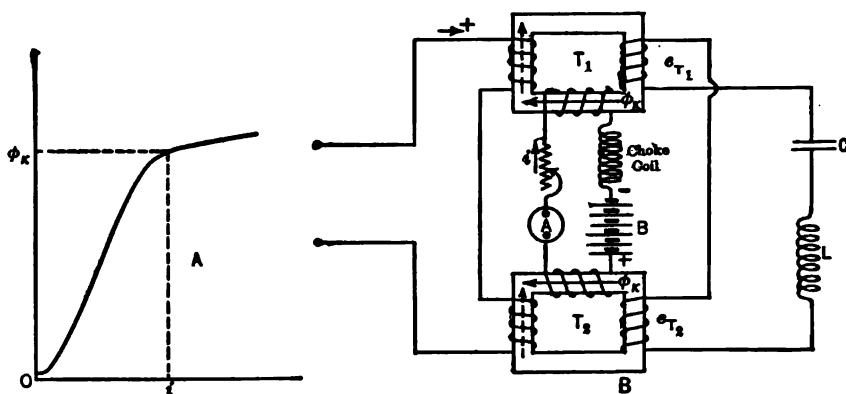

FIG. 27.—Use of two saturated cores for frequency doubling.

exist in separate cores and do not combine to form a double frequency flux. The e.m.f.'s which they induce in their respective secondary windings are indicated in Fig. 28*C*, and since the secondaries have been connected reversed with respect to each other, the difference of the voltages must be taken to obtain their resultant. This is indicated in Fig. 28*D*.

This method for obtaining a doubling of the initial frequency has found some commercial application to high-frequency work, having been developed by Count von Arco for the Telefunken Company, and known as the Joly-Arc System. It is employed at the U. S. Radio Station at Sayville, Long Island, for doubling an initial frequency of 15,000.¹

Plohl's Frequency Doubler.—An interesting circuit, applying these principles, as suggested by Plohl, is indicated in Fig. 29. The action of this circuit will be evident from the connections and the curves shown

¹ Bucher, "Practical Wireless Telegraphy," p. 273.

in Fig. 30. Essentially, the chokers R_1 and R_2 act as magnetic valves, each absorbing the impressed e.m.f. almost completely on alternating half cycles, while offering very little impedance, due to saturation effects, during the other half cycle. Thus a flux will alternately be produced by P_1 and P_2 and since they are wound in reverse relationship, this flux will always be in the same direction, through the core of T as shown in Fig. 30C. A double-frequency voltage is thus induced in the secondary winding, as indicated in Fig. 30D.

Taylor's Frequency Tripler.

—An arrangement for tripling the initial frequency of a three-phase supply, as developed by A. M. Taylor, is indicated in Fig. 31.

The three chokers R_1 , R_2 , and R_3 are saturated early in the cycle, at a relatively low value of current, while the core of the transformer T remains unsaturated at all times. Considering one of the elements, for instance that between a and b , and assuming a sine wave of voltage, the voltage and flux conditions which must exist are as indicated in Fig. 32A. (Fig. 31A indicates the circuit detail under analysis.) As the primary current increases, a point is reached where the choker becomes saturated. When this occurs, the impedance of the circuit decreases

materially, and the primary current increases rapidly, as indicated by the current curve (Fig. 32B). This causes very little change in the choker flux, which has already reached saturation, but does cause a variation in the transformer flux. The transformer flux, although varying proportionately to the primary current I , does not reach large amplitudes, since

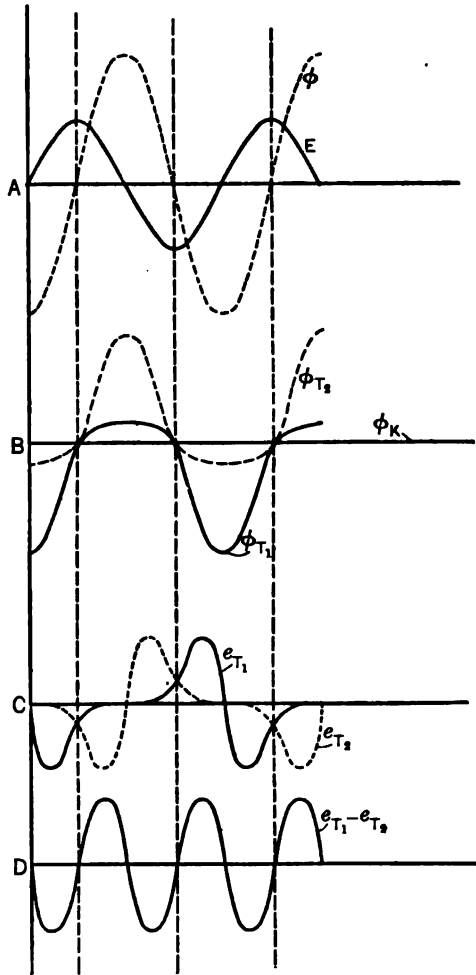

FIG. 28.—Analysis of the action of the arrangement of Fig. 27. The flux ϕ_{T2} in curves B B is shown in reversed phase.

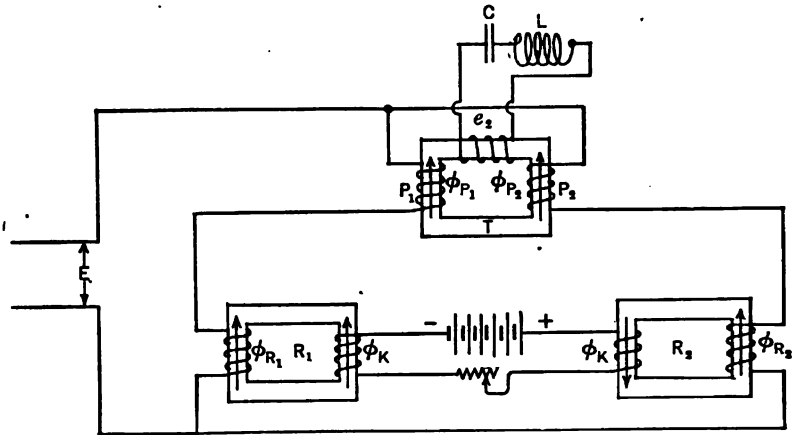

FIG. 29.—Another type of frequency doubler.

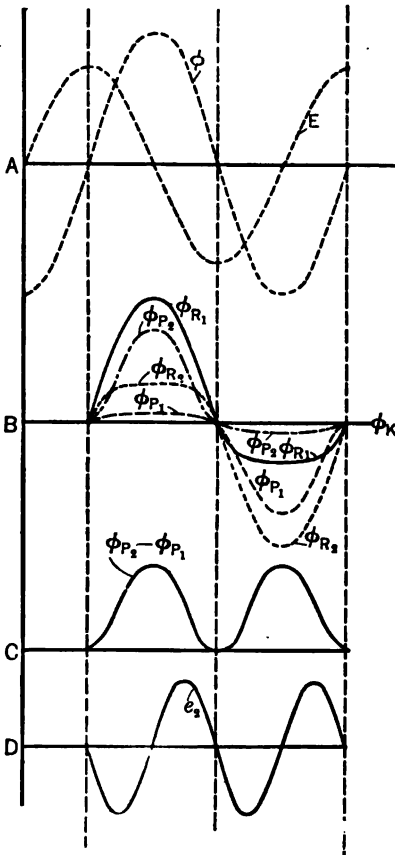

FIG. 30.—Curves showing action of apparatus shown in Fig. 29.

most of the flux required to produce the proper sine wave of counter e.m.f. is already existent in the core of the choker. The choker and transformer flux must add to give a resultant equal to the sine wave of flux shown in Fig. 32A, based on the assumed sine voltage. The transformer flux will induce in the secondary a voltage the form of which is shown in 32C. A similar e.m.f. wave will be induced by each of the other two phases in exactly the same way as outlined above.

The voltages e_{bc} and e_{ca} will differ in phase from e_{ab} by 120° and 240° (electrical degrees), respectively, as the primary supply voltages E_{ab} , E_{bc} , E_{ca} differ in phase from one another by this amount. These three induced voltages e_{ab} , e_{bc} , e_{ca} , exist simultaneously in the secondary winding of T and thus add up to give the resultant triple-frequency voltage indicated in 32D. It would be possible to employ nine chokers, and a nine-phase supply, to produce a nine-fold transforma-

tion, if this were desirable. In this case a sine-wave alternator could not be used, due to interference effects in the high-frequency circuits, and a machine of special design would be required.

Losses of Static Frequency Changers.—The above methods of frequency transformation which utilize static transformers possess the disadvantage of excessive iron losses, even though special precautions are taken in the construction of the iron cores, as at the higher frequencies these losses are very large; dielectric losses in the insulation may also be excessive. Probably the most practical would be the Joly arrangement for doubling the frequency, using two of these doublers in cascade to quadruple the frequency, and making the delivered energy thus suit-

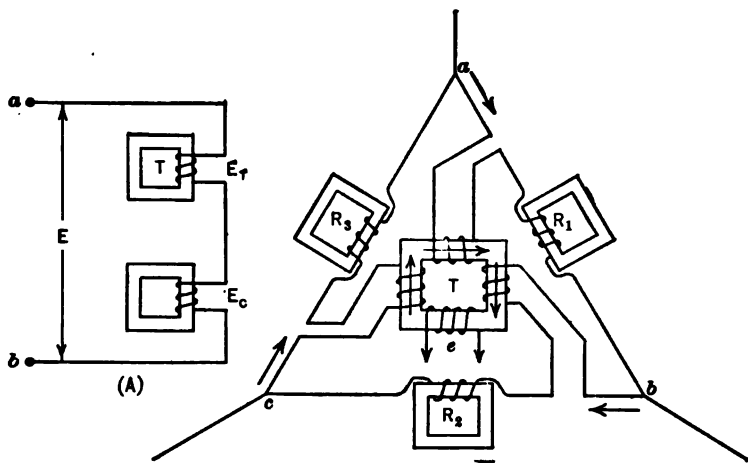

FIG. 31.—A frequency tripler, working from a three phase supply.

able to the requirements of radio telegraphy and telephony. With every arrangement it is highly important that the secondary circuit be tuned to the desired upper harmonic, as otherwise the higher-frequency current will be relatively small and current of fundamental frequency will probably predominate.

The "Wabbling Neutral" as a Means of Tripling the Alternator Frequency.—It is a well-known fact that the line currents of a 3-phase system are 120° out of phase and their algebraic sum is equal to zero. Their third harmonics differ therefore by $3 \times 120^\circ$, or 360° , i.e., a complete period, and are in phase with each other. Since, in all cases, the instantaneous (algebraic) sum of the alternator currents must be zero,¹ it is evidently impossible for the line currents to contain third harmonics. If we impress a sine wave of voltage on three Y-connected transformers

¹ Delta-connected load assumed, or if Y-connected, the neutral point of the load is supposed ungrounded.

(their secondaries being open-circuited, and hence not shown in Fig. 33 as they can have no effect when open), the third harmonic component, which normally predominates in the exciting current of an iron-core transformer, is suppressed, and the magnetizing current is a sine wave.

The line voltages are sine waves, but the voltage to neutral must contain a strong third harmonic, due to the suppression of the third harmonic component in the exciting current, which must be present if the c.e.m.f. is to be a sine wave. Therefore, the wave of magnetization cannot be of sine form, but will be flat topped (somewhat as indicated in Fig. 34, curves 1, 2, and 3) due to the saturation of the iron. The induced e.m.f.'s will thus have the wave form indicated, and may be resolved into their fundamental and

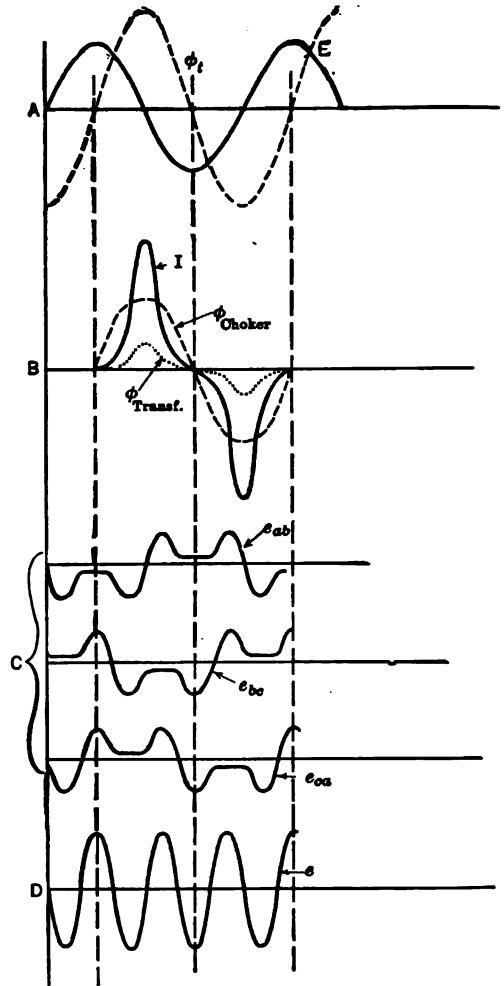

FIG. 32.—Curves of flux and e.m.f. explaining the action of the apparatus shown in Fig. 31.

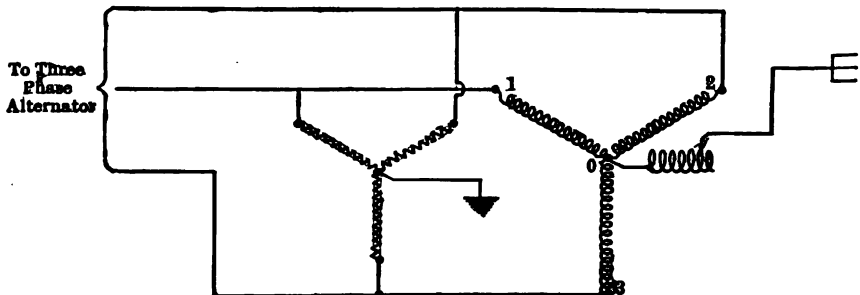

FIG. 33.—The "wabbling neutral" scheme of tripling frequency; the center point of 3 Y-connected iron core coils is connected to the antenna and the center point of 3 Y-connected air core coils is connected to ground. The three-phase power supply is otherwise ungrounded.

third harmonic components as shown in curves 4, 5, and 6. It will be noted that the third harmonic components in all three phases are in phase. Thus the potential of point 0, Fig. 33, will fluctuate at triple frequency as shown in curve 7 of Fig. 34. This triple frequency e.m.f. may be impressed on an antenna circuit as shown in Fig. 33.

The voltages indicated in the above curves exist across the transformer windings, and add up to give a sine wave of c.e.m.f. at the line terminals. This is shown in curve 8, wherein the third harmonic potentials neutralize one another, only the fundamental components combining. This curve is evidently a sine wave, which is as it should be, if it is to neutralize the impressed voltage, which has been assumed as a sine wave.

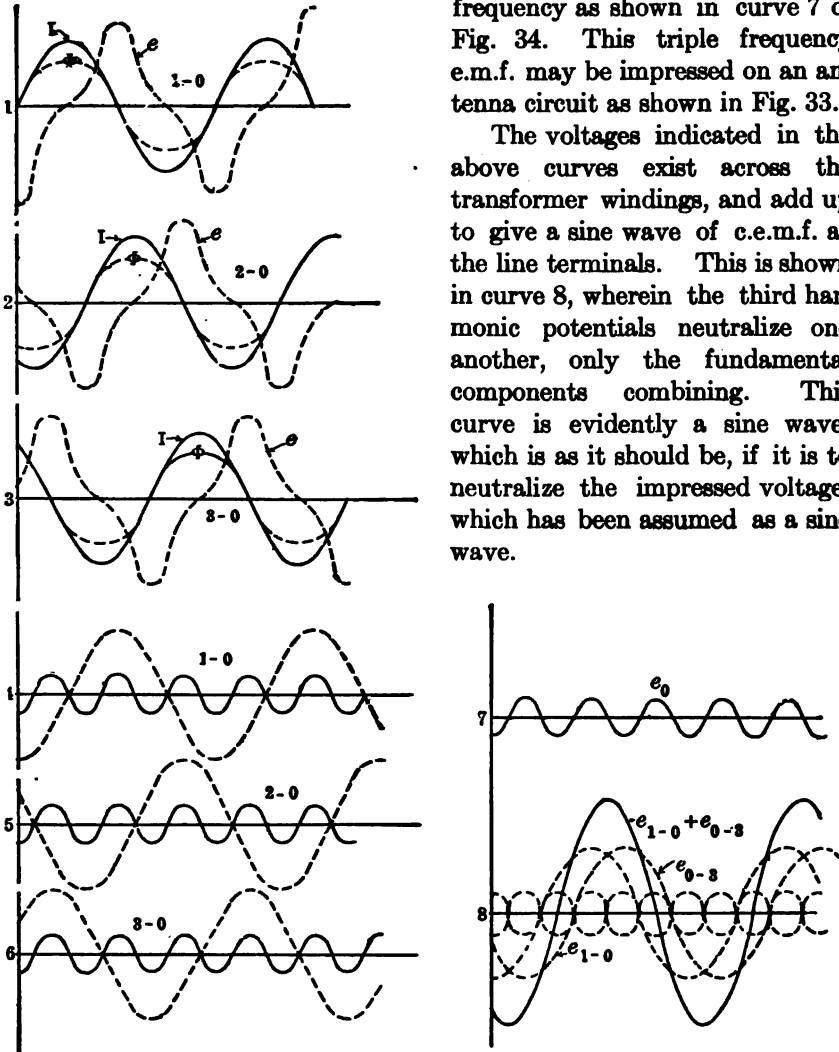

FIG. 34.—Curves of flux and e.m.f. to analyze the action of the wobbling neutral; in curves 8 the voltage forms e_{0-1} and e_{0-2} are shown without their third harmonics, these being shown separately in the X axis.

In Fig. 35 is shown an oscillograph record of this scheme of frequency conversion; three transformer primaries (secondaries open) were connected in Y to a three-phase power line and another Y connection was made

with three air-core coils. The two neutrals were then connected together and the resulting current in the connection was nearly a pure sine wave of triple frequency.

Application of Rectifier Elements to Frequency Changers.—Another type of frequency changer is that utilizing a rectifying element in the primary circuit. The action is due fundamentally to the fact that the flux in the iron core is always set up in the same direction, regardless of reversal of the supply current. Fig. 36 indicates a typical connection, while Fig. 37 indicates the voltage and flux relations obtained.

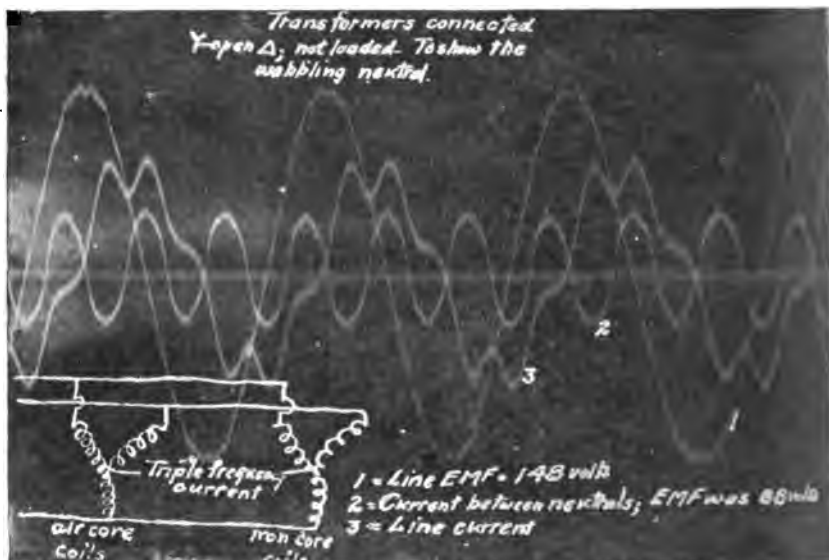

FIG. 35.—Oscillogram showing the third harmonic obtainable from the circuit of Fig. 33.

Fig. 38 indicates an arrangement utilized by Zenneck and others. This operates exactly similar to the arrangement of Fig. 36, but makes use of four valves to secure unidirectional current through the one primary winding. Current is permitted to flow only in the direction indicated by the arrows in the valve elements; an inspection of the figure will indicate their operation. Fig. 37 is also applicable to the operation of this circuit.

Marconi Multi-gap Generator.—By properly timing the discharge periods of related spark circuits, each circuit acting inductively on a common secondary circuit, undamped high-frequency oscillations may be obtained in the secondary circuit. This principle has been utilized by Marconi in the construction of a multi-gap generator, the connections of which are indicated in Fig. 39.

The synchronous gaps D_1, D_2, D_3 , etc., are all rigidly keyed to the same shaft, but are displaced properly with respect to one another so that the discharge in the several circuits occurs at different intervals. The result is graphically illustrated by the curves shown in Fig. 40. It is essential, for efficient operation is to be obtained, that the several circuits are discharged in proper sequence and at exactly the right instant, so that the component oscillations acting on the common antenna circuit will produce a constant amplitude high-frequency current as shown. This is accomplished by the proper displacement of the several disk discharges on the shaft and is also insured by means of an auxiliary disk resembling a toothed wheel, which acts as a "trigger" to cause the main discharge to occur at exactly the proper instant. This is not shown in the diagram.

It is evident that the speed of rotation of the discharger disks is fixed by the radio frequency generated and for this reason the generator is particularly adapted to long wave-lengths. If we assume a generator with ten disks, each having 40 studs, and the shaft revolved at 50 r.p.s. the interval between two condenser discharges is

$$\frac{1}{50} \times \frac{1}{40} \times \frac{1}{10} = \frac{1}{20,000} \text{ second.}$$

The radio frequency is, therefore, assuming the discharges to occur at one-cycle intervals, equal to 20,000 and the wave-length 15,000 meters. Similarly if the successive discharges occur at intervals of every other cycle, the frequency may be 40,000, corresponding to a wave-length of 7500 meters.

This generator is not used to any great extent, and a very brief treatment only, which is not complete, has therefore been given.

Oscillating Tubes.—Within the last few years many improvements in the design and construction of vacuum tubes have

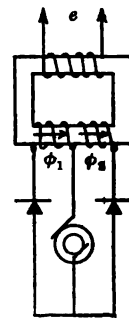

FIG. 36.—A frequency doubler using iron core and rectifiers.

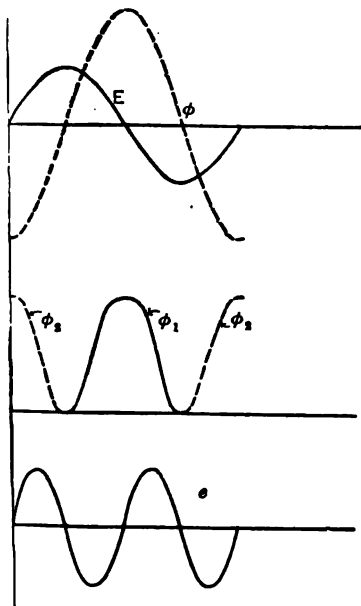

FIG. 37.—Voltage and flux relations for the circuit of Fig. 36.

been made and their applications are continually growing more varied and important. At the present time, however, the power obtainable from oscil-

lating tube circuits, as described in Chapter VI, is comparatively small. Their greatest field of use has therefore been confined to the reception of undamped wave signals (see p. 483), and to small power transmitting sets (of perhaps 1 kw. high-frequency output), such as might be employed for military service in the field, or any other service where light weight and small space requirements are primary considerations.

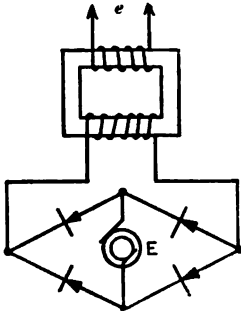

FIG. 38.—By using four rectifiers the double primary coil of Fig. 36 may be replaced by a single coil.

To secure the large amount of power required for long-distance transmission, it is necessary at the present time to connect a number of the tubes in parallel, and adjust the several circuits so that they operate properly. The limitation in output of one tube is due primarily to the inability of the tube to radiate the large amount of heat which is necessarily generated within the tube itself. As improvements in design and construction occur, under the extensive developments which are now being carried on, it may be expected that the rating of tubes will continually increase, so that eventually this device may replace the present forms of undamped wave generators. Oscillating tubes possess several advantages over all other high-frequency generators, principally: ease of adjustment and reliability of operation,

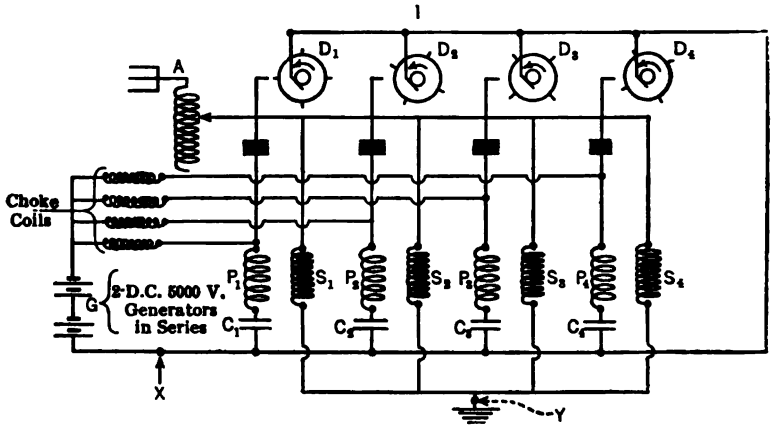

FIG. 39.—Marconi's "multi-gap" scheme for generating undamped waves from a series of spark discharges.

small space requirements, simplicity of construction and relatively high efficiency.

Some progress along the lines indicated above may already be recorded. Large tubes have been constructed having an *input* rating of 500 watts

and greater, while in England a steel tube equipped with a water-cooled plate and rated at 5 kw. has been developed.¹ The plate voltage of these high-power tubes is in the neighborhood of 5000 to 10000 volts, the plate current having a normal value of perhaps 0.25 ampere. The plates become very hot, while the tube is in service, in some cases approaching incandescence, and special metals are therefore required in its construction, tungsten usually being used.

In rating the tube by its energy input, as has been done above, the filament circuit supply has not been included. It should be noted that the external oscillating circuit connected to the tube must take its proper share of this input energy, or too much energy will be required to be dissipated from the tube, with resultant danger of overheating the tube elements. If for any reason the tube stops oscillating under conditions of full energy supply, the plate voltage should be immediately decreased to prevent any damage to the tube.

Probable Efficiencies of above Apparatus.—*Poulsen Arc.*—Assuming sine waves, a theoretical efficiency of 50 per cent is possible, but probably an actual arc does not give greater than 40 per cent. For instance, the cooling water of a certain 25 kw. arc carried away 14 kw. of heat. For arc oscillations of the third class (p. 587) efficiencies much greater than 50 per cent are conceivable, but as this type of oscillation is seldom used, we assume the efficiency of the normal arc less than 50 per cent.

Alexanderson Alternator.—No data are obtainable regarding the efficiency of the large Alexanderson alternators, but it seems likely that it is not better than 50 per cent. Examination of the construction of a modern machine shows the likelihood of high iron losses and the care taken to provide adequate cooling² facilities substantiates this idea.

¹ Since writing the above the author learns that tubes with an output of about 100 kw. have been put into operation.

² See Alexanderson, "Transatlantic Radio Communication." Proceedings A. I. E. E., Oct., 1919.

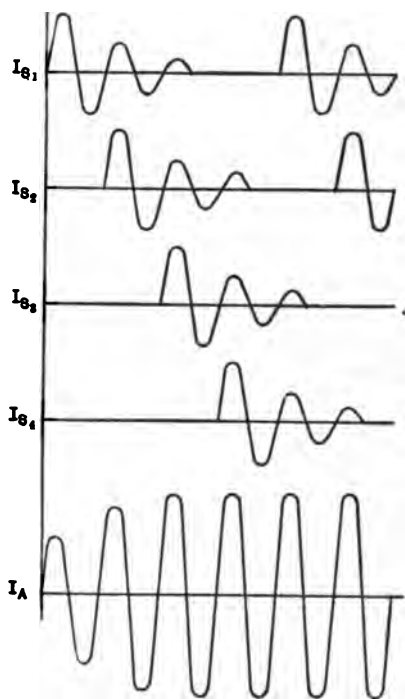

FIG. 40.—Spark discharge operation of the circuit of Fig. 39.

In the smaller sets, the efficiency may be extremely low: a 200,000-cycle machine, for example, having a maximum output of 500 watts, requires 10 h.p. driving motor. A large part of the motor output is apparently used in windage losses caused by the high rotative speeds.

Goldschmidt Alternator.—Although one would judge that the efficiency of this type of machine could not be very high, the great care taken in the construction of both the magnetic and electric circuits evidently keeps the losses as small as possible. It is stated by Eccles¹ that a 12½-kw. machine of this type (one of the first to be built) had an efficiency of 80 per cent.

Static Frequency Changers.—It is estimated by the inventor of one of these schemes using iron cores that a 28-kw. transformer will have an efficiency of about 86 per cent.² It seems that these devices use about 1 lb. of iron per kw. of output and an attempt to calculate the probable eddy current and hysteresis losses gives a value of perhaps 1 kw. per pound of core used, which would indicate an efficiency in the neighborhood of 50 per cent. It must be pointed out, however, that attempts to calculate the core loss from the ordinary formulæ are probably inaccurate, because of the peculiar magnetic cycles to which the iron is subjected.

Marconi Multi-gap Generator.—This method is essentially a combination of several spark transmitters, and so should have about the same efficiency as a spark transmitter. This will vary with the condition of the gap, its quenching action, etc., but probably reaches a value of 70 per cent in the larger installations. For a small transmitter, an efficiency of transformation from low to high frequency of 40 per cent is more likely.

Oscillating Tube.—The efficiency of an oscillating tube varies a great deal with the adjustments of the circuit, and may have any value between 25 per cent and 95 per cent, neglecting the amount of power used for heating the filament. This point is discussed in detail in Chapter VI, p. 539 et seq.

Methods of Signaling with Continuous-wave Transmitters.—The generators described above will supply a continuous-power input to the antenna circuit and with no changes in the antenna or supply circuit, a continuous undamped high-frequency current will flow through the antenna. The power radiation from the transmitter is therefore constant in magnitude and frequency. Three methods may be utilized for varying this radiated energy in accordance with a prearranged code, and thus transmit intelligence to the distant receiving station. The three methods of sending may be stated as follows:

¹ See Eccles, "Wireless Telegraphy and Telephony," p. 230.

² *Ibid.*, p. 235.

1. The total interruption of energy radiation during a "space." This is known as the "cut-in" method.

2. Continuous radiation of energy throughout the sending of a message, the space and signal differing only in the wave-lengths at which the energy is transmitted. This is called the "compensated" method.

3. The total interruption of energy radiation during a space period, with the radiation rapidly interrupted by means of a chopper or interrupter during the signal period. This is known as the "modulated" method of sending, and possesses advantages under certain emergency conditions as described later.

The high-frequency current flowing in the transmitter antenna for each of three methods of sending is indicated in Fig. 41.

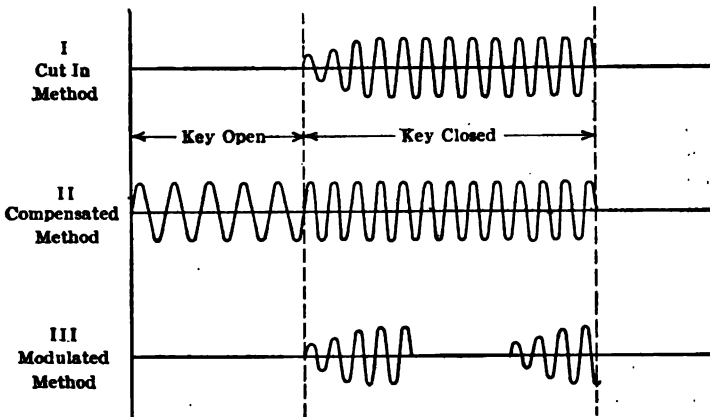

FIG. 41.—Methods of transmitting signals from continuous wave stations.

Signaling Devices.—For transmitting by means of the above methods one of the following devices may be used, depending on the type of generator used.

- I. Chopper or buzzer (choice will depend on the amount of current to be interrupted.)
- II. Wave-length changing switch.
- III. Switching to dummy antenna.
- IV. Control of excitation of machine.

The application of these devices to the several types of high-frequency generators, previously described, will now be considered.

Methods of Sending Applicable to the Poulsen Arc Generator.—This generator depends for its operation on an uninterrupted supply to the arc and the antenna circuit (which is the sole natural-frequency circuit of the transmitter). Therefore the means indicated under II and III

only can be applied, namely, changing the wave-length or switching to a dummy antenna. A change in wave-length may be secured by simply

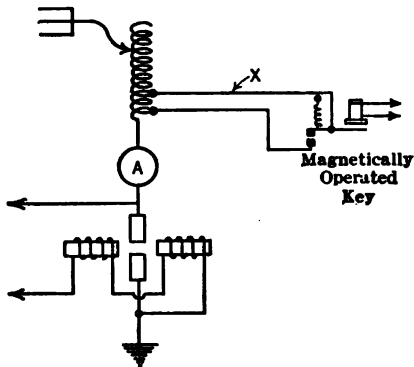

FIG. 42.—The ordinary method of signaling with a Poulsen arc; by short-circuiting a small part of the loading coil the wave length radiated is changed slightly and with a suitable receiving circuit the signal becomes audible.

attempted to operate it manually. Sometimes, instead of short-circuiting a turn of the antenna load coil, an independent circuit of one or two turns, connected to the antenna load coil by mutual induction, is short-circuited by the relay key.

The connections for utilizing a dummy antenna are shown in Fig. 43. In this case the key simply acts to transfer the arc circuit to the radiating antenna when it is desired to send a signal. At other times the arc supplies the dummy antenna and no energy is radiated. The energy radiation would thus be as shown in Method I, Fig. 41.

This method is relatively little used, but illustrates the application of switching to a dummy antenna to secure "cut-in" radiation. The constants of the dummy circuit should be identical with the constants of the radiating antenna circuit, so that the conditions at the arc are constant.

Referring to Fig. 42, we may place an interrupter or chopper at *X*,

connecting the transmitting key so as to short-circuit one or more turns of the antenna inductance when a signal is being transmitted, as indicated in Fig. 42, and to cut in these turns during the space interval.

This arrangement is practically universal on present arc installations. On the higher power sets, the key does not directly short circuit the inductance, but operates an auxiliary relay, which in turn actuates the solenoid-operated contactor at the coil. This is required due to the heavy current which must be broken, and rapid signaling would be impossible with the heavy and massive key required if it were

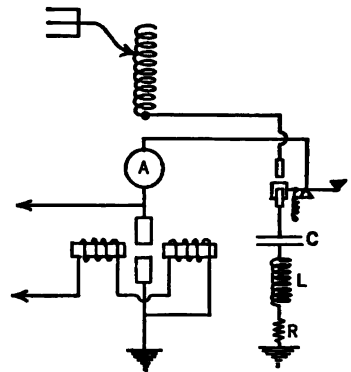

FIG. 43.—Another scheme which has been tried with the Poulsen arc is to switch the arc to a dummy antenna.

and thus secure a combination of methods II and III. The antenna current would then have the form indicated in Fig. 44.

Methods of Sending Applicable to the High-frequency Alternator.—With this generator the frequency is fixed by the speed of the machine.

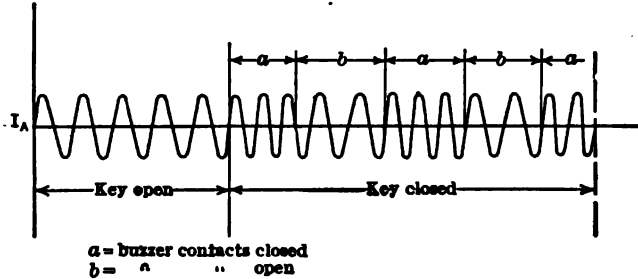

FIG. 44.—A possible type of radiation from a Poulsen arc using the circuit of Fig. 42, with an interrupter of some kind at X.

Therefore, transmission by Method II cannot be used (a variation in antenna inductance simply causing a decrease in the amplitude of the antenna current), but Methods I, and III, are applicable, the former usually being used.

Signaling is most easily accomplished, however, by control of the excitation, which may simply involve a key in the generator field circuit as indicated in Fig. 45. A resistance, may, with advantage, be inserted in the field circuit, to decrease the time constant ($\frac{L}{R}$) of the circuit and minimize any tendency toward sluggishness which may prevent the signals from being clean cut and distinct, and thus limiting the sending speed.

A method has also been developed to control the radiated energy by means of a shunting circuit across the alternator terminals, the impedance of this circuit being controlled by the sending key. The connections are indicated in Fig. 46. When the key is raised (contacts closed) the current flowing through L_2 saturates the iron cores $a a$, and the reactance of L_1 decreases accordingly. This effectively spoils the tuning of the alternator load circuit and hence brings the alternator output to practically zero.

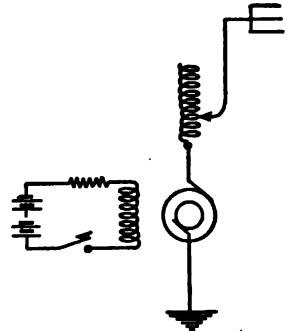

FIG. 45.—The simplest possible transmitting scheme using a high-frequency alternator.

When the core is saturated, the impedance of the shunt circuit is so low as to amount almost to a short circuit on the alternator, under which

condition the alternator voltage is very small and is able to send but very little current through the antenna circuit. Therefore the radiated energy will decrease to a very small value, essentially zero. When the key is depressed (open position), the iron is no longer saturated and the impedance of L_1 increases to a high value. The alternator current will then flow through the antenna circuit in preference to the shunt circuit, and energy will be radiated.

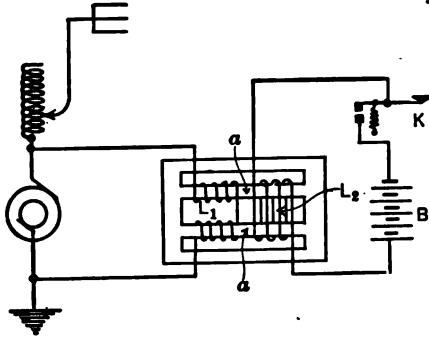

FIG. 46.—A method of sending by generator which employs a magnetically controlled short-circuit on the machine.

At the New Brunswick station this variable, iron-cored impedance is connected in a tuned circuit (tuned when the key is open) which is coupled to the antenna and alternator as shown in Fig. 47. When the key is closed, the local circuit is detuned and the energy input into this

circuit becomes very small, the major portion of the energy thus being diverted to the antenna circuit. The transformer indicated in the figure is an integral part of the alternator and is shown supported in two sections above and on either side of the alternator in Fig. 17, p. 599.

For either scheme of control, the energy radiation is essentially as shown in Fig. 41-I. The use of a chopper or buzzer in the exciter circuit may not be entirely satisfactory, due to the inability of the machine voltage to follow accurately the rapid variations of field current produced. There is no doubt, however, that satisfactory results could be obtained by inserting the interrupter in the key circuit of Fig. 47. Radiation in this case would be nearly as indicated in Fig. 41-III.

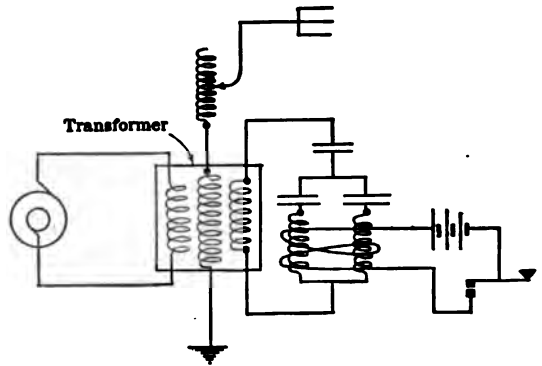

FIG. 47.—In the application of the scheme indicated in Fig. 46 it is found advisable to use the circuit arrangement shown above.

Methods of Sending Applicable to the Goldschmidt Alternator.—As with the Alexanderson alternator, the generated frequency for this machine

is fixed by its speed, and therefore wave-changing methods are not applicable. Signaling is accomplished by means of the "cut-in" method using field excitation control, the connections are indicated in Fig. 48. In addition to opening and closing the exciter circuit, the key also simultaneously cuts out or in a portion of the driving motor field resistance. Thus, any tendency of the alternator to suffer a drop in speed, when the exciter

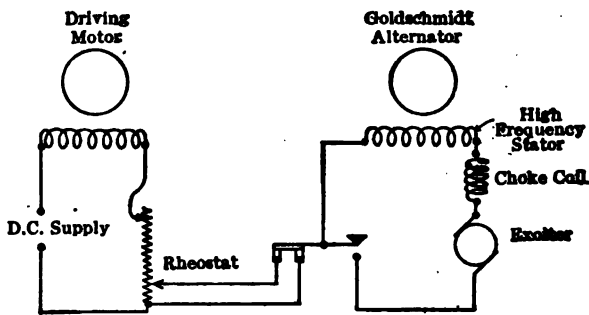

FIG. 48.—Scheme of sending signals with the Goldschmidt alternator using a motor speed control in addition.

operating conditions the variation in wave-length is claimed to be less than one-tenth of 1 per cent.

The above discussion describes the only method which has yet been used for controlling the output of this alternator. Switching to a dummy antenna, or some form of shunt circuit, as described for the Alexanderson machine, would also be applicable, but the present method seems to be completely satisfactory.

Methods of Sending which May be Used when Frequency Transformers are Used.—Since these transformers must be associated with some form of high-frequency alternator, whose frequency is rigidly fixed by its speed, the same methods as described above for the Alexanderson and Goldschmidt machines will apply. On low-power sets the key may be connected to open the supply circuit directly, while on large-power sets the circuit may be opened indirectly by auxiliary relays actuated by the sending key. The antenna current would then be as shown in Fig. 41-I. The key may also have associated with it some form of interrupter or chopper, resulting in current variation as shown in Fig. 41-III.

For the larger installations, the energy would be controlled by means of the exciter supply due to the smaller power involved. Cut-in sending would be the most feasible, although switching to a dummy antenna or connecting a variable impedance across the alternator terminals as in the case of the Alexanderson machine could also be used.

Energy Radiation Control when Marconi Generator is Used.—For a generator of this type, switching to a dummy antenna would be a satis-

factory means of varying the radiated energy, the "cut-in" method of sending thus being used. Some form of absorbing circuit across the generator terminals might also be used to give similar results. The key might be placed in the common generator lead at point *X*, Fig. 39, p. 618, or point *Y*, opening the supply or antenna circuit respectively. An interrupter element may be associated with either of these three means, giving the "modulated" method of sending as shown in Fig. 41-III. It would be undesirable to employ a wave-changing scheme, as this would require circuit variations in each of the four primary circuits involved, with resultant complexity of connections, etc. On larger installations, it would be preferable to place the key in the exciter circuit of the d.c. generators, in preference to the point *X*. This would probably be the most satisfactory means of control for the same reasons as stated above in connection with high-frequency alternator installations.

Control of Radiated Energy when the Oscillating-tube Generator is Used.—The radiation of energy from an antenna supplied from an oscillating-tube generator may be in accordance with any one of the three methods indicated in Fig. 41. The method employed for small sets is usually a direct opening of the antenna circuit by means of the key, which may or may not be associated with an interrupter (usually a buzzer for small field sets) to obtain the modulated method of sending.

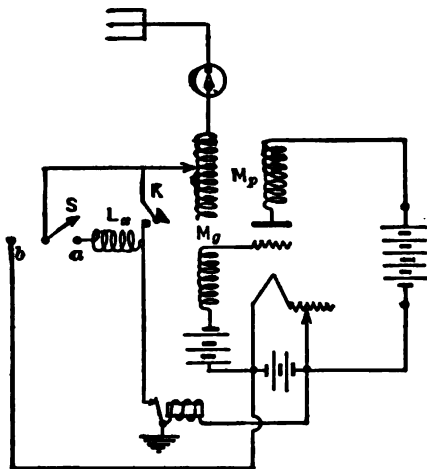

FIG. 49.—An arrangement whereby the output of this small tube transmitter can be controlled by either one of three methods.

The wave-length change may be obtained by short circuiting a portion of the antenna circuit inductance. Since the power generated by these circuits is as yet comparatively small, there is no necessity for auxiliary relay equipment to be associated with the key. The most feasible control scheme, however, is one which controls the "grid potential" of the oscillating tube; by making this sufficiently negative the tube stops generating power as described in Chapter VI, and illustrated in Fig. 117, p. 500.

Fig. 49 shows the diagram of connections for a small oscillating tube set, which utilizes three of the above-named methods of sending. The oscillating circuit involved

were described in Chapter VI, p. 513, and the student is referred there for a discussion of their action.

Referring to the diagram and assuming the switch S thrown upward, i.e., open, it will be noted that the antenna circuit will be completed by the closing of the key K . Therefore, if the key is open, the antenna circuit is open, the tube does not oscillate, and no energy is radiated. When the key is closed, completing the antenna circuit, oscillations will start and be maintained, if the proper conditions have been fulfilled. Thus energy will be radiated as long as the key is held closed and will cease when the key is opened. Therefore with the switch S in the "up" position, transmission is on the "cut-in" method.

If the switch S is thrown to the right so as to make contact with terminal a , then transmission will be by the "compensated" method. This may be seen from the following: with the key open, the antenna circuit is completed to ground through L_x ; the tube will therefore oscillate and the antenna radiate energy at a wave-length determined by the constants of the circuit, including L_x ; the wave-length of the energy radiated while a signal is being sent is therefore less than the wave-length of the energy radiated during a space interval. Transmission is thus in accordance with Fig. 41-II.

Throwing the switch S to the left so as to make contact with terminal b , will permit sending on the "modulated" method. With the key open, the antenna circuit includes the buzzer winding and so the set will not oscillate. When the key is closed, two results are produced: First, the buzzer circuit is completed through the filament battery and the buzzer will vibrate as long as the key is down; second, the vibrating buzzer armature alternately makes and breaks the antenna circuit; therefore, when it completes the circuit, oscillations occur and energy is radiated, while during the break no oscillations are possible. The energy radiated is thus as shown in Fig. 41-III. It should be noted that when the buzzer armature is in the open position, the antenna circuit is not actually opened, but is completed through the filament battery and buzzer winding to ground. Due to the high impedance and resistance of the latter to the flow of high-frequency currents, oscillations are prevented as effectively as though an actual break has occurred in the antenna circuit.

Use of Radiophone Transmitting Set for Undamped-wave Telegraphy.—A novel and effective scheme for transmitting undamped wave signals is shown in Fig. 50.

The operation and action of the radiophone set shown is discussed in detail in a later chapter (see Chapter VIII), and it is there shown that when sound waves strike the transmitter diaphragm, a high-frequency current of constant amplitude flows in the antenna, and constant power is radiated. When the transmitter is spoken into, the amplitude of the antenna current (and radiated power) varies in proportion to the intensity and frequency of the sound waves set up by the speaker.

Similarly, a buzzer, placed in front of the transmitter, would set up sound waves of constant frequency and intensity, and cause the radiated power to vary in accordance with the pitch of the buzzer note. By using

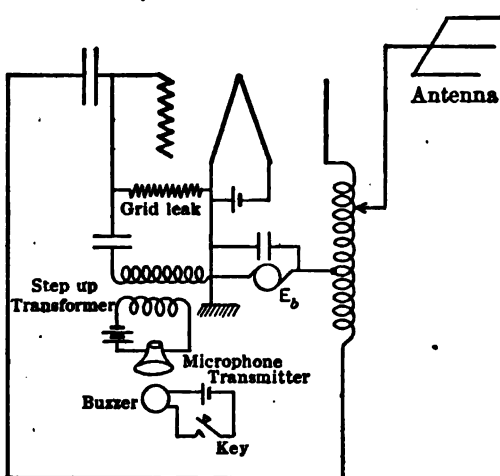

FIG. 50.—A scheme for using a radiophone set to send continuous-wave telegraph signals. Of course, the buzzer and switch may be inserted directly in the circuit, in place of the microphone, if more complete modulation of signals is desired.

a high pitch buzzer of proper construction, a very clear transmission, possessing a high degree of selectivity, may be easily obtained.

The form of the antenna current while the buzzer is in operation (key closed) would be as shown in Fig. 12, p. 657, the amplitude varying periodically at buzzer frequency, above and below the constant amplitude maintained when the key is open. The reception of such signals is similar in every way to that of radiophone messages or tele-

graphic transmission by the "modulated" method, no "beat" reception or special receiving devices being required.

Advantages and Disadvantages of the Cut-in, Compensated, and Modulated Methods of Signal Transmission.—The advantages and disadvantages of the several methods of sending described above may be summarized as follows:

"CUT-IN" METHOD. *Advantage.*—Only one wave-length is radiated after the antenna current has risen to its normal effective value, and energy is radiated only when signal is being sent. Signal is easily received, and permits of a high degree of selectivity.

Disadvantage.—Not suitable for such generators as the Poulsen arc, which do not operate well until the "steady state" has been reached.

"COMPENSATED" METHOD. *Advantage.*—The oscillations are continuous. This method must be employed for the Poulsen arc (neglecting the dummy antenna as an alternative). Transmission is reliable, as the change in wave-length, as the key is operated, is positive and certain.

Disadvantage.—The power efficiency is comparatively low because the set requires full power all the time, whether radiating a

“signal” or not. A more serious disadvantage arises from the fact that each sending set “uses up” two different wave-lengths. This latter feature is especially undesirable when long wave-lengths are employed; the difference in frequency of the signal wave and compensation wave should be about 1000 cycles per second, and thus the number of arcs which can be used in one district, in the long wave-length range may be seriously limited.

“MODULATED” METHOD. *Advantage.*—The primary advantage of the modulated method is that the signals can be received by means of an ordinary crystal or non-oscillating vacuum-tube receiving set. Thus, if the special continuous-wave receiver is out of service for any reason, the ordinary receiver may be used for reading the message. Radiation occurs only while key is closed, thus increasing efficiency.

Disadvantage.—Less energy is radiated since the energy is broken or chopped into groups. A continuous stream of energy, with given maximum potential on the antenna, sends off more power than a series of “trains” and when utilized in a proper receiving set, permits communication over a greater distance than the modulated signal. With the modulated signal the selectivity is poorer than that obtainable by means of the cut-in method under similar conditions; thus the number of neighboring stations, operating in a given wave-length range, without serious interference, is less.

Reception of Continuous-wave Signal. Necessity for Special Receiving Sets.—That some special means must be provided for the reception of continuous wave signals, in addition to the simple rectifying device, i.e., a crystal or vacuum tube, will be evident from the following: if we consider an undamped wave-generator transmitting on the “cut-in” method, and this energy being received by a simple crystal or vacuum-tube receiver, the potential across the receiver circuit will have the form indicated in Fig. 51, curve A.

The rectifying action of the crystal or tube produces an asymmetrical change in current through the phones, the mean current being indicated by the dotted line, Fig. 51B. Since the diaphragm is only actuated to give a click when a sudden variation of the mean current through the phone is produced, the result is a slight click at the beginning and end of each signal. Evidently, the message received would be unintelligible.

If we consider signal transmission by the “compensated” method, the results are similar and may be even worse, depending on the sharpness of tuning at the receiving station. Conditions would be as shown in Fig. 52.

It is evident that if the signal and compensation waves are practically equal in amplitude (as they may be under broad tuning conditions), no clicks at all will be heard in the phones.

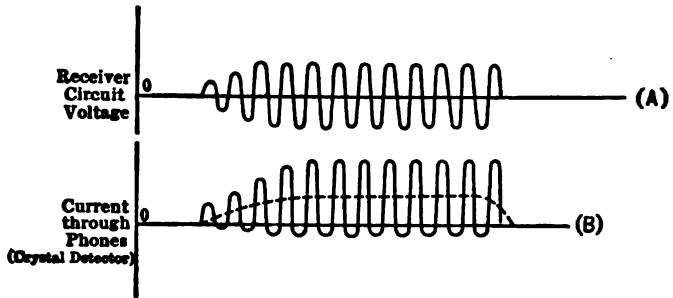

FIG. 51.—Action of crystal detector receiver on continuous-wave signal being sent by the "cut-in" scheme.

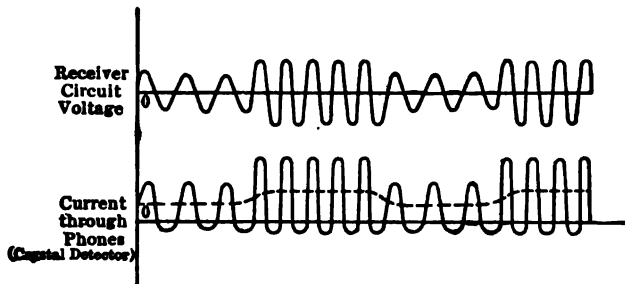

FIG. 52.—Action of crystal detector for compensated continuous-wave signal.

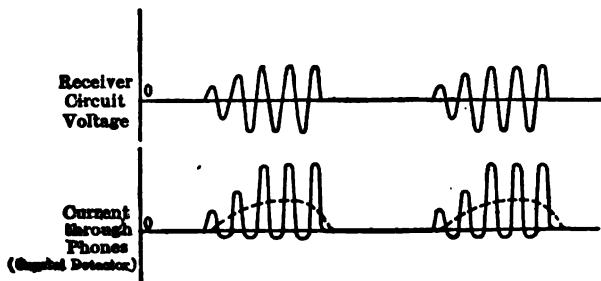

FIG. 53.—Action of crystal detector on a modulated continuous-wave signal.

If the set is sending on the "modulated" method, the signal is received exactly as in the case of a spark signal. The action is indicated in Fig. 53. This shows the mean current through the phones to vary at audio frequency (chopper or buzzer frequency) when the key is held closed, and the signal is thus made audible to the observer.

Action of Continuous-wave Receivers.—The above curves and discussion indicate that in order to receive continuous-wave signals, some device must be used, which, when interacting with the incoming signal, will give an audio frequency component. This component, in turn, after rectification, causes pulses of audio frequency to occur in the phones, the corresponding note being heard by the observer as long as the incoming signal energy continues. With the compensated method of sending the space and signal note there may also be differentiated by their difference in pitch, as described later.

Continuous Wave Receivers.

Tikker.—The connections for this device are indicated in Fig. 54.

C_2 is an ordinary variable tuning condenser while C is fixed and comparatively large in value (about $1 \mu f.$). The tikker T consists of a revolving brass disk upon which a fine steel wire is placed in light contact. Due to slight irregularities in the surface of the disk the contact closes and opens intermittently at an audio frequency determined by the condition and characteristics of the tikker. While the contact is off, the antenna is supplying energy to the closed circuit, L_2-C_2 , and a comparatively large amplitude of current builds up in this circuit. The action is similar to the action of the resonance transformer of a spark transmitter (see p. 307). When the tikker makes contact, the energy accumulated in condenser C_2 discharges over into C , which, due to its large capacity, takes a long time to charge, and the contact has already opened before it can discharge back into C_2-L_2 . Therefore it discharges through the phones, producing a click. A click will be produced in the phones for each opening of the tikker and the note heard will thus depend on the tikker constants, and is therefore controllable by the speed of the tikker disk. It should be noted that no separate rectifier is needed. The tone obtained is not musical, since contact may occur with C_1 charged to varying potential differences due to irregular and varying contact.

Chopper.—Instead of breaking up the energy at the transmitting end as in the "modulated" method, the interrupter element may be connected at the receiver, as shown in Fig. 55.

This differs from the tikker in that a detector element is required while the large condenser across the phones is omitted. Normally, the chopper consists of a rotating toothed wheel making contact with a brush element, or a buzzer may be used. The action is simply to "chop up"

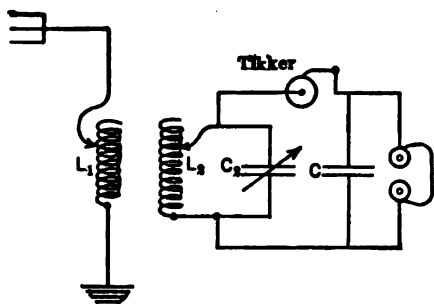

FIG. 54.—Method of receiving continuous-wave signal using a tikker as detector.

the stream of received energy into audio frequency groups of oscillations which are then rectified to produce an audible note in the phone.

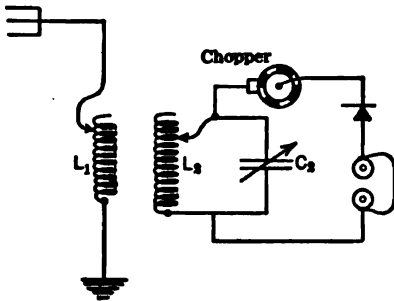

FIG. 55.—Scheme using chopper and rectifier to receive continuous-wave signals.

The Goldschmidt Tone Wheel is essentially an interrupter element, but due to its comparative high speed of rotation (near synchronism), no detector element is required. It consists of a toothed wheel, making contact with a brush, and designed to run at synchronous speed at a reasonable r.p.m. If we assume a wheel with 800 teeth and slots (of equal width), the synchronous speed for a frequency of 50,000, would be

3750 r.p.m., which is within safe limits. If we consider a signal of 50,000 cycles/sec. frequency (6000 meters) being received, and the wheel traveling at synchronous speed, the result may be as shown in Fig. 56, *B* or *C*,

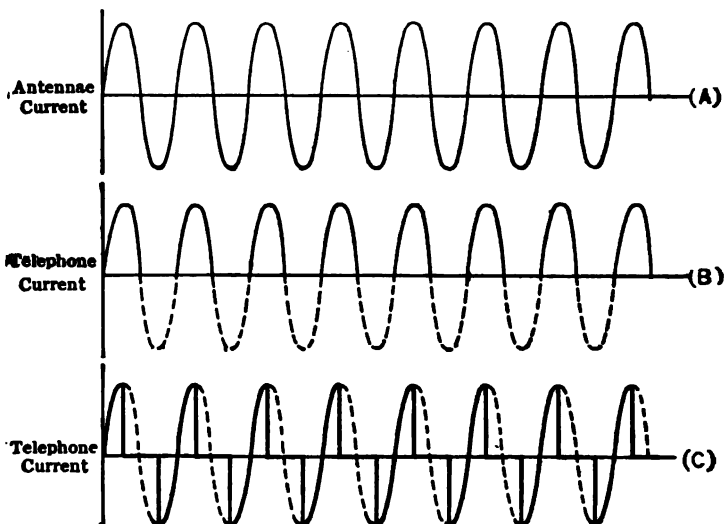

FIG. 56.—Use of tone wheel for receiving continuous-wave signals; at synchronous speed it will give no signal.

depending on the phase of the interruptions referred to the high-frequency current.

The form of the phone current will be different for different points of interruption, but in any case, constant amplitudes will be obtained if the wheel is run at synchronous speed and no signal will be obtained. If the wheel is run above or below synchronous speed, then the successive

cycles are not interrupted at the same point, but the point of interruption will shift as shown in Fig. 57.

The telephone will thus be periodically impulsed by the audio frequency component of the resultant current flowing through the phones as indicated by the dotted curves in Fig. 57. The frequency of this current is the difference between the frequency of the wheel and the incoming signal. Thus, for the machine considered above, and an incoming fre-

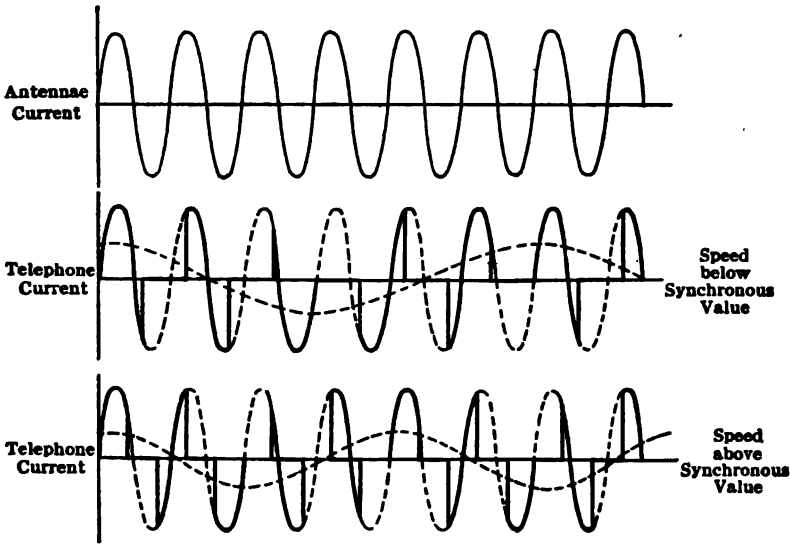

FIG. 57.—The tone wheel run either higher or lower than synchronous speed will act to give a musical note signal, the pitch being fixed by the difference between the actual speed of the tone wheel and synchronous speed.

quency of 50,000, the speed would be as shown below for a desired audio frequency of 1000 cycles per second.

$$f = f_1 - f_2 = 1000 = 50,000 - 49,000 \text{ running below synchronism}$$

$$f = f_2 - f_1 = 1000 = 51,000 - 50,000 \text{ running above synchronism}$$

where f_1 = frequency of incoming energy;

f_2 = frequency of interruptions caused by the tone wheel

also
$$f_2 = \frac{\text{r.p.m.}}{60} \times \text{No. of teeth} = 49,000, \text{ or } 51,000 = \text{r.p.m.} \times 800$$

thus

$$\text{synchronous speed} = 3750 \text{ r.p.m.}$$

and

tone wheel speed for $f_2 = 49,000 = 3680 \text{ r.p.m.} = 70 \text{ r.p.m. below synchronism}$

tone wheel speed for $f_2 = 51,000 = 3820 \text{ r.p.m.} = 70 \text{ r.p.m. above synchronism}$

The note may thus be easily adjusted to give maximum audibility by altering the speed of the tone wheel.

This device operates in some respects similarly to the heterodyne receivers discussed below, although no local frequency is generated. The pitch of the note received does, however, depend on the speed of the tone wheel, which permits its adjustment to give a musical note which can easily be heard through static and minimizes interference to some extent. This is evident when it is considered that the interfering station must radiate practically the same wave-length as the station whose message it is desired to receive if much interference is to occur. A very slight difference in the wave-length causes a relatively large difference in pitch of the resultant note, and the interference is thus easily identified and may be eliminated by properly altering the speed of the tone wheel.

This receiver was specially developed for use in connection with the Goldschmidt system of undamped wave-transmission, and was used to some extent in the stations utilizing this system, notably those at Hanover, Germany, and Tuckerton, N. J., U. S. A.

Rotating Plate Condenser.—Another scheme for the reception of undamped wave signals is shown in Fig. 58.

The movable plates of condenser C_2 are rapidly rotated by a small motor or similar means so as

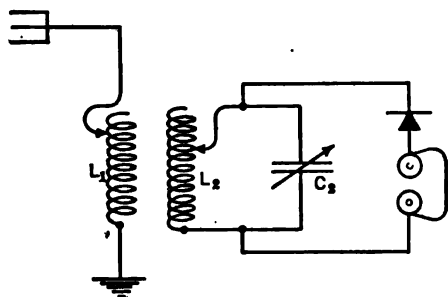

FIG. 58.—By rotating the plates of the tuning condenser, the use of a crystal detector makes a continuous-wave signal audible, the pitch of the note being fixed by the rotational speed of the condenser.

to cause the circuit L_2-C_2 to be in tune for a small interval of time during each revolution. While in tune the current in the detector-phone circuit will be much greater than at other times and a series of impulses, one for each revolution, is thus exerted on the telephone diaphragm. The action is somewhat similar to that of the chopper, but differs in that no circuits are interrupted.

Heterodyne Receiver or "Beat" Receiver.—The receivers

described above have all been applied to the reception of undamped wave signals in the past, but at the present time have been superseded by receivers involving the generation of local high-frequency currents by means of oscillating vacuum tubes. The advantages of this type of receiver over the earlier schemes are:

1. Ease of operation.
2. Simplicity.

3. Greater selectivity and sensitiveness.
4. Lower cost.
5. Small space requirements and portability.

Its operation is based on the idea of combining two currents of different frequencies to produce a resultant current the amplitude of which varies periodically (first used by R. A. Fessenden), the frequency of this amplitude variation being the difference between the two component frequencies.¹ This method is known as the heterodyne or "beat" method, of which two schemes may be used, known as the separate heterodyne and self heterodyne (autodyne), depending on whether the detecting device is distinct from the local high-frequency generator, or whether the two functions are performed by the same piece of equipment, i.e., a vacuum tube. The former is sometimes simply called the "heterodyne" method,

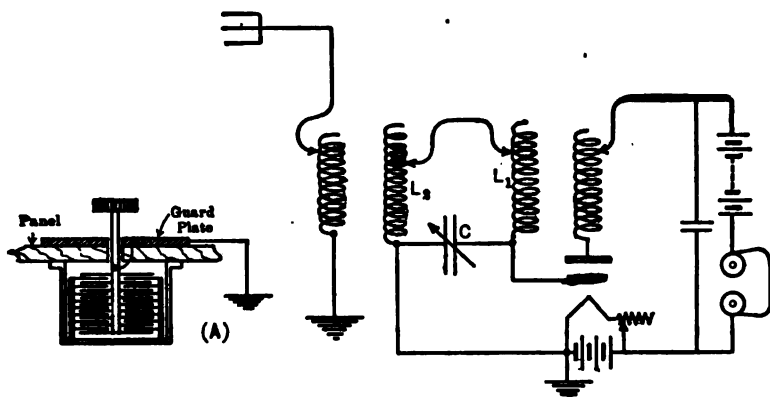

FIG. 59.—The oscillating tube as receiver; it uses the beat note idea and is used to-day universally.

while the latter may be called the "self-heterodyne" or "autodyne" method of reception.

Self-heterodyne Receiver or Autodyne.—The self-heterodyne receiver, utilizing an oscillating vacuum tube as a generator and detector, is undoubtedly the most important of recent developments in the field of radio, and will be described somewhat in detail. A possible connection for the receiving set is indicated in Fig. 59.

If the various oscillation requirements of the tube have been satisfied, the tube will oscillate at a frequency determined by the constants of the local circuit, L_2 , L_1 , C , and a current of this frequency will flow in the local circuit.² This is known as the local high-frequency current, and is indi-

¹ See Chapter VI, p. 483, for mathematical analysis.

² For analysis of conditions required for oscillation see Chapter VI, p. 510.

cated by curve *a*, Fig. 60. Assume its frequency to be 1,000,000 cycles/sec. Now consider that the transmitter is operated on the "cut-in" method and is radiating at a frequency of 999,000 cycles/sec. A portion of this energy strikes the receiving antenna, which is tuned to it, and a maximum current is caused to flow in the antenna. This, in turn, induces an e.m.f. in the coil L_2 and causes a current whose frequency is 999,000 to flow in the local oscillating circuit. This current is called the incoming high-frequency current and is shown in curve *b*. (It should be noted that the antenna and local oscillating circuits are slightly detuned.)

The two high-frequency currents, flowing in the same circuit, combine to give the resultant current indicated in curve *c*, which shows the periodic variation in amplitude produced. These periodic variations in amplitude are called "beats," and the beat frequency is always the difference between the component frequencies. (A "beat cycle" consists of one complete rise and fall in amplitude). For the values assumed above the beat frequency would thus be $1,000,000 - 999,000 = 1000$ cycles/sec. It is to be particularly noted that the frequency of alternation of this resultant current¹ is the mean of the two component frequencies, namely, 999,500 for the values assumed. The resultant current is therefore a radio frequency current.

The drop across condenser *C* will have the same form as the current curve $\left(E_c = \frac{I}{2\pi fC}\right)$ and is identical with the variation in grid voltage E_g .

The effect of this variation in grid voltage upon the plate current depends on the point of the characteristic curve at which the tube is being operated. If it is assumed that operation is on the lower bend, the plate current will vary as shown on curve *d*. This variation may be resolved into two components as shown in curves *e* and *f*, *e* flowing through the bridging condenser, while *f* flows through the phones. The latter component varies at beat frequency, and if this frequency is high enough, a musical note is produced in the phones, which is maintained as long as the key is held closed at the transmitter. Opening the key leaves only the local high-frequency current flowing and no variation of plate current at beat frequency is produced, hence no note is heard in the phones. If the tube stops oscillating and the incoming signal is maintained, the same result is obtained.

If it is assumed that the tube is oscillating symmetrically with respect to the upper and lower bends of its characteristic curve, the mean plate current remains unchanged (giving no current of audible frequency) although a beat frequency variation in amplitude is produced. This means that

¹ On the basis of measuring frequency by the time between successive zero values. At the points of minimum amplitude the phase reverses as explained in Chapter IV, p. 241.

the tube must be operated on a rectifying part of the curve if a signal is to be heard. Of course if a condenser is used in series with the grid, a signal will be heard, no matter what part of the curve the tube is operating on, as pointed out in Chapter VI, p. 451.

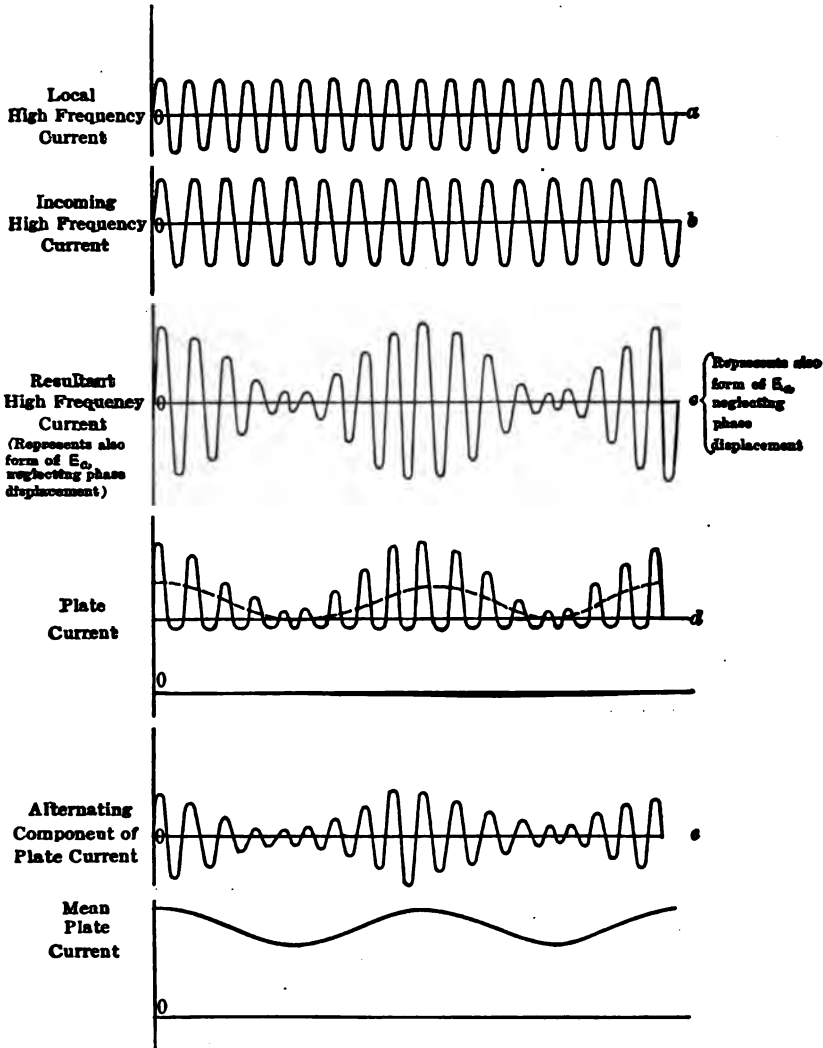

FIG. 60.—Action of the tube as a beat receiver.

The above discussion indicates that the receiving tube must perform simultaneously the functions of oscillation and rectification. Failure of either would result in no signals being received. These functions, which are performed by the one piece of apparatus in the self-heterodyne

receiver described above, may evidently be performed by two different tubes or a tube and high-frequency alternator. Connections for a "separate heterodyne" receiver utilizing two vacuum tubes is indicated in Fig. 61.¹

Control of the Beat Frequency or Pitch of the Signal Note.—It is evident that the local high frequency may readily be controlled by the variable condenser *C*. If the incoming high frequency is 1,000,000, and condenser *C* is of too large a value, the local frequency may be low, for instance 900,000 cycles/sec. The beat frequency is thus 100,000 cycles/sec. which is above the audible limit. As the value of *C* is decreased, the local frequency increases, the beat frequency decreases, and as the audible values are reached, the pitch of the note heard in the phones (i.e., the beat note) will change from a very high pitch to lower and lower values, until, when the two frequencies coincide, the beat frequency is zero and no sound is heard in the phones. (In this case we have the addition of two

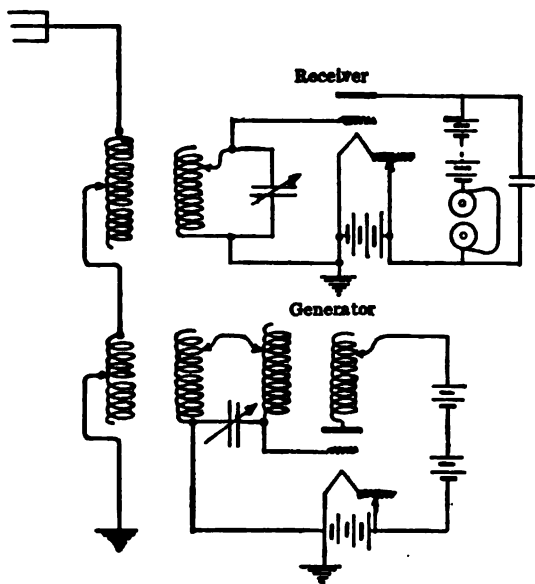

FIG. 61.—Instead of using the detector tube to produce the local oscillations for beat reception, a separate oscillating tube may be coupled to the antenna.

currents of the same frequency, producing a resultant current of constant amplitude. The mean plate current thus has no periodic variation in amplitude; i.e., the beat effect is absent.) As the capacity continues to be decreased, the local frequency increases, and the difference between the local and incoming frequencies again increases; i.e., the pitch of the beat note in the phones again rises until it disappears at the limit of audibility. The above phenomenon is illustrated by Fig. 62. (Curve A.)

In connection with the foregoing discussion it may be noted that in the practical installation or assembly of a heterodyne receiving set, the handle of the variable condenser *C* should be on the ground side, thus grounding the moving plates. If the apparatus is assembled in a contain-

¹ For more detailed study of the action of this type of receiving circuit see Chapter VI, p. 516.

ing case, a metal plate should be placed in front of the condenser and electrically connected to the moving plates. See Fig. 59A. This precaution prevents any change in frequency due to the proximity of the observer's hand or body near the condenser and is extremely important on short wave-length receivers.¹

Effect of Upper Harmonics.—Since the vacuum tube does not generate a pure sine current of fundamental frequency, but also produces upper harmonics, a unique phenomenon is observed when the heterodyne receiver is close to an oscillating tube transmitter, as may be the case in the laboratory.

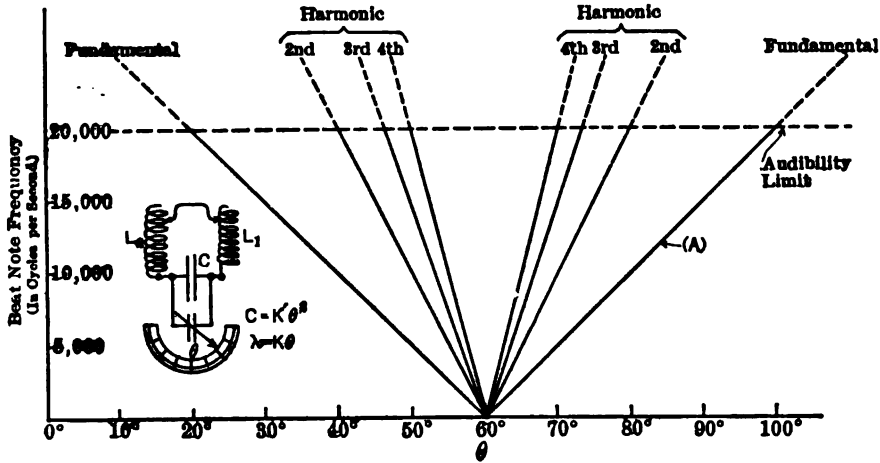

Fig. 62.—A diagram for analyzing the peculiar noises heard when an oscillating tube receiver is close to a continuous-wave transmitter.

Referring to Fig. 62 the combination of the fundamentals will produce the pitch curve designed as A, this note being assumed as becoming audible² when the condenser is set to the 100° graduation on the condenser scale. As the condenser value is decreased from 100°, a value is reached (at 80°) when the combination of the second harmonics produce a just audible beat note, this note as well as the fundamental beat note being heard simultaneously as the condenser value is further decreased. At certain smaller values (73.3° and 70° on the scale) of condenser capacity, the interaction of still higher harmonics (third and fourth) produces additional beat notes. Thus, in the figure, four beat notes will be heard simul-

¹ Of course a much better scheme is to mount all the parts of the receiving circuit inside of a thick copper box, grounded.

² The upper limit of audibility here assumed, is much higher than that of the ordinary person; generally an adult cannot hear a note higher than 14,000–15,000 complete vibrations per second.

taneously in the phones at condenser adjustments between 70° and 60° . At 60° the fundamental beat note and the upper harmonic beat notes all pass through zero frequency simultaneously, and as the condenser value is further decreased, the beat notes increase in pitch and successively become inaudible again as shown. These effects are summarized in the following tabulation:

	Harmonic.	Transmitter.	Receiver.	Beat Note.
C = 65°	Fundamental	1,000,000	997,500	2500
	2d Harmonic	2,000,000	1,995,000	5000
	3d Harmonic	3,000,000	2,992,500	7500
	4th Harmonic	4,000,000	3,990,000	10000
C = 60°	Fundamental	1,000,000	1,000,000	
	2d Harmonic	2,000,000	2,000,000	
	3d Harmonic	3,000,000	3,000,000	
	4th Harmonic	4,000,000	4,000,000	
C = 55°	Fundamental	1,000,000	1,002,500	2500
	2d Harmonic	2,000,000	2,005,000	5000
	3d Harmonic	3,000,000	3,007,500	7500
	4th Harmonic	4,000,000	4,010,000	10000

In actual reception the upper harmonics generated by the receiver are always considerably weaker than the fundamental, and when adjustments are made so that the beat frequency heard is one resulting from the combination of an upper harmonic of the local oscillation and the incoming signal, the signal strength and clearness are very greatly reduced. Thus, in adjusting to receive a 1,000,000-cycle wave, the operator may adjust his receiving circuit to a fundamental frequency of 500,500, tuning to the second harmonic (frequency = 1,001,000) for a 1000-cycle beat note, or he may adjust his set to a fundamental frequency of 300,333, tuning to the third harmonic. Similarly he may tune to the fourth or higher harmonics, if present, reception becoming increasingly inefficient and difficult, due to the smaller and smaller amplitudes of these higher harmonic components. This may be seen from inspection of the curves of Fig. 60; if the local high-frequency amplitude is small, little change in amplitude occurs in the resultant current, which in turn determines the strength of signal.

Upper harmonics may also be produced by the transmitting set as already noted. In this case the receiving set may have its fundamental frequency adjusted to these upper harmonics, and again weakness of signal and inefficiency result. This possibility, however, is relatively small, since:

- 1st. The upper harmonics radiated by the transmitter are weak and ineffective unless the transmitter is close to the receiver as assumed in the detailed description above.
- 2d. The receiving antenna is not tuned to these upper harmonics, still further decreasing their effect on the receiving circuit.



FIG. 63.—Front view of a small continuous-wave transmitter; the high-frequency power is generated by four five-watt tubes.

For illustration, assume the fundamental transmitter frequency as 1,000,000, with a second and third harmonic also being radiated. The receiver in this case may be adjusted to a fundamental frequency of 2,000,000 or 3,000,000, but the beat note in either case will be very much weaker than if the fundamental incoming frequency had been utilized.

The operator, when in doubt, should vary his local frequency over wide limits, and select that adjustment giving maximum audibility.

Possibility of Receiving Undamped-wave Signals with an Ordinary Crystal.—An ordinary damped-wave receiver, using a crystal or simple

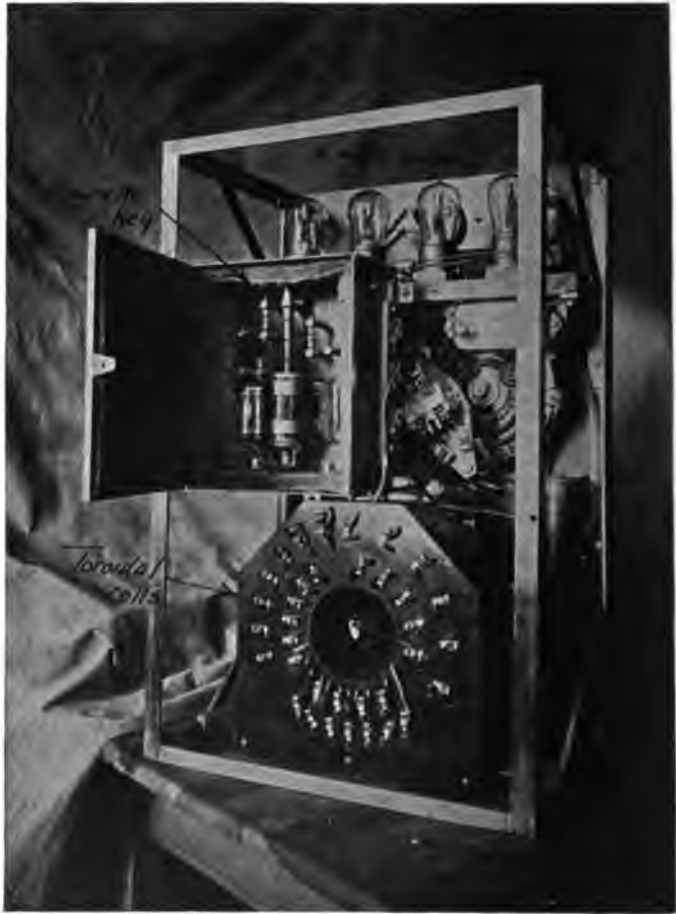

FIG. 64.—Back view of the set shown in Fig. 63; toroidal transmitting coils were used to eliminate local interference. The magnetically operated key is seen in the opened box.

vacuum-tube circuit, may, under certain conditions, receive an undamped-wave signal. The possibility arises when two undamped-wave transmitters are operating simultaneously at practically the same wave-length. Thus, if station *A* sends at 6000 meters (50,000 cycles), while *B* sends at 6060 meters (49,500 cycles), currents of these frequencies will simul-

taneously flow in the receiving antenna, giving a resultant current having a frequency of 500 cycles, which will cause a note of similar frequency to beat be heard in the phones. It is evident that for the signals of either station to be correctly received the second transmitting station must be radiating continuously, acting simply as a high-frequency generator. Thus, if *B* is sending while *A* is tuning his set, with key down, operators with crystal



Fig. 65.—Continuous-wave transmitter using four Type *P* pliotrons; ammeters are supplied for plates and grids, and voltmeter for filament control.

detector sets adjusted for receiving a frequency close to that used by *A* and *B* will be able to read *A*'s signal.

Use of Grid Condenser.—It will be recalled that the tube (in the self-eterodyne circuit) must perform the functions of oscillation and detection. In Chapter VI it was shown that the best point for oscillating is on the straight part of the characteristic curve, while the best point for detection

is on the bend. It has also been noted that the use of a grid condenser improves the detecting action and does not require that the tube be operated on the bend of the curve. In fact, the detection is best when the tube is operated on the straight portion. For these reasons the grid condenser is also used in connection with the heterodyne receiver.¹

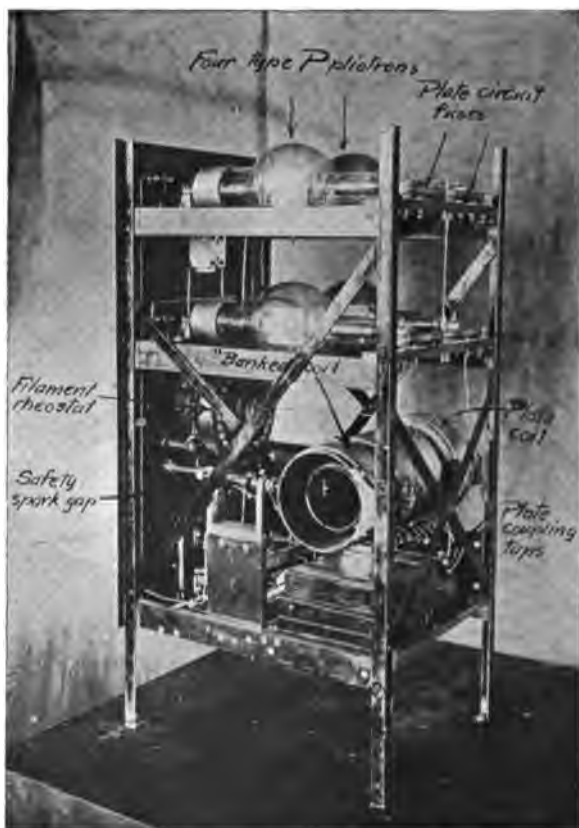

FIG. 66.—Back view of the set shown in Fig. 65; with 1500 volts supplied to the plate circuit this set generates 1 kw. of high-frequency power.

The one disadvantage of using a grid condenser is the possibility of the tube "squealing" or "clicking" and thus obscuring or preventing entirely the reception of signals. This action has been described in a previous chapter² and means employed for its prevention were considered. These means are not uniformly successful in getting rid of the

¹ For analysis see Chapter VI, p. 486.

² See Chapter VI, p. 533.

trouble, however, and it is doubtful if the use of a grid condenser would always be desirable.

Arrangement of Apparatus in Tube Transmitting Sets.—The exact arrangement of apparatus on a vacuum-tube transmitting set depends of course in general upon the use to which the set is to be put. In so far as possible all the apparatus should be assembled on one board, with suitable instruments, rheostats, etc. Figs. 63 and 64 show front and rear views of a set having an output of about 15 watts; it is intended for laboratory use, so that extreme compactness was not necessary. To eliminate as far as possible disturbances to and from other circuits the coils of the set are made toroidal. An electrically operated key is shown in the rear view, this serving to connect the receiving amplifier and telephones whenever the sending key (which operates the relay) is not depressed. For convenience the filaments of the tubes are arranged for power from the 110-volt c.c. laboratory supply. As the antenna load coil is not adjustable (being toroidal) the frequency of the output is regulated by an adjustable condenser, in parallel with the antenna. A Meissner circuit was used in this set, the plate and grid coupling being adjustable so that maximum output might be obtained, no matter what the resistance of the load might be.

In Figs. 65 and 66 are shown two views of a higher power set, this using four Type P pliotrons in parallel, and having an output of one kilowatt at 6000 meters.

CHAPTER VIII

RADIO-TELEPHONY

Field of Use.—The radio-telephone supplements the radio-telegraph in the same manner that the wire telephone supplements the wire telegraph. The advantages of the radio-telephone over the radio-telegraph are that, while the latter requires an experienced operator who is familiar with the code, the former does not, and, therefore, the conversation may be carried on directly between the interested parties. In other words, the same factors operate in favor of the radio-telephone over the radio-telegraph as operate in favor of the wire-telephone over the wire-telegraph.

A comparison between the radio-telephone and the wire-telephone is exactly similar to that between the radio-telegraph and the wire-telegraph. The radio-telephone's accepted field of use is from ship to ship, ship to shore, also from airship to airship and from airship to ground, from one moving train to another and from train to station, and, again, in places over land and over water where it would be either impossible or extremely uneconomical to use wires. An example of this last application would be the speech transmission by radio-phone over the ocean, in which case the length of the cable and the impossibility of using Pupin coils and repeating amplifiers make wire telephony entirely out of the question; the same is true over a desert or other undeveloped region where it would be far more economical to use the radio-telephone than the wire telephone. The above does not, however, mean that these two systems of telephony are antagonistic; on the contrary, it is expected that in the future a subscriber to a wire-telephone system will be able to communicate with passengers on board ships equipped with radio-phone, the transmission of speech being accomplished by wire overland to a central radio station and therefrom by radio to the ship; it is expected that the same will apply to airships. Thus, the two divisions of the telephone art will work hand in hand rather than in any way conflict with each other.

Outline of Principle of Operation.—The two elements necessary for radio-telephony are, of course, the transmitter and the receiver. We will consider the transmitter and the receiver separately and in their simplest forms.

The Transmitter.—Consider Fig. 1, in which the high-frequency alternator, such as an Alexanderson, or Fessenden, alternator, is connected in series with the loading inductance L , the antenna, and the microphone transmitter T . The microphone transmitter may be one of the ordinary carbon granule type, the construction of which is fully explained on page 655; without going into details, it will suffice to state here that such a microphone consists simply of an elastic diaphragm bearing against a mass of carbon granules enclosed in a suitable chamber; the carbon granules form part of an electrical circuit (in the case of Fig. 1 the circuit of the alternator). When the microphone is not being spoken into the diaphragm remains stationary and exerts a constant pressure upon the carbon granules, the resistance of which remains, therefore, constant. On the other hand, when the diaphragm is set vibrating, as is done by speaking into the microphone or through a noise or sound reaching it, the pressure exerted by the diaphragm against the carbon granules changes, and this change of pressure causes the resistance of the carbon granules to increase or decrease in accordance with the displacement of the diaphragm from its position of rest.

In the case of Fig. 1, when the microphone is not being spoken into, the alternator produces a high-frequency current of *constant amplitude*, i. e., an undamped current; the amplitude of this current is adjusted to the maximum by adjusting the inductance L so as to make the natural frequency of the circuit equal to the frequency of the alternator. The current flowing through the antenna under these conditions may be represented by Fig. 2, which simply shows an alternating current of constant amplitude, I_0 .

Now, assume, for the sake of simplicity, that a vibrating tuning fork is placed in front of the microphone. The harmonic vibrations of the tuning fork will cause harmonic vibrations of the microphone diaphragm, and these will produce variations in the resistance of the microphone. Since no other part of the circuit of Fig. 1 is undergoing any change, it is plain that a variation of the microphone resistance will produce a corresponding variation in the *amplitude* of the high-frequency antenna current. Thus, when the diaphragm is displaced inwardly the resistance of the microphone and, therefore, of the entire alternator circuit, decreases,

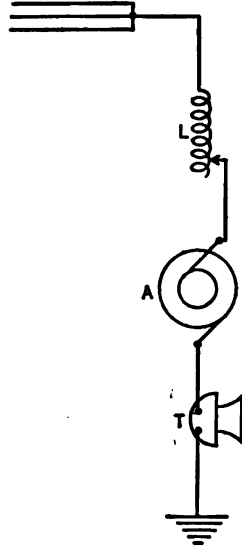

FIG. 1. — The simplest scheme for radio-telephony utilizes a source of high frequency A , and a microphone, T in series with the antenna.

and the amplitude of the current supplied by the alternator must necessarily increase; the reverse takes place when the diaphragm is displaced outwardly.

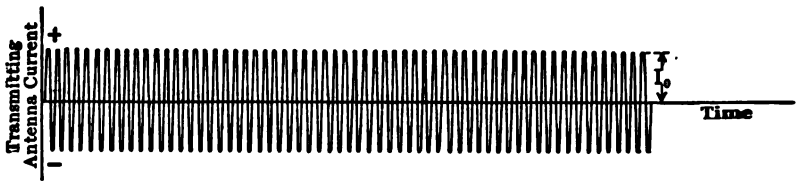

FIG. 2.—When no sound impinges on the microphone the amplitude of the high-frequency current supplied to the antenna is constant.

The antenna current under these conditions would be as shown in Fig. 3, where the curve of the displacement of the microphone diaphragm is also given.

It will be noted that the frequency of the antenna current (as determined by time between successive zero values) must remain the same

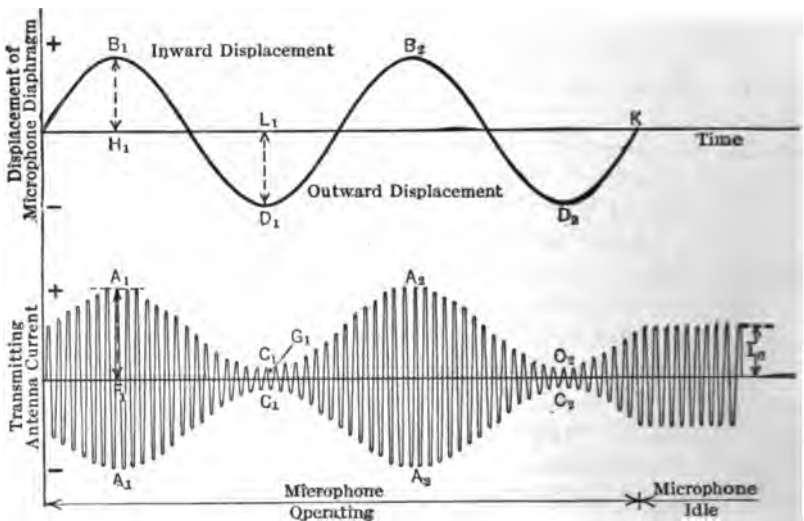

FIG. 3.—If a sound wave actuates the microphone, its inward and outward displacement varying the resistance in the antenna circuit, results in a high-frequency current in the antenna of variable amplitude, called a *modulated high-frequency current*.

whether the microphone diaphragm is operating or not, since it is solely determined by the frequency of the alternator; but the amplitude of this high-frequency current is made to vary in accordance with the tuning-fork vibrations, in so far as this amplitude changes from the maximum of A_1F_1 , corresponding to the maximum inward diaphragm displacement of B_1H_1 , to the minimum of C_1G_1 , corresponding to the maximum out-

ward diaphragm displacement of D_1L_1 . The time between the maximum current amplitudes at A_1 and A_2 or between the minimum amplitudes at C_1 and C_2 is the same as that between the maximum positive diaphragm displacements at B_1 and B_2 or between the maximum negative diaphragm displacements at D_1 and D_2 . Or, in other words, the frequency, with which the antenna current amplitude changes from maximum to minimum and back to maximum, is the same as the frequency of the microphone diaphragm and of the tuning-fork vibrations. When the displacement of the microphone diaphragm is zero, as after the point K , the antenna current becomes the same as in Fig. 2, i.e., of unvarying amplitude.

The antenna current represented by Fig. 3 is said to be "*modulated.*" The high frequency is known in this case as the "*carrier frequency,*" and the frequency of the microphone diaphragm, which is impressed upon the antenna current, is known as the "*modulating frequency.*"

It now remains to show how the modulated antenna current represented by Fig. 3, when received by the receiving antenna, may be made to so affect the diaphragm of a telephone receiver as to reproduce the note emitted by the tuning fork.

The Receiver. — The receiver is exactly the same as used for spark telegraphy, and is reproduced below (Fig. 4) for the sake of convenience.

A crystal detector has been shown as the rectifying element, but a vacuum tube, or any other rectifying device, may be used instead.

The manipulations necessary for the operation of this receiver are the same as for any spark receiver; the antenna circuit and the closed circuit must be tuned to the incoming high frequency, and the coupling between the antenna circuit and the closed circuit should ordinarily be made loose.

It is plain that the e.m.f. impressed upon the receiving antenna, due to the electromagnetic waves emanating from the transmitter, will be an exact reproduction of the current in the transmitting antenna; let it

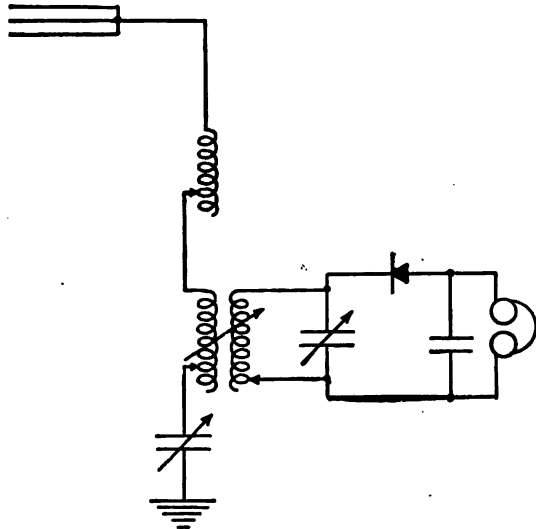

FIG. 4.—For receiving a radio-telephone signal an ordinary receiving set using crystal detector is sufficient.

be represented by the curve below, Fig. 5, wherein the part between *S* and *K* corresponds to a period of action of the distant microphone diaphragm and the rest of the curve corresponds to a position of rest of

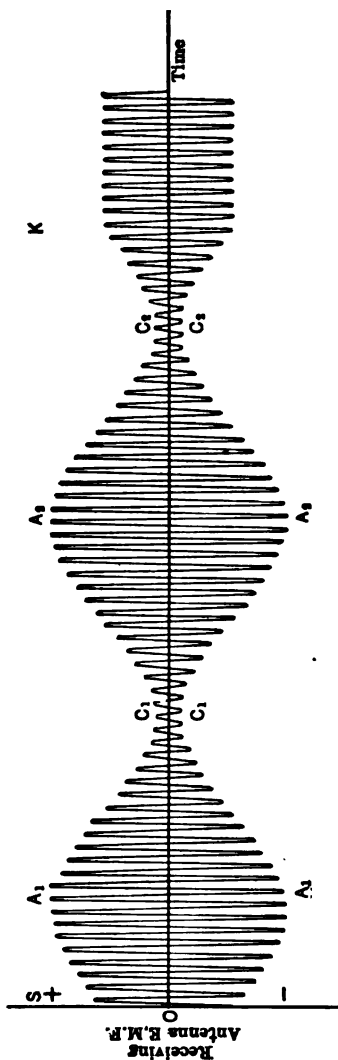

Fig. 5.—The current flowing in the receiving antenna is a modulated high-frequency current, similar in form to the current in the transmitting antenna (providing certain conditions, outlined later, are fulfilled).

the microphone diaphragm. Assume, for the sake of simplicity, that the rectifier used in the receiving circuit has the characteristic represented by Fig. 6; i.e., a characteristic such that a negative e.m.f. impressed upon the circuit of the rectifier produces no current whatsoever and a positive e.m.f. produces a current which varies *directly* with the e.m.f.¹

It is then plain that the e.m.f. impressed upon the receiving antenna and transferred to the rectifier circuit by suitable coupling coils will produce a current in the rectifier circuit of the form shown in Fig. 7. The current of Fig. 7, though unidirectional, is yet one which changes at high frequency, and as such it cannot flow through the high-impedance winding of the telephone receiver; therefore, the current in the receiver will be the average current shown by the dotted curve entered in Fig. 7.

It will be noted that the current in the telephone receiver between *F* and *H*, Fig. 7, which corresponds to a period of activity of the microphone at the distant transmitting station, is one which changes periodically, between a maximum and a minimum, at the "modulating frequency"; on the other hand the current between *H* and *M* correspond-

¹ Rectifiers used in radio work (such as crystal detectors and tubes with or without grid condenser) have a characteristic such that the current varies with the *square* of the e.m.f.; the action of these rectifiers in connection with spark telegraph reception is fully discussed on pp. 343-349. The assumption of a rectifier with linear characteristic, as in Fig. 6, does not involve any change in the fundamental principle of radio-phone reception, and is here made purely for the sake of presenting this matter in the simplest possible manner.

ing to a period during which the microphone transmitter is idle, is constant. The result is that during this latter period the receiver diaphragm will suffer a constant displacement represented by D_0 in Fig. 8; while during the period of activity of the transmitting microphone the displacement of the receiver diaphragm will change somewhat as shown by $B_1-D_1-B_2-D_2$ on Fig. 8, or, in other words, the receiver diaphragm will be caused to vibrate at the modulating frequency, i.e., the frequency of the tuning fork at the transmitting station. Thus, the vibrations of the tuning fork and the sound produced thereby will be duplicated by the vibrations of the receiver diaphragm at the receiving station. It will, of course, be understood that the amplitude of the vibrations of the receiver diaphragm, and hence the volume of sound emitted thereby, will depend upon the strength of the electromagnetic field on reaching the receiving antenna and upon the receiver and detector sensitiveness, etc.

It now remains to show that such a radio-phone system as was discussed above will transmit speech. That is, it is necessary to show that, if we speak into the transmitting microphone and thereby cause its diaphragm to vibrate in accordance with the complex air vibrations produced by speaking, the diaphragm of the telephone receiver at the distant receiving station will vibrate in such a manner as to reproduce speech.

To begin with, the very complex vibrations of the microphone diaphragm, due to speech, may be resolved into an infinite number of *harmonic* components of different frequencies, different amplitudes, and bearing certain phase relations to one another. Experimental investigation has shown, however, that, while the number of these components is theoretically infinite, yet, practically, only the components having frequencies between about 300 and 2000 cycles per second need be considered, since the amplitude of the others is so small as to be negligible.

It has been proved¹ that, as long as the amplitudes of the harmonic

¹ See Bureau of Standards Scientific Paper No. 127, by Lloyd and Agnew.

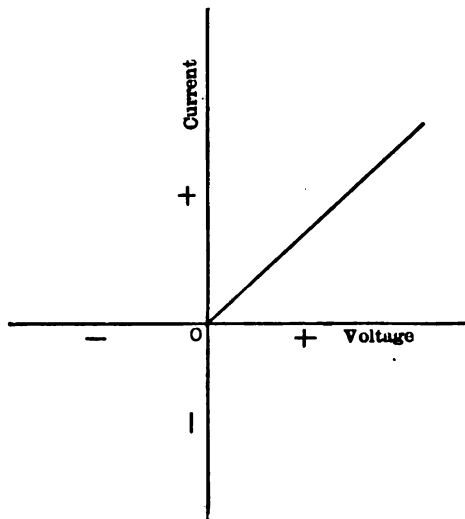

FIG. 6.—To make the discussion of the received signal simple a rectifier with this simple rectification characteristic is assumed.

components of the microphone diaphragm vibrations are reproduced in the vibrations of the receiver diaphragm in the *same ratios* as they have for the transmitter diaphragm, *without any reference whatever to phase relations*, then the speech which caused the vibrations of the microphone

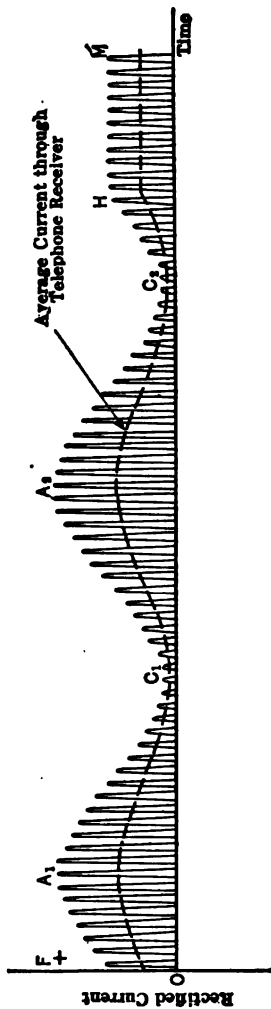

FIG. 7.—The form of current flowing through the crystal and "by-pass" condenser around the phones: the current through the phones is the average value of this unidirectional high-frequency current, shown by the dotted line.

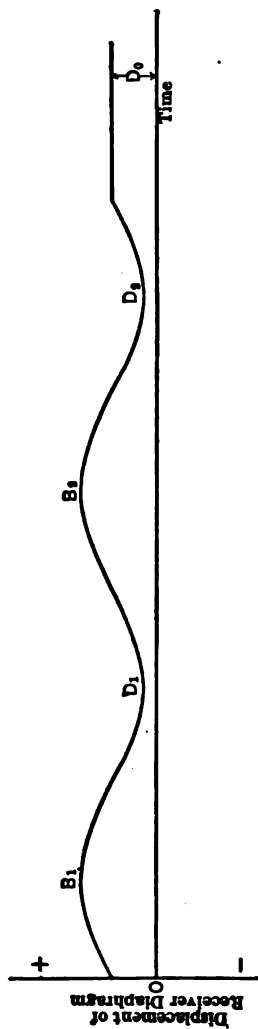

FIG. 8.—Displacement of receiver diaphragm produced by dotted current of Fig. 7; it is assumed that the direction of current through the telephone receiver is such as to weaken the field of the permanent magnet, thus letting the diaphragm move farther out as the current increases.

diaphragm will be faithfully reproduced, *without any distortion*, by the receiver diaphragm. In other words, without paying any attention to phase relations, it is sufficient for transmitting speech that if, as is generally the case, the simple components of the vibrations of the microphone diaphragm are reproduced by the receiver diaphragm with *changed ampli-*

tudes, the percentage change be alike for the amplitudes of all the component frequencies. This principle is of very great practical importance not only in radio-telephony, but in wire-telephony as well.

We have already shown how harmonic vibrations of the microphone diaphragm having a single frequency, such as those caused by a tuning fork, may be reproduced in the receiver diaphragm. It is plain that the amplitude of the displacement of the receiver diaphragm depends upon the intensity of the electromagnetic field on reaching the receiving antenna and upon the constants of the receiving circuit, including the sensitiveness of the rectifier and of the telephone receiver, as well as the amount of coupling between the open and closed circuits, the damping thereof, and also whether the rectified current is amplified by a suitable amplifier or not. Of course the intensity of the electromagnetic field at the receiving antenna is a function of the distance between the transmitting and receiving antennas, the wave-length corresponding to the carrier frequency, the height of the two antennas and the absorption of energy due to the intervening medium, which is in turn a function of the wave-length; hence, no matter what the value of the modulating frequency or the frequency of the transmitter diaphragm, the per cent change in amplitude as related to the displacement of the receiver diaphragm must be the same for all values of modulating frequency, because the percentage of radiated energy which reaches the receiving antenna is dependent upon the *carrier frequency* and *not upon the modulating frequency*. Again, as regards the effect of the constants of the receiving circuit upon the amplitude of the receiver diaphragm displacement the receiving circuit may be so chosen and adjusted that it will affect all modulating frequencies within the speech range to the same extent.

It follows from the above that, if the transmitting diaphragm be spoken into, the displacement of the diaphragm corresponding to each of the possible harmonic components of its vibrations will be reproduced in the receiver diaphragm with practically the *same percentage change in amplitude*, and hence speech will be correctly reproduced.

The carrier frequency should be much higher than the highest important speech frequency, which is in the neighborhood of 5000 cycles per second; therefore, the carrier frequency should be at least above, say, 15,000 cycles per sec. and, as a matter of fact, in actual practice it is seldom lower than 100,000 cycles per sec., and a frequency as high as 6,000,000 cycles per sec. has been used.

It might be thought that this carrier frequency may be dispensed with and the vibrations of the telephone diaphragm may be caused to produce antenna currents of audio frequency, by means of a circuit arrangement somewhat as shown in Fig. 9, where the microphone *M* would, on being spoken into, produce audio frequency currents in the antenna,

through the means of the transformer *T*. This system would fail, because it would require a prohibitively large antenna in order that the audio frequency currents might cause sufficient energy to be radiated for successful transmission over a reasonable distance; hence the use of the "high-frequency carrier."¹

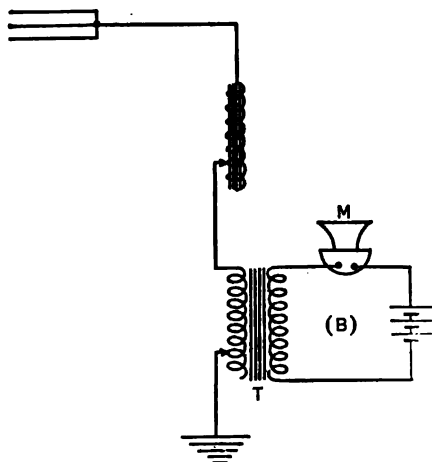

FIG. 9.—Such a scheme as this, dispensing with the carrier frequency, cannot be used because practically no power can be radiated from an antenna with currents of voice frequency.

It is hardly necessary to emphasize the fact that the generator of the high-frequency carrier must be such as to cause by itself no change in the amplitude of the high-frequency carrier; otherwise this would be heard in the receiver, together with the speech, and would interfere with the latter. In other words, the high-frequency generator must not interfere with the modulation of the high-frequency current as brought about by the microphone transmitter.

Sources of Power.—The sources of power which may be used are those which will produce undamped high-frequency currents. (See p. 580, Chapter VII.) Of these various sources the following have been most generally used for radio-telephony:

The Poulsen Arc.

The Alexanderson or Fessenden Alternator.

The Oscillating Vacuum Tube.

All of the above have been fully described in Chapters VI and VII, and we shall, in this chapter, study the manner only in which each of them may be connected for successful radio transmission of speech.

Before going any further we will first briefly describe various types of telephone transmitters and will later discuss the manner of using them in radio-telephone circuits.

Transmitters.—The transmitters used for radio-telephone are broadly divided into two general classes on the basis of their current carrying capacity, i.e.:

(a) Low-current or low-capacity transmitters.

(b) High-current or high-capacity transmitters.

The low-current transmitter for radio-telephony does not differ from

¹ It is shown in Chapter IX, that the power radiated from a simple antenna increases with the square of the frequency.

the transmitter used in wire telephony, and its most common type will here be described. This type is known as the solid-back carbon transmitter. The simple schematic diagram of Fig. 10 illustrates its construction when stripped of details. It consists of an elastic diaphragm *A* mounted upon the rubber ring *FF*, which is in turn held against *E*, the diaphragm being mechanically connected to the carbon block *B'*. *B'* is placed opposite another carbon block *B* in a chamber filled with small carbon granules *C*; this chamber is closed by means of the mica washer *G* and the insulating nut *H*. The two carbon blocks *B* and *B'* form the two electrical terminals of the transmitter; the wall of the chamber containing the granules is covered with a strip of paper designated by *D*; if a source of e.m.f. be connected to *B* and *B'* it will send a current from *B* through the carbon granules and to *B'*, or vice versa. On speaking into the transmitter the diaphragm is caused to vibrate, and these vibrations are mechanically transferred to the block *B'* so that the latter's pressure upon the carbon granules is made to vary; this varies the resistance between *B* and *B'*, and hence it varies also the current in the circuit wherein the transmitter is connected.

Such an arrangement is very sensitive to changes in pressure on the diaphragm and is known as a microphone transmitter. The current carried by such a transmitter is very small because of the fact that a limit is soon reached beyond which "arcs" are developed between granules, the contact points of which become red hot, and the transmitter becomes useless. The current-carrying capacity of an ordinary transmitter is about 0.1 ampere, and its average resistance when not spoken into is 50 to 100 ohms, so that the power capacity is a maximum of $0.1^2 \times 100$ or 1 watt. Some special microphone transmitters "low resistance," may be obtained which have a resistance of 10 to 20 ohms and a current-carrying capacity of 0.5 ampere, or a maximum power capacity equal to $0.5^2 \times 20$ or 5 watts.

The high-current or high-capacity transmitter has received a good deal of attention at the hands of radio engineers and inventors, and many types have been developed, the most important of which will be very briefly described. The reader is referred for more information upon

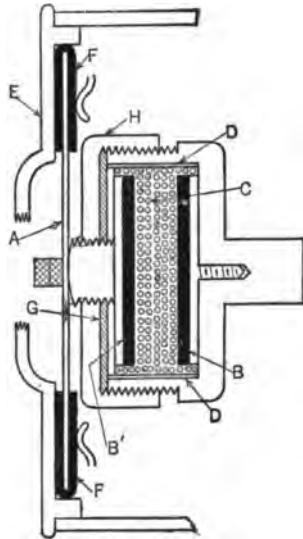

FIG. 10.—Internal construction of the ordinary microphone; the carbon granules between plates *B* and *B'* are the seat of the variable resistance.

this subject to a more detailed treatise on radio telephony.¹ These transmitters might be grouped into two general classes:

- (1) Those using carbon granules.
- (2) Those using liquid jets.

In the first class belong several types of transmitters wherein the carbon granules of the microphone transmitter previously described are kept from overheating by an air fan, or by the circulation of water or by using a slowly flowing stream of carbon granules. Again, in one type, a number of microphones are connected in series—multiple, thus producing a transmitter of much larger current and power capacity than the individual microphones; such transmitters may be constructed to carry from 3 or 5 amperes without overheating.

Typical of the second class is Chambers' liquid microphone, illustrated in Fig. 11. This consists briefly of a metallic diaphragm *A*, against which there is made to flow a stream of electrolyte *B* coming from the pipe *C*. The terminals of the transmitter are attached to *A* and *C*. The vibrations of the diaphragm vary the area of contact between itself and the jet and thus vary the resistance between *C* and *A*. The capacity of such a transmitter is quite high, in so far as the only limitation is the eventual boiling

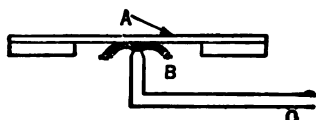

FIG. 11.—A simple type of liquid jet microphone, designed to give low resistance and high power-absorbing capacity.

of the liquid; it has been constructed to take care of 400 watts.

Thus, low-capacity transmitters may be constructed of 1 to 5 watt capacity and 100 to 10 ohms resistance respectively, while high-capacity transmitters have been constructed of 50- to 500-watt capacity and of about 8 to 4 ohms resistance, respectively.

Conditions for Best Modulation.—We will again note that the speech transmission is brought about simply by changing the amplitude of the transmitting antenna current (modulation of antenna current); in other words, if the amplitude of the antenna current should be changed but little by the operation of the telephone transmitter, speech would be transmitted but poorly and to a short distance, while the opposite is true. In other words, the range and quality of transmission does not quite depend upon the amount of current in the transmitting antenna, but upon the *change in this current* or the extent of the modulation. Hence, a radio-phone system should be so designed as to enable the telephone transmitter, when spoken into, to produce the *maximum possible change* in the antenna current. This corresponds to a condition where the antenna current amplitude is caused to reach a minimum of zero, and a maximum which is dependent upon the characteristic of the rectifier in the receiving

¹ See "Radio-Telephony," by A. N. Goldsmith.

circuit. It is therefore necessary to investigate at this point the effect of the rectifier characteristic upon the best conditions for modulation.

Analysis of Modulation.—Assume, as before, the simple transmitting circuit represented by Fig. 1 and the simple receiving circuit represented by Fig. 4; and let us again suppose that a harmonically varying sound pressure is impressed upon the microphone diaphragm by means of, say, a tuning fork placed in front of it. We then desire that the telephone receiver in the receiving circuit shall give off a pure sine wave tone of the frequency of the tuning fork.

We will first investigate the case where the amplitude of the transmitting antenna current is made to change by the action of the microphone from a maximum of *twice that corresponding to the microphone idle to a minimum of zero*, this being what is known as a “completely modulated current.” Fig. 12 shows the curve of the e.m.f. produced in the

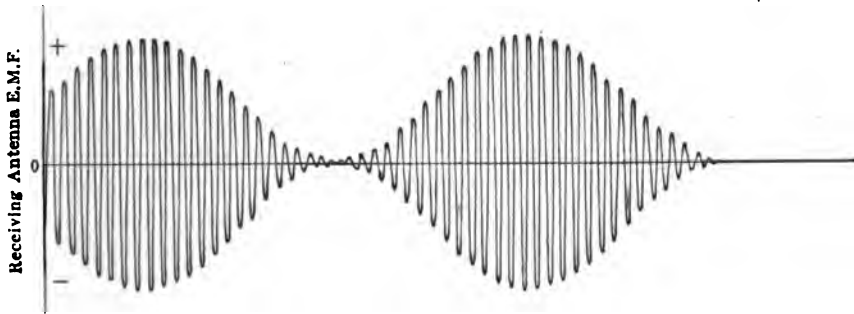

FIG. 12.—A completely modulated antenna current, having a sine-wave envelope.

receiving antenna circuit by the flow of the completely modulated current in the transmitting antenna; the e.m.f. across the rectifier in the receiving circuit of Fig. 4 will be of the same form as Fig. 12, though, of course, reduced in amplitude.

If we assume, as we did before, a rectifier giving a rectified current proportional to the first power of the impressed voltage than the harmonically modulated e.m.f. of Fig. 12 would produce a rectified current the amplitude of which would vary harmonically, as shown by the points marked *A* in Fig. 13, and the result would be that the average current in the telephone receiver would also vary harmonically and cause this to give off a pure harmonic note of the same pitch as that of the tuning fork.

But, as already pointed out in the footnote on p. 650, practically all rectifiers give a rectified current proportional to the square of the impressed voltage; hence the harmonically modulated e.m.f. of Fig. 12 would produce the rectified current represented by curve *B* in Fig. 13, and the curve

of the average current in the telephone receiver would be as represented by the dotted curve *C* of Fig. 13, and would, evidently, not vary harmonically. So that, in this case, the receiving circuit telephone would give

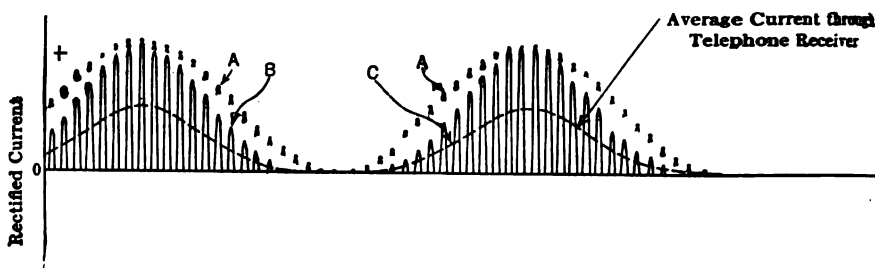

FIG. 13.—The current of Fig. 12, in combination with such a rectifier as that assumed in Fig. 6, would give a rectified current as shown by the points *A*; its average value would be a sine-wave current. If an ordinary rectifier is used the rectified current is as shown by the solid line curves, the average value of which is shown by the dotted curve which is not a simple harmonic current but is more complex in form.

off a note, which, though of the same pitch as that impinging upon the transmitting microphone, would be of a more *complex quality*.

To remedy the objectionable condition brought about by the combination of a harmonically modulated transmitting antenna current and a rectifier giving a current proportional to the square of the impressed

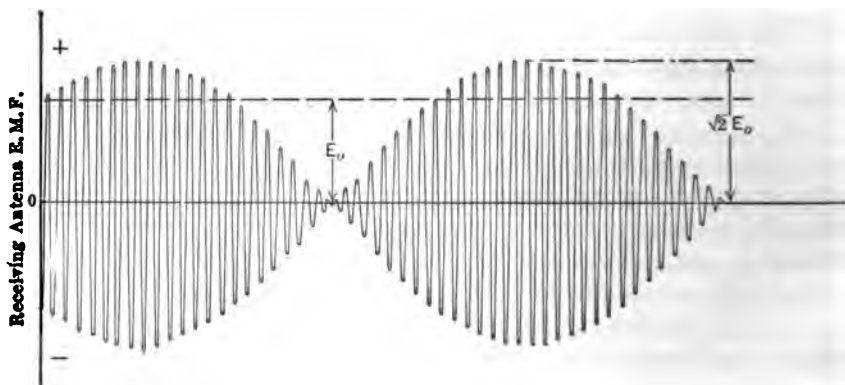

FIG. 14.—A type of modulated current in which the *square of the amplitude* varies as a sine wave.

voltage it is necessary that the transmitting antenna current be differently modulated. Thus, assume that the transmitting antenna current is modulated in such a manner that the difference between the square of its amplitude when modulated and that when not modulated varies with the sine of a uniformly varying angle, so that, if I_0 = amplitude

of antenna current with microphone idle, the maximum amplitude will be $\sqrt{2} I_0$ and the minimum zero. Then, the curve of the e.m.f. acting upon the receiving antenna will be as represented by Fig. 14, the rectified current will be as represented by curve A, Fig. 15, and will have amplitudes which will vary harmonically, and, therefore, the average current through the telephone receiver, represented by curve B, Fig. 15, will vary harmonically. The result will be the reproduction in the telephone receiver of the tuning fork note without any change in the quality of the sound.

From this analysis it follows that, if the sound at the receiver is to

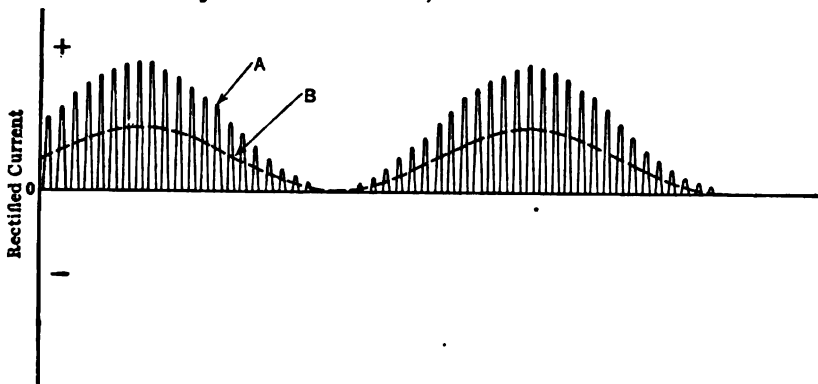

FIG. 15.—Such a current (as that shown in Fig. 14) in the transmitting antenna, with an ordinary type of detector will give in the receiving circuit a rectified current as shown by curves A, the average value of which is curve B, a sine-wave current.

be similar in quality to that acting at the transmitter, either of the two following conditions must be satisfied:

(a) If the receiver circuit *rectifies proportionally to the first power of the voltage impressed upon it*, then the difference between the amplitude of the antenna current with the microphone in operation and that with the microphone idle should vary *in direct proportion* to the pressure of the sound waves on the microphone, or, in symbols

$$I - I_0 = kp \dots \dots \dots (1)$$

- where
- I = amplitude of the antenna current with the transmitter in operation;
 - I_0 = amplitude of the antenna current with the transmitter idle;
 - k = a constant of proportionality;
 - p = the pressure of the sound waves upon the microphone.

(b) If the receiver circuit *rectifies proportionally to the square of the voltage impressed upon it* then the difference between the *square* of the ampli-

tude of the antenna current with the microphone in operation and that with the microphone idle should vary in direct proportion to the pressure of the sound waves on the microphone, or, in symbols:

$$I^2 - I_0^2 = k'p, \dots \dots \dots (2)$$

where I , I_0 , p have the same significance as in Eq. (1) and k' = another constant of proportionality.

Of course, in practice, neither of the two conditions set forth above is fully and entirely satisfied throughout the entire range of pressures impressed upon the microphone diaphragm, and the speech transmission is, therefore, never ideal.

Percentage of Modulation.—The percentage of modulation is expressed by means of the following equation:

$$M = \frac{D_1}{I_0} \times 100, \dots \dots \dots (3)$$

where

- I_0 = amplitude of antenna current with microphone idle;
- D_1 = difference between I_0 and minimum antenna current amplitude;
- M = percentage of modulation.

In the ideal case of a "completely modulated" antenna current $D_1 = I_0$ and $M = 100$ per cent.

Of course, in designing a radio-phone transmitter, the aim is to make the percentage of modulation as large as possible without, at the same time, interfering with the quality of the transmission.

In view of this the idle resistance of the telephone transmitter and the change in the resistance must be carefully chosen with respect to the resistance of the rest of the system. Thus, considering the simple circuit represented by Fig. 1, p. 647, it is plain that if the idle resistance of the telephone transmitter were much lower than that of the balance of the circuit, then any change in the former could not appreciably affect the total resistance and, hence, could not effectively modulate; on the other hand, if the reverse were the case the antenna power radiation would be very small, since the largest percentage of the alternator power output would be absorbed by the transmitter. Thus, there must be a best telephone transmitter resistance and this was shown by Seibt to be equal to that of the rest of the antenna circuit.

In many of the systems of radio-telephony the telephone transmitter is not placed directly in the antenna circuit, but, in practically every case, it is so connected that, by speaking into it, an effect is produced which is equivalent to changing the resistance of the antenna circuit: the telephone transmitter resistance may, in these cases, be transferred

in the form of an equivalent resistance, to the antenna circuit. Hence in practically every case, whether the telephone transmitter is directly in the antenna circuit or not, it should be observed that the optimum idle resistance of the telephone transmitter is such that, when transferred to the antenna circuit, it should be equal to the rest of the antenna-circuit resistance.

As regards the variation in the telephone transmitter resistance it will be noted that, considering the simple system of Fig. 1, and assuming the idle resistance equal to the balance of the antenna circuit, then in order to obtain 100 per cent modulation with a harmonic sound wave and with a receiver rectifying proportionally to the square of the impressed voltage the resistance of the telephone transmitter should change from 41 per cent of its idle resistance to infinity. For, when it is 41 per cent of the idle resistance the antenna current amplitude would be $\sqrt{2} I_0$, and when it is infinity the amplitude of the antenna current would be zero. Of course, it will be easily realized that such extreme variation of resistance is almost impossible of practical accomplishment by means of a microphone; hence 100 per cent modulation by this scheme is impossible.

In practice 50 to 60 per cent modulation is striven for; higher values may be obtained, but are not desirable with the circuit arranged as in Fig. 1, because with such wide variations of microphone resistance the current variations do not truly represent the voice, and the received signal under these conditions is indistinct and blurred.

Various Schemes for Modulation.—These depend very much upon the source used for producing undamped high-frequency currents, although they vary even for the same type of source. The most important ones will be considered in connection with the high-frequency alternator and the Poulsen arc, and a special paragraph will be devoted to the case of tube oscillators.

Referring to Fig. 16, in which various schemes are shown (*a*) is the same as Fig. 1 of p. 647, and has already been discussed. (*b*) shows the telephone transmitter connected in series with the exciting field of the alternator; as the resistance of the telephone transmitter is changed the alternator e.m.f. is changed and so is the amplitude of the antenna current. (*c*) is similar to (*a*) except that the high-frequency current is supplied to the antenna by a Poulsen arc and not by an alternator. (*d*) has the telephone transmitter in the oscillating circuit of the Poulsen arc, thus changing the amplitude of the current in this circuit and hence in the antenna circuit. Many other ways of connecting the telephone transmitter, especially for the Poulsen arc, have been tried and found more or less successful.

As regards the four types illustrated above it is plain that in every one except (*b*) the transmitter should be of large capacity—low resistance,

since it carries either the antenna current or the current in the oscillating circuit of the Poulsen arc. In case (b) the transmitter need only be of low capacity—high resistance, since it only carries the field current of the alternator. However, in this case a certain change in the resistance of the transmitter may not produce a proportional change in the amplitude of the antenna current (a requirement for good modulation) unless the magnetic field of the alternator is far from saturated and the self-induction of the field circuit is sufficiently low.

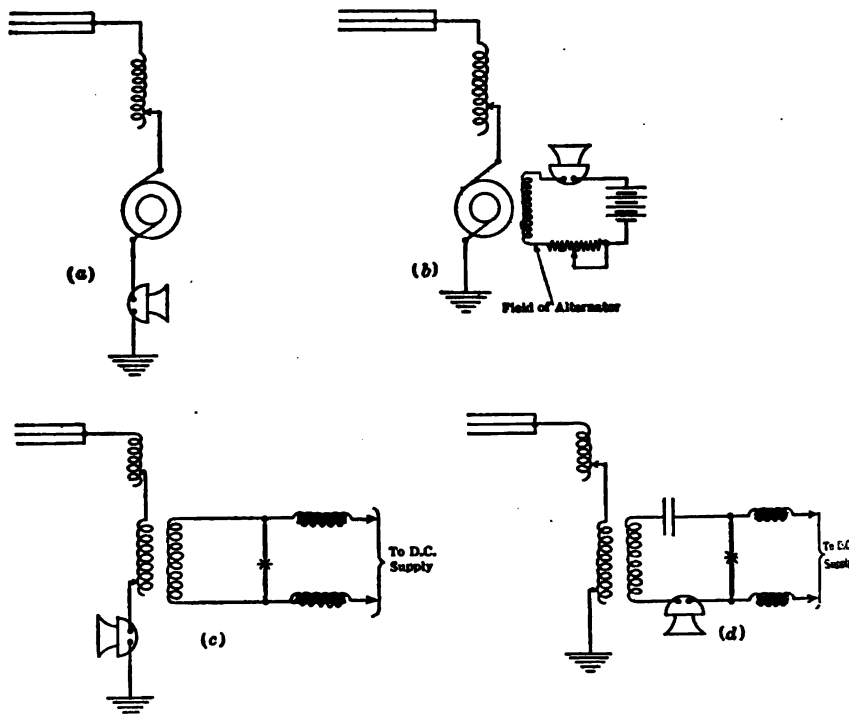

FIG. 16.—Various simple schemes for connecting the microphone to the source of power to produce modulation; none of these is used in the better types of radio-telephone transmitters, however.

The Vacuum Tube in Radio-Telephony.—Fig. 17 shows an elementary type of circuit which has been very seldom used but which illustrates the principle very well. It consists of the oscillating circuit illustrated by Fig. 126, p. 513, with the telephone transmitter connected directly in series with the antenna. Its principle of operation is exactly the same as that of the simple system illustrated by Fig. 1 except that the tube oscillator has replaced the alternator. This particular tube oscillator circuit is known as the Meissner circuit.

Fig. 18 illustrates a method of connecting the telephone transmitter in the grid circuit of the oscillator.

In this case if the telephone transmitter is idle the amplitude of the antenna current will be constant, but if the transmitter is excited by sound waves a changing current will be produced in the circuit of (1), which will produce an e.m.f. across the terminals of the coil *S*, this e.m.f. being a function of the vibrations of the telephone diaphragm. Thus the grid of the oscillator will have impressed upon it not only the high-frequency e.m.f. due to the interactions of the coils *A-B*, but also the low-frequency e.m.f. due to the

speech; the effect of this low-frequency e.m.f. is to increase or decrease the grid potential above or below what it would otherwise be if the transmitter were idle;

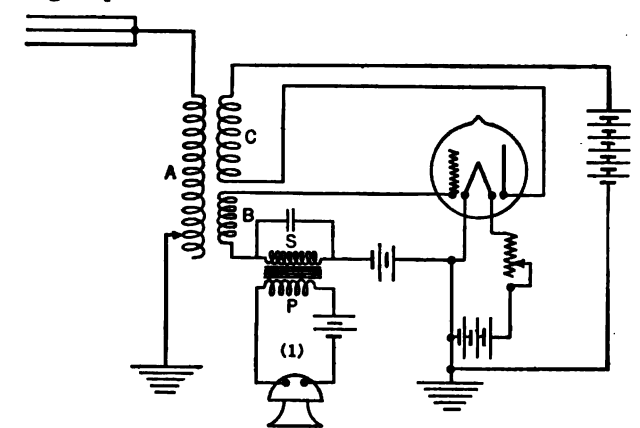

FIG. 18.—In this scheme of modulation (frequently used in low-power transmitters) the current from the transmitter circuit operates to change the average potential of the grid of the oscillating tube, thus effectively modulating the antenna current.

In this type of connection it is plain that the telephone transmitter may be of very low-power capacity; this is such an evident advantage that, as a matter of fact, practically all of the modern radiophone tube systems have their telephone transmitters connected in some such way to the grid of a tube.

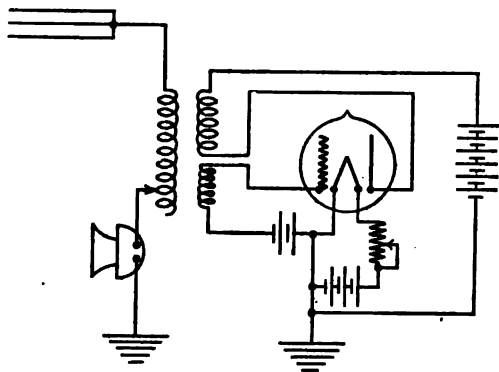

FIG. 17.—Simple circuit for telephone transmitters using a vacuum tube for power; this has been sometimes used in low power sets.

and since the grid potential reacts upon the antenna current by means of the tube and the coils *C-A*, it is plain that the amplitude of the antenna current will, instead of being constant, be changed in accordance with the e.m.f. of *S*, or of the vibrations of the telephone diaphragm.

The above two methods of telephone transmitter and tube oscillator are typical, in so far as, while they have been shown for a certain type of oscillator circuit, they may be applied in an exactly similar manner to any type of tube oscillator.

We will now discuss another type of radiophone tube connection due to Heising, wherein two tubes, or two sets of tubes, must be used; it is illustrated in Fig. 19. In this system the part to the left of the dotted line represents the oscillator circuit, which has been discussed on p. 561, Chapter VI. When the telephone transmitter is not operative the potential difference across the points Q and O is constant, and hence the amplitude of the high-frequency antenna current, as well as the plate current for

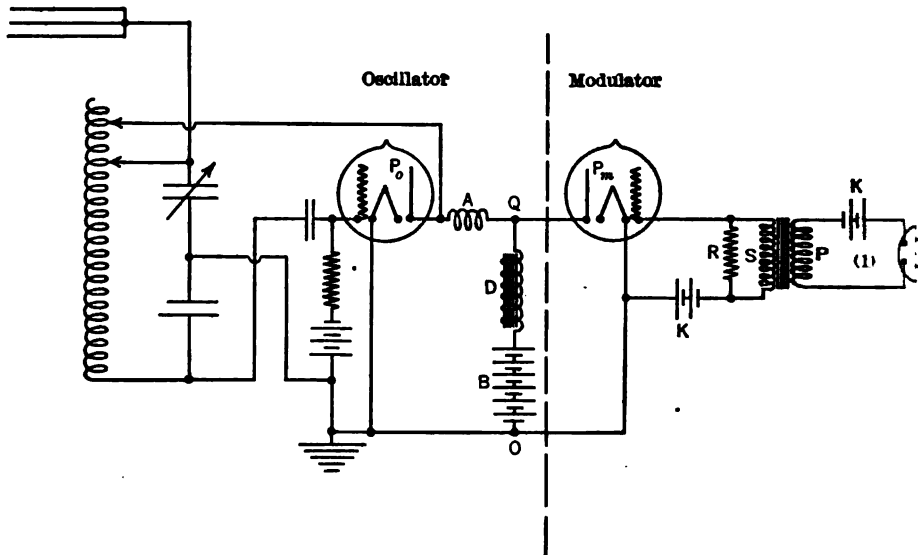

FIG. 19.—A scheme of modulation due to Heising in which a separate tube is used to accomplish modulation; the scheme has been extensively used in small transmitters

the modulator tube, is constant. However, if the telephone transmitter is spoken into e.m.f.'s are induced in the coil S , which change the potential of the modulator grid in accordance with the vibrations of the transmitter; this changes the plate current of the modulator or the current between the points Q and P_m , this change taking place at speech frequency, or audio frequency. In virtue of this the battery B will be called upon to supply a current varying at audio frequency, which current must flow through the iron-core inductance D ; since the impedance of this is very high at audio frequency, it follows that it will cause a large audio-frequency drop of potential over itself, and thus the potential difference between the points Q and O will be varied at audio frequency and in accordance

with the vibrations of the telephone transmitter. Again, since the potential difference impressed upon the plate of the oscillator (i.e., that across Q and O) is being varied, it finally follows that the amplitude of the antenna current will thereby be varied, since the amplitude of the antenna current increases with increase of the plate voltage. Thus, the vibrations of the telephone transmitter are finally reproduced in the antenna as variations in the amplitude of the antenna current or, in other words, the antenna current is thereby modulated.

The function of the coil D may be more clearly seen if the coil were assumed to be short-circuited. Under these conditions, no matter how much the modulator plate current were caused to vary by the action of the transmitter, the potential difference across the points Q and O would remain constant, and no change would be effected in the amplitude of antenna current.

The function of the choke coil A , which should be an air core coil, is to prevent the plate circuit of the modulator tube from taking from the antenna circuit any of the high-frequency power which the oscillator tube is supplying to it; the proper amount of inductance for coil A depends upon the types of tubes used, but, in general, its reactance should be considerably greater than the plate-circuit resistance of the modulator tube.

Analysis of Heising Scheme of Modulation.—This scheme of modulation is probably better than any other so far suggested, and we are therefore giving a more complete analysis of its operation.

Let us first suppose that the coil D , Fig. 19, has so much reactance that *no appreciable change* of current through it occurs due to the action of the microphone. We will assume, as has been done before, that the microphone is actuated by a sine wave of sound, and furthermore, that the sine wave of sound gives a sine wave of e.m.f. across the secondary terminals of the transformer S . (In order that the possible variation in the impedance of the grid-filament circuit of the modulating tube may not produce distortion of the terminal voltage of the transformer secondary, a high resistance R of constant value is permanently connected across the secondary to give the load circuit of the transformer an essentially constant impedance.) The potential variations of the modulator grid will cause its plate current to pass through sinusoidal variations, and will thus make the plate circuit of the modulator behave like a variable resistance connected across the points Q and O in multiple with the plate circuit of the oscillator tube. This is schematically indicated in Fig. 20, where R_{mod} represents the variable resistance of the oscillator plate circuit and R_{osc} represents the resistance of the oscillator plate circuit. Let

I_{mod} = current in plate circuit of modulator;

I_{osc} = current in plate circuit of oscillator;

I_b = current supplied by the plate battery.

If we now suppose that I_{mod} is, due to the vibrations of the microphone diaphragm, caused to change from zero to twice its average value, then,

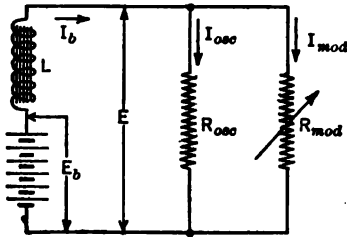

FIG. 20.—Simple representation of the Heising scheme of modulation.

since we have assumed that the coil L has such reactance as to keep I_b essentially constant, it follows that the current I_{osc} must increase and decrease about its average value to the same extent as does I_{mod} . Of course, as the value of I_{osc} is changed in response to the vibrations of the microphone diaphragm, the power given to the antenna in the form of high-frequency current must be changed and so must the amplitude of

the antenna current; in other words, modulation of the antenna current is made to take place.

The variations of some of the quantities involved in this scheme of modulation are represented in Fig. 21, where the various curves are self-explanatory; the current I_{osc} for any instant is obtained by subtracting from the essentially constant I_b the value of I_{mod} at that instant.

Now, if we investigate the variation in the power supplied to the oscillator, it will be noted, by referring to Fig. 20, that, since R_{osc} is a constant resistance the current through which is changing from zero to twice its average value, then the power expended in R_{osc} must vary from zero to four times its average value. But since the power expended in R_{osc} is equal to the current multiplied by the voltage across it, it follows that not only must the current, I_{osc} , vary from zero to twice its average value, but the voltage across it must also do the same; that is, the voltage across the points $Q-O$, Fig. 19, must vary from zero to twice its average value.

This result would seem to be contradictory to our assumption previously made that the current I_b is constant; for if I_b is constant there can be no change whatever in the voltage across Q and O . But, as a matter of fact, I_b does vary, though the amount of this variation may be small if the inductance of the coil D (Fig. 19) is large; thus it might easily be that a variation in I_b of only 20 per cent at the modulating frequency would cause the voltage across Q and O to change from zero to double its average value. In some actual radiophone sets employing this circuit we have the following:

- Average value of $I_b = 0.08$ ampere
- Inductance of coil $D = 2$ henries.
- Voltage of plate battery = 300

If, then, a maximum variation in I_b of 20 per cent should take place at a modulating frequency of 1000 cycles per sec. we would have:

$$\text{Maximum voltage drop over } D = 2\pi \times 1000 \times 2 \times 0.2 \times 0.08 = 200$$

Hence the voltage across Q and O would vary from $300-200$ to $300+200$ or from 100 to 500 .

The circuit shown in Fig. 20 is not exactly equivalent to the actual tube circuit, because in this the value of R_{osc} does not remain constant, but decreases as the voltage impressed on the tube is increased. (See p. 425, Chapter VI.) The result of this is that the variation of the power given to the oscillator is less than from zero to four times the average; but in all cases, however, the power variation is greater than from zero to twice the average.

If the power input to the antenna in the form of high-frequency current is a constant fraction of the power given to the oscillator plate, i.e., if the efficiency of the tube as a d.c.-a.c. converter is assumed constant, the power supplied to the antenna would vary about as shown in curve (h) of Fig. 21 and the amplitude of antenna current would vary as the square root of the amplitude of this power curve.

The radiophone circuits using tubes, and discussed above, are only a few of the very large number of tube systems used in radiotelephony, but they are typical of such systems, and if the reader fully understands these three he will have no difficulty in grasping any other system. It must be remembered that every such system must, to begin with, have an oscillator to produce high-frequency currents in the antenna, and, in addition, it must have some means of changing the amplitude of the antenna current in accordance with sound waves of the voice; this may be done, as has already been shown, by placing the telephone transmitter directly in series with the antenna or in the grid circuit of the oscillator tube, or, again, in the grid circuit of an additional tube, known

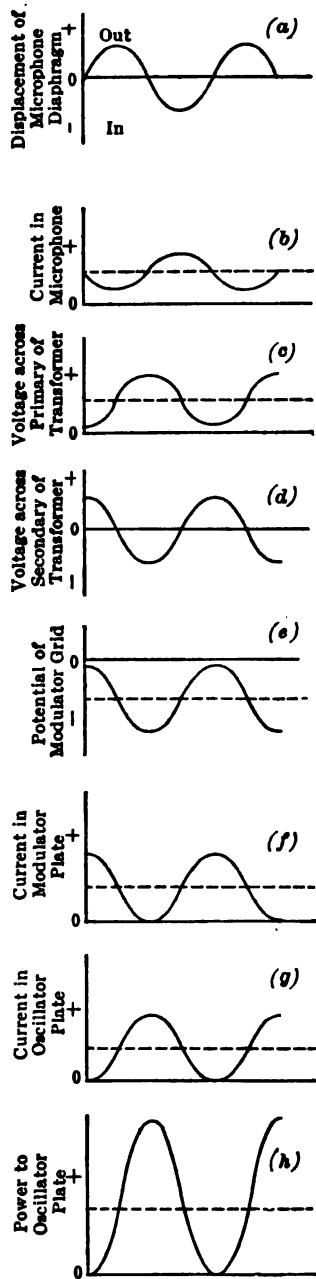

FIG. 21.—Analysis of the action of the Heising scheme of modulation.

as modulator, and which amplifies the effects of the telephone transmitter.

Requirements for Good Modulation.—The fundamental requirement for good modulation has been shown on p. 660 to be that $I^2 - I_0^2$ should be proportional to the pressure of the sound waves acting upon the microphone diaphragm, assuming the receiving circuit uses an ordinary detector. It has been stated that it is difficult and even undesirable to obtain large percentages of modulation when the transmitter is placed directly in the antenna, because of the extreme variation required in the resistance of the telephone transmitter. However, in the case of tube systems, where the transmitter is placed in the grid of either the oscillator or modulator, the change in the resistance of the microphone does not need to be so extreme; but, unfortunately, the introduction of so much other apparatus makes it more difficult to fulfill the fundamental requirement for good modulation. Thus, in the case of Fig. 19, which represents one of the more complex systems, the following conditions would need to be satisfied:

- (1) When the transmitter is spoken into, the amplitude of the displacement of the diaphragm must be proportional to the amplitude of the sound waves. This is obtained by suitable construction of transmitter.
- (2) The variation of the direct current in the circuit of (1) (see Fig. 19) must be directly proportional to the displacement of the diaphragm. Fulfilled within certain limits by suitably choosing the resistance of transmitter and impedance of primary of transformer.
- (3) The variation in the plate current of the modulator tube must be directly proportional to the variation in the grid potential of this tube; this is brought about by using the tube on the straight portion of its characteristic, hence the necessity for the use of the grid battery *K* (see Fig. 19), another use of which is to keep the plate current low, thus preventing the possibility of ionization (shown by blue glow), and to prevent the grid from taking appreciable current from the secondary of the transformer; this condition being fulfilled by having *K* of sufficient voltage that even with the loudest sounds impressed on the microphone, the grid potential does not become positive.
- (4) The action of the c.c. supply circuit (battery *B* and coil *D*) should be such that the power supply to the plate circuit of the oscillator tube should be directly proportional to the variation in plate current of the modulator tube.
- (5) The action of the oscillator tube itself should be such that the

power it supplies to the antenna is a constant fraction of the c.c. power input to its plate circuit.

- (6) Even though the modulator and power generator are acting perfectly the speech at the receiving station will be poor unless the decrements of the three tuned circuits, transmitting antenna, receiving antenna, and closed tuned circuit at receiving station are all rather high, as explained on p. 678.

In view of the many conditions to be fulfilled for correct modulation it is plain that very great care must be exercised in the use of such a circuit or similar circuits, since the non-fulfillment of one or more of the above conditions would seriously affect transmission, making the received speech drummy and indistinct.

High-power Telephone Sets Using Tube Generators.—In case a tube outfit is used for a radiophone transmitter of more than perhaps 200 watts it is necessary to use a battery of oscillators, instead of one only as shown in Fig. 19. For such an installation two tubes are arranged as modulator and oscillator (as shown in Fig. 19) but the oscillator feeds a closed circuit instead of the antenna. The battery of high-power tubes are all connected in parallel, their plate circuits feeding into the antenna and their grids, all in parallel, are excited from the closed circuit of the "pilot" oscillator which is of course modulated. These high-power, separately excited, tubes are generally called amplifiers, it being their function to amplify the modulated, high-frequency oscillations of the pilot oscillator.

In recent attempts to keep the U. S. S. *George Washington* in radio telephonic communication with the United States during the passage across the Atlantic, a combination of two tubes, modulator and oscillator, served to excite a battery of twelve large power tubes, the high-frequency output being in the neighborhood of 3 kw.

It is generally not feasible suitably to modulate the plate current of a high-power tube directly from the secondary of the transmitter-operated transformer. If the modulator is a 250-watt tube it is likely that the transmitter transformer will connect to the grid circuit of a small tube, say 5-watt capacity, and the plate circuit of the 5-watt tube will furnish the excitation for the grid of the high-power modulator.

Alexanderson's Scheme of Modulation.—Alexanderson has devised a scheme whereby the output of very large alternators may be modulated by the use of low-capacity telephone transmitter. The method used is mainly based upon the following idea. Consider the coils *A* and *B*, wound upon an iron core as shown in Fig. 22; if a direct current be sent through coil *B* then the impedance of *A* will vary according to each value of direct current. This is due to the fact that, as the direct current in *B* changes, the permeability of the iron changes and hence

the impedance of the coil A . This principle is applied in Alexanderson's scheme in the manner illustrated by the diagram Fig. 23.

L_3 in this diagram corresponds to coil B of Fig. 22, wherein a direct current is caused to flow by the battery F . L_1 and L_2 correspond to coil A of Fig. 22 and their impedance is caused to vary by the change in the direct current of coil L_3 . The magnetic circuit and the coils are arranged and connected as shown, because in so doing an alternating current flowing through L_1 and L_2 can induce but small e.m.f.'s in coil L_3 , as may be easily seen. The coils L_1 and L_2 are connected across the high-frequency alternator A , which is, in turn, connected to the antenna in the usual way. It will be noted that the circuit of the antenna and that of the coils L_1-L_2 are in multiple with respect to the alternator; since the alternator armature has impedance it is plain that by changing the

current in the circuit of L_1-L_2 the voltage across the alternator terminals is thereby changed, and hence the current in the antenna is changed. Thus, if the impedance of L_1-L_2 is made very low a large current will flow therein and the alternator voltage will fall, and so will the antenna current; the opposite takes place when the impedance of L_1-L_2 is made high. Hence, if the transmitter is spoken into, and the direct current in

current in the circuit of L_1-L_2 the voltage across the alternator terminals is thereby changed, and hence the current in the antenna is changed. Thus, if the impedance of L_1-L_2 is made very low a large current will flow therein and the alternator voltage will fall, and so will the antenna current; the opposite takes place when the impedance of L_1-L_2 is made high. Hence, if the transmitter is spoken into, and the direct current in

current in the circuit of L_1-L_2 the voltage across the alternator terminals is thereby changed, and hence the current in the antenna is changed. Thus, if the impedance of L_1-L_2 is made very low a large current will flow therein and the alternator voltage will fall, and so will the antenna current; the opposite takes place when the impedance of L_1-L_2 is made high. Hence, if the transmitter is spoken into, and the direct current in

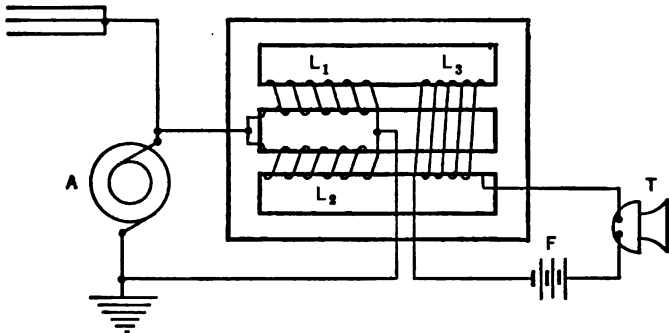

FIG. 23.—Current through coil L_3 changes the permeability of both the inside cores, thus changing the effective inductance of L_1 and L_2 , both of which are connected in parallel with the generator.

coil L_3 is thereby changed, the impedance of the coils L_1-L_2 will be changed, and the antenna current will thus be modulated.

The adjustment of the value of the direct current in L_3 , with the transmitter inoperative, has an extremely important bearing upon the operation. To begin with, it must be noted that this current may be adjusted so that:

- 1st. On increasing the current in L_3 the inductance of L_1-L_2 increases, and vice versa.
- 2d. On increasing the current in L_3 the inductance of L_1-L_2 decreases, and vice versa.
- 3d. The inductance of L_1-L_2 decreases both when the current in L_3 is increased and when decreased.

The above statements are illustrated by means of curve Fig. 24. The first condition would be realized by adjusting the direct current to I_1 , the second condition by adjusting to I_2 , and the third condition by adjusting to I_3 .

Of course, the third condition is one which cannot be used at all, and it has been found in practice that the second is the best. In this case, if the telephone diaphragm is inwardly displaced, and the direct current is thereby increased, the inductance of L_1-L_2 will decrease and the current in the antenna will decrease; so that an inward displacement of the transmitter diaphragm produces a decrease of antenna current.

Again it must be noted that the coils L_3 and L_1-L_2 must be so designed, and the direct current in L_3 must be so adjusted that a change in the high-frequency current flowing through L_1-L_2 will not produce a change in its inductance; in other words the change in the inductance of L_1-L_2 must take place only because of the change of the direct current in L_3 , and not because of the change in the high-frequency current in L_1-L_2 .

The system as actually used in practice introduces a number of condensers in the circuit of L_1-L_2 as shown in the diagram, Fig. 25. The condensers C_1 and C_2 are used in order to prevent the variations of current in L_3 from producing currents in the closed circuit of L_1-L_2 ; for, it will be found that, when the current in L_3 is changed, e.m.f.'s are induced in L_1 and L_2 in such a direction as to be additive in the circuit of L_1 and L_2 ; these e.m.f.'s would produce currents, which, by Lenz's law, would tend to hinder the change of flux being produced by L_3 . The condensers C_1 and C_2 are chosen so that they will offer a very large impedance to the flow of audio-frequency currents and very small impedance to radio-frequency currents; hence very little current will flow in L_1-L_2 , due to

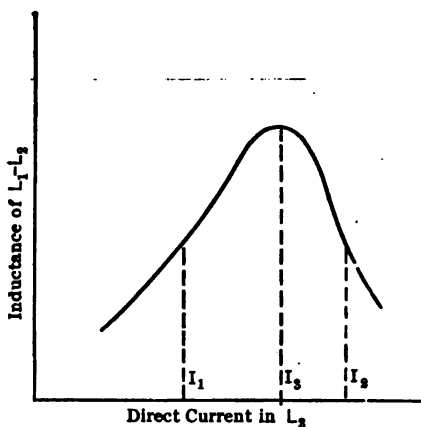

FIG. 24.—Variation in effective self-induction of L_1 and L_2 as the current in L_3 is changed.

the audio-frequency changes in the current of L_3 , while little or no opposition will be offered by these condensers to the flow of radio frequency currents from the alternator. The condensers C and C_3 are used in order to make the relation between the changes in the direct current of L_3 and

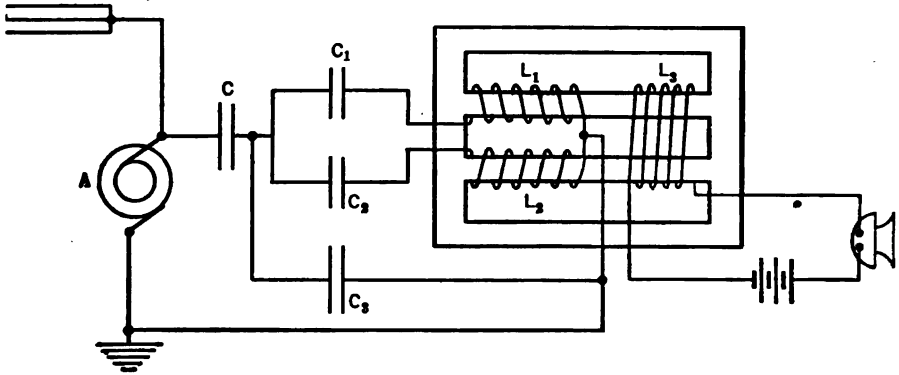

FIG. 25.—The circuit of Fig. 23 is found to function better if proper condensers are utilized as indicated in this diagram.

the antenna current a linear one through a large range of direct-current values.

It will be noted that if the condensers C and C_3 are left out, and, considering C_1 and C_2 as having an extremely low impedance to radio frequency currents, the circuit of the alternator, antenna and L_1-L_2 , may be fundamentally represented as in Fig. 26, where

- L_a represents inductance of alternator armature;
- C_a represents capacity of antenna;
- L_1-L_2 represents inductance of coils L_1-L_2 ,

while if condenser C is inserted in series with L_1-L_2 the schematic diagram would be as in Fig. 27. It is found on varying L_1-L_2 of Fig. 26 that the current in C_a (antenna current) varies but little and, for certain values of L_1-L_2 , does not vary at all; while the reverse is true of Fig. 27. This is graphically represented in the conventional curves of Fig. 28, where curve (A) has a very much smaller slope than curve (B).

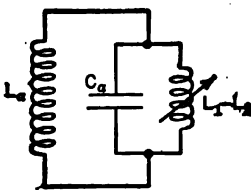

FIG. 26.—Detail circuit of Fig. 23.

In the case of curve (B), the working part would be between the points K and D . The condenser C_3 is shown diagrammatically in Fig. 29. This condenser seems to further increase the sensitiveness of the arrangement, since it forms with L_1-L_2 a multiple-resonant circuit

whose impedance is more susceptible to variations of L_1-L_2 than if this alone were used.

It has already been stated that in this system, as used in practice, the antenna current is made to *decrease* as the direct current *increases*; therefore an *inward* movement of the transmitter diaphragm may produce an *outward* movement of the receiver diaphragm, or, in other words, the displacements of the two diaphragms may be 180° apart.

The ability of Alexanderson's apparatus to modulate may be best gathered from the statement that a change in the current of the transmitter of 0.2 ampere has been made to produce a change of 37 kilowatts in the antenna power output; a three electrode tube was in this case suitably used to change the current in L_3 , the transmitter "talking" to the grid of this tube.

Receiving System.—The receiving system for radio-telephony is exactly the same as that used in receiving damped-wave telegraphic signals. It must be understood that, as pointed out on p. 649, the incoming modulated waves must be rectified and,

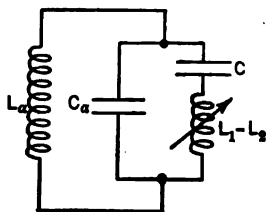

FIG. 27.—Detail circuit of Fig. 23 with a condenser introduced in the common lead of L_1-L_2 .

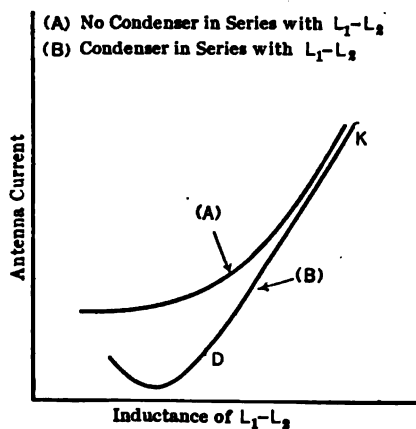

FIG. 28.—Effect of the condenser in series with L_1-L_2 on the amplitude of antenna current.

for this purpose, either a crystal detector or a vacuum-tube detector, suitably adjusted to act as a rectifier, may be used. The connections are the same as those used for receiving damped waves, and, in fact, a station fitted to receive damped waves will also receive radiotelephonic messages. One difference between the reception of damped waves and radiotelephonic messages lies in the fact that in the case of the latter, the incoming waves are undamped (in the ordinary meaning of the word), though modulated; but it must be borne in mind that in such a receiving system no local

oscillations are needed, as in receiving undamped waves for telegraphic purposes, for, while in the latter case the amplitude of the incoming waves is constant, in radio-telephony the amplitude of the incoming waves is continually changing and it is this change in amplitude which must be, and is, detected by suitable rectifying devices.

Analysis of Modulated Wave.—It is important at this point to note

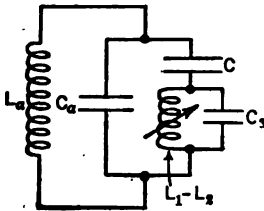

FIG. 29.—The condenser C_2 makes with L_1-L_2 a parallel resonant circuit the impedance of which varies much more rapidly with change in L_1-L_2 than does the impedance of L_1-L_2 itself.

that, though the alternator, or any other source that might be used at the transmitting station, produces, when no modulation is taking place an undamped current of constant amplitude and single frequency, except for any harmonics that might be present, yet, when modulation takes place, the current flowing through the transmitting antenna may be shown to be equivalent to a number of component harmonic currents of different amplitudes and frequencies. Thus, consider the simple case illustrated by Fig. 3 of p. 648, which represents a harmonic current, harmonically modulated.

- Let I_0 = amplitude of unmodulated antenna current;
- ω = angular velocity of unmodulated antenna current in radians per second;
- a = instantaneous value of unmodulated antenna current.

Let the equation of this current be

$$a = I_0 \sin \omega t, \dots \dots \dots (3)$$

when modulation takes place the amplitude of the current is varying between the maximum of $(I_0 + I'_0)$ and the minimum of $(I_0 - I'_0)$, and this variation takes place harmonically.

- Let ω_1 = angular velocity in radians per second of modulating disturbance, or angular velocity corresponding to the cycle represented by $A_1 - A_2$ in Fig. 3;
- i = instantaneous value of modulated antenna current.

Then, the equation of i will be:

$$i = (I_0 + I'_0 \cos \omega_1 t) \sin \omega t. \dots \dots \dots (4)$$

Eq. (2) is similar to Eq. (1) except that the amplitude of the current is now $(I_0 + I'_0 \cos \omega_1 t)$, instead of just I_0 .

Eq. (2) may be changed as follows:

$$\begin{aligned} i &= I_0 \sin \omega t + I'_0 \sin \omega t \cos \omega_1 t = \\ &= I_0 \sin \omega t + \frac{I'_0}{2} \sin \omega t \cos \omega_1 t + \frac{I'_0}{2} \sin \omega t \cos \omega_1 t \end{aligned}$$

And, adding and subtracting $\frac{I'_0}{2} \cos \omega t \sin \omega_1 t$, we have:

$$= I_0 \sin \omega t + \frac{I'_0}{2} \sin \omega t \cos \omega_1 t + \frac{I'_0}{2} \cos \omega t \sin \omega_1 t + \\ + \frac{I'_0}{2} \sin \omega t \cos \omega_1 t - \frac{I'_0}{2} \cos \omega t \sin \omega_1 t,$$

or:

$$i = I_0 \sin \omega t + \frac{I'_0}{2} \sin (\omega + \omega_1)t + \frac{I'_0}{2} \sin (\omega - \omega_1)t \quad \dots (5)$$

or, letting

f = frequency corresponding to ω ;

f_1 = frequency corresponding to ω_1 ,

$$i = I_0 \sin 2\pi f t + \frac{I'_0}{2} \sin 2\pi(f+f_1)t + \frac{I'_0}{2} \sin 2\pi(f-f_1)t, \quad \dots (6)$$

which last equation shows that the harmonically modulated current of Fig. 3 is made up of three component harmonic currents of the following amplitudes and frequencies:

Component No.	Amplitude.	Frequency.
1	I_0	f
2	$\frac{I'_0}{2}$	$(f+f_1)$
3	$\frac{I'_0}{2}$	$(f-f_1)$

Thus, if $f = 300,000$

and $f_1 = 1,000$,

then the three frequencies will be:

$$300,000, \quad 301,000, \quad 299,000,$$

which means a difference between the smallest and largest frequencies of 2000 cycles or about two-thirds of 1 per cent of the frequency of the unmodulated wave (carrier wave). On the other hand if:

$$f = 20,000 \quad (\lambda = 15,000 \text{ meters})$$

and $f_1 = 1,000$

then the three frequencies would be:

$$20,000, \quad 21,000 \quad 19,000$$

which means a difference between the smallest and largest frequencies of about 10 per cent of the frequency of unmodulated wave.

Of course, a speech-modulated current is made up of currents of a very large number of frequencies, one of which is the frequency of the carrier wave, f , and the others are

$$(f+f_1), (f-f_1), (f+f_2), (f-f_2), (f+f_3), (f-f_3) \dots \dots (f+f_n), (f-f_n),$$

where $f_1, f_2, f_3, \dots \dots f_n$ = frequencies included in the human voice.

The larger the frequencies f_1 or f_2 or $f_3 \dots \dots$ or f_n and the smaller the frequency f , the larger becomes the difference between the smallest and largest frequency expressed as a percentage of the carrier frequency.

This analysis leads us to the following conclusions:

Since the current in the receiving antenna is to be a reproduction of that in the transmitting antenna, it follows that the receiving antenna current must have the same frequencies as the transmitting antenna current. Thus, we at once conclude that the receiving antenna circuit must not be sharply tuned to any one frequency, to the partial or entire exclusion of all the others, but must be so designed as to be able to pick up all these various frequencies equally well. This means that, if the difference between the maximum and minimum frequencies, expressed as a percentage of the carrier frequency, is very large, the tuning of the receiving circuit must be *broad*, in order for it to respond equally well to a wide range of frequencies.

Again, in order for it to be possible to use a sharply tuned receiving circuit, such as may be obtained by the circuit discussed on p. 518, Chapter VI, the frequency of the carrier wave must be very high, that is, of the order of 500,000 or more, corresponding to a wave-length of 600 meters or less.

Furthermore, it would seem as if, for a receiving circuit having a certain degree of sharpness of tuning, a high-pitched voice would be less distinct than a low-pitched one; this effect is very noticeable if the proper adjustment of the receiver circuit is made.

The effect noted above is well illustrated when listening to radio-telephone transmission on long wave-lengths, say 20,000 meters; using an amplifying circuit such as shown in Fig. 127, p. 514, the tuning characteristics of which are given in Fig. 130, p. 518, the speech is very drummy, only the low vowel sounds coming through. It is quite possible to adjust the receiving circuit to such sharp resonance that the speech is unintelligible, although very loud; decreasing the coupling of the tickler coil will decrease the sharpness of resonance of the receiving circuit, making the resistance of the circuit higher. This will, of course, decrease the strength of the received signal, but at the same time will improve the quality.

In a radio-telephone outfit, both the receiving and transmitting sets of which have been properly adjusted, the speech transmission is much better than that over the average wire line; due to the fact that all fre-

quencies are attenuated alike (whereas in wire speech the high-frequency currents attenuate much more than the lower) the enunciation of the received signal is so distinct that the voice of the operator talking at the transmitting station may be easily recognized.

The Use of an Oscillating Receiving Set for Radio-telephony.—It is possible to receive speech by radio-telephony even if the receiving set is adjusted to oscillate, by suitable setting of the tickler coil (Fig. 127, p. 514). Such an oscillating receiving set requires more skill in handling and a much better transmitting set than for reception by crystal or non-oscillating tube, but to offset these difficulties it has the advantage of being *by far* the most sensitive arrangement possible. The local oscillations are adjusted to give "zero-beat frequency" with the carrier frequency of the transmitting set; it will be realized at once that the maintenance of this condition is not easy, especially if the carrier frequency is high.

The slightest variation of frequency in either the transmitter or receiver would produce a musical beat-note which would make the speech tones unintelligible. Even with a carefully designed receiver set maintaining a constant local frequency, it will be found that the average radio-telephone transmitter has sufficient variation in the carrier frequency to make this scheme unfeasible. With the lower-frequency, high-powered transmitters, having accurate frequency control, it will be found that the zero-beat reception scheme exceeds any other for sensitiveness. The tickler coil should be set with a coupling somewhat greater than the critical, otherwise the tuning of the receiving circuit is too sharp, and the higher voice frequencies encounter considerably more impedance than the lower ones, and hence the speech is distorted. The lower voice frequencies, which, combined with a carrier frequency, give frequencies quite close to the carrier frequency, come in much louder than the higher ones, making the speech a series of low-pitched vowel sounds.

With an oscillating tube for detector the rectified current is directly proportional to the impressed voltage instead of to the voltage squared, which is the case for the non-oscillating rectifier. (See p. 483.) For this type of receiver, therefore, the modulation at the transmitter should be such that the difference between the amplitude of the antenna current with the microphone in operation and that with the microphone idle should vary in direct proportion to the pressure of the sound waves on the microphone in accordance with Eq. (1), p. 659.

The oscillating receiver serves as a convenient check upon the degree of modulation at the transmitter. If the local oscillations are made to differ from the carrier frequency by several hundred cycles per second, the received beat signal should be of about the same intensity as the speech tones when the receiver is set for zero beat frequency; if the beat signal

is much louder than the speech it shows that the modulation is poor, namely, the antenna current is not being varied much by the action of the microphone.

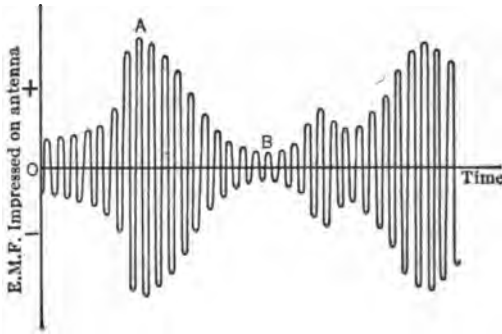

FIG. 30.—Form of voltage acting on a receiving antenna for perhaps one thousandth of a second.

Effect of Decrements upon the Quality of Received Speech.—As mentioned on p. 669, the radio-telephone speech is indistinct and drummy if the decrement of the transmitting antenna or that of either of the two tuned circuits at the receiving station is made low. This condition, it

will be noted, is exactly opposite to that required for good telegraphic communication by radio, and is therefore worth being analyzed.

It is presumed that the modulator and generator are functioning properly at the transmitting station, which means that the oscillator is impressing upon the antenna a high-frequency e.m.f., the amplitude of which faithfully follows the sound-wave fluctuations of the voice. This is indicated by Fig. 30, showing the e.m.f. impressed upon the antenna for a small part of the voice sound. Now the question arises, if such an e.m.f. is impressed upon the receiving antenna what kind of a current will flow? The elements of this problem were taken up in Chapter IV, p. 268, wherein it was shown that the current produced by a damped wave of e.m.f. impressed upon a resonant circuit depends upon two factors, viz., the ratio of the frequency of the impressed e.m.f. to the natural frequency of the circuit, and the relative value of the decrement of the impressed e.m.f. to that of the circuit itself.

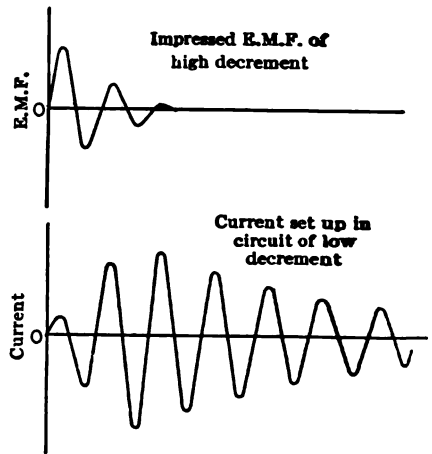

FIG. 31.—A highly damped wave of e.m.f. impressed upon a receiving circuit of low decrement will produce a current lasting much longer than the e.m.f. and of entirely different form.

If the decrement of the circuit is lower than that of the impressed

e.m.f. the current will be more sustained than the impressed e.m.f. itself. If, for example, a highly damped pulse of e.m.f. is impressed upon a circuit of low decrement and the same natural frequency as the e.m.f., the current will be about as shown in Fig. 31; the current builds up slowly and dies down slowly. We can conclude that any changes in the amplitude of the e.m.f. impressed on such a circuit will be followed but slowly by corresponding changes in current. It follows that if a modulated high frequency e.m.f. similar to that shown in Fig. 30 is impressed on a low-decrement circuit, of the same natural frequency as that of the impressed e.m.f., *though a large amplitude current will flow in the circuit, the changes in the amplitude of this current caused by the changes in the impressed e.m.f. amplitude will be comparatively small.* If, on the other hand, the decrement of the circuit is very materially increased, by adding resistance, *the current produced by the action of the modulated e.m.f. will be much smaller in amplitude than before, but the fluctuations in amplitude of the current will follow very closely those of the modulated e.m.f.*

An extreme case of this effect is illustrated in Fig. 32, wherein the impressed e.m.f. (curve *a*) is assumed to be made up of two distinct damped-wave trains. In curve (*b*) is shown the current set up by this e.m.f. in a low-decrement circuit, and in curve (*c*) is shown the current set up in a high-decrement circuit. Quite evidently, the current in the latter case very closely resembles the e.m.f. acting on the circuit, whereas the much larger current in the case of the low-decrement circuit is very far from being similar in form to the e.m.f.

The modulated e.m.f. involved in radio-telephony circuits would act on high- and low-decrement circuits in a manner similar to that indicated for the damped e.m.f. of Fig. 32; the low-decrement circuit would have large currents set up in it, but the variations in amplitude of these currents would not follow the variations in the impressed e.m.f. amplitude, whereas the high-decrement circuit would have much smaller currents (same *L* and *C* supposed as for low-decrement circuit) but the variations in amplitude would more accurately follow those of the impressed modulated e.m.f. Since the voice sounds are conveyed by the *variations in the amplitude* of the current and not by the magnitude of the current itself it is evident that the high-resistance circuit would be the one to use for successful radio-telephony.

Applying this general idea to an actual case of speech transmission, we come to the conclusion that the decrements of the transmitting antenna, the receiving antenna, and closed-tuned circuit at the receiver must all be higher than the highest decrement occurring in the modulated e.m.f. Thus in Fig. 30 the e.m.f. (which is supposed accurately to represent the voice sounds) has its more rapid change in amplitude from *A* to *B*; in ten cycles its amplitude decreases in the ratio of 1 : 10, which corresponds

to a decrement of 0.11. The decrement of none of the three circuits taking part in the transmission and reception should be as low as this value, if clear well-enunciated speech is expected at the receiving end.

For short wave work this idea is not of so much importance, because the permissible value of the decrement, from this standpoint, is lower than that generally attained in the construction of sets. Thus, if the time between *A* and *B*, Fig. 30, is taken as 0.0001 second and the wave-

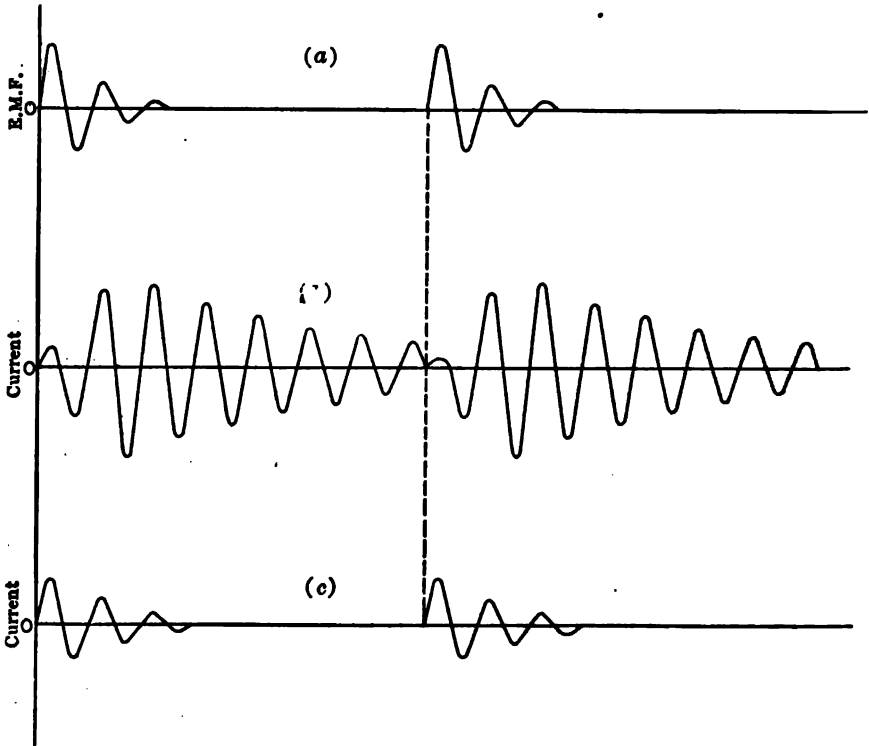

FIG. 32.—A series of damped waves of e.m.f. acting on a low resistance receiving circuit produce a current as indicated in (b), evidently not of the same form as the e.m.f. a high-resistance circuit will have currents as shown in (c) which current closely resembles the e.m.f. causing it.

length used is 300 meters, the number of cycles from *A* to *B* would be 100; a decrease in amplitude to one-tenth of its initial value in 100 cycles corresponds to a decrement of 0.023, which would be practically never obtained in either of the antenna circuits and could only be obtained in the closed-tuned circuit of the receiving set by having a tickler coupling to the plate circuit.

Multiplex Radio-telephony.—It is possible to carry on, by means of a scheme of “double modulation,” several radio-phone conversations

in the same area and using exactly the same high-frequency carrier wave for all stations; the extra complications of the scheme are worth while only in regions of congested communication.

The general idea of the scheme is conventionally indicated in Fig. 33, wherein *A* is a modulator and *B* is a long wave-oscillator; *C* is a modulator and *D* is a short wave-oscillator; the connections of a tube-transmitting set utilizing this idea are shown in Fig. 34. From these two diagrams it is evident that the antenna sends out a "doubly modulated" high-frequency wave, that is, the amplitude of the high-frequency wave follows a curve which is a voice-modulated long-wave radio-frequency. Thus generator *B*, Fig. 33, might generate oscillations of 25,000, and the amplitude of this 25,000-cycle current is voice-modulated by the action of *A*. This variable amplitude, 25,000-cycle wave, controls, through the action of modulator *C*, the amplitude of the high-frequency current generated by *D* and sent out from the antenna.

Fig. 34 shows how the Heising modulation scheme may be made to function for multiplex transmission, and Fig. 35 shows the general reception scheme for multiplex telephony. The antenna circuit and the closed circuit, L_1-C_1 , are tuned to the high frequency generated by the oscillator exciting the transmitting antenna. The action of the grid condenser and leak is to produce in the plate circuit a pulsating current, the form of which is the same as the envelope of the high-frequency wave received by L_1-C_1 . This envelope is itself of inaudible frequency, it being perhaps a voice-frequency modulated, 25,000-cycle current. This 25,000-cycle current acts on the tuned circuit L_2-C_2 coupled to the plate circuit of the first tube. The grid condenser and leak of this second detecting tube act to produce in the plate circuit of this tube (in which the telephones are connected) a pulsating current of the form of the envelope of the 25,000-cycle current. This envelope is, however, of voice frequency, and therefore makes audible the speech carried by the doubly modulated high-frequency wave.

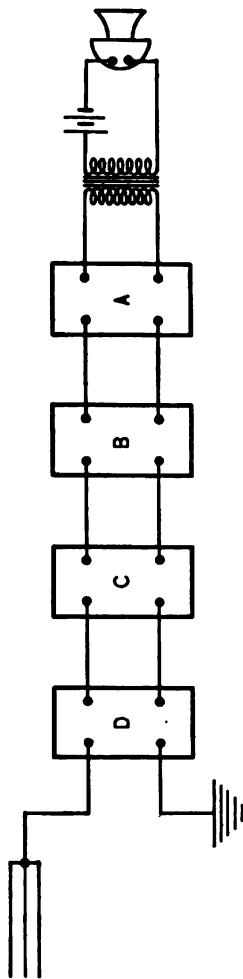
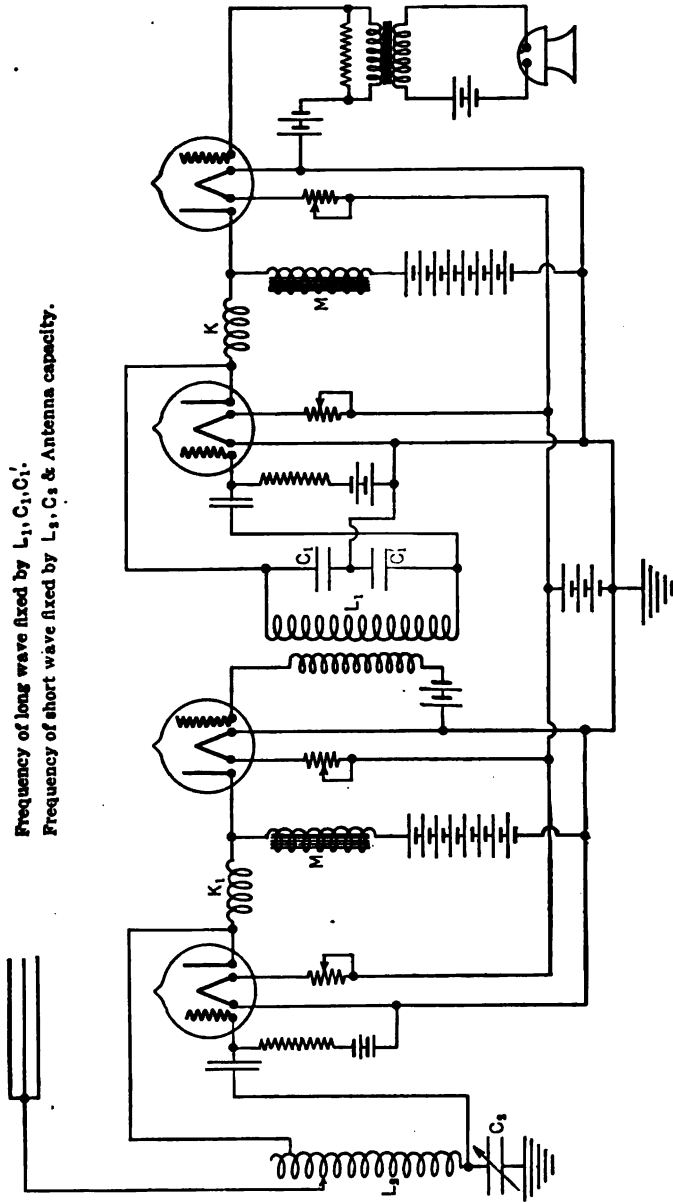

Fig. 33.—Conventional diagram of circuit for sending out a doubly modulated telephone wave.

Several stations in the same area might transmit on a carrier frequency of 3,000,000 cycles; one of the stations would send out this wave, modu-



Frequency of long wave fixed by L_1, C_1, C_2 .
 Frequency of short wave fixed by L_2, C_3 & Antenna capacity.

FIG. 24.—Arrangement of four tubes for carrying out the double modulation indicated in Fig. 33

lated by a voice-modulated 25,000-cycle wave, another would use a voice-modulated 35,000-cycle wave, another a voice-modulated 45,000-cycle

wave, etc. The selecting of the proper message at the receiving station is done by the tuning of the L_2-C_2 circuit (Fig. 35); as this is tuned to the various long-wave frequencies being used, the conversations from the several transmitting stations become audible. All receiving stations tune their respective antennas and L_1-C_1 circuits to the same high frequency carrier current.

By using several high-frequency carrier waves, far enough apart in frequency so that no interference is encountered, and using several long wave-modulations of each of these, it might be possible to carry on, in the same area, without serious interference, perhaps fifty different conversations.

Another scheme for carrying on multiplex telephony uses an antenna tuned to several different frequencies and coupled to this antenna the same number of ordinary singly-modulated transmitting sets; it seems that this scheme may be made to work satisfactorily.¹

Amounts of Power Required to Cover Distances.—As regards the distance range of radio-telephonic transmission it must be remembered that the response at the receiving end is due not to the total power in the transmitting antenna, but to the variation of this power; therefore, it might, as a general statement, be said that those formulæ would apply to radio-telephonic transmission which apply to undamped-wave telegraph transmission as given on p. 738, with the proviso that, in these formu-

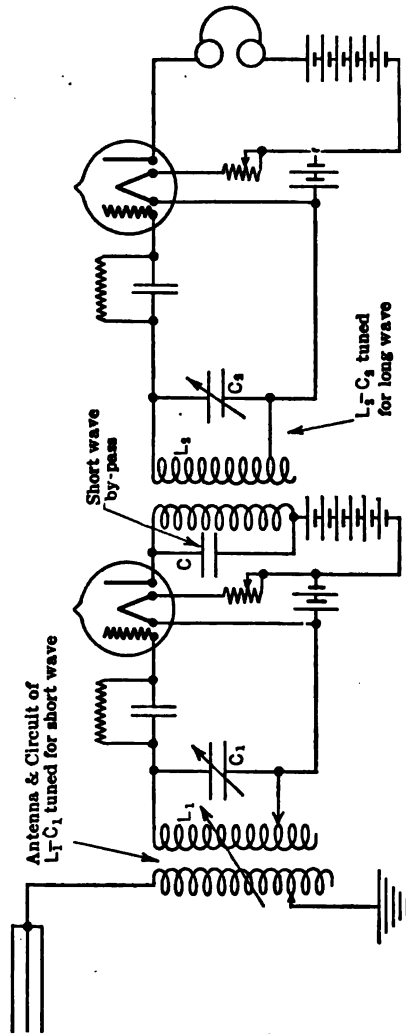

Fig. 35.—Arrangement of the receiving circuit for tuning in on a doubly modulated telephone wave.

¹ See Proc. I.R.E., Vol. VIII, No. 6, for report on the feasibility of such a scheme, article by Ryan, Tolmie, and Bach, entitled "Multiplex Radio Telegraphy and Telephony."

læ, the change in antenna current must be substituted for the antenna current itself. Furthermore, while in the case of telegraphic transmission the signals may be very faint and yet be understood by an experienced operator, in the case of radio-telephone transmission, the signals must be several times more audible, in order that speech may be fully understood, especially by an inexperienced operator.

Practically, the following have been found to be the dependable transmission ranges for a fair modulation, i.e., not less than 50 per cent:

Antenna power.	Range of reliable communication in miles.
5 watts.....	10
0.1 kw.....	50
1.0 kw.....	200
10.0 kw.....	500

As pointed out in previous discussions on the amount of power required to cover a certain distance, only very approximate values can be given. The amount of atmospheric disturbance present, the conditions of refraction, reflection and absorption, and above all the manipulative skill of the receiving operator in adjusting his receiver may change the above figures as much as 10 to 1. Thus it was possible for an antenna power of perhaps 20 kw. to transmit a radio-telephone message from Arlington, U. S. A., to Hawaii, a distance of 5000 miles, and more recently a small 100-watt set has been heard 3000 miles.

The Radio-phone Set.—We have so far considered the radio-phone transmitter and the radio-phone receiver as two separate, distinct parts. It remains to show how the transmitter and receiver are combined into a single unit constituting what may be called the "radio-phone set." The manner in which this is done depends on whether one or two antennas are used at each station.

If one antenna is used at each station the circuits are generally arranged so that the operator cannot send and receive simultaneously. A double-throw switch is then placed within easy reach of the operator so that he may, while carrying on the conversation, throw the antenna either over to the transmitting circuit, when he wishes to speak, or over to the receiving circuit, when he wishes to receive.

A conventional diagram for such an arrangement, as applied to a Heising transmitter and a vacuum-tube receiver, is shown in Fig. 36. The switch *S* connects the antenna either to the receiving circuit by means of contact *a* or to the transmitting circuit by means of contact *b*; the switch may normally be held in the receiving position by means of the spring *c*, and the operator would change over to the transmitting position by pressing down on the insulated handle of the switch.

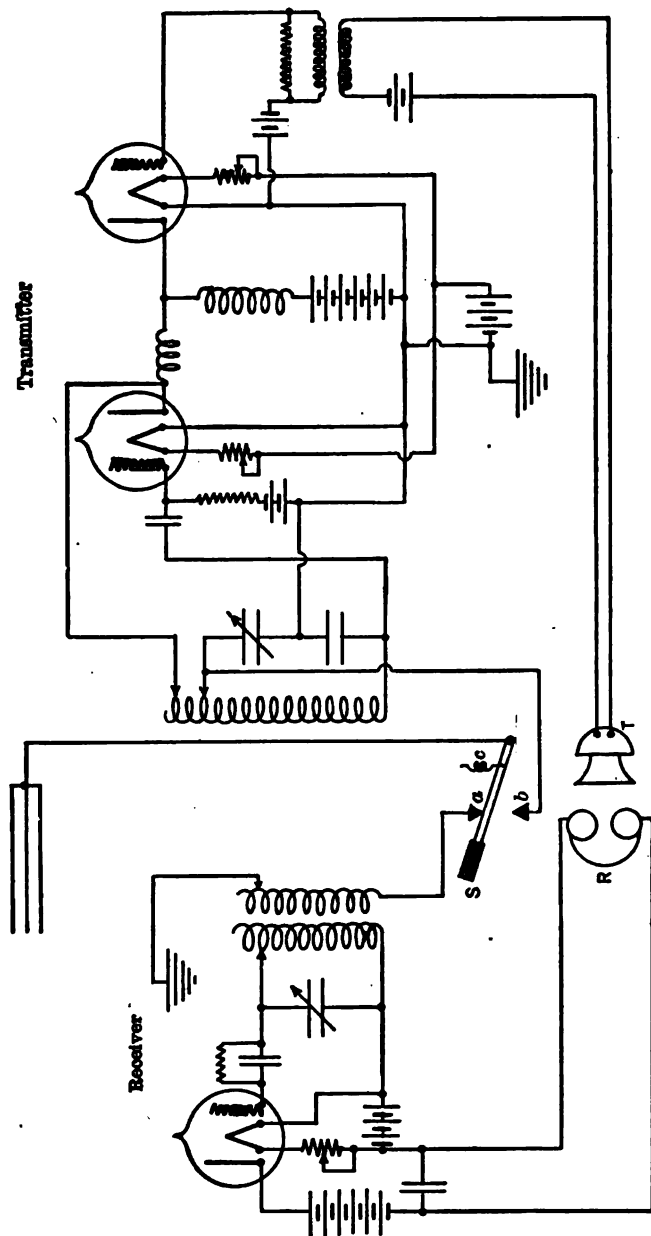

Fig. 36.—Complete circuit diagram of a radio-phonograph set; for transmitting switch *S* is thrown down, for receiving it is thrown up.

It is apparent that in a set of this kind it may often happen that an operator changes from receiving to sending before the distant operator is through talking; thus it may well be that both operators may be listening or talking at the same time. In spite of this fault the single antenna arrangement is still in use because of the simplicity and low first cost and also because a system of simultaneous sending and receiving cannot be said to have been as yet commercially developed.

Simultaneous Radiophone Transmission and Reception.—In order to overcome the difficulty encountered in the single antenna radiophone set two antennas are used at each station, one for *transmitting only* and the

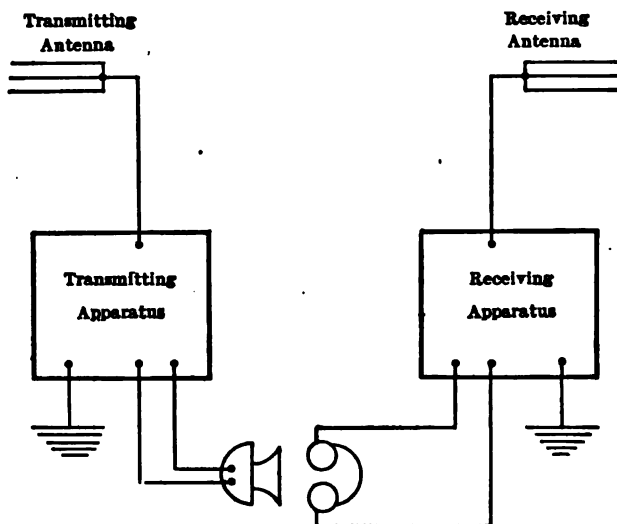

FIG. 37.—Scheme for simultaneous transmission and reception using two antennas spaced a considerable distance from one another and tuned to different wave-lengths.

other for *receiving*; each operator can then talk and listen at the same time, as is done in ordinary wire telephony. Attempts have been made to use a single antenna for simultaneous transmission and reception, but the results are not reported to have been very satisfactory. One possible scheme uses in the transmitting circuit two antennæ of identical characteristics, one a real antenna and one a dummy; adjustments are so carried out that half the power from the transmitter goes through each antenna. The receiving coil of the receiving circuit is coupled to both antennæ equally so that when transmitting practically no voltage is induced in the receiving circuit. When the distant station is transmitting only the real antenna is excited so that the signal is received all right. A brief description of such a set is given in the *Radio Review*, Vol. I, No. 15, by M. B. Sleeper.

An arrangement wherein two antennæ are used is conventionally shown in Fig. 37. The two antennæ are put up at some distance from each other and the wave-lengths of the two transmitters are made very different from each other. The reader will at once note that in such a scheme the receiving antenna has impressed upon it not only the feeble e.m.f.'s due to the distant transmitting antenna, but also the far greater e.m.f.'s due to the local transmitting antenna; the latter e.m.f.'s are not wanted, in so far as they "swamp" the smaller e.m.f.'s due to the distant transmitting antenna and make reception therefrom impossible or, at least, very difficult.

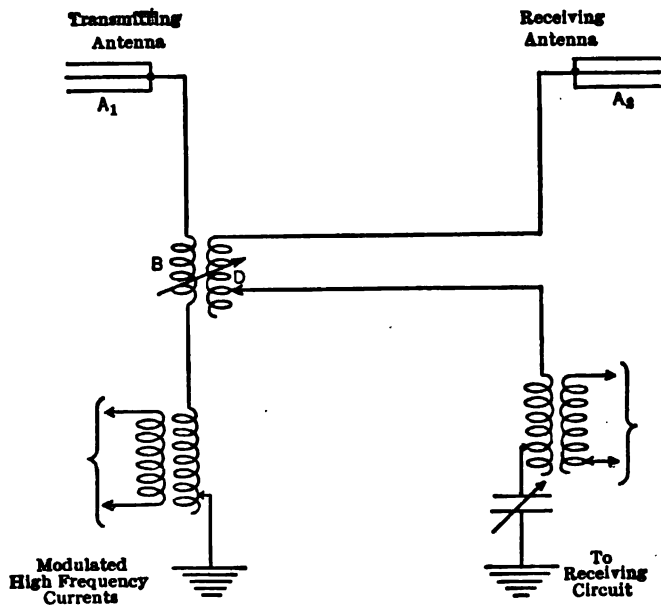

FIG. 38.—The scheme for balancing out of the receiving antenna the strong signals induced by the local transmitting antenna.

Hence, in a system of this kind some scheme must be applied whereby the e.m.f.'s induced in the receiving antenna by the local transmitting antenna shall be prevented from interfering with the signal e.m.f.'s from the distant transmitter. Such a scheme is known as a "balancing out" or "neutralization" device. A great many neutralization devices have been invented and used with more or less success. These devices may be divided into three classes:

(a) Those in which the receiving and transmitting circuits are interconnected (either magnetically or statically or both) in such a manner that the e.m.f.'s induced into the receiving antenna by the local trans-

mitting antenna are opposed and balanced out by means of e.m.f.'s induced directly by the transmitting into the receiving circuit.

(b) Those wherein filters are used to minimize the effect of the e.m.f.'s produced by the local transmitter.

(c) The "Barrage Receiver" invented by E. F. W. Alexanderson.

To class (a) belongs the simple magnetic balancing-out scheme¹ illustrated by Fig. 38, where the e.m.f.'s induced from antenna A_1 into the antenna A_2 are opposed by the e.m.f.'s induced in coil D by the currents in B . Of course the phases of these two sets of e.m.f.'s may not be exactly

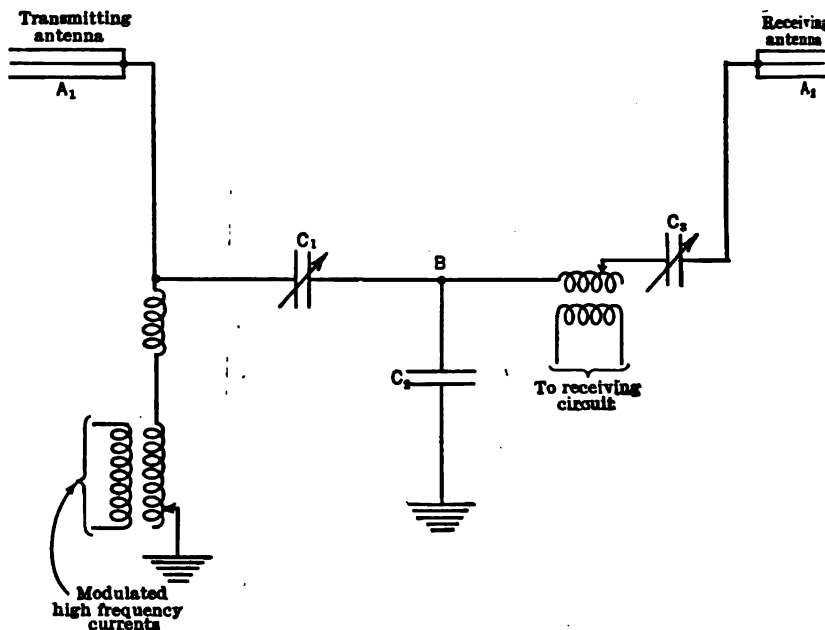

FIG. 39.—A scheme whereby the action of condensers C_1 and C_3 is utilized to eliminate from the receiving antenna the strong signals from the local transmitting antenna.

the same, in which case it is more difficult completely to nullify the action of A_1 on A_2 .

A second scheme which may be included under class (a) is Alexanderson's static balance illustrated in Fig. 39. In this case, it is endeavored to so adjust the condenser C_1 as to make the potential of the point B and that of top of the receiving antenna (A_2) due to the action of the local transmitting antenna A_1 equal to each other; if this is accomplished no currents can flow in A_2C_3B due to the local transmitter. This scheme

¹ See "Simultaneous Sending and Receiving," by E. F. W. Alexanderson, Proceedings I.R.E., Aug., 1919, and discussion.

is better understood by referring to the diagrammatic sketch of Fig. 40, wherein the two antennæ and the mutual capacity between them have been replaced by the condensers C_t , C_r , C_m .

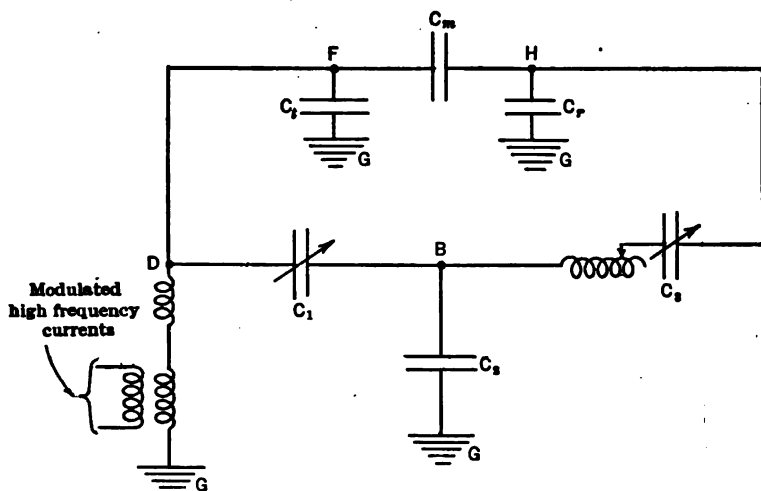

FIG. 40.—Conventional diagram of the circuit of Fig. 39.

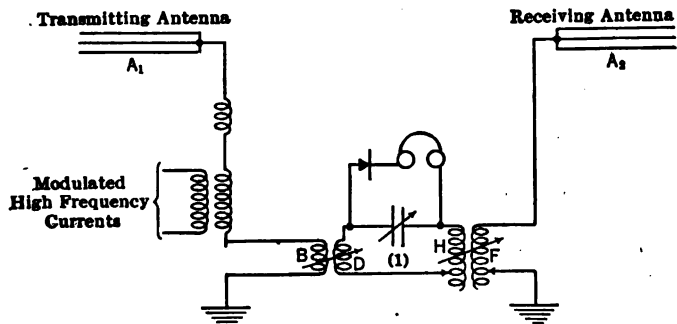

FIG. 41.—Another scheme for balancing at the local signal, by suitable coupling of the detector circuit.

In this diagram

C_t represents the equivalent capacity to the ground of the transmitting antenna;

C_r represents the equivalent capacity to the ground of the receiving antenna;

C_m represents the mutual capacity between the two antennas.

It will now be noted that starting at the point D we have the following two multiple circuits to ground: DC_1BC_2G and DFC_mHC_3G . It, there-

fore, follows that if the capacity C_1 is made equal to C_m and C_2 equal to C_r , the difference of potential between H and B will be zero and no current will flow through the receiving circuit.

A third scheme belonging to class (a) is the so-called detector balance circuit shown in Fig. 41, wherein the e.m.f.'s induced into A_2 by A_1 are caused to produce a current in the circuit of A_2 which in turn is made to induce e.m.f.'s in the receiving circuit (1) through the action of F on H ;

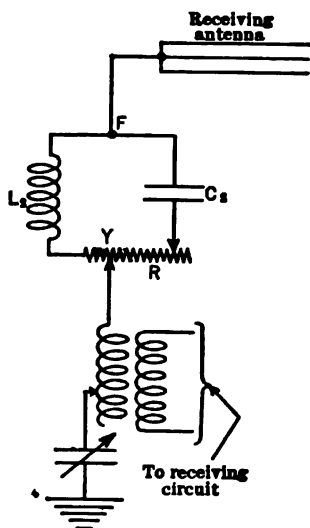

FIG. 42.—In this circuit the resonant circuit consisting of L_2 and C_1 in parallel is adjusted to give very high impedance for the frequency of the local signal, thus much decreasing its effect.

circuit is tuned to the frequency of the distant transmitter.

The "barrage receiver" invented by E. F. W. Alexanderson represents a departure from other neutralization schemes, which is claimed to be very effective. In this scheme the receiving antenna consists of two horizontal antennas stretching out in opposite directions and connected to the receiving circuit in the manner illustrated in Fig. 44. Each horizontal antenna consists of a single long wire (Alexanderson has used a wire 2 miles long laid on the ground and insulated therefrom). The circuits between P_1 and O_1 and P_2 and O_2 constitute two phase changers; these phase changers are built in the same manner as a split-phase induc-

at the same time e.m.f.'s are induced directly by the transmitter into the receiving circuit by means of the coils $B-D$; these two sets of e.m.f.'s should of course be made equal and opposite.

In all of the above schemes the neutralization is generally incomplete in view of the different phases of the opposing electromotive forces.

To class (b) belong the Infinite Impedance and the Zero Impedance circuits illustrated by Figs. 42 and 43. In the case of Fig. 42 the multiple circuit of L_2-C_2 and R may be so adjusted that the impedance between F and Y at the frequency of the local transmitter is very large and hence the local transmitter e.m.f.'s will produce but little current in the receiving circuit.¹

On the other hand in the case of Fig. 43 the circuit of $C_2R_2L_2$, which is tuned to the local transmitter frequency, presents a very low impedance to currents of that frequency, and, therefore, the e.m.f.'s due to the local transmitter produce currents in the circuit $C_2R_2L_2$ rather than in C_3L_3 , which latter

¹ For analysis of this point see Chapter I, p. 68, and Chapter IV, p. 266.

tion motor and consist in each case of two coils such as *B* and *D*, the currents through which are not in time phase due to the different power factors of the circuit of *B* and that of *D*; furthermore the coils *B* and *D* are fixed in space quadrature with respect to each other. Thus, if an alternating potential difference be impressed across the points O_1P_1 or O_2P_2 a revolving magnetic field will be produced by the coils *BD* or *FK*. By turning the coils L_5 or L_6 within the field of the respective phase changer the phase of the e.m.f. induced in L_5 or L_6 is changed, though the magnitude of this e.m.f. remains nearly the same. If, then, it is desired that the e.m.f.'s induced in the two receiving antennas by the action of the local transmitting antenna be neutralized, so as to prevent them from affecting the receiving circuit we manipulate the phase changers and the degree of coupling between L_1 and L_3 and L_2 and L_4 in such a manner that the e.m.f. induced in

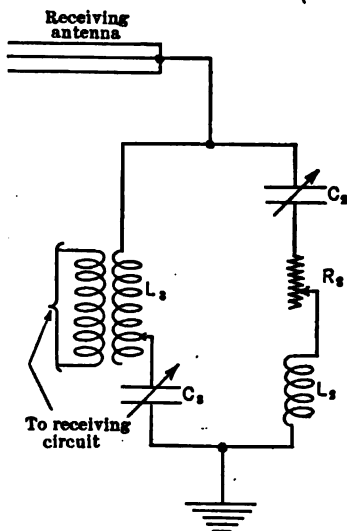

FIG. 43.—In this circuit C_1 - R_1 - L_1 offers a low impedance to ground for the local signal, thus minimizing this signal in circuit L_2 - C_2

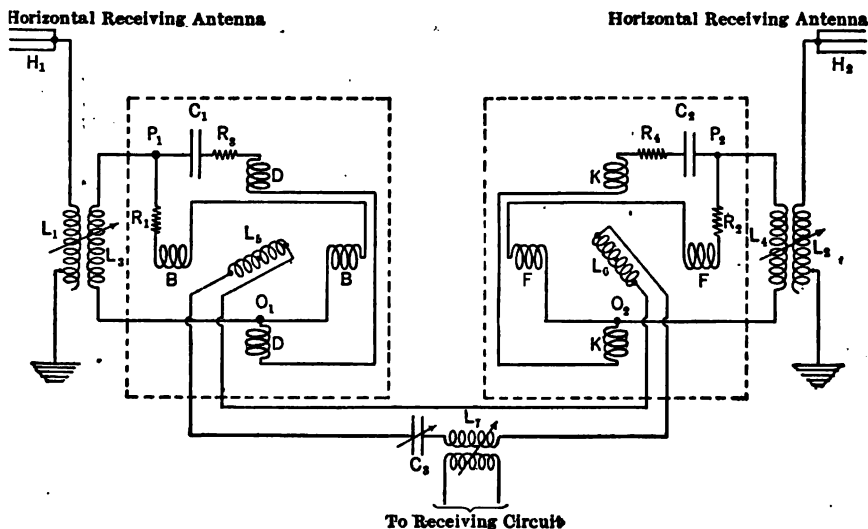

FIG. 44.—Alexanderson's so-called "Barrage receiver," it is an attempt to use rotating fields as phase changers to neutralize the local signals.

L_5 is exactly equal and opposite to that induced in L_6 . It is apparent that this may be done no matter what the phases or values of the e.m.f.'s induced in each antenna by the local transmitter may be; again, if the e.m.f.'s due to the local transmitter are neutralized those due to the distant transmitter are not neutralized because of the different phases and values for each antenna and also because of the different fre-

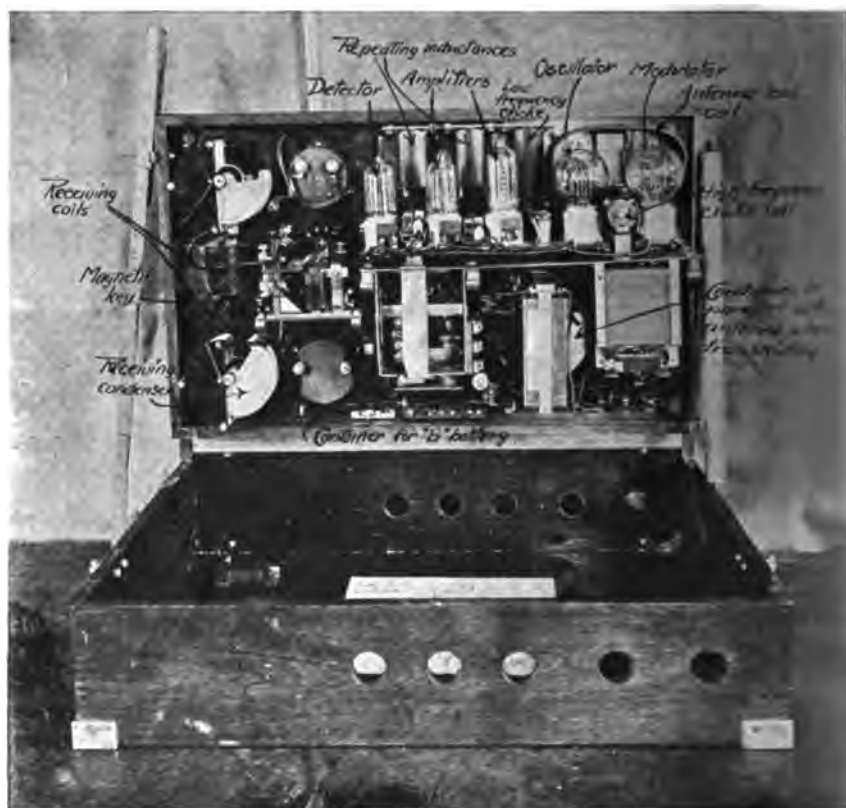

FIG. 45.—View of the construction of the set shown in Fig. 46; the set uses the Heising scheme of modulation, and has besides the receiving detector tube, two low frequency amplifying tubes, coupled by iron core inductances.

quency. In the words of the inventor such an arrangement is very effective, not only for the purpose of making simultaneous radiophone transmission and reception possible, but also for the purpose of eliminating interference from other stations.

Construction of Radio-telephone Sets.—At present radio-telephone sets are made in comparatively small powers only; about 100 watts out-

out represents the largest present commercial set. An idea of the arrangement of apparatus in a small set (output about 4 watts), may be had from Figs. 45 and 46, which show an outfit designed for communication over



FIG. 46.—Panel view of a small radiophone set.

about 10 miles distance. A 300-volt dynamotor run from a 12-volt storage battery furnishes power for the plate circuit; the various parts are sufficiently well indicated to make the cuts self-explanatory.

CHAPTER IX

ANTENNÆ AND RADIATION

Simple Antennæ—Mechanism of Radiation.—As already understood an antenna consists of one or more wires, suitably arranged, by means of which electromagnetic waves are radiated when high-frequency currents are sent into the wires.

The simplest type of antenna is the one shown in Fig. 1, consisting of two wires, *BC* and *DF* with an alternator, *A*, or some other source of high-frequency power, connected in the middle. In this arrangement one of the two wires may be considered as the "aerial," while the other performs the function of a "counterpoise." Both wires, in this case, however radiate electromagnetic waves, whereas in most arrangements the counterpoise is so arranged that it radiates but poorly compared to the aerial proper.



FIG. 1.—Theoretically the simplest type of antenna, the two wires *CB* and *DF* form the two plates of an open condenser.

The fundamental action of the alternator, as its electromotive force varies from positive to negative and vice versa, is to charge the wire *BC* positively, while, at the same time, wire *DF* is charged negatively, and, later, to reverse the charges on the two wires. It is plain that, if, say, *BC* is to be charged positively, electrons must be taken from it by the alternator and transferred to some other conductor, which, in this case, is *DF*. Again, when *BC* is charged negatively, electrons must be taken away from *DF* and transferred to *BC*. Hence the obvious necessity of having electric conductors capable of storing

electricity, or conductors with a reasonable amount of "capacitance," connected on both sides of the alternator. Thus, it would not be advisable to use the arrangement shown in Fig. 2, for, in this case, the storage capacity of *BC* would be relatively small. As pointed out in Chapter II, the capacity of such a combination (*BC* and *DF*) depends upon the surface of each conductor; if either of

them is made very small the capacity of the combination (which determines how many electrons may be transferred by the action of alternator *A*) approaches zero and the amount of radiation possible

also approaches zero. On the other hand, it is common practice to connect as shown in Fig. 3, where the ground G forms a very good second plate of the condenser, since its surface is very large, giving a reasonable capacity to the condenser made up of BC for one plate and the earth for the other.

In order to more fully understand how energy may be radiated in the form of electromagnetic waves by means of an antenna, we will first go over some fundamental principles in connection with magnetic and electric fields.

An electric field is the region wherein electric forces are manifested, and the intensity of such a field at any point is measured by the force acting upon a unit charge of electricity placed at the point in question.

Similarly, a magnetic field is the region wherein magnetic forces are manifested, and the intensity of such a field at any point is measured by the force acting upon a unit magnetic pole placed at the point in question. The lines of action of the electric or magnetic forces are called electric or magnetic lines of force and represent, at any point, the direction of the force. It is also convenient to represent graphically the intensity of the electric or magnetic

field by drawing more or less lines per unit area corresponding to a stronger or weaker field respectively; but it must be kept in mind that the force exists everywhere throughout the space in which the lines are drawn and not only at the "lines" themselves; thus the number of lines of force per unit area (electric or magnetic) which might be drawn at any point is, no matter what the intensity of the field, infinite. In other words, while it is well to visualize a field by means of lines, the significance of these lines should always be kept in mind, and it should never be forgotten that an electric field or a magnetic field is characterized by the existence of forces acting upon an electric charge or a magnetic pole respectively, and exists between the "lines of force" as much as

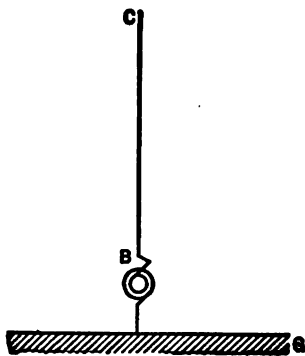

FIG. 3.—By connecting the lower end of the alternator to earth the semi-conducting surface of the earth takes the place of wire DF of Fig. 1 and enables the generator to send appreciable current up the wire BC .



FIG. 2.—Without the lower wire the capacity of the condenser is so small that the alternator could not force an appreciable current to flow in the upper wire.

it does at the point through which one of the lines passes.

Without attempting to go into the nature of a magnetic or an electric field we may say, however, that either field is accompanied by a strain in the material (ether or otherwise) present in the field, and that the forces manifested in the field may be considered as due to the elasticity of the material under stress, in much the same way that a stretched spring will exert a force because of the elasticity of the material tending to return the spring to its unstressed condition. Whatever the nature of the stresses and strains in an electric or a magnetic field, we may lay down certain well-known facts regarding them.

1st. An electric field or a magnetic field represents a definite amount of energy per unit volume of the field. It may be shown that this energy is, for the case of air, given by: ¹

$$W_m = \frac{H^2}{8\pi} \text{ ergs per cu. cm.} \quad \dots \dots \dots (1)$$

$$W_e = \frac{(\xi')^2}{8\pi} \text{ ergs per cu. cm.}$$

$$= \frac{\xi^2}{2.26 \times 10^8} \text{ ergs per cu. cm.} \quad \dots \dots \dots (2)$$

- where W_m = energy in ergs per cubic centimeter of a magnetic field;
 W_e = energy in ergs per cubic centimeter of an electric field;
 H = intensity of the magnetic field in gilberts per centimeter, or in gausses;
 ξ' = intensity of the electric field, in e.s.u. per centimeter;
 ξ = intensity of the electric field in volts per centimeter.

2d. A magnetic field in motion produces an electric field. This is nothing but the phenomenon of electromagnetic induction, for, the motion of the magnetic field induces an electromotive force, which must necessarily produce an electric stress or field. From Faraday's law, if:

- H = intensity of magnetic field in gausses;
 ξ = intensity of electric field in volts per centimeter;
 V = velocity of magnetic field in centimeters per second;
- $$\xi = VH \times 10^{-8}. \quad \dots \dots \dots (3)$$

3d. An electric field in motion produces a magnetic field.

$$H = aV\xi, \quad \dots \dots \dots (4)$$

where a = a constant of proportionality.

¹ See J. J. Thomson, "Elements of Electricity and Magnetism," 1904, p. 72 and p. 268.

This action of the moving electric field is not as easily realized as that action by which a moving magnetic field generates an electric field. Every revolving field alternator furnishes evidence of the latter effect. A revolving field depicted in Fig. 4) generates an e.m.f. in one of the armature conductors, shown at *M*; the end of the conductor, *a*, becomes + and the other becomes -, this polarity reversing when a south pole takes the place of the north pole as depicted in Fig. 4.

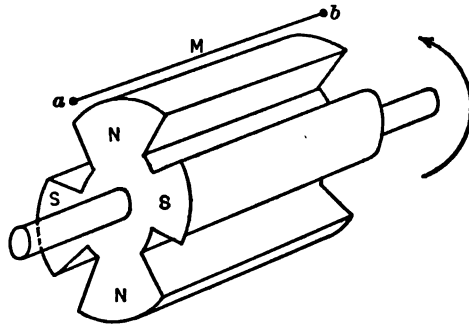

FIG. 4.—The poles of the revolving field induce an e.m.f. in the armature conductor *M*; it is important to note that the moving magnetic field will produce a difference of potential (hence an electric field) between points *a* and *b* whether the conductor *M* is there or not.

The point to be emphasized here is this—between the two points *a* and *b* (in the diagram located at the terminals of conductor *M*)

the moving magnetic field produces a difference of electric potential or e.m.f. *whether the conductor M is there or not.*

The reciprocal relation,—a moving electric field producing a magnetic

field—is not so well brought out in the action of ordinary electric machinery even through it is really the basis of every electromagnetic field. To illustrate the action let us imagine a gun shooting electrons at high speed, one following another rapidly in the same path, indicated in Fig. 5. Each of these electrons will carry with it its electric field and so at any point in space near the stream of moving electrons (*A*—

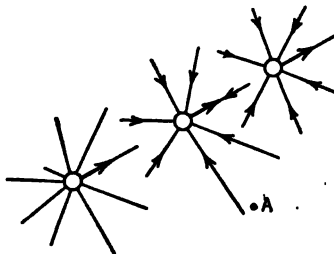
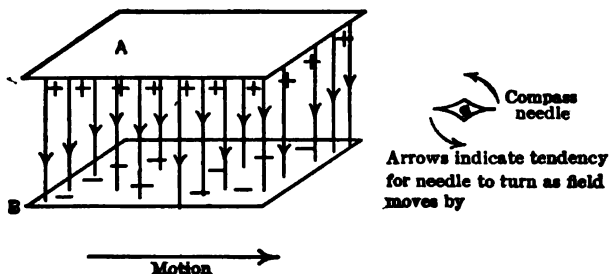

FIG. 5.—A stream of electrons shot from a gun is equivalent to an electric current and hence will produce a magnetic field at any point *A*; this magnetic field is really caused by the *moving electric fields of the electrons*. Arrow heads pointing away from the electrons indicate direction of motion.

moving electrostatic field. But we know that there will be at *A* a magnetic field (at right angles to the stream of electrons and also to the

direction of the electric field) because *this stream of electrons is really an electric current*, the magnitude of current depending upon the number of electrons passing a given point per second. Thus if there were 6.29×10^{18}



electrons passing a given point in one second, the stream of electrons would be equivalent to one ampere of current.

Upon exact analysis it will be found that the magnetic field at A, whether calculated from the well-known law of magnetic field surrounding a conductor carrying cur-

FIG. 6.—A compass needle, pivoted so that it is free to swing in the horizontal plane, will tend to set itself at right angles to the motion of the electric field as long as the electric field is moving past it, thus demonstrating the fact that a moving electric field generates a magnetic field, at right angles to itself and to its motion.

rent, or from the relation given in Eq. (4), has the same value.

To illustrate this point by another simple experiment (easier to conceive than to carry out, however), we suppose two metal plates, A and B, Fig. 6, charged so that there is an electrostatic field between them as indicated. Suppose a compass needle, oriented in the same direction as the motion of the plates, is so placed that it is situated in the electric field as the plates move by. A magnetic force will act on the compass needle tending to make it place itself at right angles to the position shown in the diagram, so long as the electric field is moving past, thus demonstrating the presence of a magnetic field as long as the electric field is moving past.

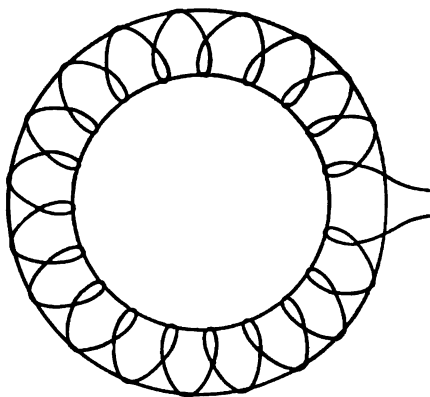

FIG. 7.—A toroidal coil is a good illustration of a closed magnetic field.

If, now, we consider a toroid such as that represented by Fig. 7 the magnetic field produced by it, when carrying a current, will be practically limited to the space within the toroid,¹ which space is not far removed

¹ This statement is not strictly true, because there is actually some magnetic field outside of the toroid as long as the current is changing. As this is an extremely small

rom the conductors of the toroid. It is plain that if the current is reduced to zero the field collapses and in so doing it moves with respect to the conductors on the toroid and induces an electromotive force therein, thus producing an electric field. In this case, since the magnetic field is very near to the conductors, the motion of *all* of the magnetic field with respect to the conductors takes place at the same time, all of the energy given to the field is returned to the circuit, and no phenomena take place other than the well-known one of electromagnetic induction.

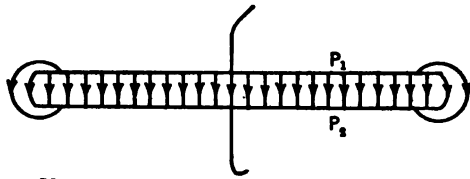

FIG. 8.—Two closely adjacent charged plates illustrate well a *closed* electric field.

Similarly Fig. 8 represents the two plates P_1 and P_2 of a condenser. The charging of the condenser produces an electric field, which is limited practically to the space between the plates. If the condenser plates are

short-circuited, the electric field will collapse and here, as in the case of the toroid, since the electric field is very close to the plates, *practically all* of the energy in the field will be returned to the circuit.

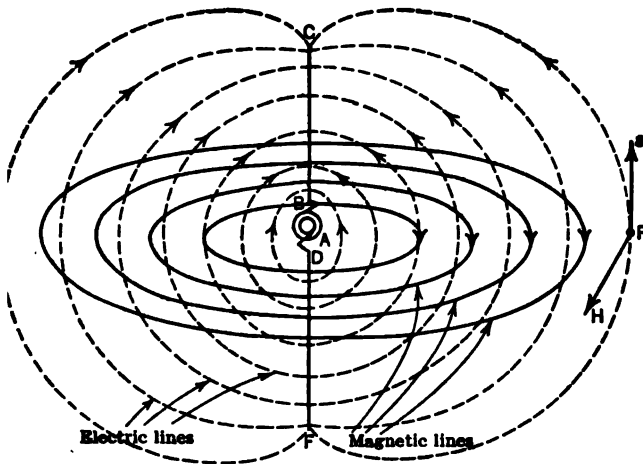

FIG. 9.—A pair of wires disposed as shown here, excited by a high frequency alternator, illustrates what are called *open* magnetic and electric fields; these fields reach out (with appreciable strength) to distances greater than the dimensions of the circuit itself.

If, on the other hand, we study the case of changing magnetic and electric fields which are distributed

to comparatively great distances away from the seat of these fields, we meet with a new phenomenon, i.e., radiation of electromagnetic waves. Thus, consider the case of the two conductors of Fig. 9, to which there is connected the high-frequency alternator A. The voltage part of the total magnetic field, however, it may generally be neglected without much error.

of the alternator is rapidly changing, and hence the charges on the conductors BC and DF are changing both in value and in sign; the result is that a rapidly changing current is flowing through the wires, and the potential difference between the wires is also rapidly changing. In view of the above the conductors are producing a rapidly changing magnetic field, the lines of force of which are circles concentric with the wires and having planes perpendicular to the wires, and, in addition, a rapidly varying electric field, the lines of force of which are somewhat as shown in the figure.

It is evident at first sight that this case is altogether different from that of either the toroid or the two-plate condenser, for, while in the latter the field (either magnetic or electric) was existent only (at least practically) in a small space near the seat of the fields and all of it could quickly return its energy to the electric circuit, in the case of the antenna both the electric and magnetic fields extend outward in all directions and to distances as great, or greater, than the dimensions of the oscillating system. It is plain, then, that here we must consider the *time* necessary for the field to reach a certain point.

It is a matter of common knowledge that a disturbance or change of either an electric or a magnetic field travels through air or vacuum with the velocity of light. Consider then a point such as P at a distance d from the antenna, and, for the sake of simplicity, in the equatorial plane.

Let f = frequency of alternator in cycles per second;
 λ = wave-length in cms.

We will first confine our attention to the electric field. Assume that the potential difference between the wires is on the point of starting from zero towards a maximum positive value and, therefore, the electric field is on the point of doing the same. The electric field at P will follow the variations of the potential difference between the wires, except that the variations at P will take place later, on account of the appreciable time necessary for the strain in the medium to travel the distance d . The line of action of the field at P will be vertical and represented by the line ξ in Fig. 9. We must not fail to remember at this point that an electric field means energy and therefore a certain amount of energy per cubic centimeter is present at the point P (due to the electric field) and the value of this energy is growing.

At some time, depending upon the frequency, the potential difference across the wires will reach a maximum and begin to diminish; and this will be followed, though at a definite time interval, by corresponding changes in the electric field at the point P , which will reach a maximum and then diminish. Since the electric field about the conductors is now decreasing it follows that the energy present in this field must be

given back to the conductors, where it will appear as energy associated with the magnetic field set up by the current caused by the collapsing electric field. It is evident then, that the energy which had at first moved from the oscillator out towards P must now return towards the conductors. However, not all of the energy given to the electric field at the point P and beyond will reach the conductors before the potential difference across them begins to build up in the opposite direction, thus again sending out energy, in the form of an electric field, in the opposite direction. There is then left¹ at the point P a certain amount of energy in the form of an electric field in the direction indicated by ξ , Fig. 9, and this energy is unable to return to the conductors since they are already sending out more energy in the form of an electric field in the opposite direction to that of ξ , Fig. 9.

The energy left at P or at any other point in the field cannot remain stationary, but must travel outward. This, however, could not happen were it not that, at the same time and for the same reason that a certain amount of energy is left detached at any point in the form of an electric field, an equal amount of energy in the form of a magnetic field, acting in a horizontal direction as shown by H , Fig. 9, also remains at each point. These two energies, moving outward with the velocity of light, can now sustain each other and are completely independent of the conductors wherefrom they issued. For, it must be here remembered that, as pointed out on p. 697, a moving electric field produces a magnetic field and vice versa. That the energies of the two fields must be equal at all points and times follows from the fact that, if one were larger than the other, the difference could not exist by itself while moving in space;² for, in so doing, it would produce the other type of energy, hence it would either have one-half of itself transformed into the other type of energy, both of which would continue to move together, or else it would be absorbed by the medium or some conductor in the path.

In the brief discussion given above we have considered energy in the form of a varying electric field acting in a *certain direction* to be detached from the antenna; but, of course, in a similar manner energy is also detached in the form of an electric field acting in the opposite direction, so that the electric field, equivalent to the energy which is detached from the antenna, is, at any point, varying continually in value and direction similarly to the antenna current. If this is harmonic the variation of the detached field will at any point be harmonic. Furthermore, since

¹ In trying to picture radiation in this elementary fashion, statements are necessarily made which will appear, to the mathematical physicist, rather crude and artificial.

² This same idea holds good for water waves also; when the two types of energy associated with the wave become unequal the wave "breaks."

it takes time for the field to travel any distance, it follows that the phase of the field will be different at each point; in other words we shall, as already outlined in Chapter III, have a wave constituting an electromagnetic disturbance in the medium, so that while at a certain instant of time the electric field in a certain portion of the space may be represented by (a) Fig. 10, the maximum intensities occurring at 1, 2, 3, a little later the electric field will appear as at (b), the maximum intensity now occurring at 1', 2', 3', and the wave of electric disturbance having traveled the distance from 1 to 1'. The above also applies to the magnetic field.

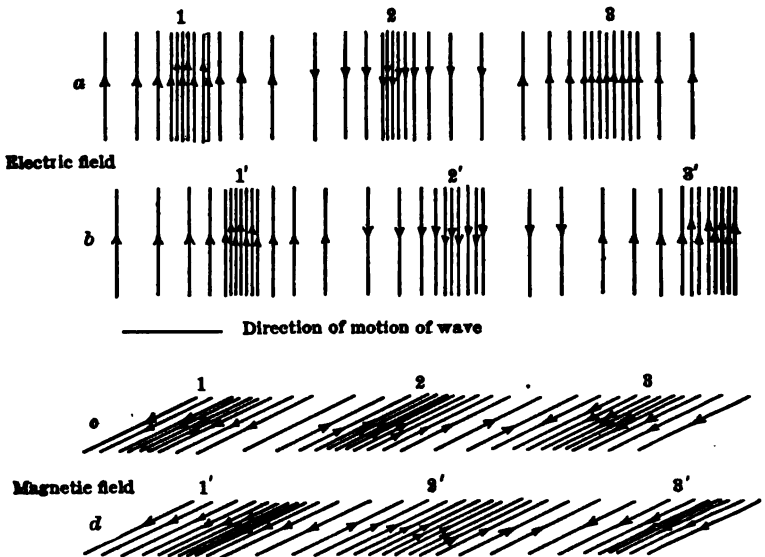

FIG. 10.—Electric and magnetic fields associated with a wave of radiation at two successive instants of time; magnetic field c occurs with electric field a, dense magnetic field occurring where dense electric field is and vice versa.—The magnetic and electric fields are in *time phase* and *space quadrature*.

the latter acting in a direction perpendicular to the electric field, and both moving together in a direction perpendicular to both. Thus, at a certain instant the magnetic field in the portion of the space for which the electric field is given in Fig. 10 (a) and (b) will be represented by (c) and (d) Fig. 10, which will correspond to (a) and (b) respectively. Since, as already stated, a moving electric field produces a magnetic field proportional to its own intensity, and vice versa, it follows that *the intensities of the two fields are in time phase*, though in *space quadrature*.

From p. 696 we have

$$\xi = VH \times 10^{-8} \dots \dots \dots (3)$$

$$H = aV\xi \dots \dots \dots (4)$$

Since in the case under discussion the electric field is produced by the motion of the magnetic field and the latter is produced by the motion of the electric field, it follows that the H and ξ of Eq. (3) are the same as the H and ξ of Eq. (4), and may be substituted therein. Thus, from (3)

$$H = \frac{\xi}{V} \times 10^8,$$

and substituting in (4)

$$10^8 \times \frac{\xi}{V} = aV\xi$$

or
$$a = \frac{10^8}{V^2},$$

and of course the second equation becomes the same as the first, i.e.,

$$H = \frac{10^8}{V^2} \times V\xi,$$

or
$$\xi = VH \times 10^{-8}.$$

In our case V , the velocity of magnetic field and of the electric field, is the velocity of light; since the velocity of light is 3×10^{10} cms. per sec. we may substitute this in Eq. (3) and thus obtain

$$\xi = 300 H. \dots \dots \dots (5)$$

From this relation we conclude that a magnetic field, of intensity represented by one gauss, when moving with the velocity of light, generates an electric field, at right angles to itself and to the motion, of the intensity of 300 volts per centimeter.

From our brief qualitative consideration of the phenomena around an antenna carrying an alternating current it follows that we may consider the space about an antenna as occupied by two components of electric and magnetic fields. One of these is continually moving backwards and forwards from the antenna, so that energy is alternately given to it by the antenna and returned by it to the antenna. Because of this backwards and forwards motion the average displacement of this component of either field is zero, and may therefore be known as the "stationary" component, also known as the "induction" field; it is this component with which students of electrical engineering are more familiar, in so far as it is this which produces the well-known phenomena of induction (either magnetic or electrostatic).

The other component of either field is the one which, once having left the antenna, is prevented from returning to it and is thereafter urged away from the antenna and continually travels outward from this with the velocity of light. This component, while fundamentally of the same nature as the stationary component, it is yet very different in so far as

it is completely detached from the antenna. It is known as the "radiation" field and represents energy which is transferred by the antenna to the medium around it, which energy is never again returned to the antenna. At any given point in space the induction fields (magnetic and electric) are out of time phase by 90° ; at the instant one of them is a maximum the other is zero. The two components of the radiation field, on the other hand, are in time phase with one another; at a given point in space the two components rise and fall simultaneously.

Both of the above types of the fields, i.e., induction and radiation exist at any point at any distance from the antenna; but at points near it the induction field is much greater than the radiation field, while at points far away from the antenna the radiation field is so much greater than the induction field that the latter may be said not to exist. The reason for this is that the amplitude of the induction field at any point varies inversely as the square of the distance while that of the radiation field varies inversely as the first power of the distance.¹ Thus any effects of the field near the antenna are mostly due to the induction field, while at great distances from the antenna they are mostly, and practically wholly, due to the radiated field. Hereafter when speaking of the field about an antenna we will, unless otherwise specified, mean to refer to the radiation field, since this is the one by means of which intelligence is transmitted to great distances without wires.

The radiation component of the field is most important when the currents in the antenna are of high frequency; but it must not be understood that no radiation component exists at low frequencies; for a radiation component exists at any and all frequencies. Since, however, the very reason for the existence of such a component is to be found in the inability of the energy given to a rapidly changing field to return in its entirety to the circuit giving out the energy, it follows that, for slowly changing fields, this effect is negligible, and hence the radiation field is practically non-existent and is never considered in low-frequency circuits.

It must not be concluded, as a result of the foregoing elementary analysis, that there are actually two different fields to be considered, one induction and one radiation. At any point in space in the neighborhood of a radiating system, the magnetic and electric fields both go through harmonic variations. Close to the radiator these two fields are both of intense amplitude (comparatively) and they are very nearly 90° out of time phase; as the distance from the oscillator increases both of these fields fall off in intensity and with increasing distance the phase difference is diminished until at very great distances (perhaps a wave-length from the radiator) the electric and magnetic field are in phase.

¹ See "Principles of Radio Transmission and Reception with Antenna and Coil Aerials," by J. H. Dellinger. Proceedings A. I. E. E., October, 1919.

This point is illustrated in Fig. 11; in (a) are shown the magnitudes of the actual electric and magnetic fields at various distances from the radiator (points supposed in the equatorial plane) and in (b) and (c) are shown the induction and radiation components of the actual field. The electric and magnetic fields are, for all conditions, in *space quadrature* (i.e., at right angles with one another) but the time phase between the two fields varies as indicated in the diagram.

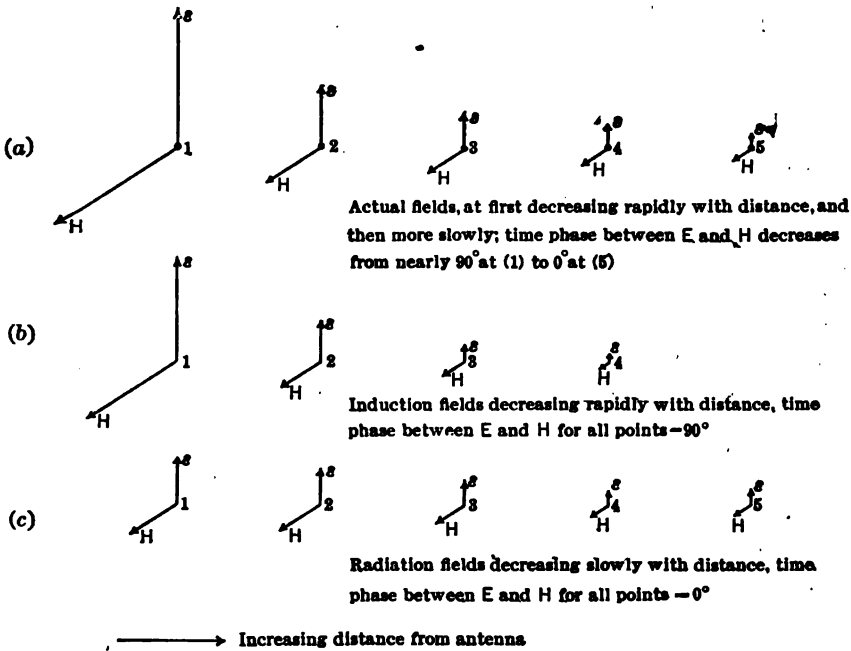

FIG. 11.—Actual electric and magnetic fields at different points in the vicinity of an antenna shown in *a*; these actual fields decrease in magnitude with distance from the antenna and at the same time come more nearly into time phase. The components of the fields which are 90° out of phase (in time) are called the induction fields, shown at *b* while the components which are in time phase with each other constitute the radiation fields, the latter decrease with the first power of the distance while the former decrease with the second power of the distance.

The above discussion has been given on the basis of the antenna and counterpoise represented by Fig. 1, but it applies equally well no matter what the counterpoise and no matter what the nature of the source which produces alternating currents in the antenna.

Radiated Field at any Distance from Antenna.—Before taking this up we will discuss very briefly the distribution of the current in an aerial. In the case of the aerial shown in Fig. 12 it is plain that, since the current in the wire *CD* flows only to charge the capacity of the wire, the effective

value of the current at *C* will be a maximum and at *D* it will be zero, for the current at *C* represents the electricity flowing through that point which goes to charge the rest of the wire, while at the point *D* no electricity whatever flows, since there is nothing to which it can flow.

On the other hand, if a metallic plate or a system of conductors be arranged at the end of the wire *CD*, as at *FG*, Fig. 13, and if *FG* has a very large capacity as compared with that of *CD*, it is plain that the effective value of the current at *D* will then be only slightly smaller than that at *C*, since the current at *D* must be such as to charge the large capacity *FG*. Under such conditions the effective values of the current in all parts of the vertical wire of the antenna will be sensibly equal and will be considered as such in the following discussion.

Consider then, the aerial as represented in Fig. 14 where the counterpoise is represented by a horizontal system of conductors, *F'G'*, laid near the ground but insulated therefrom, being in every way similar to the system of conductors at the top of aerial *FG*. The current in the vertical part of the aerial *CD* will be assumed to have the same effective value throughout, so that at every point of *CD* we will have for the equation of the current:

$$i = I_m \sin \omega t,$$

where

i = instantaneous value of aerial current in amperes;

I_m = maximum value of aerial current in amperes;

ω = angular velocity of current vector in radians/sec.;

t = time in seconds.

Under these conditions it may be shown that the radiation component of the magnetic field, at any point in the equatorial plane of the aerial, is given by: ¹

$$h = -\frac{l\omega I_m}{10Vd} \cos \omega \left(t - \frac{d}{V} \right), \dots \dots \dots (6)$$

¹ The normal development of the equation of radiation field requires more mathematical background than the average radio engineer possesses and it is not thought well to introduce it here; a short analysis of the problem is given in Berg's "Electrical

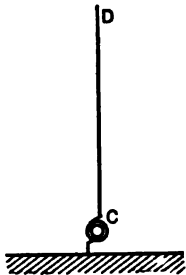

FIG. 12.—A simple vertical wire-grounded antenna.

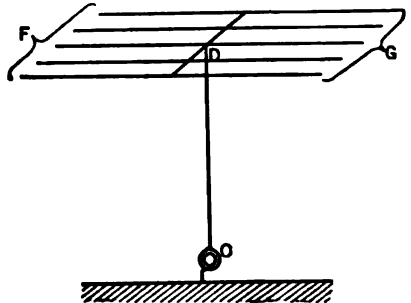

FIG. 13.—If the antenna has a considerable network of wires above the current in wire *CD* will be nearly the same in amplitude at all points of the wire.

where

- h = instantaneous value of magnetic field in gausses;
- l = height of antenna in centimeters;
- V = velocity of light in centimeters per second;
- d = distance of point in question from antenna in centimeters.

The above equation shows that the radiation magnetic field is a function similar to the antenna current (in this case a harmonic function), and that

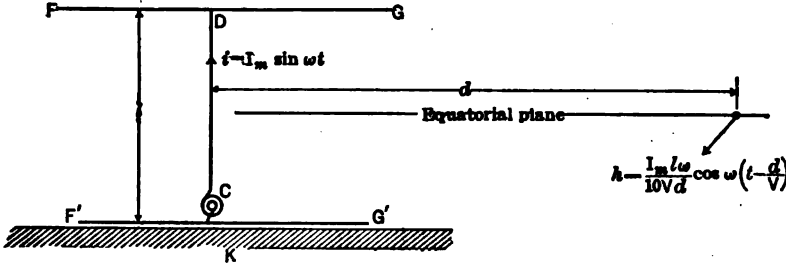

FIG. 14.—With uniform current in wire CD the magnetic field due to this current, is given as above.

the phase angle is different for points at different distances since this angle is equal to $\omega \frac{d}{V}$. Substituting $\omega = 2\pi f$ and $V = \lambda f$ we have:

$$\text{phase angle} = \frac{2\pi d}{\lambda} \quad (\lambda \text{ being measured in cm.}),$$

whence, Eq. (6) becomes:

$$h = -\frac{2\pi l I_m}{10\lambda d} \cos \left(\omega t - \frac{2\pi d}{\lambda} \right). \quad \dots \dots \dots (7)$$

Since the "radiation" component of the electric fields bears a fixed relation to the "radiation" component of the magnetic field as given by Eq. (5), we may write:

$$\epsilon = 300h = -\frac{600\pi l I_m}{10\lambda d} \cos \left(\omega t - \frac{2\pi d}{\lambda} \right), \quad \dots \dots \dots (8)$$

where ϵ = instantaneous value of electric field in volts per centimeter.

From Eqs. (7) and (8) we obtain the effective values of the radiation components of the two fields. Thus, if:

Engineering, Advanced Course," p. 278 et seq. Eq. (20), p. 289, of that volume is the same as the Eq. (6) given above, it being noted that Berg has used h to signify one-half the length of the oscillator.

H = effective value of magnetic field in gaussses;
 ξ = effective value of electric field in volts per centimeter,

$$H = \frac{2\pi I}{10\lambda d} \dots \dots \dots (9)$$

$$\xi = \frac{600\pi I}{10\lambda d}, \dots \dots \dots (10)$$

where I = effective value of the current in aerial, in amperes.

Eqs. (9) and (10) show that the effective value of either field varies directly with the effective value of current in the aerial and with the height of the aerial and inversely as the wave-length and distance from the aerial.

Now consider the case represented by a loop of wire as shown in Fig. 15. Assume, similarly to the previous case, that the capacity of the coil

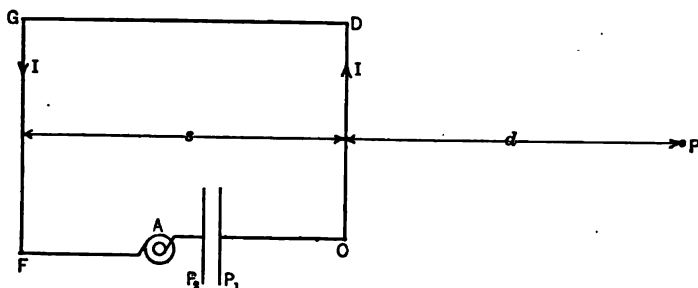

FIG. 15.—In the case of a coil antenna the magnetic field at P is calculated by adding the two fields due to CD and FG , it being noted that the currents are opposite in direction.

denser, P_1-P_2 , is so large as compared with the distributed capacity of the loop $CDGF$ that the latter has the same effective value of current throughout its length.

Consider the magnetic field at a point P at a distance d from vertical wire CD and a distance $s+d$ from vertical wire GF . Assume the positive direction of current to be as shown by the arrows. Then the field at P must be equal to the difference of the field due to CD and that due to FG .

Let h_1 = instantaneous value of magnetic field at P due to CD ;
 h_2 = instantaneous value of magnetic field at P due to FG .

Then, from Eq. (7) we have

$$h_1 = -\frac{2\pi I_m}{10\lambda d} \cos\left(\omega t - \frac{2\pi d}{\lambda}\right) \dots \dots \dots (11)$$

$$h_2 = +\frac{2\pi I_m}{10\lambda(d+s)} \cos\left(\omega t - \frac{2\pi(d+s)}{\lambda}\right) \dots \dots \dots (12)$$

It will be noted that the amplitude of these two fields is practically the same, since, for great distances, d is practically equal to $d+s$, but the phases of the fields are different by the amount

$$\pi - \frac{2\pi s}{\lambda} \text{ radians.}$$

The resultant field (h) is given by:

$$\begin{aligned} h &= h_1 + h_2 = -\frac{2\pi I I_m}{10d} \cos\left(\omega t - \frac{2\pi d}{\lambda}\right) + \frac{2\pi I I_m}{10\lambda(d+s)} \cos\left(\omega t - \frac{2\pi(d+s)}{\lambda}\right) = \\ &= -\frac{2\pi I I_m}{10\lambda d} \left\{ \cos\left(\omega t - \frac{2\pi d}{\lambda}\right) - \cos\left(\omega t - \frac{2\pi(d+s)}{\lambda}\right) \right\} = \\ &= -\left(\frac{4\pi I I_m}{10\lambda d} \sin \frac{\pi s}{\lambda}\right) \sin\left(\omega t - \frac{2\pi}{\lambda}\left(d + \frac{s}{2}\right)\right). \end{aligned} \quad (13)$$

From which the effective values of the resultant magnetic and electric fields are given by

$$H = \frac{4\pi I I}{10\lambda d} \sin \frac{\pi s}{\lambda}. \quad (14)$$

$$\xi = \frac{1200\pi I I}{10\lambda d} \sin \frac{\pi s}{\lambda}. \quad (15)$$

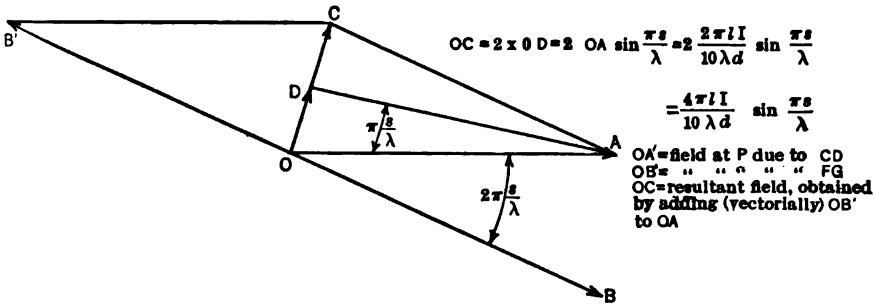

Fig. 16.—The field due to wire CD is shown by vector OA ; that due to FG is shown by OB' nearly 180° out of phase with OA . The actual field is obtained by adding vectorially OB' and OA , it being noted that they differ in phase by $\left(\pi - \frac{2\pi s}{\lambda}\right)$.

The vector addition of H_1 and H_2 by which Eq. (14) is obtained is shown in Fig. 16. These equations show that the effective value of the resultant field is equal to twice that due to either wire multiplied by the sine of an angle which varies with the distance between the two wires.

Thus if $s = \lambda$

$$\sin \frac{\pi s}{\lambda} = \sin \pi = 0$$

and if $s = \frac{\lambda}{2}$,

$$\sin \frac{\pi s}{\lambda} = \sin \frac{\pi}{2} = 1.$$

It may then be seen that if the distance between the two wires of the loop is exactly equal to one wave-length, the resultant field at all points in the plane of the loop is zero, while if the distance between the two wires is

Wire C-D

Wire F-G

Fig. 17.—At a point Y in the equatorial plane of the coil, equidistant from both wires $C-D$ and FG the radiation field is zero.

one-half a wave-length the resultant field in the plane of the loop is equal to twice that of one wire. In other words the resultant at any one point is due to fields of the same amplitude but different phase, the latter depending upon the distance between the wires, since in one case the field has to travel a greater distance than in the case of the other wire. Thus, if the two wires were close together the resultant field at any point would be zero.

Again, if a point be chosen such as Y , Fig. 17, in a plane perpendicular

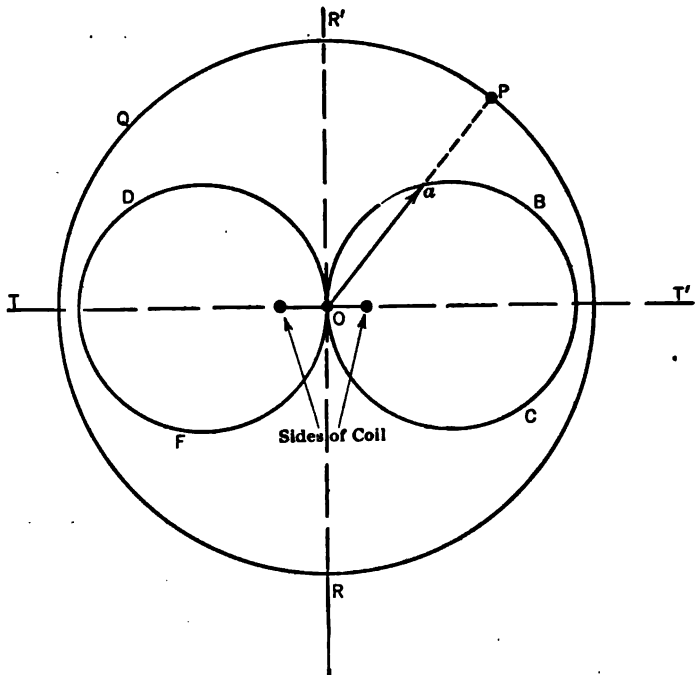

Fig. 18.—The distribution of radiation field in the equatorial plane of a coil antenna.

to the plane of the loop and equidistant from both wires, it is plain that the fields at Y due to either CD or FG must be 180° out of phase, since they have to travel the same distance, and the result is that the resultant

field at Y is zero. For points other than those such as point Y of Fig. 17 and point P of Fig. 15 the maximum value of the field for a certain distance from the aerial varies from zero at Y to a maximum at P .

If a curve were plotted to polar coordinates, showing the effective values of the magnetic field intensity at all the points around the circumference of a circle having the loop as a center, we would obtain a diagram as shown in Fig. 18, the intensity of the field at any point P along the circumference PQR being represented by the line Oa . It may be easily shown that the intensity of the field varies harmonically from zero at points R and R' to maxima at points T and T' , and, therefore, the curves OBC and ODF should be circles with a diameter equal to the intensity of the field in the direction TT' . Such a loop will, then, radiate most energy in the direction TT' in the plane of the coil and practically none in the direction RR' .

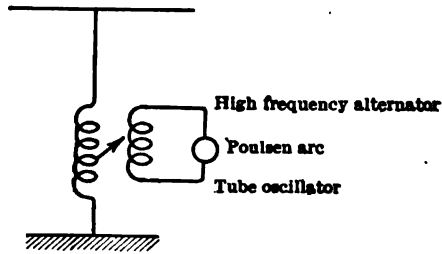

FIG. 19.—Excitation of antenna by magnetic coupling to generator.

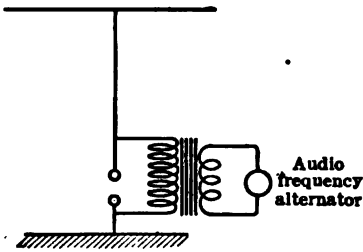

FIG. 20.—Simplest schemes for spark telegraphy excitation.

discussed simple antennæ energized by means of an alternator placed directly in series with the aerial; but it has already been stated that an antenna may be energized by means other than this one. Thus the diagrams of Figs. 19, 20, and 21 give various methods of energizing the antenna, all of which methods have already been studied. Fig. 19 shows the alternator inductively coupled to the antenna circuit, instead of having the alternator directly in the antenna circuit. This has the advantage of eliminating some of the harmonics of the alternator, so that the current in the antenna is now nearly harmonic. It

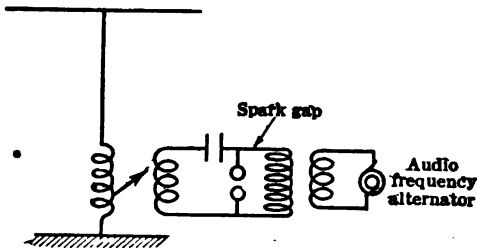
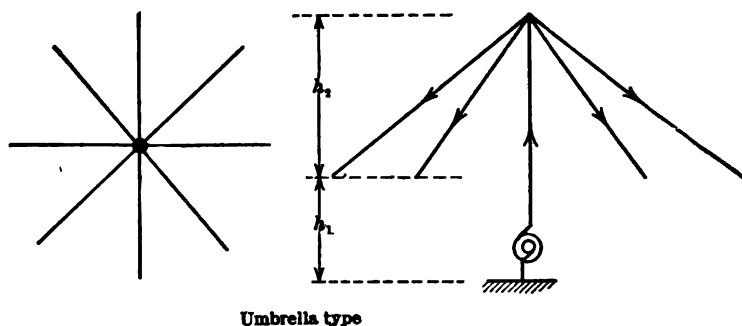

FIG. 21.—Ordinary scheme of excitation for spark telegraphy.

is to be noted that instead of a high-frequency alternator, a tube generator or a Poulsen arc may be used, and, in every case the antenna current will be nearly harmonic and undamped.

On the other hand, the arrangements of Figs. 20 and 21 are meant to produce trains of damped currents in the antenna. In Fig. 20 the



Umbrella type
FIG. 22.—Umbrella antenna.

spark gap is directly in the antenna, while in Fig. 21 the spark gap is placed in the so-called closed oscillating circuit. The disadvantage of placing the spark gap directly in the antenna is due to the fact that such a gap has considerable resistance, especially in the case of high-power, high-voltage sets where the gap distance must be large, and when so used will make the decrement of the antenna proper very high, which is

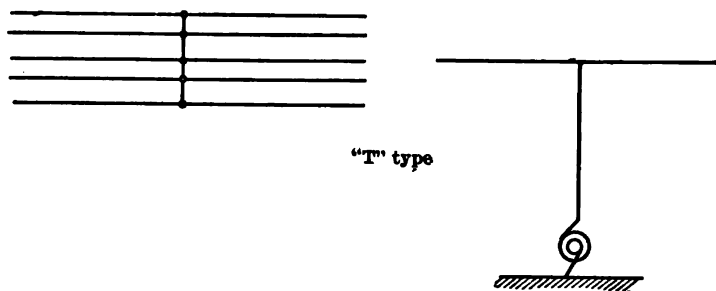

FIG. 23.—Antenna of the T type.

objectionable. Hence, with very few exceptions, i.e., low-power sets, all modern sets place the spark gap in the closed oscillating circuit, instead of in the antenna.

The methods outlined above are only typical, and there are several other ways of energizing the antenna, which have already been taken up in Chapters III, VI and VIII.

Various Types of Antennæ.—It was stated on p. 706 that if a single vertical wire be used for antenna the effective value of current at the base of the wire will be maximum, while at the top it will be zero. Since, the intensity of the field radiated by an antenna is directly proportional to the current therein (on the basis of a constant current throughout the

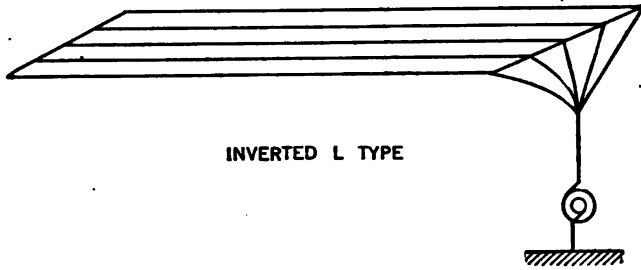

FIG. 24.—Antenna of the inverted L type.

antenna) it is plain that a single vertical wire with non-uniform current will not radiate as well as if it had a capacity at the top end, when the current would be more nearly uniform, and also larger, for a given voltage impressed by the power source. Such a capacity is used at the top end of an antenna in actual practice, the capacity being in the form of wires stretching outward from the antenna proper. Depending on how these wires are arranged we have several types of antennas, known as: umbrella, T-type, inverted L-type, "Fan or Harp" type, "Multiple-tuned" type, "Coil" type.

These various types are shown in the conventional diagrams of Figs. 22-27, respectively.

The characteristics of these various types of antennas will now be discussed.

Umbrella Type.—Since the top wires are symmetrically arranged all around the central radiator it is easily inferred that at a given distance from the aerial the intensity of the field all around the radiator is the same, that is, the curve of distribution of field intensity around the radiator should be a circle. It must be noted that, while in the case of a single wire or of a Hertzian double for a radiator, vertical wires only are used to radiate energy, in the umbrella type aerial the inclined top wires radiate

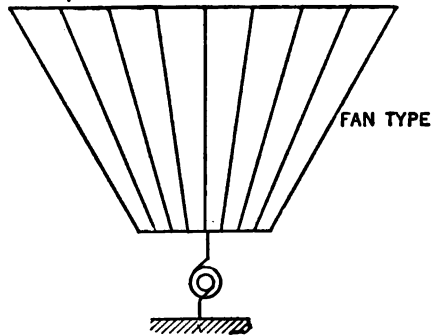

FIG. 25.—Fan or harp antenna.

a certain amount of energy in the direction perpendicular to the wires themselves. Thus, while in the former case we would likely find the intensity of the field directly over the top of the antenna practically nil.

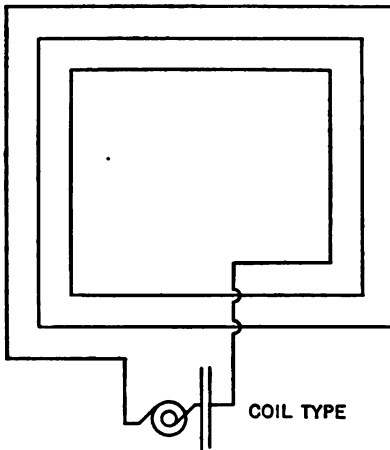

FIG. 26.—Coil antenna.

in the latter case (the umbrella antenna) the field directly over the top would be of considerable strength and is successfully used to signal to aeroplanes, even though they be directly over the antenna.

On the other hand, the top spreaders subtract, to a certain extent, from the radiating ability of the central vertical wire, for the following reason. We have already stated that the ability of the vertical wire or wires as a radiator of energy depends upon the fact that in view of its very configuration it is capable of setting up a field, magnetic and electric, which extends

to very great distances from the wire and is not mainly confined to a space near the wire; thus we have seen that in the case of the two-plate condenser of Fig. 8 the energy stored in the electric field is mainly in the space between the plates, which constitute a "closed electric circuit."

If we were to imagine an umbrella aerial with a very large number of spreaders reaching nearly to ground, as shown in Fig. 28, it is plain that these spreaders would act like one plate, and the ground like the other plate, of a closed electric circuit, and practically no energy could

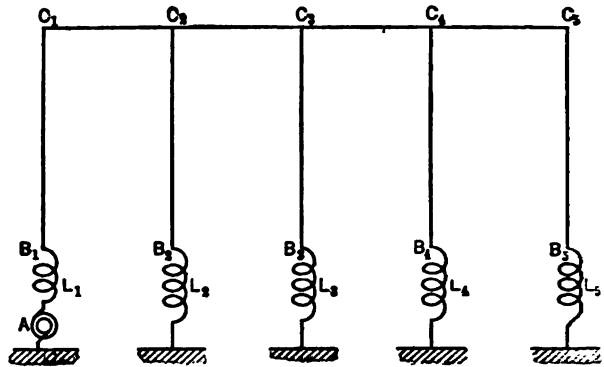

Multiple tuned antenna

FIG. 27.—Multiple-tuned antenna.

then be radiated because the electric field of the antenna would, for the most part, be confined in the space under the spreaders, and there would be little likelihood of any energy being detached from the antenna. The radiation from such an arrangement would of course

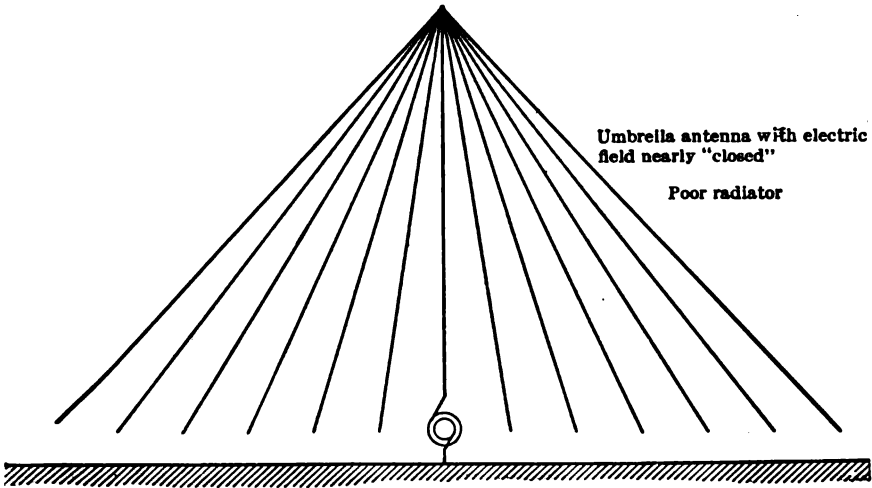

FIG. 28.—Umbrella antenna of this form is a poor radiator; the spreaders come to low.

be very small. In an actual umbrella-type antenna the spreaders do not reach to anywhere near ground, hence they do not seriously interfere with the radiation though they do so to a certain extent.

Another reason for the spreaders interfering with radiation is to be found in the fact that, at any time, the direction of the current flowing through the vertical wire is opposite to that flowing in the spreaders; that is, if the current in the vertical wire is upward that in the spreaders is downward. In the extreme case where the spreaders might be considered as being close to the vertical wire, as in Fig. 29, the portion of the vertical wire *AB* would be seriously limited in its radiating action, since the action of the current in the vertical wire is opposed by that of the spreaders.

However, the total interference of the spreaders with radiation from the vertical wire is less than what they contribute towards increasing the radiation through causing a more uniform current and, for the same voltage, a larger current, to flow through the vertical wire. Several large antennæ of this type have been used for long distance transmission. In the smaller sizes they are very convenient for portable sets where the spreaders, anchored through insulating clamps to the ground, serve the purpose of holding the central sup-

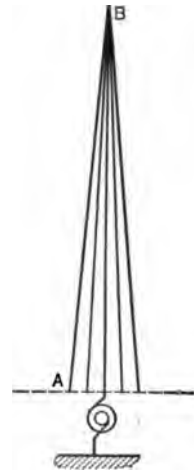

FIG. 29.—If the spreader wires are brought down very close to the antenna proper the radiation is practically zero.

port, in addition to increasing the capacity at the top end of the vertical wire.

The effect of the spreaders may be looked upon as if the height of the vertical wire had been diminished and it may be shown that the "effective height" of an umbrella antenna is approximately given by

$$h = h_1 + \frac{h_2}{3},$$

where h = effective height;

h_1 and h_2 = the heights as represented in Fig. 22.

Fig. 30 shows the arrangement of spreaders, vertical wire and vertical support, insulation, etc., for a small umbrella aerial, where *aaabbb* represent insulators and *cd* the vertical radiating wire. The spreaders are generally made long enough to extend about two-thirds the length of the mast. A large piece of wire netting (called a ground mat) may serve as a counterpoise for the oscillating system.

"T" Type.—Since the top wires are on this type unsymmetrically arranged, i.e., extending outward from the vertical wire in two directions only, it would seem at first as if the field produced by such an aerial would not be quite the same all around the antenna. This is probably the case at comparatively short distances from the aerial, but it is not found to be so at large distances away, in view of the tendency of the field to become uniform as it spreads out in all directions away from the aerial.

Here, as in the case of the umbrella type, some energy is also radiated in a direction directly above the antenna. Antennæ of this type are very widely used on shipboard where the flat top is easily suspended between two masts; also for portable sets an aerial of this type is easily suspended between two trees.

Inverted "L" Type.—The main difference between this type and the "T" type is that the "L" type has a more pronounced directional effect, that is, it is capable of producing a greater intensity of radiation in one direction than in any other. This action, in the case of the "L" antenna, is not yet very fully understood and it is by some stated to be too small to actually claim for this type of antenna directional ability. However, this type of antenna is used by the Marconi Co. for the large transatlantic stations and has actually been found to develop, even at considerable distance from it, a field stronger in the direction of the arrow Fig. 31 than in any other. This effect depends especially upon the length of the flat top, *BC*, as compared with the vertical wire *AB*. The longer *BC* is made relative to *AB* the greater seems to be the directional effect of the antenna. It is probable that this is due to an interfering action of some sort, between

the currents in the vertical and horizontal portions of the antenna, which occurs on one side of the antenna to a much greater extent than on the other. This would, of course, take place to a greater extent the larger

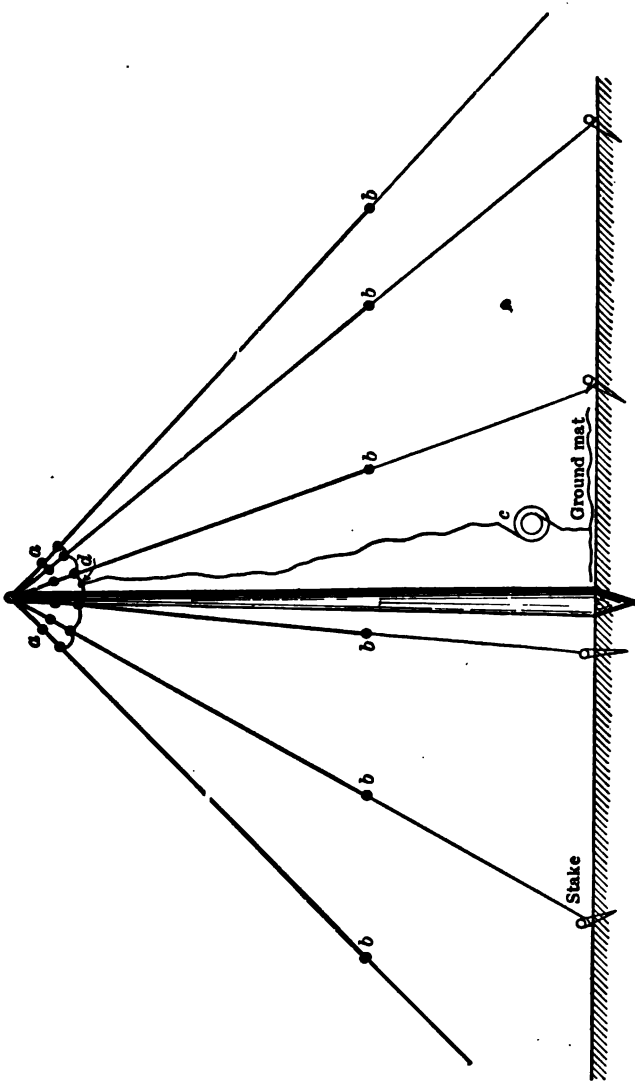

FIG. 30.—Showing construction of a small portable umbrella antenna; *a-a-a*, *b-b-b*, etc., are insulators. To get a fair "ground" a net of copper wires is generally spread out underneath the antenna, the lower side of the generator being connected to this.

the horizontal portion of the aerial relative to the vertical portion. The Clifden station of the Marconi Co. has a vertical portion about 60 meters high and a horizontal portion about 2000 meters long; it is said to have a large directional effect. In "L" type aerials as used on board ships, however, the horizontal portion is never very much longer than the verti-

cal portion and it is doubtful if in this case any appreciable directional effect is present, even at short distances from the aerial.

A directional effect is noted in the case of aeroplanes carrying a long vertical wire weighted at one end and dangling beneath the aeroplane

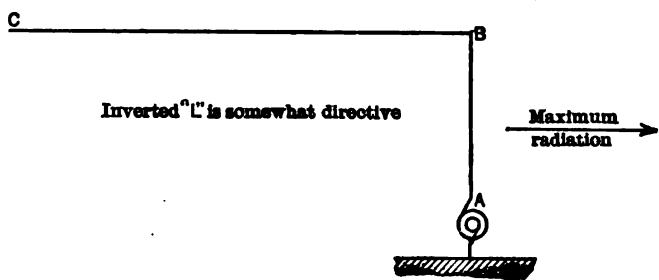
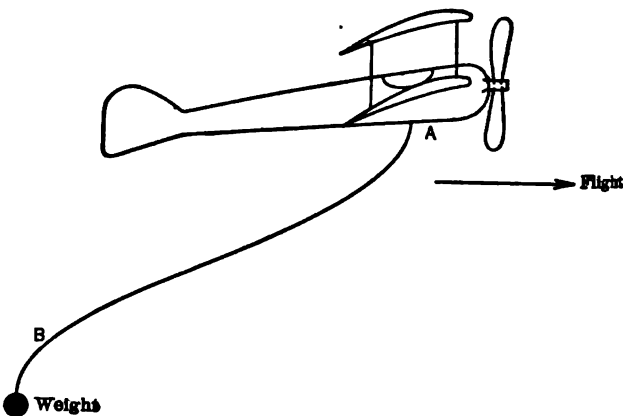

FIG. 31.—An inverted L antenna is somewhat directional giving maximum radiation in the direction shown above.

proper; this wire, when the aeroplane is in flight, bends somewhat as shown in Fig. 32 and very much in the form of an inverted "L" aerial. The greatest field intensity is in the direction of flight

or away from the horizontal portion of the aerial; in this case the framework of the plane is the counterpoise.

Not only are "inverted L" aeriels used in large transatlantic stations but they are also favorites on board ships, where they are as easily installed as the "T" type. They are also widely used for small stations and by amateurs. As regards their use on board ships it is customary to install them where the distance between the masts does not exceed about 30 meters; for over 30 meters the "T" type is used.



"Fan Type"

Aerial.—In this case a large number of vertical or

FIG. 32.—An aeroplane antenna is directional, sending out most power in the direction of flight.

nearly vertical wires in multiple are used, the top ends of these wires being perhaps free, that is not connected electrically to any other wires. In such an arrangement the effective value of the current at the base of each wire is a maximum while it is zero at the top, or, in other words the current distribution is very far from uniform, and in this respect the

arrangement is objectionable. On the other hand, the capacitance of the aerial is very large, in view of the capacitance of so many wires connected in multiple; in fact the whole arrangement may be thought of as a single wire having a capacity equal to that of all the wires. The current through the combination of all the wires may, because of the large capacity, be made very large without excessively high voltages. Another advantage of this type of aerial as compared with the others previously discussed is that there are no horizontal or inclined wires to interfere with the radiation from the vertical wire. As a matter of fact such an arrangement is considered one of the best and most efficient radiators. In spite of this, however, the fan type is not very widely used because of the difficulty of installing it, especially in the case of ships where such a multitude of vertical wires would be in the way of some of the projecting parts of the ship.

“Multiple Tuned” Type.—This type is of recent conception and has been used for the New Brunswick, N. J., station. It consists, as shown in the diagram Fig. 27, of a horizontal top similar to the top of “T” antenna, fed at one end by means of the alternator A connected in series with the tuning inductance L_1 , and the vertical wire B_1C_1 , and in addition of a number of vertical wires attached to the horizontal top at suitable points and each separately connected to ground through a tuning inductance. The result of this is that each of the vertical wires acts as a vertical antenna, the whole arrangement constituting a number of vertical antennæ connected in multiple, and hence radiating as if they were a single antenna. The advantage lies in the fact that, since each vertical wire is independently connected to ground, it follows that all the ground resistances are connected in multiple, and hence the total ground resistance is very much less than would be found to be the case with any other type of antenna of the same power capacity, thus giving a very high efficiency.¹

Of course it is hardly necessary to mention that the phases of the currents must be adjusted so that all the vertical wires will be radiating in phase with one another in order to obtain maximum radiation; the tuning coils L_1, L_2, \dots, L_5 are used for the purpose of making this adjustment.

On the other hand, if the vertical wires be suitably spaced and if, in addition, the phases of their currents be suitably adjusted it is said to be possible by means of this type of antenna to obtain greater radiation in one direction than in another thus producing directional transmission.

¹ It must be pointed out here that the radiation resistance of each vertical wire of the multiple-tuned antenna cannot be calculated as though the wire stood alone, using e.g. Eq. (21), p. 737. The presence of the other vertical wires, also carrying current, will affect this radiation resistance, the amount of this effect depending upon the proximity of the various vertical wires, and upon the relative phases of their currents.

Thus, in the case of the multiple-tuned antenna the intensity of the radiated field at any point is the resultant of the fields due to each of the vertical wires and, if suitably designed and adjusted, the resultant field in certain directions may be made a minimum and in others a maximum, thus producing a directional effect.¹

An elementary analysis shows the normal operation of this antenna to be but slightly directive, the maximum radiation taking place at right angles to the length of the antenna. If directive radiation is obtained by phase shifting in the different vertical wires, the radiation resistance of the antenna as a whole falls to a small fraction of its normal value.

"Coil Antenna."—This has already been discussed on p. 708, where it was shown that such an aerial has a very decided directional effect and that the intensity of the field in the plane of the coil, where it is a maximum, is a function of the distance between the two vertical sides of the coil and is greatest when this distance is equal to one-half a wavelength. A comparison may here be made of the single vertical wire with uniform current throughout and of the coil antenna with uniform current throughout. Thus, from Eqs. (9) and (14) on pp. 708-709 for the effective values of the intensity of the magnetic field at any distance from antenna we have:

$$H = \frac{2\pi l I}{10\lambda d} \dots \dots \dots (9)$$

for single wire

$$H = \frac{4\pi l I}{10\lambda d} \sin \frac{\pi s}{\lambda} \dots \dots \dots (14)$$

for coil of one turn. Of course, if the coil aerial has more turns than one the intensity of the field is directly proportional to the number of turns, provided that the current is uniform throughout.

If N = number of turns

$$H = \frac{4\pi N l I}{10\lambda d} \sin \frac{\pi s}{\lambda} \dots \dots \dots (14a)$$

for coil of N turns.

If I , l , λ , and d are the same for the two types of antennas we may obtain the ratio of the magnetic fields due to the coil and to the single wire by dividing (14a) by (9). Thus,

¹ See paper by E. F. W. Alexanderson, "Transatlantic Radio Communication," A. I. E. E., Proceedings, Oct., 1919. In reading this paper the student should bear in mind that the quantitative results predicted (magnitudes of currents, etc.) do not hold good for the transient state which, in an antenna of this kind, may be a large fraction of the duration of a "dot."

Ratio of field of coil to that of single wire

$$= 2N \sin \frac{\pi s}{\lambda}.$$

In order to make the two fields the same we must have

$$\sin \frac{\pi s}{\lambda} = \frac{1}{2N},$$

or

$$s = \frac{\lambda}{\pi} \sin^{-1} \frac{1}{2N}.$$

Below is given a table showing the value of s for different values of N .

TABLE I

Distance between sides of a coil aerial of the same height as a corresponding single vertical wire aerial necessary to make the fields from the two aerials alike.

N	s
1	0.17 λ
2	0.08 λ
3	0.053 λ
5	0.032 λ
10	0.016 λ
100	0.0016 λ

It is understood that the coil aerial field has, in the above discussion, been considered which exists in the plane of the coil, i.e., the plane of maximum field intensity. The above table shows that for a single turn coil aerial the width must be as large as 0.17λ in order for it to have an effect equivalent to that of a single wire of the same height. But with a larger N the width may be made much smaller, so that with a 100 turns the width need only be a few meters, even with large wave-lengths. However, with a large number of turns the question of the capacity between turns and the effective resistance of the coil plays an important part.

If the capacity from turn to turn is large (i.e., the turns close together) the current will not be uniform throughout, and, furthermore, the phase of the current at every point will be different, a condition which is not conducive to best results as regards radiation. Hence the turns should be separated by a considerable distance from one another. This may be stated by saying that the capacity of the coil itself should be such as to make the fundamental wave-length of the coil no larger than

about one-third of the wave-length to be used. The effective resistance of the coil antenna is taken up on page 737 of this chapter.

As examples of coil antennæ which seem satisfactory for receiving purposes it may be noted that for a 600-meter wave a square coil, 120 cm. on a side, of 10 turns, spaced about 0.5 cm. from each other, requires a tuning condenser somewhat less than $.001 \mu f$.

By installing the coil (or "loop" as it is more frequently called) as indicated in Fig. 33, it may be used with the *D. P. D.* switch down

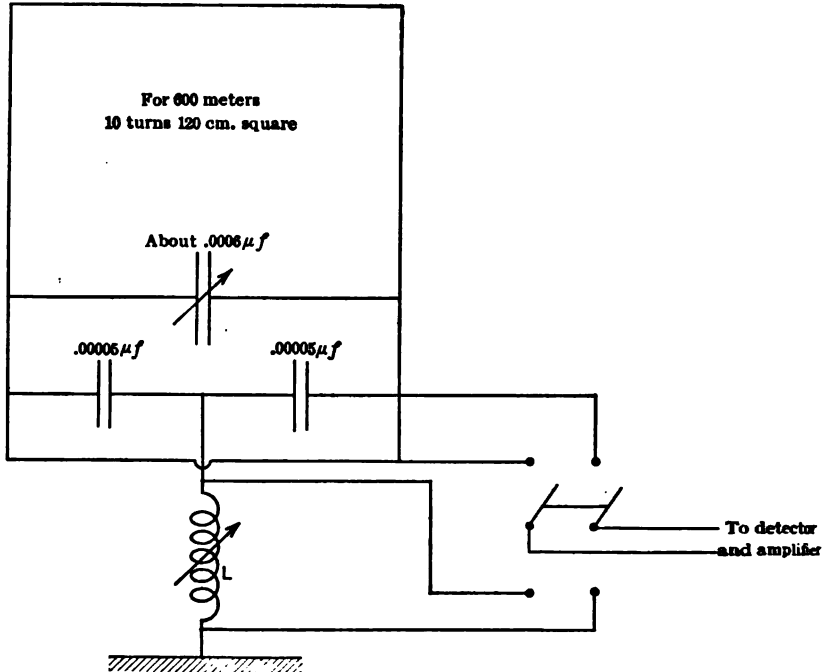

FIG. 33.—Use of a coil receiving antenna; by throwing the switch down the coil acts as a simple antenna, the coil *L* being used for tuning. When it is desired to get the directional effect of the coil the switch is thrown up.

for general reception, the loop merely acting as a low antenna, tuning being accomplished by the variometer; *L*. When the desired signal is received the switch may be thrown upwards and the directive effect of the coil thus be obtained.

For wave-lengths from 10,000–20,000 meters a square coil about 6 meters on a side with 50 turns spaced 4 cm. apart is suitable.

Because of the comparatively low receptive power of loop antennæ the receiver (detector) used must be the most sensitive available; the use of such a detector with a good amplifier is possible because of the comparatively low intensity of the "strays" picked up by a loop.

Aeroplane and Airship Antennæ.—The aerial system of aircraft comes nearest to approximating the conditions represented by the simple aerial system of the Hertzian double (see Fig. 1), in so far as the counterpoise is not the ground, and furthermore the antenna and counterpoise are at considerable distance from the ground, so that the electromagnetic waves generated by such a radiating system travel outward in space without coming in contact with the ground except at considerable distance from the radiating system.

The various types of radiating systems used may be classified into two general headings:

- (1) Those which may be used only when the ship is in flight.
- (2) Those which may be used at any time whether the ship is in flight or not.

The first class includes by far the most effective type of aircraft aerial; in this case the aerial is a trailing wire dangling from the aircraft while the counterpoise consists

of all the metal parts of the craft electrically connected together. The trailing wire is made up of a length of phosphor bronze or silver bronze wire ranging between 150 and 300 feet with a weight attached at its free end and dangling from the aircraft somewhat as shown in Fig. 32. The transmitting or receiving apparatus is connected between the trailing antenna wire and the metal

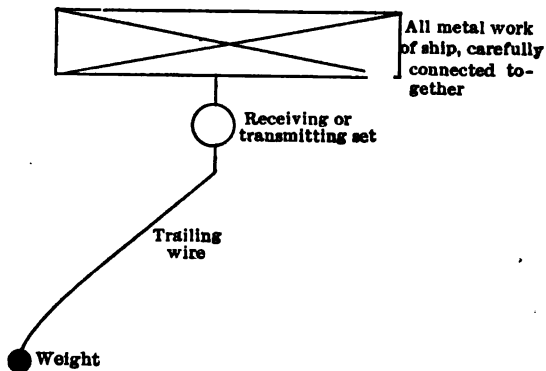

FIG. 34.—Arrangement of apparatus on aeroplane antennæ.

parts of the craft which, as already stated, form the counterpoise; this is schematically shown in Fig. 34; when the aircraft approaches ground the aerial wire is reeled in, the reeling-in apparatus being operated either by hand or by a small electric motor.

Such an arrangement as the one above described has been used with success on practically all types of aircraft, including lighter than air ships. Its only disadvantage seems to lie in the fact that in the case of a forced landing, and, more especially, in the case of an aeroplane being compelled to dive or to "loop-the-loop" the presence of the trailing antenna wire might prove disastrous unless it were reeled in very quickly.

Again, it may be easily understood that such an arrangement cannot be used unless the aeroplane is in flight.

It is reported that transmitting ranges up to 600 nautical miles have been obtained with trailing antenna wires on the large U. S. Navy N. C. flying boats of the type which crossed the Atlantic; although one must judge from the results of that test that operation over even one-tenth of this distance is problematical; signals may be received by means of such antennæ at almost any distance from high-power transmitting stations.

The second class of aircraft aerials comprises various types which enable signals to be sent out or received even while the craft is on the ground. The following types have been used:

- (a) Skid-fin aerials for aeroplanes.
- (b) Coil aerials for aeroplanes.
- (c) T-antenna for airships.

(a) The skid-fin antenna is nothing more than an inverted "L-antenna" the top of which is mounted a few feet above the uppermost

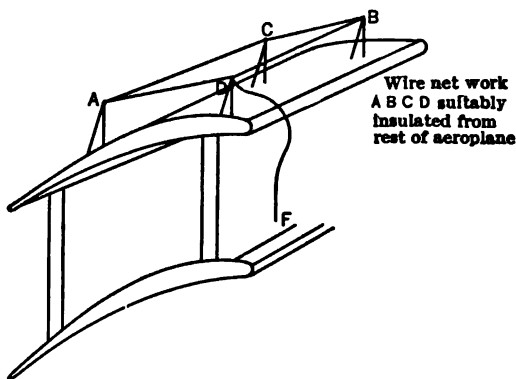

FIG. 35.—Aeroplane antenna of the skid-fin type.

plane and covers in length and width practically the entire wing, somewhat as shown by *ABCD* in Fig 35, where the wire *DE* is the leading-in wire and connects directly to the transmitter or receiver; the counter-poise consists as usual of all the metal parts electrically connected together. Such an antenna has been extensively used by U. S. Navy aeroplanes. It must

be understood that because neither the length of the leading-in wire nor that of the top wires can be made very large, and also because of the small separation between the antenna proper and the counterpoise the aerial is not a very good radiator, and, in general, aircraft carrying a skid-fin antenna also carry a trailing wire antenna. It may be said, in a general way, that the transmitting range of a skid-fin antenna is about one-half that of a dangling wire antenna for the same aircraft and transmitting apparatus.

When the metal work of a ship is used for counterpoise it must be

all very carefully bonded together, otherwise sparks may occur, when transmitting, which are, of course, an unnecessary fire risk.

(b) Coil aeriæls have been used more especially for receiving purposes, in view of their ability to detect the direction from which the waves may be coming. They are made up of several turns and of such dimensions as will enable them to fit in between the two wings of a biplane, somewhat as shown diagrammatically by *B*, Fig. 36. In this case no counterpoise is necessary. When the coil is used as a transmitter the greatest radiated field will be in the plane of the coil, similarly if the coil is used for receiving it will respond most vigorously to signals coming from the direction of *A* or *C*. In order to either send or receive in certain directions the coil may be rotated or else the aeroplane itself may be veered around until the plane of the coil points in the desired direction. In order to avoid either one or the other of these operations another coil may be used with its plane at right angles to the first, in which case the

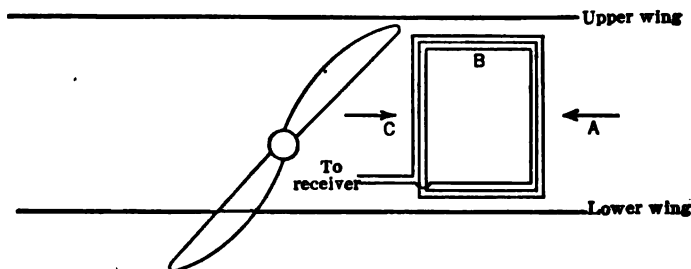

FIG. 36.—Coil type antenna installed between the wings of an aeroplane: the coil sides are placed behind the struts between the wings.

operator need do no more than move small coils within his easy reach; this will be more fully explained later, in the section on direction finders, p. 766.

The range of transmission of coil antennæ is small, but they are used for receiving from very great distances. Some aeroplanes carry a trailing wire for long-distance transmission while in flight, a skid-fin antenna while stationary, and a coil aerial for directional reception.

(c) The T-aerial for airships is schematically illustrated in Fig. 37, where *AB* is the leading-in wire and *CD* the top of the "T." The counterpoise consists of the metal parts of the suspended car, including engine, etc. Such an antenna has practically the same transmitting characteristics as a "T" antenna of the same dimensions used on the ground; and because the wire *AB* is quite long and the wires *CD* may be made very long as well, the range of the antenna is comparatively large. It need hardly be stated that the construction of such an aerial is such as to permit it to be used with equal effectiveness whether the air-

ship is in flight or not, and is a great improvement over the trailing wire antenna at first used on such ships. Care must, of course, be observed regarding the fire risk of the installation.

Underwater Antennæ.—The problem of underwater antenna is especially important in connection with submarines. Up to a few years ago communication by radio with a submarine, while submerged, was considered very unsatisfactory, because use was being made of antenna similar to ground antennæ such as the "T" type or inverted "L." These antennæ, even if made of heavily insulated wire, are more or less likely to be short-circuited by the water (particularly salt water) more especially because, as will be made fully discussed on p. 752, the highest potential is, when transmitting with such antennæ, present at the very end of the wires, where it is most difficult to guard against the short-

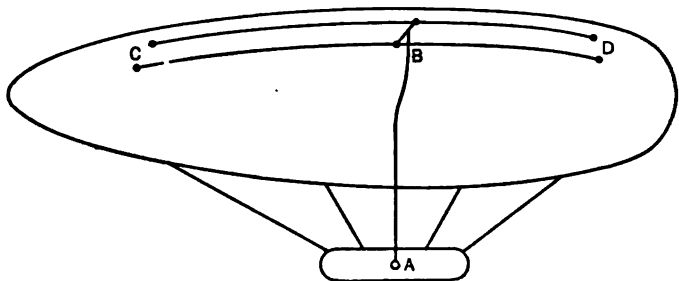

FIG. 37.—In a dirigible balloon a T type antenna is used, the counterpoise consisting of all the metal work around the engines, etc.

circuiting effect of the water. Aside from these considerations which are not, however, so very serious when using the antenna for receiving purposes, the more serious handicap was the fact that such an antenna projects too far above the topmost part of a submarine, even above the periscope and made it necessary for the submarine to submerge more deeply than would otherwise have been the case or else to use a short ineffective antenna.

Real progress was made in submarine radio transmission by the introduction of the loop antenna; in the application to submarine work the loop is made up somewhat as shown in Fig. 38. The wires *ABCD* and *QNML* are grounded at *A* and *Q*, and insulated from the boat everywhere else. Thus the loop may be diagrammatically represented as in Fig. 39 which should be compared with the diagram of the simple loop discussed on p. 708, and reproduced in Fig. 40 for the sake of convenience.

In the simple loop the wires *FG* and *F'G'* radiate most effectively when the distance between them is one-half a wave-length and the strongest field is produced by the loop in its own plane. Similarly in the case of

the submarine loop the wires AB and $A'B'$ are the radiators while CD and $C'D'$ radiate very little energy since they are very close together and the fields created by them practically neutralize each other; of course

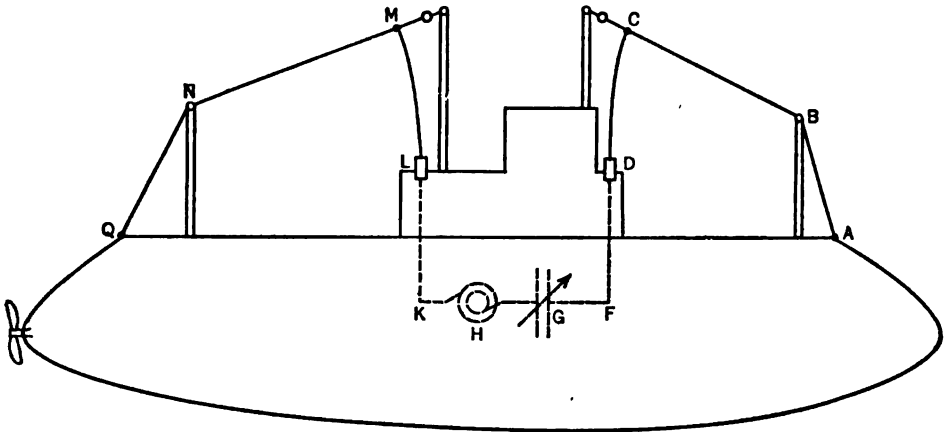

FIG. 38.—Arrangement of loop antenna in a submarine.

the best distance between AB and $A'B'$ is one-half a wave-length, and, again, as in the simple loop, the submarine loop will radiate best in its own plane.

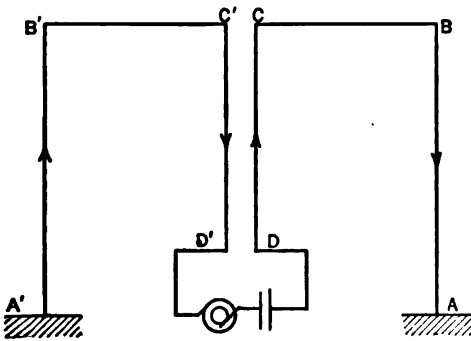

FIG. 39.

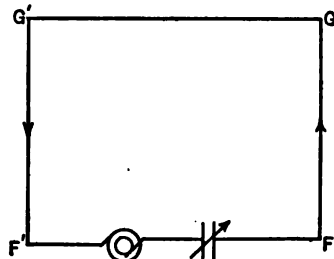

FIG. 40.

FIG. 39.—Electrical circuit of the installation of Fig. 38.

FIG. 40.—As wires CD and $C'D'$ of Fig. 39 radiate no appreciable power this arrangement is equivalent to the single turn coil here shown in wires AB corresponding to FG and $A'B'$ to $F'G'$.

Another arrangement used for submarines is a coil antenna consisting of a large number of turns and enclosed in a water-tight container which is supported above the deck of the submarine. The dimensions of such a coil are necessarily small (perhaps one meter square), and its effective-

ness as a transmitter is consequently low, but it has been used to receive from very great distances with considerable success.

A word should here be said regarding the transmission of electromagnetic waves in water. It was already pointed out in Chapter I that electromagnetic waves may be transmitted through any medium to more or less extent depending more especially upon the electrical conductivity of the medium. An electromagnetic wave will on striking a wall of ordinary conducting material be partly reflected and partly absorbed in the production of currents in the material, so that practically no electromagnetic field would be found at even a small depth below the surface of the material. On the other hand if the material is, as in the case of salt water, only a partial conductor the electromagnetic waves are able to penetrate into it for considerable distance before the energy represented by them is completely absorbed by currents produced in the water. It is a well-known fact that the greater the frequency (the smaller the wave-length) of a magnetic or electric field the smaller is the depth to which it will penetrate into a conducting or semi-conducting medium: therefore in the case of electromagnetic waves in water the extent to which they penetrate below the surface is very much dependent upon the wave-length.

The equation for penetration of an electromagnetic wave into a conducting medium was given on p. 115. Although there given as the penetration of a *current* the same formula holds if written to express either electric or magnetic fields. Thus we may write

$$H_x = H_0 \epsilon^{-\left(\sqrt{\frac{2\pi\omega\mu}{\rho}}\right)z}, \dots \dots \dots (15)$$

in which

H_0 = intensity of magnetic field, of the electromagnetic wave, just at the surface of the ocean;

H_x = intensity of magnetic field x cm. below surface;

$\omega = 2\pi \times$ frequency;

μ = permeability of sea water = unity;

ρ = resistivity of sea water in abohm sper cm.³ = approximately 10^{11} .

If we assume a signal detectable if H_x is only 1 per cent of H_0 , then the depth at which the signal should be detectable is obtained from

$$\epsilon^{-2\pi\left(\sqrt{\frac{\rho}{\omega\mu}}\right)z} = .01.$$

For a wave-length of 10,000 meters the value of x calculated from this relation is about 1500 cm. or 15 meters.

As an example of the effect of wave-length it has been stated that signals have been received by submarines with loop antennae with the

top of the loop 16 feet below the surface of the water at a wave-length of 6000 meters and 200 miles from the transmitting station, while for a wave-length of 2500 meters and the same distance signals could only be heard with the top of the loop 8 feet below the surface of water.

If we assume that the loop was such that the "mean depth" was 5 feet lower than the top of the loop, so that in one case the effective depth was 21 feet in the first case and 13 feet in the other the experimental results agree very well with those predicted from Eq. (15). Thus we have

$$\sqrt{\frac{6000}{2500}} \times \frac{13}{21} = .96.$$

Again, in case the submarine is transmitting while submerged, the transmitting range is very small because the electromagnetic waves are practically entirely absorbed in their passage through the water and issue therefrom with very feeble strength. Thus, it has been found that a submarine when submerged so that its loop antenna was only a few inches below the surface could only transmit to a distance of about 9 miles with a wave-length of about 1000 feet and an antenna current of 6 amperes; while it could transmit 50 miles or more when on the surface. Probably better transmission through the water would be expected if the wave-length were much larger (10,000 or more meters); but a large wave-length implies an antenna of dimensions too large to be carried by a submarine.

It is to be remembered that the question of *reflection* at the surface of the water is to be considered when analyzing communication possibilities from a surface station to a submerged boat or vice versa; this has not been attempted here.

It may generally be stated that the present state of the art does not permit a submerged submarine to transmit to any greater distances than about 10 to 20 miles, while, on the other hand, enabling it to receive from almost any distance provided it is not too deeply submerged.

Ground Antennæ.—This is the name given to an antenna consisting of an insulated wire laid on the ground but insulated therefrom as shown

by Fig. 41. In the figure the transmitter or receiver is shown connected to the middle of the wire, but it may be connected at either

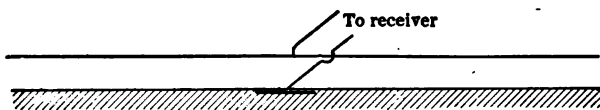

FIG. 41.—Use of a wire laid on the ground (but insulated from it) for an antenna.

end. In the former case such an arrangement will resemble a "T" antenna and in the latter an inverted "L" with a very short "lead-in" wire. Since it is the height of the lead-in wire which determines the

intensity of the field radiated it is plain that an antenna of this type is a very poor radiator. It has, however, been used as a receiver very successfully¹ in connection with vacuum-tube detecting devices.

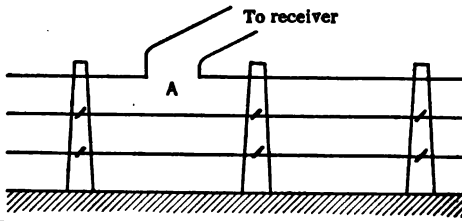

FIG. 42.—Even a fence wire serves as a fairly good antenna; it is opened and the receiving apparatus put in the break.

Again, a living tree has been used as an antenna for receiving. The receiver is, in this case, shown connected as in Fig. 43, where *A* is a nail driven into the trunk of the tree as high up as possible. It seems as if here, the actual receiving of the waves was mostly effected by the leading-in wire *AB*, while the uppermost parts of the tree serve to increase the capacity of the antenna and also to intercept, to a certain extent, electromagnetic waves which induce currents in the electrically conducting juices of the trees well as in the leading-in wire.

In general it may be stated that almost any system of electrical conductors more or less removed from ground and insulated therefrom is capable of absorbing energy from an electromagnetic wave passing by it and, when used in connection with the modern highly sensitive vacuum-tube detectors, may be easily made to detect the presence of waves.

Law of Radiation of Power from an Antenna.²—Upon consulting the literature there will be found many formulæ which are supposed to give

¹ See articles by A. H. Taylor, I. R. E., Vol. 7, Nos. 4 and 6.

² For a thorough mathematical discussion, see Pierce, "Electric Oscillations and Electric Waves."

As a matter of fact, as far as receiving is concerned, use has been made of a wire on a wire fence, in which case one of the wires has been opened at a point such as *A* (Fig. 42) and the receiver inserted therein.

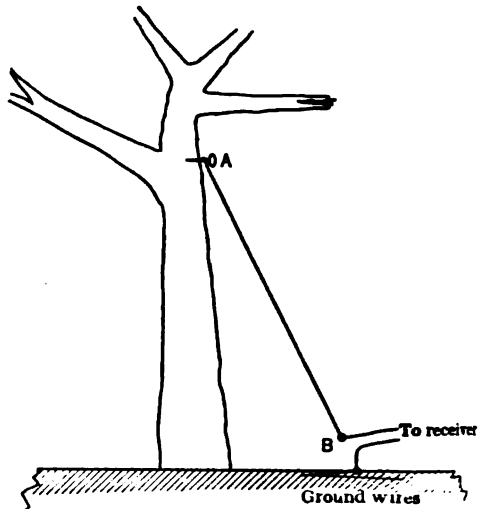

FIG. 43.—A tree has been recommended for an antenna; experiments seem to show, however, that the tree is practically nothing but a support for the upper end of the wire, the real receiving being done by wire *A-B*.

the power radiated from an antenna, in terms of the height, wave-length, etc., but in general they do not agree, and it is difficult to appreciate the derivation of some of them. The derivation given below yields a result different from those given by accepted authorities, but it undoubtedly represents the true state of affairs as well as any of them.

Practically all analyses start from the theory of the Hertzian doublet, supposedly modifying it properly to make it apply to the grounded antenna. In some derivations the amplitude of the current in the antenna is supposed constant (i.e., the effective value of the current the same at the top of the antenna as at the grounded end), and in others the amplitude is supposed to vary in some prescribed manner. Some formulæ use as the height of the antenna the actual height and others use a certain "effective height," measured to the "center of gravity" of the capacity of the antenna.

We shall consider the energy per cu. cm. at a point P (Fig. 44), in the equatorial plane of the oscillator and distant from it several wave-lengths,

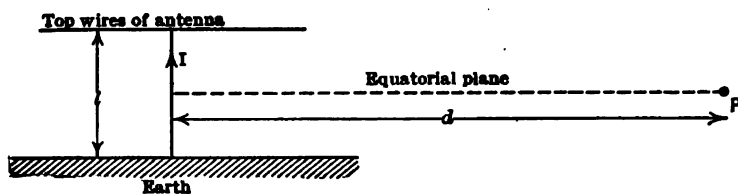

FIG. 44.—The energy radiated from an antenna is to be calculated from the law given the strength of magnetic field at P , in terms of the antenna constants.

so far that the induction field is negligible. Our first assumption is that the effective value of the amplitude of the current in the vertical part of the antenna is at all points the same; this is nearly true for the ordinary antenna, in which the capacity of the vertical wire is small compared to the capacity of the network of wires generally used for the top of the antenna. This assumption will give us a radiation somewhat greater than the true value. The next assumption we make is that the actual height of the antenna, l , represents the distance between the positive and negative charges of the antenna, the flow of which causes the antenna current I . In case of a ship antenna the height l is from the water to the top of the antenna. In case of a land antenna, with possibly a poor ground, it is likely that the average distance between the charges of the antenna is greater than the distance from the top of the antenna to the ground, so that it might seem that in this case we should take a distance greater than the actual height, if the theory of the doublet is to be applicable.

This is indicated in Fig. 45; it may be, for such a ground condition that the distance l' (average distance between charges) is considerably

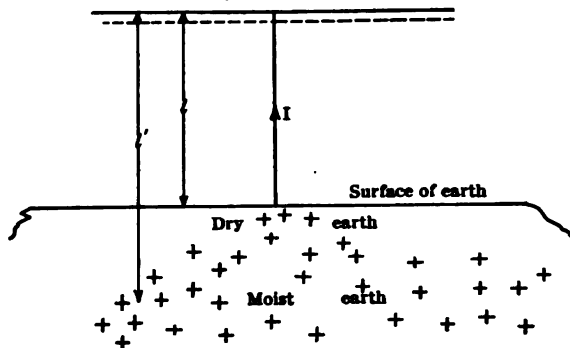

FIG. 45.—In an actual antenna there is undoubtedly a vertical motion of the charges in the earth under the antenna; this subterranean current will contribute practically no radiation at distant points because of absorption in the earth's surface.

greater than l . We shall neglect this extra height ($l' - l$), however, as it is not only indeterminable, but it contributes but little to the radiation reaching the distant point P ; the electromagnetic energy sent off from this subterranean part of the antenna could only reach P by traveling through the earth's crust, in which case the attenuation is so rapid that

the amount of energy arriving at P by this path will be negligible compared to that reaching P from that part of the antenna specified by the height l .

We shall therefore assume that Eq. (9) represents accurately the radiation field at point P , the symbols having the definite meaning given below.

$$H_m = \frac{2\pi l I_m}{10\lambda d},$$

in which H_m = maximum value of magnetic field at P , in gilberts per cm.;

l = actual height of antenna, in cm., from ground to top for flat-topped antenna;

I_m = maximum value of current (in amperes) in antenna this value being assumed the same throughout the height of the antenna;

λ = wave-length radiated, in cm.;

d = distance from antenna to point P , in cm.

Now the energy per cu. cm. at P , due to this magnetic field, is equal to $H_m^2/8\pi$, and as the electric field set up at P by this moving magnetic field must be of such magnitude that it represents the same energy per cu. cm. as that possessed by the magnetic field, the total energy per cu. cm. (maximum value) must be $H_m^2/4\pi$. As the electromagnetic wave travels past point P with the velocity of light, the electric and magnetic fields at this point both go through sinusoidal variations, so that the

average value of the energy per cu. cm., in terms of the maximum value of magnetic intensity, must be equal to one-half of the maximum energy, or $H_m^2/8\pi$.

If we now consider the effective value of the magnetic field at the point P , we have (as $H_m^2 = 2H^2$, H being the effective value) the average energy of the radiation field at P equal to $H^2/4\pi$, the energy being in ergs per cu. cm.

This energy of radiation travels past point P with the velocity of light, V , so that the energy streaming past P per sq. cm. (plane of the sq. cm. being perpendicular to distance d) per second is equal to $H^2V/4\pi$. Using now Eq. (9) to express H and substituting I (effective current) for I_m , we get

$$\text{Energy, in ergs, per sq. cm. per sec.} = 2 \left(\frac{2\pi I}{10\lambda d} \right)^2 \frac{V}{4\pi} = \frac{2\pi I^2 l V}{10^2 \lambda^2 d^2} \quad (16)$$

In calculating the total radiation from the antenna we must assume some law of variation in the value of H , as the point P is moved over the surface of a sphere of radius, d . In the ideal case the distribution of H over the surface follows a sine law as indicated in Fig. 46; it has a maximum value in the equatorial plane of the oscillator and zero directly above or below the antenna.¹ As the power per sq. cm. varies with the second power of H , and as H has a sinusoidal variation with respect to θ , Fig. 46, it is evident that the average power per sq. cm. over the whole imaginary sphere is

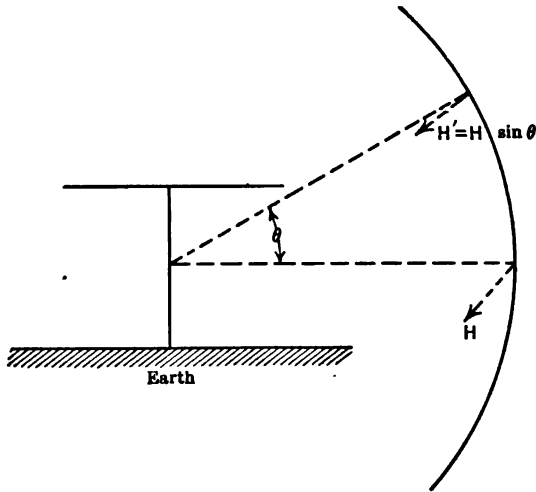

FIG. 46.—In calculating the total energy sent off from an antenna we assume a sinusoidal distribution of H , in the meridian plane.

$\pi/6$ times as great as at the equatorial plane, or putting $\pi/6 = \frac{1}{2}$ we have

$$\text{Average power per square centimeter} = \left(\frac{\pi I^2 l^2 V}{10^2 \lambda^2 d^2} \right).$$

¹This statement neglects the radiation from the horizontal currents in the upper wires of the antenna and in the earth. The amount of this radiation may be considerable and should be calculated in getting the total radiation from the antenna. As the problem lends itself at best to approximate treatment only, due to earth conditions, etc., it is not thought worth while to include the calculation of this up-and-down radiation.

The area of the sphere is $4\pi d^2$ so we have, for the total radiation from the oscillator

Total radiation, in ergs per second

$$\begin{aligned} &= \left(\frac{\pi I^2 l^2 V}{10^2 \lambda^2 d^2} \right) 4\pi d^2 \\ &= \frac{4\pi^2 I^2 l^2 V}{10^2 \lambda^2}. \end{aligned}$$

Or we have, watts

$$= 120\pi^2 \frac{I^2 l^2}{\lambda^2} \dots \dots \dots (17)$$

In this formula I is measured in amperes (effective) and l and λ are measured in any convenient unit, providing it is the same for both.

It will be noticed that in this derivation the treatment does not agree with that ordinarily given¹ in that the radiation is considered as occurring

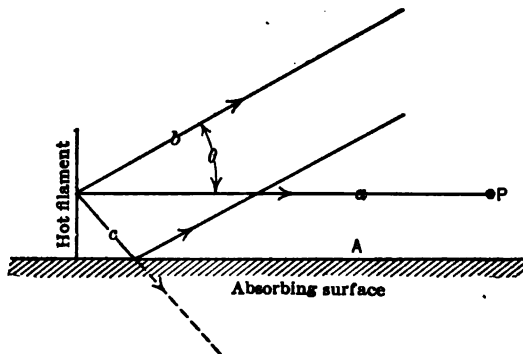

FIG. 47.—The radiation of light from an incandescent filament standing in a partially reflecting surface is exactly analogous to the radiation of radio waves from an antenna.

over a *whole sphere* instead of only a hemisphere. It will be appreciated that this way of looking at the question is correct if any analogous problem in radiation is considered. Thus imagine an upright incandescent filament sending out light as indicated in Fig. 47. The filament is supposed to have its lower end resting on a surface which absorbs part of the incident light and reflects the rest.

Let us suppose that, by use of accepted formulæ, we have obtained the intensity of illumination at P , due to light traveling from the filament directly to P . (This excludes light arriving at P after being reflected from surface A .) Suppose further that we know the law for the distribution of radiation, with respect to the angle, θ , this law representing the distribution in a homogeneous medium, i.e., exclusive of any such reflecting surface as we have at A . From this law we can obtain the average lumens per sq. cm. which would exist over the surface of a sphere through P if the reflecting surface A were not present. To get the total radiation it is evident that we must multiply this average illumination

¹ See Berg, "Electrical Engineering," advanced course, p. 292.

by the whole surface of the supposed sphere if we are to get the total radiation from the filament. To be sure, the lower half of the sphere below the surface *A*) actually gets inappreciable illumination, due to reflection at the surface and to absorption in the material below *A*, but this fact in no way alters the radiation from the filament, it merely redistributes the lumens *after they have left the filament*, and increases to some extent the illumination in the upper hemisphere. The surface of the earth

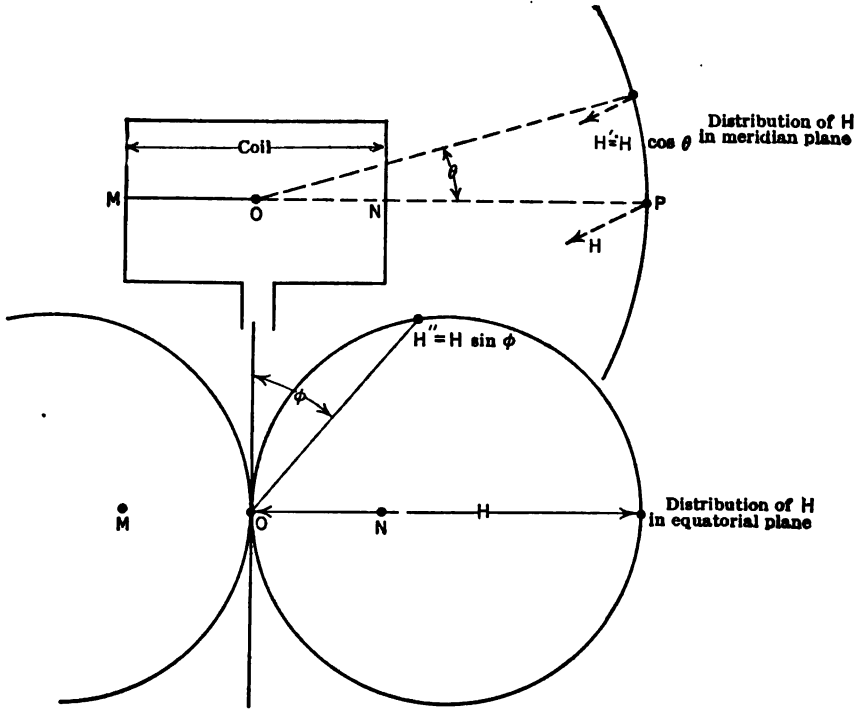

FIG. 48.—In calculating the power radiated from a coil we assume a sinusoidal distribution of *H* in both equatorial and meridian planes.

acts in the same way towards the radio waves as does the surface *A* to the light rays striking upon it.

In the case of a coil the formula for radiation may be at once obtained by using the proper value for *H* in the previous deduction for the ordinary antenna. We suppose a coil of one turn the length of whose vertical sides is *l*, and the width between these sides is *s*; the value of *H* in the equatorial plane is

$$\left(\frac{4\pi I l}{10\lambda d}\right) \sin \frac{\pi s}{\lambda}.$$

If the coil has *N* turns of course this value of *H* must be multiplied by *N*.

The formulation of the total radiation for the coil requires the knowledge of the distribution in the meridian plane as well as the equatorial plane. Assuming both these distributions sinusoidal,¹ as indicated in Fig. 48, we find the average value of H^2 and thus we get the total radiation from the coil

$$\text{Watts} = 240\pi^2 \frac{I^2 l^2}{\lambda^2} \sin^2 \frac{\pi s}{\lambda} \dots \dots \dots (15)$$

In the case the coil is so narrow that $\sin \frac{\pi s}{\lambda} = \frac{\pi s}{\lambda}$ we have

$$\text{Watts} = 240\pi^4 \frac{I^2 l^2 s^2}{\lambda^4}, \dots \dots \dots (19)$$

and if the coil is square so that $s = l$ we have

$$\text{Watts} = 240\pi^4 I^2 \left(\frac{l}{\lambda}\right)^4 \dots \dots \dots (20)$$

It was mentioned when calculating the radiation from an ordinary antenna that the horizontal parts of the antenna give off considerable radiation, which was neglected in getting the total radiation. It must be noticed that in the case of the coil antenna this omission causes a very large error, because by its very form, the coil radiates as much from its horizontal sides as it does from its vertical sides, if the coil is a square. In case the coil is not square its radiation due to the horizontal sides may be obtained at once by interchanging the symbols s and l in Eq. (14). Taking this extra radiation into account it would seem that the total power radiated from a square coil is twice the value given by Eq. (20).

All of the foregoing formulæ for radiation have been obtained on the assumption that the current was uniform in amplitude throughout the length of the radiating portion of the antenna. If it is evident that when such is not the case (as, for example, a straight vertical grounded wire) the average value of the current must be approximated and this value used in the proper formula. Thus, for the single wire just referred to, if considerable loading is used, the average current is one-half the value of current at the ground end of the antenna and the radiated power would be one-quarter of the value given by Eq. (17). If, on the other hand, the wire was oscillating at its fundamental ($l = \lambda/4$) the average current would be $2/\pi$ of the current at the base and the power would be $(2/\pi)^2$ or 41 per cent of the value given by Eq. (17).

Both Eqs. (17) and (18) show that the power radiated by either a coil or a simple antenna is a direct function of the square of the height

¹As noted before, the treatment of radiation given here is elementary and approximate only; the student is referred to Chapter IX of Pierce's "Electric Oscillations and Electric Waves" for a full treatment of the subject.

and the square of the current, and an inverse function of the square of the wave-length.

We will illustrate the influence of the wave-length upon the power radiated by means of an example. Assume a simple antenna for which

$$l = 10,000 \text{ cms.} = 100 \text{ meters}$$

$$I = 20 \text{ amperes}$$

then if

$$\lambda = 1000 \text{ meters } (f = 300,000 \text{ cycles per sec.})$$

$$\text{Power} = 120\pi^2 \times \frac{100^2 \times 20^2}{1000^2} \cong 4800 \text{ watts,}$$

while, if

$$\lambda = 100,000 \text{ meters } (f = 3000 \text{ cycles per sec.})$$

$$\text{Power} = 120\pi^2 \times \frac{100^2 \times 20^2}{10^{10}} \cong \frac{24}{10^2} = 0.48 \text{ watt}$$

Thus it may be seen that it is impossible to radiate power to any great extent at low frequencies and it must also be remembered that this hypothetical case of 20 amperes supplied to an antenna at 3000 cycles is impossible of realization.

Radiation Resistance.—Radiation resistance is a fictitious resistance the value of which is such as will absorb the same power as is radiated for the same current as flows in the antenna.

From the definition the radiation resistance may be found by dividing the power radiated by the square of the antenna current. Thus, from Eqs. (17) and (19) we find

Radiation Resistance for simple antenna

$$= 120\pi^2 \frac{l^2}{\lambda^2} \dots \dots \dots (21)$$

Radiation Resistance for single turn coil having a width equal to s , small compared to one-half a wave-length

$$= 240\pi^4 \frac{l^2 s^2}{\lambda^4} \dots \dots \dots (22)$$

The radiation resistance is used as a measure of the ability of an antenna to radiate power. An antenna with a high radiation resistance is a good radiator, and vice versa.

As previously pointed out the values of resistance obtained from Eqs. (17) and (19) may be far from correct for an actual antenna.¹ A single

¹The fact that a few experimental results give values of resistance equal to that calculated from certain formulæ does not substantiate the formulæ by any means; the conditions obtaining in the experimental work are far different from those assumed in the theory.

vertical wire (no top wires) will have a resistance only 41 per cent of the value given by Eq. (17) when oscillating at its natural period and if much loading is used, so that the amplitude of current decreases uniformly from base to top of antenna the radiation resistance will be but 25 per cent of the value calculated from Eq. (17).

In the case of the coil antenna, radiating up and down, as well as horizontally, the radiation resistance is probably much greater than the value given by Eq. (18), for a square coil perhaps twice as much.

Current in Receiving Antenna.—It is important to be able to calculate the current in the receiving antenna, because the value of this current determines whether or not it is possible to hear the signals which cause such a current to flow in the receiving antenna. It must be here stated that were it not for the interference of the so-called "strays" (see p. 193) it would be possible, due to the extreme refinement and sensitiveness of modern detecting apparatus, to hear signals, no matter how

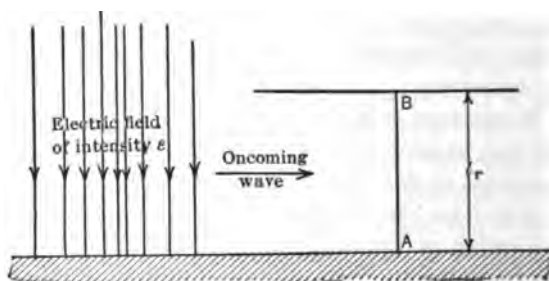

FIG. 49.—Wave with electric gradient, ξ , approaching a receiving antenna.

small the currents in the receiving antenna. In view of the "strays" however, which also produce currents in the receiving antenna, the signal currents must be larger than would otherwise be necessary, so that the "strays" may interfere with the signals as little as possible; since the "strays" currents have considerable magnitude it follows that attention must be paid to making the signal currents large. Hence the importance of knowing the factors affecting the signal current in the receiving antenna. We will determine this for a simple antenna and for a coil antenna.

Received Current in Simple Antenna.¹—Consider the antenna represented by Fig. 49 in the path of electromagnetic waves moving, as

¹ In an article by Bennett, in the Journal of the A. I. E. E., for Nov. and Dec., 1920, various properties of antennæ are analyzed and exact expressions for them derived. Among other things, he shows that an antenna having negligible resistance (other than radiation), the amount of power which can be abstracted by a receiving antenna is equal to about 6% of the amount flowing through an area (parallel to the wave front equal to $(\lambda)^2$ square meters, λ being in meters.

shown in a direction perpendicular to the antenna lead-in wire $A-B$. The electric field will act in a direction parallel to AB , hence there will exist a difference of potential across AB which will be equal to its length multiplied by the intensity of the electric field. Thus, if:

- ξ = effective value of intensity of electric field at AB , in volts per cm.;
- l_r = height of receiving antenna, in centimeters;
- I_r = effective value of current in receiving antenna, in amperes;
- R = effective resistance of the antenna, this of course depending among other things upon the coupling and adjustments in the closed receiving circuit, type of detector used, etc.

Then, since the receiving circuit is always adjusted to resonate to the frequency of the incoming waves, it follows that the reactance will be zero and current in this circuit will be given by:¹

$$I_r = \frac{\xi l_r}{R} \dots \dots \dots (23)$$

It now becomes necessary to substitute for ξ its value in terms of the transmitting antenna constants.

From Eqs. (10) and (15) we have:

$$\xi = \frac{60\pi I}{\lambda d},$$

volts per cm. for a simple antenna;

$$\xi = \frac{120\pi N I I}{\lambda d} \sin \frac{\pi s}{\lambda},$$

for a coil of N turns and width s .

Substituting in Eq. (23), we have:

$$I_r = \frac{60\pi l_r I}{\lambda d R} \dots \dots \dots (24)$$

for a simple transmitting antenna;

$$I_r = \frac{120\pi N l_r I}{\lambda d R} \sin \frac{\pi s}{\lambda} \dots \dots \dots (25)$$

for a coil transmitter of N turns and a width s with the receiving antenna in the plane of the coil.

¹ These solutions hold only for the steady state; they are not good until the transient condition is past.

Received Current in a Coil Antenna.—Assume the single turn coil of Fig. 50 placed in the path of incoming electromagnetic waves, the wave front and plane of the coil being perpendicular to each other and the electric field of the wave being parallel to conductors AB and $A'B'$.

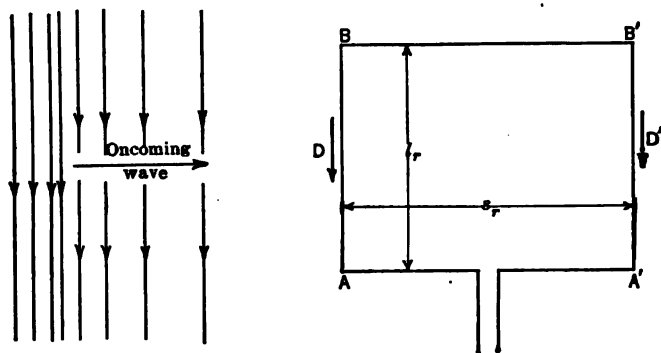

FIG. 50.—Wave approaching a coil antenna.

Then, if D and D' represent the assumed positive direction of the potential difference established across AB and $A'B'$ and, if:

ξ = effective value of intensity of electric field at AB , in volts/cm.;

ξ_1 = effective value of intensity of electric field at $A'B'$, in volts/cm.;

s_r = width of coil in cms.,

we have:

ξ_r = effective value of potential difference across AB ;

ξ_{r1} = effective value of potential difference across $A'B'$,

$\frac{2\pi s_r}{\lambda}$ = phase difference between $l_r \xi$ and $l_r \xi_1$ in radians.

The total electromotive force within the entire coil is equal to the vector difference of $l_r \xi$ and $l_r \xi_1$. Since AB and $A'B'$ are at practically the same distance from the radiating antenna, the values of $l_r \xi$ and $l_r \xi_1$ will be the same, but their phases will differ. Hence, total electromotive force within the coil is obtained by taking the vector difference of the e.m.f.'s in the two sides of the coil, as shown in Fig 51.

We then have

$$2l_r \xi \sin \frac{\pi s_r}{\lambda} = \text{electromotive force in coil}$$

and effective value of current on the assumption of a tuned receiving circuit is given by:

$$I_r = \frac{2l\xi}{R} \sin \frac{\pi s_r}{\lambda} \dots \dots \dots (26)$$

for a single turn coil.

In case the receiving coil has N_r turns Eq. (26) becomes

$$I_r = \frac{2l\xi N_r}{R} \sin \frac{\pi s_r}{\lambda} \dots \dots \dots (27)$$

for a coil of N_r turns.

And substituting for ξ the expressions obtained from Eqs. (10) and (15) we finally have the following:

$$I_r = \frac{120\pi N_r l_r I}{\lambda d R} \sin \frac{\pi s_r}{\lambda} \dots \dots \dots (28)$$

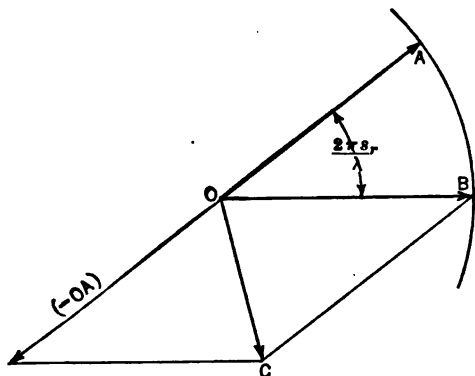

AO = e.m.f. induced in A-B = $l_r \xi$
 OB = " " " A'-B' = $l_r \xi_1$
 OC = vector difference of
 OB and OA = e.m.f.
 acting in the coil.
 $= 2 l_r \xi \sin \frac{\pi s_r}{\lambda}$

FIG. 51.—The effective induced e.m.f. of a receiving coil antenna is obtained by subtracting vectorially the e.m.f.'s. induced in the two sides.

for current received in a coil antenna from a simple transmitting antenna lying in the plane of the receiving coil;

$$I_r = \frac{240\pi N_r l_r I}{\lambda d R} \sin \frac{\pi s}{\lambda} \cdot \sin \frac{\pi s_r}{\lambda} \dots \dots (29)$$

for a transmitter coil of width s and placed with its plane in that of the receiving coil.

For the sake of convenience all receiving formulas are collected below; it is assumed that: the vertical wires of the receiving antenna are parallel to the electric field of the oncoming wave, that the transmitting antenna current is undamped and of uniform amplitude throughout, that there is no energy absorption by the medium, that the receiving circuits are tuned to the transmitting frequency, and that the planes of the coils

(either transmitters or receivers) are directed towards the other antenna or coil.

Antenna to antenna

$$I_r = \frac{188\mu_r I}{\lambda d R} \dots \dots \dots (30)$$

Coil to antenna

$$I_r = \frac{376N\mu_r I}{\lambda d R} \sin \frac{\pi s}{\lambda} \dots \dots \dots (31)$$

Antenna to coil

$$I_r = \frac{376N\mu_r I}{\lambda d R} \sin \frac{\pi s_r}{\lambda} \dots \dots \dots (32)$$

Coil to coil

$$I_r = \frac{752NN\mu_r I}{\lambda d R} \sin \frac{\pi s_r}{\lambda} \sin \frac{\pi s}{\lambda} \dots \dots \dots (33)$$

In case the angle $\frac{\pi s}{\lambda}$ is sufficiently small that the angle may be substituted for its sine these formulæ become somewhat simpler in form. We have

Coil to antenna or antenna to coil

$$I_r = \frac{1180N\mu_r s I}{\lambda^2 d R} \dots \dots \dots (34)$$

Coil to coil

$$I_r = \frac{7450NN\mu_r s s_r I}{\lambda^3 d R} \dots \dots \dots (35)$$

In every one of the preceding formulæ it is to be noted that the received current is:

A direct function of receiving and transmitting antenna heights and the transmitting antenna current.

An inverse function of the wave-length, to the first, second, or third power the distance and the resistance of the receiving antenna circuit.

Returning to the matter of the effect of "strays" it is apparent that if the received signal current is made large by suitably arranging the receiving antenna constants, then the "strays" current will at the same time be made large, and thus reception may be poor. On the other hand if the receiving antenna constants are poor and the transmitting antenna constants very good, then the received signal current will be large while the "strays" current will be small, with consequent improvement in

¹ It is to be pointed out that whereas the constants in these formulæ are given to the third significant figure, the actual received current may differ from the predicted value greatly; refraction and reflection of the waves play an important role in transmission.

reception. This explains the modern tendency towards radiating systems of very large dimensions and receiving systems of small dimensions.

In using a coil antenna for reception of signals, a regenerative, or "feed-back" connection of some sort should be used, to reduce the resistance of the coil as much as possible. Such a scheme involves a connection similar to the connection of the closed circuit of Fig. 127, p. 514, where it must be supposed that the coil L_2 of the diagram represents the coil antenna used for receiving.

The reception Equations (30) to (35) should be modified by multiplying by suitable factors when the transmitting antenna current is damped, when there is absorption of energy by the medium and when the plane of the coil is not parallel to the direction in which the waves are being propagated. The factors are as follows:

When the transmitting antenna current is damped ¹

$$\text{Factor is } \sqrt{\frac{\delta}{\delta + \delta'}}$$

When there is absorption ²

$$\text{Factor is } \epsilon^{-0.000047 \frac{d}{\sqrt{\lambda}}}$$

When the plane of coil is not parallel to the direction in which the waves are being propagated

$$\text{Factor is } \cos \alpha,$$

where δ = decrement of receiving antenna circuit;
 δ' = decrement of transmitting current;
 d = distance between station in meters;
 λ = wave-length in meters;
 α = angle made by plane of coil with the direction of propagation of the waves;
 ϵ = base of natural logarithms.

Comparative Merits of Different Types of Antennæ.—At the transmitting station it will probably always be necessary to use a high antenna, directive or not as desired, but for receiving a signal it is scarcely ever advantageous to use the same high antenna as used for transmitting.

The readability of a signal depends not upon the actual strength of the signal, but upon the ratio of signal strength to that of the disturbing noises also present. As static interference comes from all directions

¹ See Dellinger's paper on "Radio Transmission," Proc. A. I. E. E., Oct., 1919.

² See Scientific Paper No. 226 of the Bureau of Standards. This absorption coefficient holds good only over the ocean, in daylight. Over land, and over either land or ocean at night time the transmission is too erratic to make a formula worth while.

the ratio of signal to static may evidently be increased by using a directional receiving antenna; also, as it seems probable that most of the energy of strays may be considered to exist in the form of highly damped, long-wave signals, the best antenna will be one that absorbs but little energy from waves greater than that for which it is tuned. A coil antenna satisfies both of these requirements better than the ordinary high antenna, it being directional and having induced in it a voltage inversely proportional to the wave-length, for an oncoming wave of fixed value of electric field, ξ ; the induced voltage in the ordinary antenna under the same conditions is independent of wave-length. (The statement regarding the coil antenna presupposes a coil width s , small compared to the wave-length, practically always the case.)

It is, of course, true that the intensity of signal received by the coil antenna will be only a small fraction of what it would be with the other antenna but *the static interference will be even a smaller fraction*. Hence by a good amplifier the signal may be brought up to readable intensity and (if the amplifier increases static and signal equally) the amplified weak signal from the coil will be more easily read than an equally loud, unamplified, signal from the high antenna.

The validity of the above argument depends to some extent upon the actual ratio of radiation resistances of the two antennas; if e.g. the coil has an induced signal current only 0.0001 as much as that of the high antenna, then it will be necessary to use an amplification of 10,000 times (in volts) to make the coil signal as loud as that from the other antenna. In the present state of the art it is likely that such an amplifier would generate in itself sufficient noises (due to microphonic resistances, "dirt" on hot filament, etc., see Chapter XI) to make the signal unreadable.

Limitation of Transmission Formula.—It is important at this point to make certain qualifications as to the expressions previously given regarding the intensity of the field at a distance from the antenna, the power radiated by a transmitting antenna, and the current received by a receiving antenna. Since the expressions for the power transmitted and for the current received are, in turn, directly based upon that for the intensity of the field at a distance from the radiating system we will discuss this latter expression first, and the results of the discussion will be applicable to the expressions for power transmitted and for current received. The intensity of the field radiated by an antenna as given on p. 706 is derived from the theory of a doublet, the application of this theory requiring for the actual grounded antenna the assumptions

- (a) That there is no absorption between the two stations;
- (b) That the effective value of the antenna current is the same throughout the entire antenna height;

- (c) That the receiving antenna is in the equatorial plane of the transmitting antenna;
- (d) Refraction and reflection effects are negligible.

None of these assumptions is fully warranted. Hence, since, in most cases, there is some absorption, and the current is not uniformly distributed, and the two stations are far from being on each other's equatorial plane it is evident that Formulæ (30)–(35) must be considered as rough approximations only, giving as close a solution of the problem, however, as is possible to obtain under the circumstances.

Experiments have been made to determine experimentally the value of the received current and the results check, roughly, the values calculated by means of the formulæ on p. 742;¹ keeping in mind the large number of uncertain factors entering in both the transmission and reception, and that in the present stage of the art it is not necessary to predetermine results any closer than even 50 per cent, it is safe to consider the accuracy of the formulæ for power transmitted, current received and field radiated within the limits of present-day practice.

Counterpoises.—It has already been stated that an antenna, other than a loop or coil aerial, must necessarily consist of a so-called aerial, which radiates, and a counterpoise, which may or may not radiate. In the simple Hertzian double the counterpoise radiates, and this is also true to a certain extent of the counterpoise used in aircraft, made up, as it is, of the metal parts of the craft. In most cases, however, the counterpoise is the ground itself.

Sometimes when the ground is dry and therefore a poor conductor the counterpoise consists of a network of wires laid on the ground (in some cases insulated from it) directly underneath the top of the antenna proper. In every case it must be understood that the purpose of the counterpoise is to enable charges of electricity to be transferred to and from between itself and the aerial with as little loss (due to heat development) as possible, and for this reason it must have low resistance and it must also have sufficient capacity. The metallic surface of the counterpoise should be at least equal to that of the antenna and is in most cases larger.

A counterpoise having a small surface has the same effect as a small capacity connected in series with the aerial; that is, it makes the antenna capacity very small. In order to make such a low capacity aerial resonate at desirable frequencies it will probably be necessary to use a large loading inductance, which is generally accompanied by a large resistance; hence the power lost and the decrement of such an aerial are very large. As a matter of fact it is generally attempted to make the counterpoise of as large a surface and as low a resistance as possible. As a rule, when the

¹ See note on p. 196, for later experimental evidence regarding transmission formula.

ground underneath the antenna is a good conductor (wet, soft earth) the ground itself is used as a counterpoise and connection is made with it by means of copper plates or network of wires sunk into the ground at various places within the area underneath the antenna. These buried conductors should be put deep enough so that the earth around them is permanently moist.

Antenna Resistance.—An antenna or coil transmitter absorbs power when supplied with high-frequency currents by an alternator or some other generator of such currents. Some of this power is, as has already been pointed out, radiated in the form of an electromagnetic field, and represents useful power, while the rest is consumed in various ways and represents a complete loss, in so far as it contributes nothing towards radiation.

In dealing with the power absorbed by a circuit such power is, for the sake of simplicity, looked upon as if it were expended in a resistance of such a value as would consume the actual power expended in the circuit for the same current as flows therein. This fictitious resistance is known as “effective resistance.”¹

Since the total power expended in an antenna is partly radiated and partly “lost” due to various causes we may divide the “effective resistance” of an antenna in two parts, i.e.:

- (a) Radiation resistance.
- (b) Loss resistance.

The radiation resistance has already been defined on p. 737, and the expressions therefor have been derived for a simple antenna and for a coil transmitter; these expressions are, for convenience, rewritten below:

$$R = 120\pi^2 \frac{l^2}{\lambda^2} \dots \dots \dots (19)$$

for simple antenna

$$R = 240\pi^4 \frac{l^2 s^2}{\lambda^4} \dots \dots \dots (20)$$

for single turn coil having a width s small compared to λ .

The loss resistance is due to a number of losses which are enumerated and discussed below:

- (1) Loss in poor dielectrics in the neighborhood of the aerial.
- (2) Loss in the resistance of the aerial.
- (3) Loss in the resistance of the counterpoise, generally the ground.
- (4) Loss due to eddy currents in neighboring conductors.
- (5) Loss due to leakage over insulators, etc.
- (6) Loss due to corona.

¹ See pp. 112 et seq.

(1) The loss in poor dielectrics is due to the hysteresis¹ phenomenon taking place in all dielectrics, and most especially in poor dielectrics such as wood, concrete, masonry, trees, etc., which may happen to be in the vicinity of the aerial and hence acted upon by the electrostatic field about the aerial. This loss resistance is analogous to that due to magnetic hysteresis in iron and is an inverse function of the frequency or a direct function of the wave-length as discussed on p. 169. The effective resistance due to dielectric loss must, therefore, increase as the wave-length increases or as the frequency diminishes. This loss is one of the most important² taking place in a radiating system and should be reduced to a minimum by keeping the field of the antenna free from unnecessary obstructions wherein a dielectric loss is likely to take place. As the highest electric gradient occurs near the end of an Γ or Υ antenna, especial care must be taken to keep poor dielectrics away from this part of the antenna.

In the case of a ship's antenna much loss may occur in the "lead-in" insulator where it enters the radio room; in case the radio room is wood, no metal (except the wire itself) should be used in this insulator. When the radio room is metal or where the "lead-in" wire has to go through metallic bulkheads, a considerable power loss occurs in the insulator.

(2) The loss in the ohmic resistance of the aerial wire should be kept low by making the wire of large cross-section and good conducting material. The large useful cross-section may be obtained by using a large number of very fine wires which are insulated from one another in order to prevent the skin effect increasing the resistance.³ The material is generally some bronze (phosphor or silicon bronze), since this combines fair conductivity with great tensile strength; mechanical considerations generally determine the kind of cable to use, in that many times a seven-strand cable is used which has practically as much skin effect as solid wire.

(3) The loss in the resistance of the counterpoise necessarily occurs because there are currents flowing therein which must produce a Joulean loss of power as they encounter a resistance. A counterpoise should be made of the smallest possible resistance. Where the ground is the counterpoise it is important that connection be made thereto by means of a large number of copper plates buried all around the antenna in soft, moist soil. It was already pointed out how the multiple tuned antenna may be employed in order to diminish as much as possible the ground resistance.

(4) Loss due to eddy currents in neighboring conductors may be diminished by eliminating as much as possible all metal masses from the neighborhood of the antenna. Of course this is quite impossible in so far as metallic masts are generally used to support the antenna, and, besides,

¹ See pp. 166 et seq.

² See Bureau of Standards Scientific paper No. 269, by J. M. Miller.

³ See pp. 122 et seq.

if these masts were replaced by wooden or concrete masts the latter might suffer considerable dielectric loss.

Since eddy currents and the loss due thereto increases with an increase of the frequency it follows that the effective resistance representing this loss increases with the frequency or decreases with an increase of the wave-length.

(5) The loss due to the leakage currents flowing between the aerial and the counterpoise should be kept down by using suitable insulators between the antenna wires and the supports and also between the lead-in wire and any walls through which it passes so that the resistance of the leakage paths may be made as high as possible. The resistance of the leakage paths is, of course, very much diminished in wet weather and, especially, where sprays from a rough sea reach the aerial. It has already been pointed out that in the case of submarines the ordinary antenna is very inefficient, except on a smooth sea, because of the salt-water sprays producing large leakage currents to ground and thus absorbing the largest part of the energy given to the antenna.

Since the loss due to leakage is a direct function of the (voltage)² and the latter is inversely proportional to the frequency (for a given current) it follows that the effective resistance corresponding to leakage loss varies inversely as the square of the frequency and directly as the square of the wave-length.

(6) The loss due to corona takes place at high voltages and is due to the partial ionization of the air about the antenna wires, which causes the air to become a partial conductor and carry a current. At night the corona effect is visible through the glow which accompanies it. The corona does not begin to take place except at a certain definite voltage, which, however, varies with the shape and size of the conductors; this critical voltage is smallest where the conductors are small and at points and corners. Once the critical voltage has passed, a large amount of energy loss may take place due to corona. As a matter of fact this phenomenon is to a certain extent a limitation upon the amount of power which may be radiated by an antenna in so far as, for an antenna of certain dimensions, the greater the power given thereto the greater must be the voltage and hence the greater the corona loss; thus, for a certain antenna there is a limit to the power input, beyond which it is inadvisable to go because a large amount of power is wasted due to corona loss, and little is gained as far as power radiated is concerned.

This limit is reached when the voltage at the ends of the antenna is in the neighborhood of 150,000 volts.¹ This is one reason why the use of very large radiating systems for large stations is imperative in order

¹ As mentioned before this limit depends upon how well the antenna conductors are kept free from sharp points and edges.

that the large capacity resulting therefrom may keep the voltage below the limit of corona loss even for large amounts of power input. The effective resistance representing this loss is for a fixed current an inverse function of the frequency and a direct function of the wave-length, for voltages above the critical value.

From the above we have, then, that for a certain antenna and for a fixed current therein:

Radiation resistance is an inverse function of $(\lambda)^2$;

Resistance corresponding to (2), (3) and (4) (eddy currents and skin effect) decreases as λ increases;

Resistance corresponding to (1), (5) and (6) (dielectric loss, leakage, corona) increase with increase in λ .

The above relations are roughly indicated in Fig. 52, where the various components of the antenna resistance have been plotted, together with

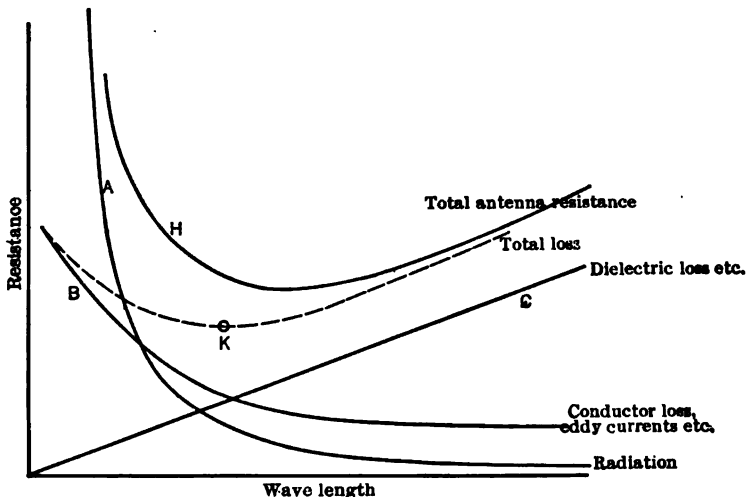

FIG. 52.—Various components of antenna resistance, showing approximately how they vary with wave-length.

curves showing the total loss resistance and the total antenna resistance. From the component curves *A*, *B*, and *C*, we have obtained the total loss resistance curve, by adding the ordinates of curves *B* and *C*, and, finally, the total antenna resistance, curve *H*, by adding the ordinates of the curves *A*, *B*, and *C*. The important point brought out by the curves is that, because some of the loss resistance components are a direct function, and others an inverse function, of the wave-length, it follows that the total loss resistance has a minimum value, as represented by the point *K* on curve *F*. It would seem, then, as if from the point of view

of the losses the best wave-length at which to use an antenna should be that corresponding to point *K*, and in practice this is approximately

the most efficient wave-length at which to operate an antenna.

The curves given above are purely of a theoretical nature, because the components of the antenna resistance cannot be satisfactorily measured by the methods at present available. However, total resistance curves of actual antennæ, which are easily obtained, are all found to have the shape of curve *H*, and the point of

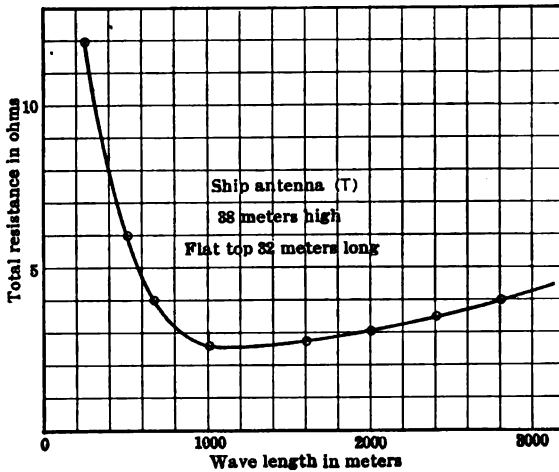

Fig. 53.—Total resistance curve for a ship's antenna.

minimum resistance is always found to be at wave-lengths considerably greater than the fundamental wave-length, perhaps twice as great.

Some typical resistance curves of actual antennæ are given herewith:

Fig. 53 shows the resistance for a ship's antenna for which the minimum resistance takes place at a wave-length of 3.5 times the fundamental. The ordinary land station antenna resistance resembles this curve in form, but generally the resistance increases with the longer wave-lengths more rapidly than does that given in Fig. 53. Fig. 54 gives the total

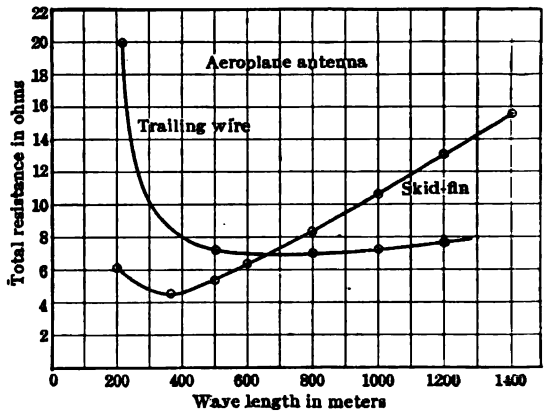

Fig. 54.—Resistance curves for two types of aeroplane antenna.

resistance for an aeroplane antenna of the trailing-wire type and one of the skid-fin type; both of these antennæ have about the same fundamental wave-length. It is to be noted that the trailing-wire antenna curve shows large resistance to the left of the minimum value,

while the other curve shows large resistance to the right of the minimum value. This is accounted for as follows: a trailing-wire antenna is a much better radiator than a skid-fin antenna, hence the radiation resistance should be larger in the former and therefore that part of the curve to the left of the minimum, which is very much affected by the radiation resistance, should have the larger ordinates in the trailing antenna than in the skid-fin antenna curve. On the other hand, since the skid-fin antenna is very close to the aeroplane structure, the dielectric and leakage-loss resistance should be very much greater than in the trailing-wire antenna, and hence the ordinates of the resistance curve to the right of the minimum value should be much larger. The minimum resistance for the skid-fin antenna is seen to be less than for the other in view of the shorter length of wire used and hence less ohmic resistance.¹

The very large land stations have a minimum antenna resistance between 1 and 2 ohms; the minimum resistance for the antenna of a 1-kw. set is generally between 5 and 10 ohms. Portable field antennæ sometimes have a resistance as high as 50 ohms.

What has been said of the resistance of an ordinary antenna applies to a coil radiator as well, except, of course, that the components of the total resistance are related to one another in a somewhat different way; and this is true, to a certain extent, of any one type of antenna relative to any other. The most important thing about a coil radiator is that its counterpoise or ground resistance is practically eliminated, and hence a much less total resistance is obtained. Therefore, a certain voltage will, when impressed upon a coil radiator, produce a much larger current than in a simple antenna having the same radiation resistance as the coil; hence it is possible to radiate larger amounts of power by means of the coil than one might at first think; for ordinary-sized coils, however, the frequency must be very high if appreciable power is to be radiated.

Natural Wave-length of Antenna.—Consider an antenna in its simplest form, i.e., a long vertical wire connected to the alternator as shown in Fig. 55. The antenna wire has:

- (1) Distributed inductance.
- (2) Distributed capacity.
- (3) Distributed resistance.

(1) The distributed inductance is due to the ability of every part of the antenna to develop magnetic lines of force. Assuming the absence of magnetic material near the antenna, its inductance per unit length should be practically uniform throughout its height.

¹ For a number of curves of aircraft antenna resistance see Johnson's paper in I. R. E., Vol. 8, Nos. 1 and 2.

Also see Scientific paper No. 341 of Bureau of Standards, by J. M. Cork.

(2) The distributed capacity consists of the capacity between the wire and the counterpoise, or earth, and is in general different for different parts of the antenna.

(3) The distributed resistance of the antenna is due to radiation and all the losses taking place. This total resistance per unit length of wire may be considered to be about uniform throughout the entire antenna height.

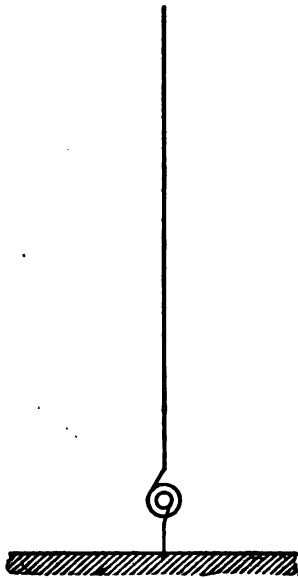

FIG. 55.—In an actual antenna the capacity inductance and resistance are distributed and must be so considered when accurate equations for current and voltage are desired.

The antenna as a whole has a certain value of effective inductance, effective capacity and effective resistance, all of which, when defined in terms of current at the base of the antenna, change with the frequency of the currents flowing through the wire. It has already been shown how the effective resistance changes with the frequency or wave-length. The effective inductance and capacity change with the frequency because, as will be presently demonstrated, the distribution of the voltage and current over the antenna changes with the wave-length or frequency. Thus, if the antenna inductance, say, is measured for a certain value of λ and some effective value of current, I_0 , at the alternator, and if, then, the wave-length is changed while the effective value of the current I_0 is maintained the same, the total magnetic flux emanating from the antenna will be different on account of the different distribution of current, and the inductance will necessarily be different. If, for instance, the effective value of the current over the antenna were as in *a*, Fig. 56 (an

impossible condition) every part of the antenna would be nearly so effective in producing magnetic flux, while if the current distribution were as in *b*, with the same current, I_0 , at the alternator, the parts of the antenna farthest removed from the alternator would not be very effective in producing magnetic flux, thus making the inductance smaller as compared with *a*.

A similar thing happens in the case of the capacity, because the voltage distribution along the antenna varies with the wave-length, and hence the ability of the different parts of the antenna to produce electrostatic lines of force varies with the wave-length.

Distribution of Current and Voltage along the Antenna Wire.—It has already been pointed out that the current and voltage cannot be the

same throughout the antenna wire of Fig. 55. The current in such a wire exists because electrons are being made to flow alternately *into* and *out* of a capacity; at the very end of the wire past which there is no capacity the current must be zero and will grow in value for points farther away from the end. The flow of this rapidly alternating capacity current (leading current) through the inductance of the antenna wire produces an increasing voltage as we proceed towards the end of the wire, a phenom-

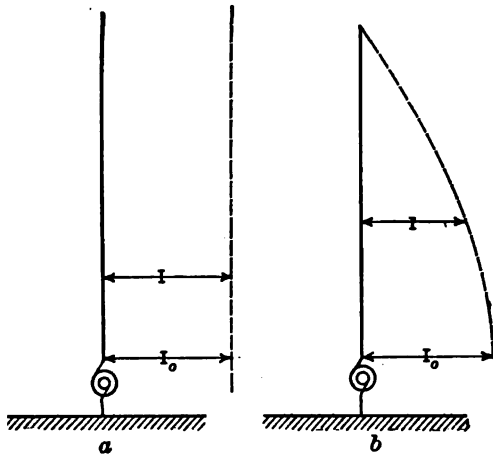

FIG. 56.

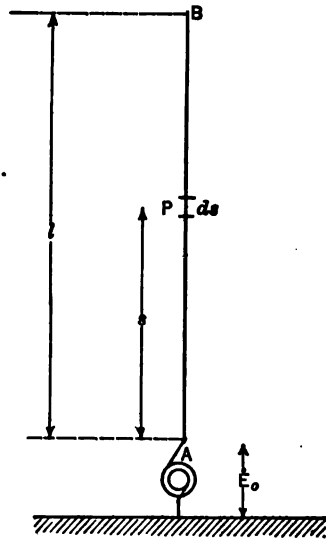

FIG. 57.

FIG. 56.—If the current at the base of an antenna is held constant while frequency is changed the distribution of current along the antenna will change; this will change the amount of magnetic energy associated with the antenna and hence will change its effective self-inductance.

FIG. 57.—By considering the leakage, capacitance, inductance, and resistance of a small element d , the equations for current and voltage may be obtained. Even if the resistance and leakage are neglected fairly accurate expressions will be obtained.

non which is well known to the electrical engineer in the case of long-distance transmission lines. In order more fully to understand the distribution of current and voltage we are giving below the expressions for the current and voltage in a simplified antenna or, more definitely, an antenna having *uniformly distributed inductance and capacity* and no resistance whatever. Thus, let AB , Fig. 57, represent such an antenna.

- Let \dot{E} = e.m.f. vector at any point P , the effective value of the e.m.f. being E ;
- \dot{I} = current vector at any point P , the effective value of the current being I ;

- s = distance from A to P , in centimeters;
- l = length of antenna in centimeters;
- L_1 = inductance of antenna in henries per centimeter;
- C_1 = capacity of antenna in farads per centimeter;
- ω = angular velocity of alternator e.m.f. in radians per sec.;
- x = inductive reactance in ohms per centimeter = ωL_1 ;
- b = capacity susceptance in mhos per centimeter = ωC_1 ;
- \dot{E}_0 = e.m.f. vector at alternator end of antenna;
- \dot{I}_0 = current vector at alternator end of antenna.

By suitable mathematical analysis¹ it may be shown that, if the antenna resistance is neglected,

$$\dot{I}_0 = j \frac{b}{\sqrt{bx}} \dot{E}_0 \tan \sqrt{bx} l. \quad (36)$$

$$E = \frac{\dot{E}_0}{\cos \sqrt{bx} l} \cos \sqrt{bx} (l-s). \quad (37)$$

$$\dot{I} = -\frac{\dot{I}_0}{\sin \sqrt{bx} l} \sin \sqrt{bx} (l-s). \quad (38)$$

If we let d = distance from the upper end of the antenna in centimeters then

$$d = l - s \quad (39)$$

call

$$a = \sqrt{bx}. \quad (40)$$

Substitute (39) and (40) in Eqs. (36), (37), (38) and we have the simple equations:

$$\dot{I}_0 = j \frac{b}{a} \dot{E}_0 \tan ad. \quad (41)$$

$$\dot{E} = \frac{\dot{E}_0}{\cos ad} \cos ad. \quad (42)$$

$$\dot{I} = -\frac{\dot{I}_0}{\sin ad} \sin ad. \quad (43)$$

From Eqs. (42) and (43) we note that both \dot{E} and \dot{I} are trigonometric functions of the distance from the upper end of the antenna d . \dot{E} varies with $\cos ad$ and \dot{I} varies with $-\sin ad$, therefore \dot{E} and \dot{I} must differ by 90° in "space phase." In Fig. 58 the abscissæ of curves \dot{E} and \dot{I} represent the values of the e.m.f. vector and current vector respectively, at various points along the antenna, obtained by the application of Eqs.

¹ See John M. Miller, "Electrical Oscillations in Antennas and Inductance Coils" Proc. I. R. E., Vol. 7, No. 3.

42) and (43). At the end of the antenna the current vector is zero while the voltage vector is a maximum. At the alternator end \dot{E} and \dot{I} may have any value, depending upon the value of \sqrt{bx} and the height of antenna. The example represented by the curves is not one which is ever purposely realized in practice, since the antenna would, in this case, produce a comparatively weak electromagnetic field, in view of the fact that the current and voltage are positive over certain portions of the antenna and negative over others; hence the effect of certain parts of the antenna would be partly or fully neutralized by other parts. The curves, however, show a more or less extreme possibility. The

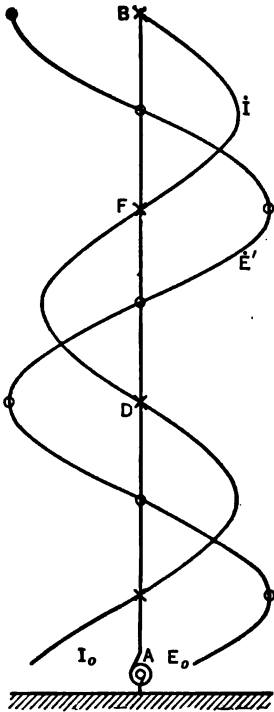

FIG. 58.

FIG. 58.—A possible form of excitation of an antenna, at a frequency much higher than its natural frequency.

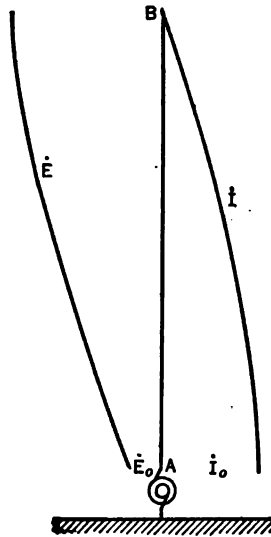

FIG. 59.

FIG. 59.—The ordinary form of voltage and current distribution on an unloaded antenna, excited at its natural wave-length.

more usual case is that represented by Fig. 59; this case will be discussed more fully a little later.

Again, we note from Eqs. (42) and (43) that, since \dot{E} and \dot{I} are trigonometric functions of ad , this quantity must represent a *space rate of change of angle*, as distinguished from ω , which represents a *time rate of change of angle*. Now, looking at the curves of Fig. 58, which represent nothing

but so-called *stationary waves* of e.m.f. and current, the distance between such points as *B* and *D* must be the length of the stationary wave over the antenna, and this distance must be such as to make

$$a\lambda_1 = 2\pi,$$

where

λ_1 = wave-length of stationary waves in centimeters,

or

$$\lambda_1 = \frac{2\pi}{a} \dots \dots \dots (44)$$

Since

$$a = \sqrt{bx} \text{ and } b = \omega C_1, x = \omega L_1,$$

$$a = \omega \sqrt{L_1 C_1} \dots \dots \dots (45)$$

If

f = frequency of alternator in cycles per second,

$$f = \frac{\omega}{2\pi} \text{ and substituting in (45),}$$

$$a = 2\pi f \sqrt{L_1 C_1} \dots \dots \dots (46)$$

The quantity $\frac{1}{\sqrt{L_1 C_1}}$ is shown in electrical engineering texts to be very nearly equal to the velocity of light or to the velocity of propagation of electromagnetic waves emanating from an antenna through the air.

If V = velocity of propagation of electromagnetic waves in cm./sec.,

$$\frac{1}{\sqrt{L_1 C_1}} = V,$$

and substituting in (46)

$$a = \frac{2\pi f}{V},$$

and finally substituting this expression for a in Eq. (44) we have:

$$\lambda_1 = \frac{V}{f} \dots \dots \dots (47)$$

Thus, the length of the antenna stationary waves, λ_1 , is equal to the velocity of propagation of the waves divided by the frequency; but this quotient represents the length of the electromagnetic waves, therefore the *wave-length of the stationary antenna waves is equal to the wave-length of the electro-magnetic waves in free space.*

Now, going back to Eq. (41) on p. 754 we may solve for the value of $\frac{\dot{E}_0}{\dot{I}_0}$, thus:

$$\frac{\dot{E}_0}{\dot{I}_0} = -j \frac{a}{b} \cot al. \dots \dots \dots (48)$$

Since E_0 and I_0 are the e.m.f. and current at the alternator their ratio must be the effective impedance of the antenna at the point where the alternator is connected. In our case the expression for this impedance is always imaginary, and therefore, represents the value of the reactance. This result was to be expected, since the resistance has been omitted in our simplified discussion.

Let X_0 = antenna reactance at the alternator in ohms.

Then

$$X_0 = -\frac{a}{b} \cot al. \quad (49)$$

Substituting for

$$a = \frac{2\pi f}{V} = \omega \sqrt{L_1 C_1}, \quad b = 2\pi f C_1 = \omega C_1,$$

we have

$$X_0 = -\sqrt{\frac{L_1}{C_1}} \cot 2\pi \frac{f}{V} l, \quad (50)$$

or

$$X_0 = -\sqrt{\frac{L_1}{C_1}} \cot \frac{2\pi l}{\lambda}, \quad (51)$$

where

λ = wave-length of electromagnetic waves, in centimeters.

The value of this reactance will apparently vary, for a fixed λ , as we vary the antenna height l . When l is such as to make $\cot \frac{2\pi l}{\lambda} = 0$, then the reactance is zero and the antenna will resonate to the alternator frequency. This will happen when:

$$\frac{2\pi l}{\lambda} = \frac{\pi}{2} \text{ or } \frac{3\pi}{2} \text{ or } (2n+1)\frac{\pi}{2}, \quad (52)$$

or when

$$l = \frac{\lambda}{4} \text{ or } l = \frac{3}{4}\lambda \text{ or } l = \left(\frac{2n+1}{4}\right)\lambda.$$

And since λ is also equal to the wave-length of the stationary antenna waves, it follows that the antenna will resonate to the frequency of the alternator when the antenna height is such that there will result a distribution of e.m.f. and current vectors which will produce either $\frac{1}{4}$ or $\frac{3}{4}$ or $\frac{5}{4}$, etc., of a stationary wave.

If the expression for X_0 as given by Eq. (50) be plotted against values of alternator frequency,¹ everything else remaining the same, we would have the curve shown in Fig. 60. At the points 1, 3, 5 the antenna reactance is zero, and the frequencies at 1, 3, 5, etc., are in ratios 1 : 3 : 5 : 7,

¹ For experimental curves showing this effect see Fig. 109, p. 109.

etc. Hence the antenna can be made to resonate at the frequency f_1 , and at frequencies three times, five times, seven times, etc., f_1 . On the other hand, a little to either side of the points 2, 4, 6, etc., the reactance is infinite and directly at the points 2, 4, 6, etc., the resistance of the antenna as measured at the base, becomes infinite so that practically no current can be caused to pass into the antenna at the frequencies f_2, f_4, f_6 , etc., which are two times, four times, six times, etc., the first resonating frequency f_1 . It is not out of place to point out here that the first resonating frequency f_1 is such as to produce one-quarter of a stationary wave over the antenna, as may be easily seen from the discussion of p. 757. The

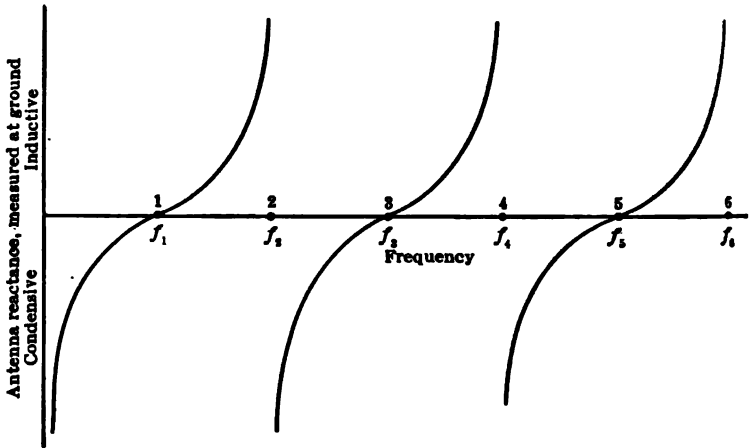

Fig. 60.—As the frequency impressed on an antenna is varied the reactance (as measured at the base) goes through the changes indicated here; in case an antenna with appreciable resistance had been considered the reactance changes from its high positive value to high negative value by going through zero values at 2, 4 and 6.

frequency and the wave-length corresponding to it are known as the *fundamental or natural frequency* and *wave-length of antenna* respectively.

An antenna if excited by means of a spark gap will naturally have currents produced in it of the frequency corresponding to zero reactance and therefore of the fundamental frequency and wave-length; it is possible by putting proper discontinuities in the antenna, to cause this frequency to be three times and even five times the fundamental. In general it may be said that, whenever the simple antenna oscillates freely, no matter how excited, it does so at the natural or fundamental wave-length.

The curves of Fig. 60 also show that the reactance of the antenna may be negative (condensive) or positive (inductive), depending entirely upon the frequency at which it is used.

In the above discussion we have assumed an antenna consisting of

a vertical wire and having distributed inductance and capacity, and no resistance. The presence of the resistance makes the results only slightly different, and so does the fact that the capacity is not quite uniformly distributed.

Consider now an actual antenna with a flat top. If the top consists of a single horizontal wire of the same size as the vertical wire, then it may be shown in the manner already illustrated for the simplest antenna that, assuming uniformly distributed capacity and inductance throughout, the total length ABC , Fig. 61, represents one-quarter of the fundamental wave-length of the antenna.

If, on the other hand, the top consists of a number of horizontal wires, as in Fig. 62, then the problem is somewhat complicated, because the

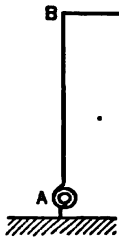

FIG. 61.

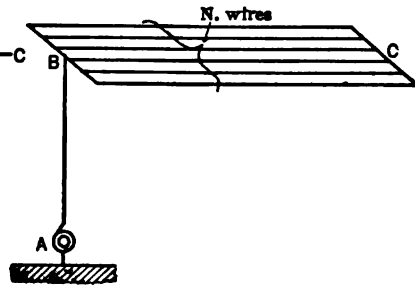

FIG. 62.

FIG. 61.—In the case of an inverted L antenna the natural wave-length is slightly more than four times the extreme length $A-B-C$.

FIG. 62.—An antenna with a wide top has a natural wave-length considerably greater than four times the extreme length $A-B-C$; by spreading out the wire $A-B$ (separating the different strands sufficiently and bringing them down in a cylindrical form) the natural wave-length may be brought down to very nearly four times the length $A-B-C$.

capacity and inductance per unit length of the part BC are different from those for part AB . However, in view of the fact that for the part BC the capacity per unit length is kn times¹ that of a single wire, while the inductance per unit length is $\frac{1}{kn}$ times that of a single wire, the product of these two quantities remains the same, and it is safe to take the distance ABC as again being approximately one-quarter of the fundamental wave-length of the antenna.

The inaccuracy of this simple rule increases as the form of the aerial departs from the simple one given in Fig. 60. It has been found experimentally that the natural wave-length is connected to the extreme length

¹ k is a constant less than unity; it approaches unity as the different wires of the antenna are spaced farther apart.

of the antenna (from ground, up lead wire to farthest point of aerial) about as given here

Vertical wire.....	4-4.11
T aerial with small tops.....	4.3- 51
T aerial with broad tops.....	5- 61
Umbrella aerial.....	6- 101
Horizontal wire, 1 meter from ground.....	51

The capacities of antennæ vary from perhaps 0.4×10^{-9} farads to 20×10^{-9} farads; the lower value being for small portable field antennæ and the higher value for large high power stations. The ordinary ship antenna has a capacity between 1 and 2×10^{-9} farads.

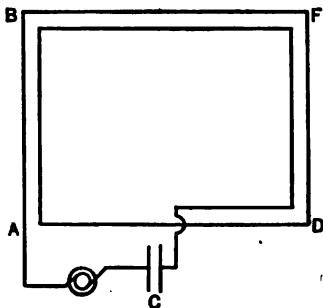

FIG. 63.—The natural wave-length of a coil antenna is seldom used; the wave-length is calculated from the value of L of the coil and the amount of capacity in C .

In the case of a coil radiator the capacity of the condenser C , Fig. 63, is generally very large as compared with the distributed capacity over the conductive $ABCD$, hence the latter may be neglected and the fundamental wave-length of the circuit may be obtained from the inductance of the coil and the capacity C .

Current and Voltage Distribution in Antenna for Various Loadings.—The expression "Loading of an antenna" applies to the insertion of an inductance or a condenser in series therewith for the purpose of changing the fundamental

wave-length of the antenna circuit. This is best understood by referring to the curves of Fig. 64, which give the reactance, at different frequencies, for an antenna, for a coil, and for a condenser. The antenna reactance curve A is the same as the first section of the curve of Fig. 60, the curve for the inductance is a straight line, since inductive reactance varies directly with the frequency, and the curve for the condenser is an equilateral hyperbola, since condensive reactance varies inversely as the frequency.

If the antenna and the coil are connected in series it is plain that the total reactance will, for any frequency, be the algebraic sum of the two individual reactances; a similar thing applies to the case where a condenser is connected in series with the antenna. The resultant reactance curves are shown as F and G . Now, considering the three curves A , F , G , it will be seen that the antenna alone has a natural frequency of f_0 , the antenna with the coil in series has a natural frequency of f_L , and the antenna with the condenser in series has a natural frequency of f_C . Thus,

the effect of the series inductance is to make the natural frequency of the entire antenna circuit smaller (larger wave-length) than that of the antenna alone, and vice versa for the case of the series condenser.

It will be noted that by making the slope of the curve *B* very great (large inductance) the antenna circuit may be caused to have a very much lower fundamental frequency than that of the antenna alone, the

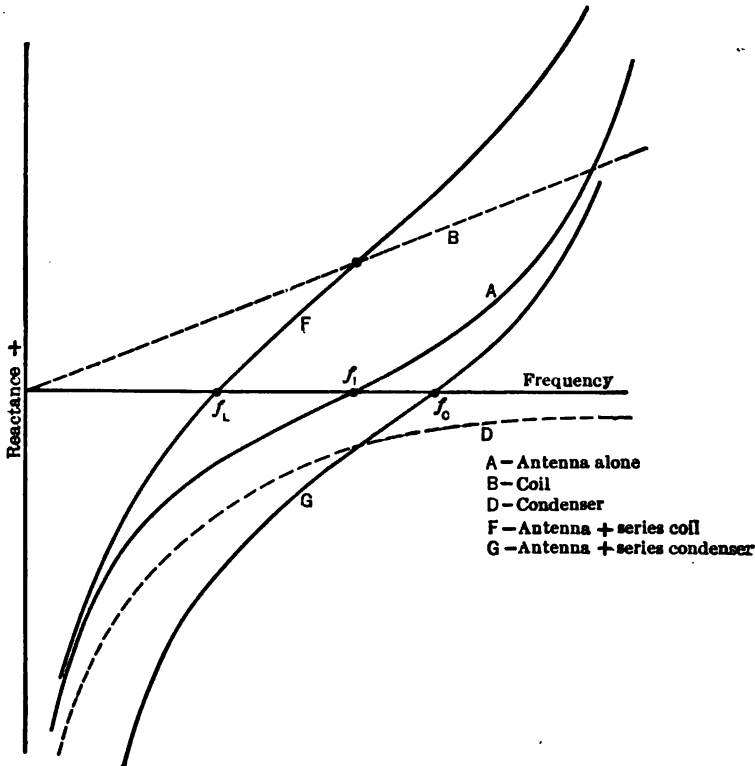

FIG. 64.—The diagram of reactances of an antenna (*A*), a coil (*B*), and a condenser (*D*), shows how the natural wave-length of an antenna circuit is changed by adding loading coil or shortening condenser in the base of the antenna.

limit being zero. In the case of the series condenser it will be observed that no matter how large we make its reactance (how small its capacity) the maximum frequency obtainable is twice that of the fundamental frequency of the antenna proper. Thus, if an antenna has a natural wave-length of, say, 500 meters, it is impossible to change this to anything less than 250 meters by placing a condenser in series with the antenna.

The changes which take place in the natural wave-length of an antenna, as various coils or condensers are used in series with it, are shown in Figs.

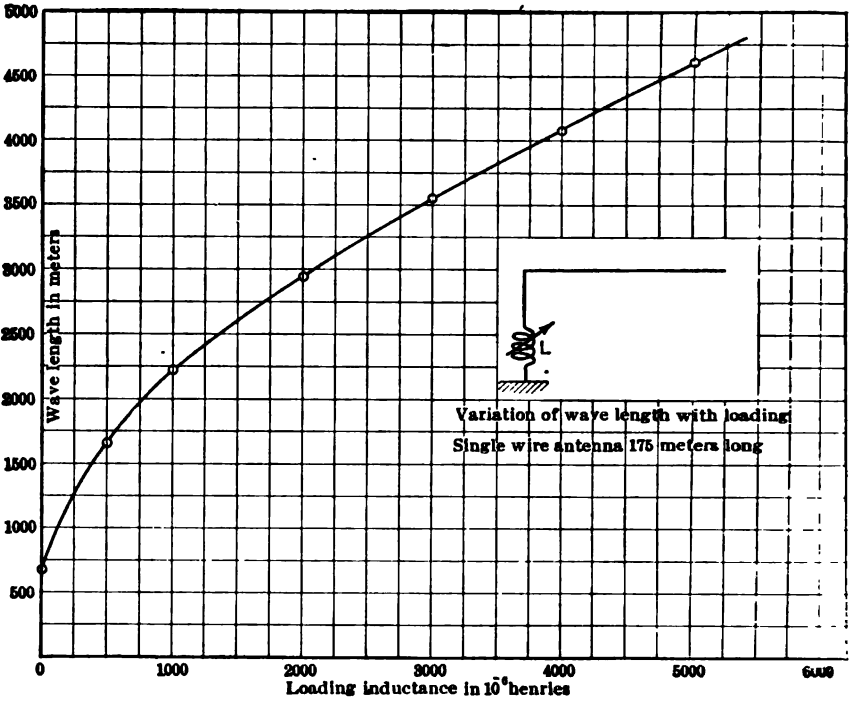

FIG. 65.—Effect of loading coil on the wave length of a single-wire antenna.

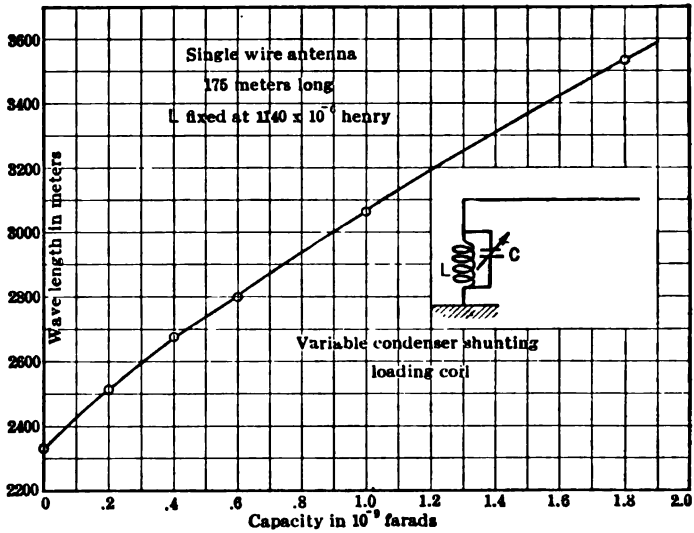

FIG. 66.—Effect of shunting the loading coil of Fig. 65 by a variable condenser.

65, 66, and 67. A single-wire antenna was used in the test, about 175 meters long, having (unloaded) a natural wave-length of 700 meters. As a variable inductance, in series with the ground connection of the antenna was changed, the natural wave-length of the loaded antenna increased as shown in Fig. 65. Then keeping the value of the loading inductance fixed at $1140 \mu h$ a variable condenser shunted around this load coil brought about the changes in wave-length shown in Fig. 66.

The effect of putting a "short-wave" condenser in series with the base of the antenna is shown in Fig. 67; it will be seen that with no capacity in series with the base of the antenna (that is, the lower end of the antenna

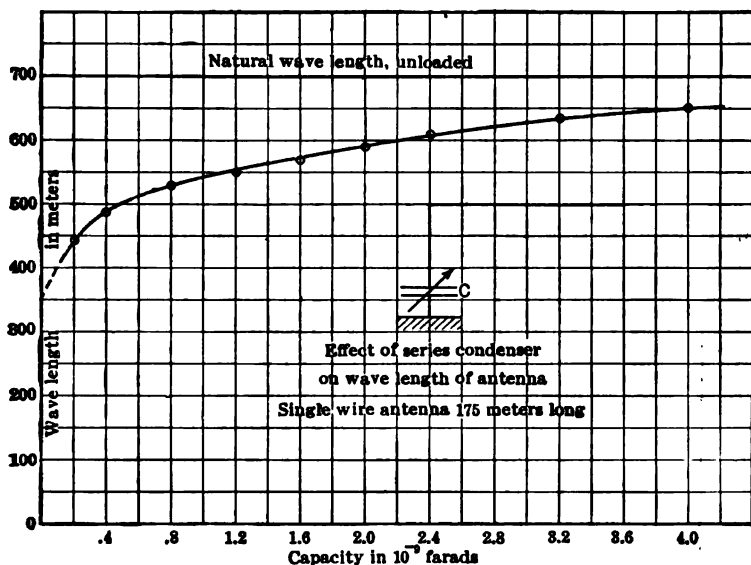

FIG. 67.—Effect of putting a variable condenser in series with the base of the antenna.

merely left free, connected to nothing) the natural wave-length decreased (by extrapolation of the curve) to half the natural wave-length of the grounded antenna.

It has already been stated that an antenna is generally used at frequencies lower than its fundamental, and therefore antennas have generally a loading inductance inserted in series. The series condenser is sometimes used in the case of receiving antennas, but very seldom for transmitting antenna

Current and Potential Distribution over Antenna.—We will consider the following cases:

- (1) Simple antenna (single vertical wire) with no loading inductance or series condenser.
- (2) Simple antenna with loading inductance in series.

- (3) Simple antenna with condenser in series.
- (4) Commercial antenna with large top and no loading inductance or series condenser.
- (5) Commercial antenna with loading inductance.
- (6) Commercial antenna with condenser in series.

It is understood that in every case the antenna circuit is operated at the fundamental frequency of the circuit, for at this frequency the reactance is zero, the resistance is a minimum, and the current a maximum.

Case (1). Eqs. (42) and (43) of page 754, give

$$\dot{E} = \frac{\dot{E}_0}{\cos al} \cos ad$$

and

$$\dot{I} = -\frac{\dot{I}_0}{\sin al} \sin ad$$

and indicate that, since the antenna height (l) is equal to one-quarter of a wave-length, the voltage and current curves will be as shown in

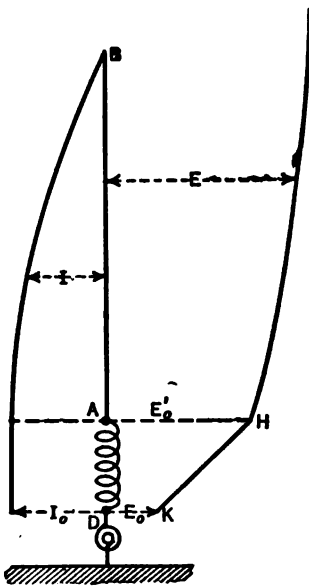

FIG. 68.—Voltage and current distribution in simple antenna with loading coil.

Fig. 59, the curves being sinusoidal; the current curve will be one-quarter of a complete sine wave.

Case (2), Fig. 68. Here the λ of the entire circuit will be larger than that of the antenna alone, therefore the antenna height will represent less than one-quarter of the wave-length. Furthermore the current through the inductance will be constant, but the voltage over it will vary from DK to AH . Hence the voltage \dot{E} at the beginning of the antenna wire will be much larger than in case (1), and the insulators at the point A will need to be such as to stand a larger voltage.

Case (3), Fig. 69. Here the λ of the entire circuit is less than that of the antenna alone; hence the antenna height will represent more than one-quarter of the wave-length. The current curve, therefore, has its zero at B , its maximum at H and decreases to I_0 at F ; it has the same value on both sides of the condenser.

The voltage curve is a maximum at B , zero at K and becomes negative thereafter; however, it again changes sign over the condenser.

Cases (4), (5) and (6), illustrated in Figs. 70, 71, and 72, are analogous to cases (1), (2) and (3), respectively, except that the distribution of voltage and current takes place over the entire antenna length and not over the vertical part alone. The result of this is that the vertical part has a current of more nearly constant effective value over the entire height; of course this result is especially desirable in view of the better radiation produced by a uniform current over the vertical wire.

Experimental curves of voltage and current distribution for a low-frequency circuit, representing at low frequency what an antenna does at high frequency, bear out the theoretical predictions already discussed, except that, whereas in the theoretical curves of Figs. 69 and 72 we have shown the effective value of the voltage to actually become zero at points marked *K*, this does not happen in the experimental curves.¹ The reason for this lies in the fact that the theoretical curves have been plotted on the basis of Eq. (37), which takes no account of the resistance of circuit, while actually there is resistance. The effect of the resistance upon the effective value of the voltage along the antenna is, generally, to make it impossible for it to become zero for, at the nodal point, where the voltage should

be zero, there is power flowing past the nodal point to supply the losses for the rest of the antenna, and in order for this to take place the voltage must be greater than zero. In the case of no resistance the voltage along

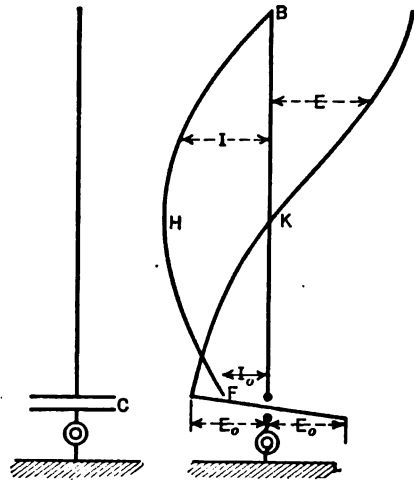

FIG. 69.—Voltage and current distribution in simple antenna with shortening condenser.

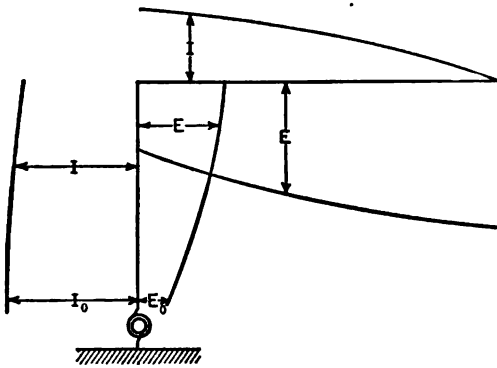

FIG. 70.—Voltage and current in unloaded inverted *L* antenna.

¹ See Morecroft, "Experiments with long electrical conductors," Proc. I. R. E., Vol. 5, No. 6, Dec., 1917.

the antenna has different effective values, but the same phase for the same half-wave and changes in phase through 180° at the point where it passes through its zero value. On the other hand, in the actual case

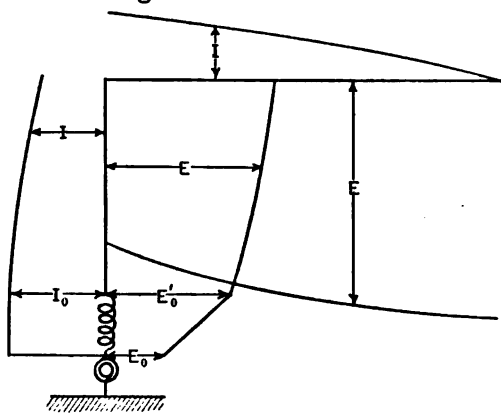

FIG. 71.—Current and voltage in inverted L antenna having a loading coil.

the voltage all along the antenna has not only different effective values, but different phases as well, as may be shown by the vector diagram of Fig. 73 where the vectors represent voltages at different points of the antenna of Fig. 72, the numbered vectors corresponding with the numbered positions on the antenna. At nodal points the voltage would be very small as shown at E_3 ; its magni-

tude (for a given impressed voltage) becomes smaller as the resistance of the upper part of the antenna is decreased.

Direction Finders.—This is the name given to receiving antennas so constructed as to indicate the direction from which the signals are coming. The simplest direction finder is a receiving coil antenna; it has already been pointed out on p. 708, that such a coil when used as a transmitter will produce the maximum intensity of field in its plane and the minimum at right angles thereto; in a similar manner the coil will, when receiving, have the greatest current produced in its circuit when its plane is in the plane of propagation of the waves and the minimum when its plane is perpendicular to the plane of propagation of the waves. Thus, if the coil be arranged so that it may be made to rotate with respect to its vertical axis while signals are being

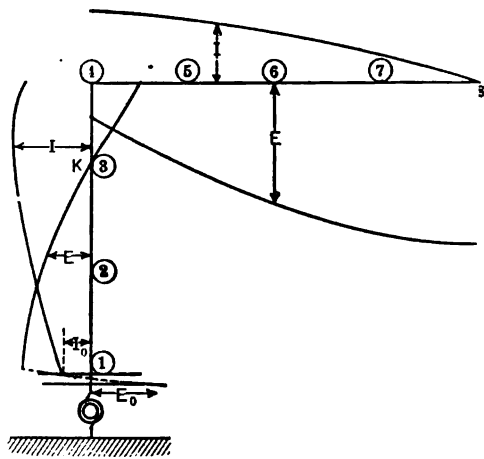

FIG. 72.—Current and voltage in inverted L antenna having shortening condenser.

made to rotate with respect to its vertical axis while signals are being

received, then when the coil is placed into a position of minimum or zero strength of signals the normal to its plane indicates the direction from which the waves are coming.

It has already been stated that in the case of aeroplanes a coil antenna is sometimes used for receiving, which is kept fixed in position with respect to the aeroplane while the aeroplane is maneuvered until minimum strength of signals is obtained.

In order to obviate the necessity of moving the coil while obtaining bearings Bellini and Tosi invented the so-called goniometer which bears their name. It consists of two similar coil antennas, Fig. 74, at right angles to each other, the antennæ being kept stationary. Each of the antennæ is connected in series with similar coils D_1 and D_2 and variable condensers F_1, F_2 , such as to enable the operator to tune to the incoming waves. The condensers are constructed so that they may both be varied at the same time and by the

same amount, in order for both antennæ to be simultaneously tuned to the incoming waves. The coils D_1 and D_2 are constructed in two parts as shown in Fig. 75, leaving a space in the middle for a coil K which may be rotated with respect to a line through O as an axis. The coil K is connected to a tuning condenser to which there is attached the detecting circuit.

The signal strength will vary as the coil K is rotated. This may be shown as follows: Let in Fig. 76 D_1, D_2 and K represent the planes of the stationary coils D_1 and D_2 and of the movable coil K respectively; also assume, for the sake of simplicity, that the coil antennæ A_1 and A_2 are placed so that the plane of A_1 is parallel to that of D_1 and the plane of A_2 parallel to that of D_2 . It is understood that the coils D_1 and D_2 together with the respective antennæ A_1 and A_2 and the condensers F_1 and F_2 (see Fig. 74) are so adjusted that each circuit has a natural wave-length equal to that of the incoming waves and the same value of resistance as the other circuit; this means that the circuits of the

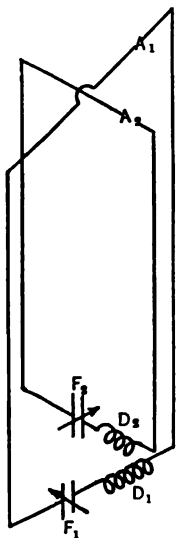

FIG. 74.—Pair of similar coil antennæ placed at right angles to each other constitute the Bellini-Tosi direction finder.

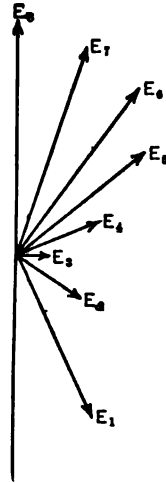

FIG. 73.—Voltage magnitudes and phases of the antennæ shown in Fig. 72; at the nodal points such an antenna of the voltage is not zero as the curves of Figs. 69 and 72 would indicate, but a certain small value depending upon the resistance of the antenna.

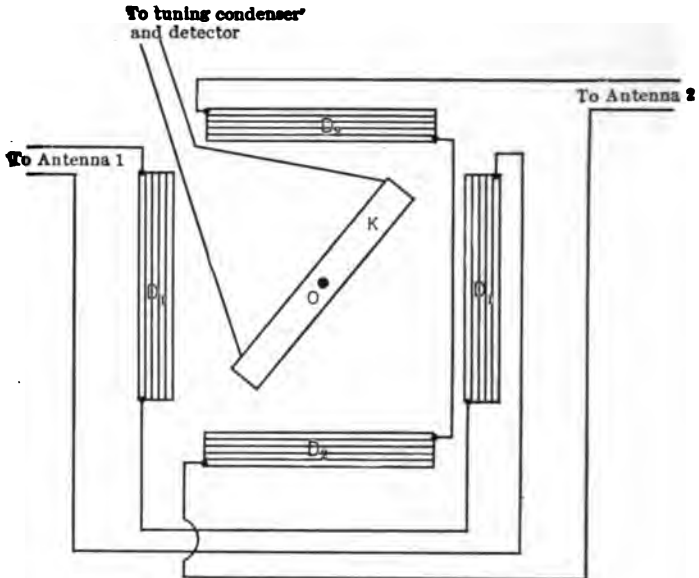

FIG. 75.—Arrangement of coils in the base of the two antennæ; coil *K* may be rotated and by the magnitude of the signal strength induced in it the direction of the sending station ($\pm 180^\circ$) can be obtained.

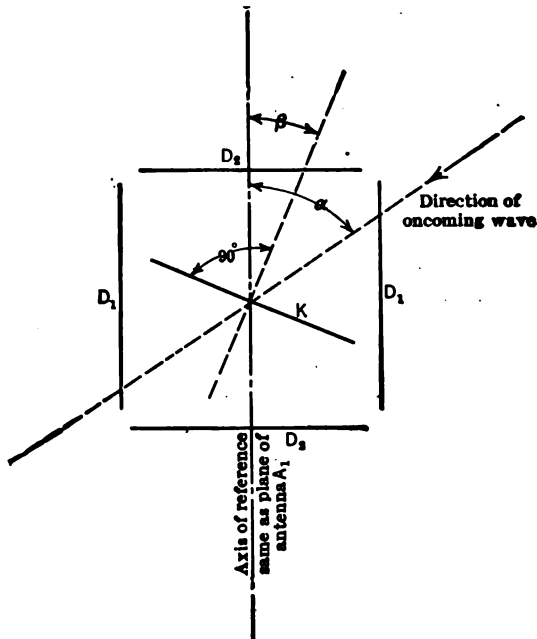

FIG. 76.—Diagram for analysis of the action of the direction finder.

two antennæ must be exactly similar. Assume that the incoming electromagnetic waves are harmonic and that, therefore, harmonic e.m.f.'s will be induced in A_1 and A_2 which will, in turn, produce harmonic currents in their respective circuits.

- Let
- α = the angle made by the direction of incoming waves with the plane of the A_1 antenna;
 - β = angle made by the normal to the plane of the revolving coil K with the plane of the A_1 antenna;
 - i_1 = instantaneous value of current in circuit $A_1-D_1-F_1$ (Fig. 74);
 - i_2 = instantaneous value of current in circuit $A_2-D_2-F_2$ (Fig. 74);
 - e_1 = instantaneous value of e.m.f. induced in K by current in D_1 ;
 - e_2 = instantaneous value of e.m.f. induced in K by current in D_2 ;
 - e = instantaneous value of total e.m.f. induced in K by the simultaneous action of D_1 and D_2 ;
 - I_m = maximum value of the current which would flow in $A_1-D_1-F_1$ or $A_2-D_2-F_2$ if either were placed with its plane parallel to the direction of the incoming waves;
 - ω = angular velocity of currents flowing in $A_1-D_1-F_1$ and $A_2-D_2-F_2$;
 - M = coefficient of mutual induction between K and either D_1 or D_2 when the plane of K is parallel to either D_1 or D_2 .

It was stated on p. 743 that the effective value (the same applies to the maximum value) of the current flowing in a receiving coil antenna, whose plane is inclined to the direction of the incoming waves, is equal to that which would flow, were its plane parallel to the direction of the waves, multiplied by the cosine of the angle which the direction of the waves makes with the plane of the coil. In our case, therefore, we have:

$$i_1 = I_m \cos \alpha \sin \omega t \quad \dots \dots \dots (53)$$

By imagining that D_1 is rotated (counter-clockwise) until it coincides with position shown for D_2 , we see that the equation for current in coil D_2 must be

$$i_2 = I_m \cos (\alpha + 90) \sin \omega t = -I_m \sin \alpha \sin \omega t. \quad \dots \dots (54)$$

From the well-known law of electromagnetic induction

$$e_1 = -M \sin \beta \frac{di_1}{dt} \quad \dots \dots \dots (55)$$

$$e_2 = -M \cos \beta \frac{di_2}{dt} \quad \dots \dots \dots (56)$$

Substituting in (55) and (56) the values of i_1 and i_2 of (53) and (54) we have:

$$e_1 = -\omega MI_m \cos \alpha \sin \beta \cos \omega t, \quad \dots \dots \dots (57)$$

$$e_2 = \omega MI_m \sin \alpha \cos \beta \cos \omega t, \quad \dots \dots \dots (58)$$

and

$$e = e_1 + e_2 = -\omega MI_m \cos \omega t (\cos \alpha \sin \beta - \sin \alpha \cos \beta). \quad \dots (59)$$

The maximum value of e for a given value of α and β evidently occurs when $\cos \omega t = 1$ or

$$\text{Max. value of } e = \omega MI_m (\cos \alpha \sin \beta - \sin \alpha \cos \beta). \quad \dots (60)$$

Since the maximum value of the current flowing in the coil K is directly proportional to the maximum value of e , and since this latter changes as the angle β is changed, i.e., as the position of K changes, it follows that the signal strength will vary as K is rotated about its axis.

We may now find the values of β which will make the signal strength zero or a maximum respectively; this will occur when the value of the parenthesis of Eq. (60) is zero or a maximum.

We can put $\cos \alpha \sin \beta - \sin \alpha \cos \beta = \sin (\beta - \alpha)$ and then get

$$\begin{aligned} \sin (\beta - \alpha) = 0 \text{ when } \beta - \alpha = 0^\circ \text{ or } 180^\circ \\ \text{from which } \beta = \alpha \text{ or } = 180^\circ + \alpha. \quad \dots \dots (61) \end{aligned}$$

$$\begin{aligned} \sin (\beta - \alpha) = \text{maximum when } \beta - \alpha = 90^\circ \text{ or } 270^\circ \\ \text{from which } \beta = 90^\circ + \alpha \text{ or } = 270^\circ + \alpha. \quad \dots (62) \end{aligned}$$

We may therefore state that extinction of the signals will take place when the normal to the plane of the coil K is parallel to the direction of the incoming waves, and that maximum strength of signals will result when the normal to the plane of K is at right angles to the direction of the incoming waves. It will be noted that, in this particular case, where D_1 and D_2 are parallel to A_1 and A_2 respectively, the results are the same as if the whole system of coils were reduced to the coil K alone used as a coil antenna; for, when the plane of K is perpendicular to the direction of the waves, the strength of signals is a minimum, and when the plane of K points towards the direction of the waves, the strength of signals is a maximum.

A discussion similar to the one given above may be applied in a similar manner and with similar results to the case of damped waves. Of course it is plain that the results expressed by Eqs. (61) and (62) are vitiated by the existence of any dissimilarity between the circuits $A_1-D_1-F_1$ and $A_2-D_2-F_2$. In order to avoid any dissimilarity as much as possible, even at the expense of sensitiveness, the condensers F_1 and F_2 are often dispensed with, and the circuits are thus made aperiodic.

By fitting coil K with a suitably calibrated dial and rotating the coil until weakest signals are obtained, the direction of the incoming waves may be determined with a comparatively small percentage of error. Use

has been made of the direction finders for determining the position of a ship or aircraft of some kind. Thus, in the case of a ship *S* which is nearing the port, the ship may get her bearings quite accurately in one of two ways, as indicated below:¹

(a) The ship may be fitted with a directional receiver, and the stations *A*, *B*, *C*, *D* may be fitted with non-directional transmitters continually sending out different identifying letters. The operator on board the ship is assumed to know the positions of the stations *A*, *B*, *C* and *D* on his chart. He would obtain the angles α , β , γ (see Fig. 77) by manipulating his directional receiver. By plotting the points *A*, *B*, *C*, *D* and the angles α , β , γ the position of the ship may be obtained.

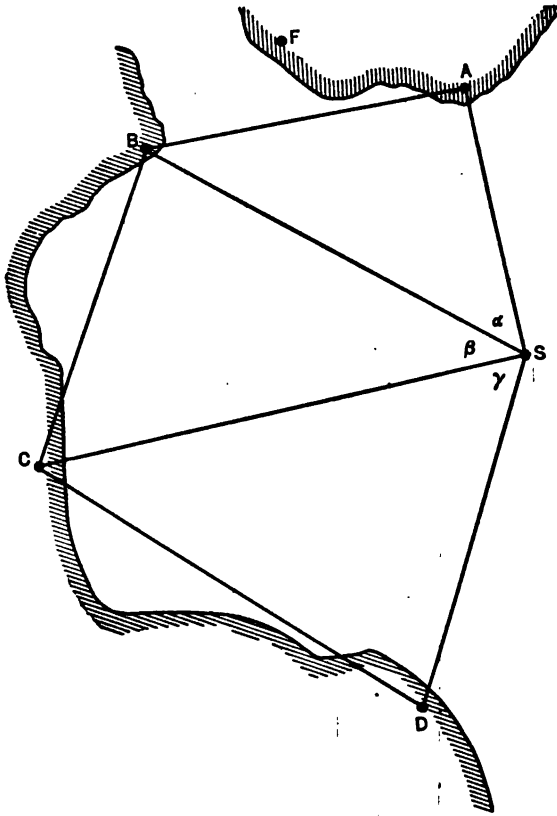

FIG. 77.—Arrangement of shore station around a port to furnish radio compass service to incoming ships.

(b) The ship may be fitted with a non-directional transmitter continually sending out some identifying letter, and the stations *A*, *B*, *C*, *D* may be fitted with directional receivers. The operators at *A*, *B*, *C*, *D* would, by manipulating their directional receivers, obtain the angles which the lines *SA*, *SB*, *SC*, *SD* make with the north and south line and report these angles by telephone to a central station *F*, where the angles are plotted and the position of the ship is determined. Station *F* will then transmit the position of the ship by radio to the operator on board the ship.

¹Ships desiring radio compass service must be fitted to receive on 450 meters in American ports and 800 meters in European ports; thus a ship sailing from American ports should now have receiving equipment calibrated at 300 and 600 meters (mandatory) as well as 450 and 800 meters.

This latter method is the one used in the port of New York and seems to be preferable to the former, in so far as this requires the presence of a skillful operator, capable of plotting the ship's position, on board each ship, whereas in the other case all the plotting is done in one single central station, where much greater accuracy may be obtained.

So far we have shown how, by means of the single coil antenna or by means of a goniometer, we may be able to determine the plane parallel to which the electromagnetic waves are acting; but we have not yet determined the exact direction of the incoming waves. Thus, we have been able to find that the waves may be acting along the line AB , but not whether they are coming from A or from B ; this determination is technically known as the "elimination of the 180° uncertainty." In most instances the direction from which the waves are coming is known, especially in communication between ship and shore and vice versa; but sometimes this is not the case.

In order to eliminate the 180° uncertainty the single-coil antenna or the double-coil antenna of a goniometer is accompanied by a vertical-wire antenna located in the axis of the coil or coils, as shown for the case of the single coil antenna of Fig. 78, where $ABCD$ is the coil antenna FG the vertical-wire antenna, connected to ground in series with the tuning inductance H and the key K . The inductance H is loosely coupled to the coil N inserted in series with the coil antenna. The operation of obtaining the direction of the incoming waves would be as follows:

(1) With key K open and the coil antenna turned into some position where the signals may be easily heard, tune the coil antenna circuit to the incoming wave-frequency by means of condenser P .

(2) Close K , and, without changing condenser P , adjust H until the circuit of the vertical wire antenna is tuned to the frequency of the incoming waves, which will be denoted by maximum noise in the receivers connected in the detecting apparatus.

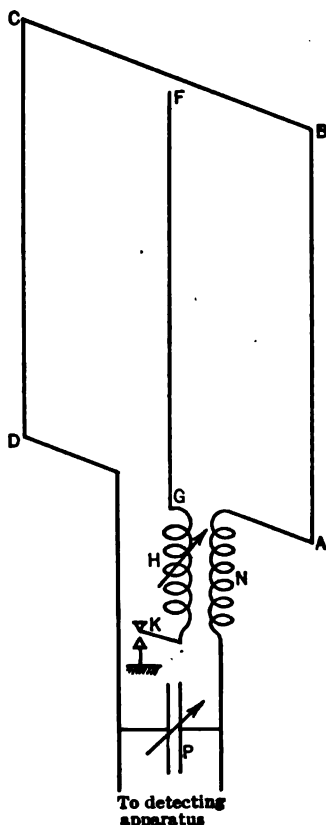

FIG. 78.—To eliminate the 180° uncertainty it is necessary to use a simple antenna in connection with the coil antenna.

(3) Again open key *K*. Turn the coil antenna until the signals disappear or become a minimum. The normal to the plane of the coil when in this position represents a line parallel to the direction of the incoming waves.

(4) With key *K* still open turn the coil antenna 90° from position of (3). Maximum signal strength will then be obtained.

(5) With the coil antenna in the position of (4) depress key *K*. The signal strength will either increase or decrease relative to that of (4), depending upon the exact direction from which the waves are coming. If the signal strength decreases upon closing *K* the waves are coming from a certain direction, and if it increases the waves are coming from the opposite direction. Whether it is one direction or the other may be told by previously calibrating the entire apparatus. Waves are used for this calibration which are known to come from a definite direction.

The reason for the behavior of the vertical-wire antenna together with the coil antenna is as follows: Consider Fig. 79 and let the arrows represent the assumed positive directions of the electromotive forces in the wires *AB*, *FG*, *CD*. Let the direction of the incoming waves be as represented by *W*, and let the plane of the coil be parallel to the direction of the waves.

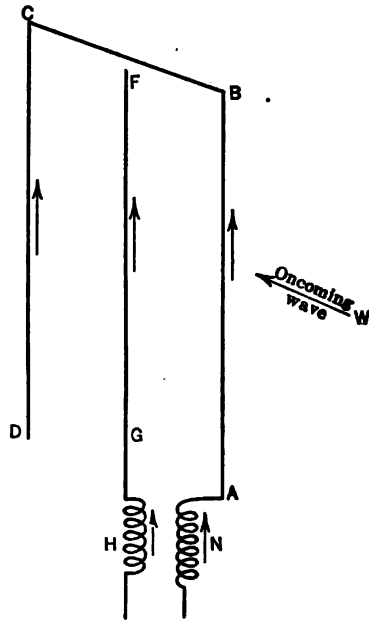

FIG. 79.—Direction of assumed positive e.m.f. induced in the conductors of the two antennæ of Fig. 78.

- Call
- E_1 = effective value of e.m.f. produced in wire *AB* due to waves *W*;
 - E_2 = effective value of e.m.f. produced in wire *FG* due to waves *W*;
 - E_3 = effective value of e.m.f. produced in wire *CD* due to waves *W*;
 - α = angle equivalent to distance S_1 between *AB* and *FG*, and between *FG* and *CD*;
 - E = effective value of total e.m.f. in coil antenna due to waves *W*;

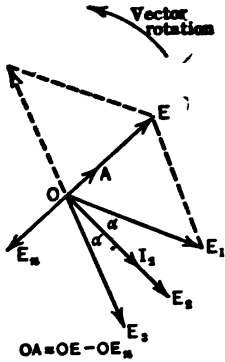

FIG. 80.—The e.m.f. acting in the coil antenna (Fig. 79) is the vector difference of the e.m.f. in its two sides and is shown at OE ; current flowing in the simple antenna is shown at OI_2 and this induces a voltage in the coil antenna equal to OE_n .

I_2 = effective value of current produced in the vertical wire antenna;
 E_n = effective value of e.m.f. induced into N by the current in H .

Since the waves strike wire AB first it is plain that the e.m.f. produced therein will be ahead of that of FG and CD and, therefore, the various e.m.f.'s will be as shown in Fig. 80 below, where:

$$\dot{E} = \dot{E}_1 - \dot{E}_3$$

It is plain that no matter what the angle α the vector E will always be at right angles to E_2 . The current I_2 will, since the wire antenna is tuned to the incoming waves, be in phase with the e.m.f. E_2 . The e.m.f. E_n induced in N will be 90° behind the current I_2 or 180° from the e.m.f. E . Since the total e.m.f. producing the current in the coil antenna is $E - E_n$, this e.m.f. will, in this case, be OA , less than if the coil antenna alone were acting, when the total e.m.f. would be E .

Now consider the case when the waves are coming from the opposite direction to W . Let the symbols: $E'_1, E'_2, E'_3, E', I'_2, E'_n$ represent quantities corresponding to $E_1, E_2, E_3, E, I_2, E_n$, with the waves from the direction opposite to W . In this case the waves will strike conductor CD first, and hence the e.m.f. produced therein will lead the e.m.f.'s of FG and AB . The vector diagram will then be as shown in Fig. 81. As before $\dot{E}' = \dot{E}'_1 - \dot{E}'_3$ and will be always perpendicular to E'_2 . The e.m.f. E'_n will now be in phase with E' and the total e.m.f. $(\dot{E}' + \dot{E}'_n)$ producing the current in the coil antenna will, in this case, be OA , larger than if the coil antenna alone were acting, when the total e.m.f. would be E' .

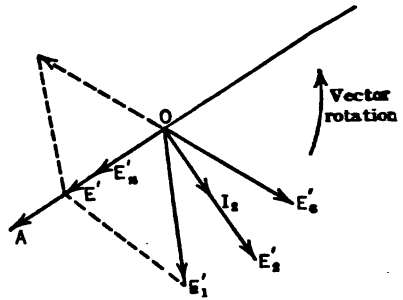

FIG. 81.—This diagram shows how the phase relations of the various e.m.f. of Fig. 80 change if it is assumed that the signal waves are coming from the opposite direction to that assumed in Fig. 81

Thus it has been shown that if the waves are coming from W , Fig. 80, the action of the current in the vertical-wire antenna is to diminish the current in the coil antenna (and hence the strength of signals), while if the waves

are coming from the opposite direction the action of the vertical-wire antenna is to increase the strength of the signals. It will be understood that whether the signal strength is increased or decreased by the action of the vertical-wire antenna will depend not only upon the direction of incoming waves, but also upon the direction of the winding on the coils *I* and *N* and the position of these coils relative to each other. This is the reason why the entire apparatus has to be calibrated beforehand. In the case of a goniometer the vertical wire antenna is coupled to both of the coil antennæ, and the manipulation of the apparatus is similar to that for the single-coil antenna.

Incomplete Extinction of Signals.—Unless special precautions have been taken coil antennæ do not give zero signal, in any position; the signal goes to a minimum, but is not extinguished. This effect is produced by the coil acting to some extent like a simple antenna. The two wires leading from the coil to the detecting apparatus unbalance the coil electrically, one of them going directly to ground (filament circuit of detecting tube) and the other connecting to ground only through a very high impedance. This asymmetry is sufficient to prevent a "silent" setting to be made with the coil, because the antenna effect gives an *m.f.* 90° out of phase with the coil effect. By a suitable auxiliary circuit it is possible to eliminate this antenna effect, thus getting a more accurate setting, if necessary.

Reliability of Direction Finders.—The precision with which a direction-finding receiving coil can be set (under laboratory conditions) is probably less than 1° ; in general an operator can set more precisely for minimum signal strength than for maximum unless two coils, at right angles to each other, are used and one of them arranged for commutation. In this scheme the combination of coils is so placed that one coil (the one without the commutator) lies approximately in the direction of the signal, thus being set for maximum reception. The other coil (evidently set for minimum signal) is connected in series with the first by means of the commutator. The operator then orients the apparatus until the commutation of the one coil makes no difference in the signal strength. The precision of setting with this apparatus is probably much better than 1° .

It would seem that it is not worth while to increase the precision of direction finders beyond that now attainable, because of the non-linear propagation of radio waves. With short waves there is not much deviation from straight line propagation, under ordinary conditions; with the long-wave-signals, however, the propagation seems to be rather erratic.¹ With signals from 10,000–20,000 meters long, an apparent change in

¹See Bureau of Standards Scientific Paper No. 353, reporting experiments by H. Taylor.

direction of a transmitting station of as much as 90° may occur, the change occurring quite rapidly (as much as several degrees per minute). This variation occurred when the two stations were less than 200 miles apart and might, of course, been greater if the distance had been greater. The change in direction is undoubtedly due to refractions caused by conditions of conductivity in the atmosphere, and surface conditions; one might expect, for example, large deviations when transmitting along a shore line.

In view of Taylor's experiments it seems hardly advisable to use highly directional receiving antennæ for communication between long-wave stations. It would seem as though many experiments on attenuation measurement with long waves must be of extremely doubtful value, if the receiving antenna was at all directional.

Setting up the Steady State in an Antenna.—It has been noted previously that after the sending key is depressed it may be an appreciable time before the current reaches the value predicted by the steady state equations; some of the effects obtained are shown in Figs. 82, 83, and 84. In getting the film shown in Fig. 82 the impressed frequency was such as to set the artificial antenna into quarter wave-length oscillation; the three curves on the film show the voltage impressed, voltage half way along the antenna, and voltage at the open end. They are not shown in the film to the same scale as the voltage at the open end measured 345 volts, that at the middle 212 volts while the voltage impressed was only 20 volts.

It took this artificial antenna about 20 cycles to obtain its steady state values; in an actual antenna it may take 100 cycles or more before the steady state is reached, i.e., before normal radiation is established.

By examination of the film it may be seen that the voltage at the base (a nodal point) is 90° out of phase with the voltage at the end of the antenna; this is in accordance with the ideas brought out in discussing Fig. 73.

In getting the film of Fig. 83 the frequency was increased to three times the value for quarter wave-length oscillation. It may be found from measurement of the film that it took the first pulse three-quarters of a cycle to travel from the beginning of the antenna to the end. Furthermore, it may be noted that in the steady state the voltage at *C* (end of antenna) is 180° out of phase with the voltage at *B*, as predicted in Fig. 73, and voltage at *A* is 90° out of phase with the voltage at *B*.

In establishing the steady state it may happen that one section of the antenna builds up to a voltage higher than it has in the steady state; this is indicated in Fig. 84 in which the impressed frequency had no particular relation to the fundamental frequency of the antenna.



Fig. 82.—The film shows how the “steady state” is set up when an antenna is first excited; curve A shows the voltage impressed, B the voltage at the middle and C the voltage at the open end. Voltage impressed = 20, voltage at B (steady state) = 212, voltage at the end of the artificial antenna = 345.



FIG. 83.—Here the artificial antenna was forced to vibrate at three times its fundamental frequency; it will now be noted that the voltages at B and C are in opposite phase in the steady state. From the film it can be seen that the original pulse arrives at C one-half a cycle after passing point B.

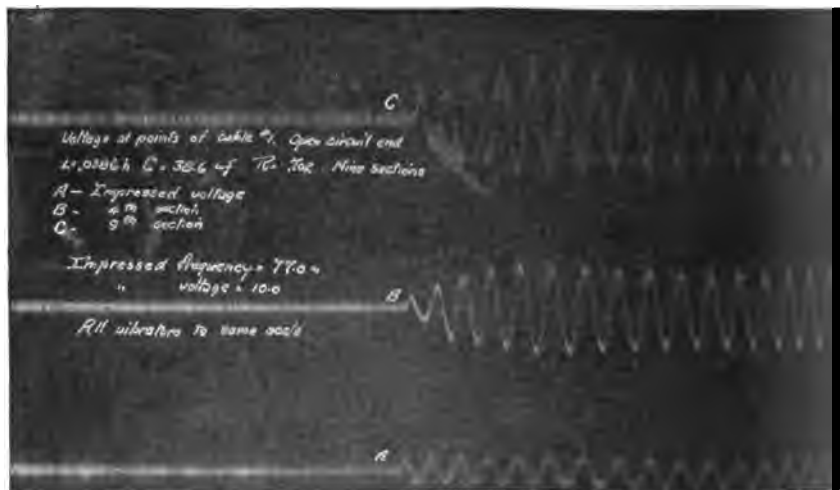

FIG. 84.—While the steady state is being set up some sections of the antenna may carry currents greater than the steady state values.

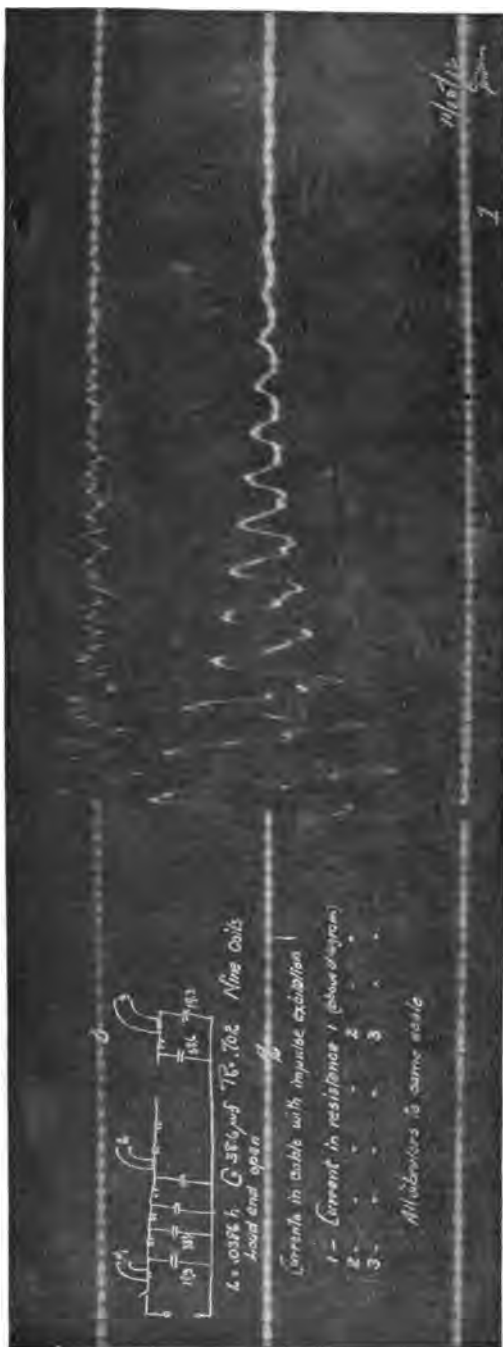

FIG. 85.—This film shows how an antenna is affected by a pulse; a unidirectional pulse of current, shown in the lower curve, was impressed on the antenna, and the current set up in the antenna is oscillatory.

Effect of Pulse Excitation of an Antenna.—In Fig. 85 is shown the effect of putting a square pulse of current into the antenna and then disconnecting the antenna from earth; an oscillatory current is set up in the antenna (as shown by the middle curve) the frequency of which for the conditions used is that of the half wave-length oscillation of the antenna. Thus pulses of “static” always excite an antenna to oscillate at its natural period.

CHAPTER X

WAVE-METERS AND THEIR USE

Relation between Frequency and Wave-length.—It has already been shown (see p. 183) that a definite relationship exists between the wave-length of the energy radiated, the frequency of oscillation, and the velocity of propagation, which may be expressed as follows

$$\lambda = \frac{V}{f},$$

here λ = wave-length in meters;
 V = velocity of propagation in meters per second;
 f = frequency of oscillations in cycles per second.

Since the velocity of propagation V is the same for all cases, i.e., $\times 10^8$ meters per second, corresponding to the speed of light, the wave-length may thus be immediately determined, if the frequency is known, and vice versa.

Principle of the Wave-meter.—Therefore, an instrument by means of which the frequency may be determined may also be used to measure the wave-length, and instead of having its indicating scales graduated in frequencies, may have them calibrated directly to read the wave-length. Such an instrument is called a wave-meter, and represents the most useful and important measuring device employed in radio-engineering. The instrument consists fundamentally of a circuit, the natural frequency of which is adjustable and known at all settings. This circuit is brought into resonance with the frequency to be measured, which may then be read at once from the setting of the wave-meter (indicated in wave-length).

In its usual form, it consists of a simple series circuit, containing an inductance and a capacity and an indicating device, e.g., a hot-wire ammeter, to show the resonant condition. This circuit is shown in Fig. 1.

For varying the natural frequency of the circuit, the capacity is usually made variable, as being the more practical and convenient, while the

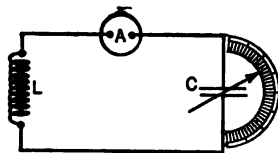

FIG. 1.—The simplest wave-meter consists of a fixed coil, L , of as low resistance as feasible, in series with a continuously variable condenser C , and a hot-wire ammeter, A , for indicating resonance.

inductance is fixed in value. The relation between natural frequency, wave-length, and the circuit constants has already been derived (see page 212) as

$$f = \frac{1}{2\pi\sqrt{LC}} \text{ cycles per second}$$

where L and C are measured in henries and farads,

and

$$\lambda = 1885\sqrt{LC} \text{ meters}$$

in which L and C are measured in microhenries and microfarads.

As the condenser capacity is varied, a pointer attached to the moving element, moves over a graduated scale, which may be calibrated to indicate the natural frequency of the circuit at the different settings. Usually, the scale is calibrated in wave-lengths, as already mentioned, due to the custom of expressing frequencies in terms of wave-length.

Extending the Wave-length Range.—Assuming a coil of constant inductance L , the wave-length range which may be covered by the meter is limited by the maximum and minimum values of the variable condenser and the internal capacity of the coil being used. The wave-meter may be required to measure wave-lengths from very small values, for example, 50 meters, up to wave-lengths of 10,000 meters and above, and to attempt to cover this range with one value of inductance would require a very large variable condenser, with a correspondingly crowded scale, and determinations would be difficult and inaccurate. It is therefore usual to supply several coils of different inductance with the instrument, the larger values of inductance being inserted in the circuit, when higher wave-lengths are to be determined. Similarly, the smaller inductances would be used in small wave-length measurements.

To increase the range beyond the maximum and minimum wave-lengths, which can be measured with the inductances supplied with the instrument, the procedure would be as follows, assuming that the inductance of the coils supplied is not known.

For Wave-lengths below the Minimum Range.—Assume the *maximum* wave-length which can be measured with the lowest wave-length coil in circuit as 100 meters. Adjust some exciting source to radiate at 50 meters, the wave-meter being loosely coupled to the radiating circuit, which may be a transmitting set or a simple buzzer-excited circuit. Estimate the coil inductance as accurately as possible from the dimensions and turns of the coil in circuit, and construct a coil with approximately one-quarter (or somewhat greater) of this inductance. Insert this new coil in circuit in place of the standard coil, and again couple loosely to the radiating circuit, which is still adjusted to radiate at 50 meters. It should be found that the wave-meter is now in resonance with the variable condenser adjusted to about the 100-meter graduation.

If it is desired to have a definite proportionality between the readings obtained with the new and old coil (for example 2 to 1), remove turns from the improvised coil until resonance occurs when the capacity is set at 100 meters. The true wave-length being 50 meters, a multiplying factor of $\frac{1}{2}$ must thus be applied to all readings obtained when using the new coil. The maximum wave-length of the new minimum wave-length coil has therefore been cut in half, and low wave-length determinations may now be more easily and accurately made. Of course it is not necessary to make the new coil have such an inductance as to cut the wave-length scale in two. Suppose that the new coil gives resonance with the wave-meter set at 97 meters; then the proper wave-length reading for the new coil will be $50/97$ that for the smallest wave-meter coil.

For Wave-lengths above the Maximum Range.—For this case the procedure is exactly as outlined above, with the exception that the inductance would be increased instead of decreased. Thus if the range is to be doubled, and the maximum wave-length with the maximum inductance L in circuit was 2000 meters, the inductance to be added to the circuit would be $3L$ (the total inductance thus being $4L$), and the maximum wave-length which could be measured, thus doubled to 4000 meters. Calibration would be carried out by adjusting a sending set to radiate at 2000 meters, and then adjusting the added inductance until resonance is indicated at the 1000-meter mark. A multiplying factor of 2 must then be applied, to obtain the true wave-length from that indicated on the condenser scale, and the wave-length range has therefore been doubled.

If the inductances of the coils furnished with the instrument are accurately known (this is usually the case), and means are available to construct accurately the desired additional inductances, the laboratory calibration described above would not be required. It would be desirable, however, to make a check measurement in all cases when possible.

Schemes for Indicating Resonance.—The wave meter circuit will be in resonance when its natural frequency coincides with the frequency of the induced e.m.f., or when

$$f_{\text{induced e.m.f.}} = f_0 = \frac{1}{2\pi\sqrt{LC}}$$

Under this condition, the impedance of the wave-meter circuit, will be a minimum (loose coupling assumed) and will be equal to the effective resistance R of the circuit. Thus the current will be a maximum and any device whose indications, whether audible or visible, vary with the current value, may be used as a means of indicating the resonant condition.

The following devices are applicable for this purpose:

- a. Hot-wire ammeter.
- b. Crystal detector and phones.

- c. Thermo-couple and galvanometer.
- d. Crystal detector and galvanometer.
- e. Tube filled with rarefied gas (neon).
- f. Small incandescent lamp.

a. *Hot-wire Ammeter*.—This instrument may be connected directly in series in the circuit as shown in Fig. 1, or may be shunted across one or more turns of the inductance, as shown in Fig. 2.

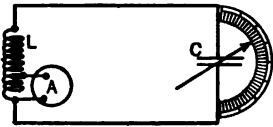

FIG. 2.—Sometimes the sensitive, high-resistance, ammeter used in a wave-meter is shunted across a few turns of the inductance as this may introduce less resistance in the wave-meter circuit than if the meter were connected directly in series, as in Fig. 1.

The latter scheme is more usually employed, due to the high resistance of the ammeter. The instruments used in wave-meters are never called on to measure very large currents, as the current may always be limited by the coupling between the wave-meter and the exciting circuit. The current carrying element (see below) is therefore of rather fine wire, and possesses considerable resistance, which, if placed directly in series in the circuit, would seriously increase the meter decrement, as discussed later.

The ammeter should be made as sensitive as possible so that large deflections may be obtained without coupling the meter too closely to the circuit being tested. It consists essentially of a very thin wire or strip, through which the circuit current, or portion thereof, passes. The wire is under tension and as it expands, due to the heating effect of the current flowing through it, it causes a shaft to rotate. The pointer of the instrument is rigidly attached to this shaft. This arrangement is indicated in Fig. 3.

The heat loss in the wire, and therefore its elongation and the meter indication is evidently proportional to I^2 . In order that the pointer deflections be truly proportional to I^2 , it is necessary that R should be constant over the frequency range at which the instrument will be used. For this reason very thin wire is employed, having negligible skin effect. The resistance, however, is correspondingly high, and it is for this reason directly, as already mentioned. A typical sensitive instrument, e.g., has a resistance of 8 ohms and gives full scale deflection with 30 milliamperes.

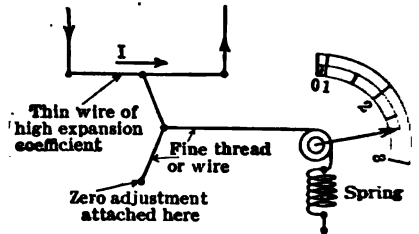

FIG. 3.—Sketch showing how the average hot-wire meter is constructed; sometimes the expansion of the wire is still further magnified by one more strong attachment.

It should be noted that in the various measurements used with wave-meters it is not necessary that the absolute value of current be known, but only relative values are required, therefore there is no objection to connecting the meter in shunt, since the variations in frequency are so small during any one measurement that the accuracy of the result is not affected (due to change in the shunt impedance).

When the current to be measured exceeds 3 amperes, as for instance the antenna current of a transmitting set, the size of the wire required, were it attempted to use but one conductor, would be so large that its resistance would no longer be independent of frequency. For this case a squirrel-cage element, consisting of a number of fine wires or strips connected in parallel, is used. See Fig. 12, page 123.

For currents larger than 20 amperes a current transformer may profitably be employed. This transformer may be air- or iron-cored, the latter being used to the greatest extent, as it insures close coupling between the primary and secondary turns. The core is of toroidal form, made of very thin iron plates, and at radio frequencies the current ratio is given approximately by the turn ratio, i.e.,

$$\frac{I_1}{I_2} = \frac{n_2}{n_1}$$

where, n_2 = number of secondary turns in series;
 n_1 = number of primary turns in series;
 I_2 = secondary current;
 I_1 = primary current.

It has already been noted that the deflections of the hot-wire ammeter are proportional to I^2 , or to the watts (I^2R) lost in the instrument itself. For this reason it has been erroneously called a watt-meter, when the scale is graduated in (amperes)² and not in amperes. The ammeters used in modern wave-meters are graduated in either of these ways, in fact, the (ampere)² graduation is the more convenient for certain measurements. It should, however, be clearly kept in mind that the instrument is not really a watt-meter in the ordinary sense; the scale calibration generally gives the watts *used in the instrument itself*.

b. *Crystal Detector and Phones*.—The hot-wire ammeter is applicable only when the wave-meter is to be coupled to a circuit of considerable power, so that appreciable currents are caused to flow in the wave-meter circuit. When the induced currents are exceedingly small, as when the wave-meter is coupled to a receiving antenna, or a buzzer-excited wave generator, only the most sensitive of current indicating devices may be used. The crystal detector and phones, which have already been described in connection with the reception of spark signals (see page 339)

are eminently suited for this purpose, and various schemes for connecting these into the wave-meter circuit have been tried. These schemes are shown in Fig. 4, which also shows the relative sensibility of the different arrangements.¹

Scheme No. 1 is probably the most generally used, and its operation and action is exactly similar to that involved in the reception of spark signals (see page 339). It illustrates what is known as the "direct" connection of the detector and phones. Circuit No. 4 represents what is called the "unilateral" connection, the phones and detector being connected in a closed loop, which is connected to the wave-meter circuit at one point only. This scheme is not used to any great extent, due to its poor sensibility, but possesses an advantage in that the calibration of the wave-meter is not affected appreciably, by the character of the detector-

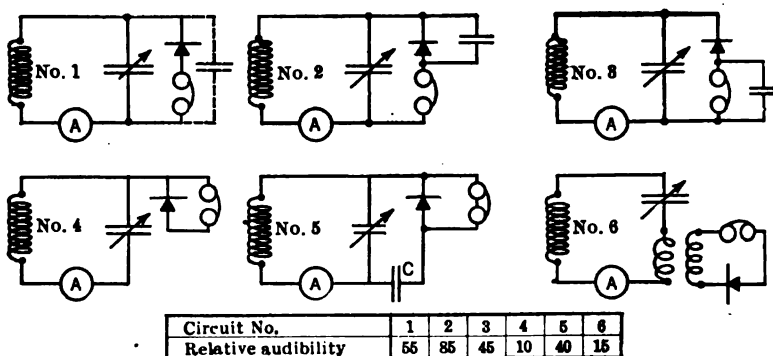

FIG. 4.—Various schemes of connecting crystal rectifier and telephones for indicating resonance in a wave-meter excited by a very low-powered source.

phone circuit. Thus in circuit No. 1, the leads going to detector and phones may possess considerable capacity (as indicated diagrammatically by the dotted condenser), which capacity is in parallel with the wave-meter condenser. The wave-meter calibration will thus no longer apply, since the circuit capacity has been augmented by an uncertain amount, and the determinations are therefore inaccurate. The amount of error produced evidently depends on the relative value of the variable wave-meter capacity, and the external fixed capacity. This error will be a maximum when the variable condenser is set at the minimum value, the meter reading being less than the true wave-length which is being measured. As the variable capacity is increased, the error decreases, and may become negligible at the larger wave-lengths.

With the "unilateral" connection, however, the wave-meter circuit constants are unaltered, regardless of the characteristics of the detector-

¹ Circular of the Bureau of Standards, No. 74, p. 105.

phone circuit, and any pair of phones with associated leads, etc., may be employed. The action of this connection is essentially one of electromagnetic induction. The high-frequency magnetic field linking L links also the closed loop of the phone detector circuit (the coupling is very small, however, and this probably accounts for the low sensibility), and induces in it a radio frequency e.m.f., which will cause rectified radio frequency wave-trains of current to flow in the loop. Electrostatic effects also play a considerable rôle in the operation of this detecting scheme.

The connection has an important application to portable or field-type wave-meters, which may thus be used with phones whose leads vary in length and other characteristics, i.e., size, insulation, and configuration. Since the wave-meter is independent of these variations, accurate determinations can be made, if the audibility requirements do not necessitate coupling the wave-meter too closely to the exciting circuit, while varying degrees of error would occur with connection No. 1, which requires the wave-meter to be used with the phone-detector circuit with which it was calibrated, if accuracy is to be obtained.

Circuit Nos. 2, 3, and 5 all operate through the trapping of a charge on one condenser plate (by means of the rectifier) during the passage of the wave-train, the condenser then discharging through the phones, giving an audible click. Thus in circuit No. 2, if we assume that the detector will permit current to flow downward, but not upward, it is evident that a positive charge will accumulate on the lower condenser plate during the passage of a wave-train. After the group has passed, the condenser discharges downward through the phones (it cannot discharge up through the detector) and up through the inductance of the wave-meter circuit until the charges on its plates are neutralized.

The action of circuit No. 3 is similar to that of circuit No. 1.

In circuit No. 5 the charge is trapped on one plate of the condenser in the phone-detector circuit. If we again assume the detector to be conducting for downward-flowing current, then the right-hand plate of the condenser will accumulate a positive charge. Current will also flow through it in the opposite direction through the phones, but with difficulty due to greater impedance of the phones. The condenser charge, caused by the asymmetrical flow of current, is discharged upward through the phones (it cannot pass through the detector) and causes the phones to click once per wave-train as in previous circuits.

Circuit No. 6 is better suited to large currents, the telephone and detector being replaced with a small hot-wire ammeter, when particularly large currents are to be indicated. If a small power exciting source is supplied to the wave-meter, the energy transferred from the wave-meter circuit to the aperiodic detector circuit is too small to give clearly audible indications, unless the coupling between the exciting circuit and the wave-

meter is increased to an excessive value, which would be undesirable, due to obscurity in the resonance point, and consequent inaccuracy. It possesses the same advantage as circuit 4, in that the wave-meter calibration is nearly independent of the detecting circuit characteristics. These two schemes (No. 4 and No. 6) also possess the advantage that the decrement of the wave-meter, upon which the sharpness of tuning depends, is but little affected by the detector circuit. In the other four arrangements, the decrement is appreciably increased, scheme No. 3 producing the greatest increase (about 300 per cent on the average) while No. 5 produced the least (about 100 per cent on the average).

c. Thermo-couple and Galvanometer.—Very small currents may be indicated by a thermo-couple and sensitive galvanometer. The hot-wire ammeter may also be used, but a limit is reached in this type, however, when the wire becomes so fine as to make the instrument too delicate for practical purposes, and for currents beyond this limit the thermo-couple and galvanometer are generally used.

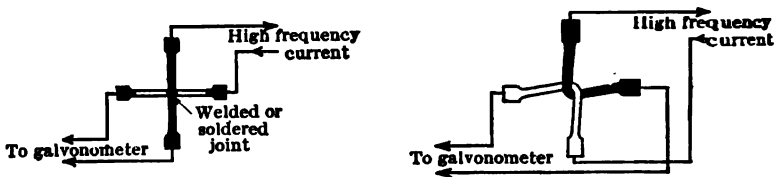

FIG. 5.—Two types of thermo-couples for use with comparatively large currents; the most sensitive couples use an extremely fine welded joint at the contact, and are mounted in a small evacuated glass bulb.

The thermo-couple consists of two crossed wires of dissimilar metals, the two wires being lightly soldered or welded together at the junction point. This junction is connected into the circuit in which the high-frequency current, whose value is to be determined, is flowing, the connection being made as shown in Fig. 5, which illustrates two types of couple in use.

The high-frequency current flowing through the junction raises its temperature, which causes a unidirectional e.m.f. to be generated, which in turn causes a direct current to flow in the galvanometer circuit. This current, and therefore the galvanometer indication, is proportional to the voltage produced, which in turn is proportional to the temperature rise of the junction. The galvanometer deflections are therefore proportional to the square of the high-frequency current.

The sensitivity of the thermo-couple depends on the thermo-electric properties of the wires used and resistance of the junction; if the wires are short, their length has some effect on the sensitivity. The air pressure

also affects the sensitivity as this determines the rise in temperature; the best couples are enclosed in an evacuated glass bulb.

The metals usually used in the couple are constantan and steel, or constantan and manganin, the former metal being a copper-nickel alloy while manganin represents an alloy of copper, manganese, and nickel. The materials are not expensive and their combination possesses perfectly satisfactory thermoelectric properties. A typical constantan-steel thermo element would have wires of about 0.02 mm. in diameter and 4 mm. long. Such an element has a resistance of about 1 ohm and with 15 milliamperes of high-frequency current flowing through, it will generate about 40 micro-volts. The resistance of the galvanometer used with the couple should be approximately the same as that of the couple itself; with such a combination a deflection of 100 mm. would thus be produced on a galvan-

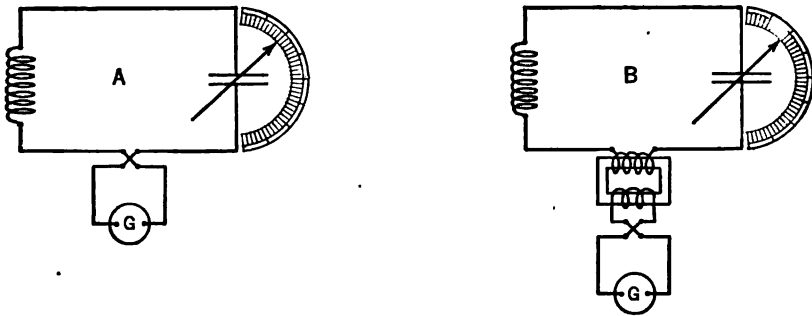

FIG. 6.—The thermo-couple may be connected directly in the wave-meter circuit or may be connected in the secondary of a transformer having suitable ratio.

ometer with a sensitivity of 0.25 mm. per microvolt, by 15 milliamperes of the high-frequency current.

The sensibility of galvanometers used with wave-meters is not as high as this and is not really required, as the high-frequency currents flowing in the circuit may be readily increased by increasing the coupling of the wave-meter to the exciting circuit. Also, the construction of such a sensitive galvanometer would be very delicate, and not applicable for use in connection with the wave-meter, for which it must be of portable construction. The coupling for the thermo-couple and portable galvanometer will in any case be very much less than that required by the direct-reading hot-wire ammeter, and the sharpness of tuning and accuracy thus increased.

Fig 6A illustrates a wave-meter circuit, equipped with thermo-couple and galvanometer. The sensitivity may possibly be increased by using a current transformer, as shown in Fig. 6B. This also increases the effective resistance of the radio frequency circuit, but has the possible

advantage that the galvanometer is not metallically connected to the main circuit. This arrangement has had little application to wave-meter circuits.

d. Crystal Detector and Galvanometer.—This scheme is similar to that indicated in Fig. 4, diagram No. 1, except that a sensitive galvanometer

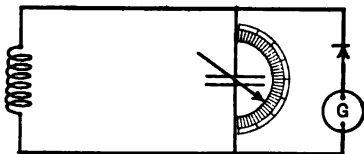

FIG. 7.—In case the resonance curve of the wave-meter is to be plotted, the phones of Fig. 4 may be replaced by a galvanometer; this should be of about the same resistance as the detector, generally several thousand ohms. For suitably low voltages (say less than one volt) the readings of the galvanometer will be proportional to the square of the current in the wave meter circuit.

has been substituted for the phones, the resonant condition thus being visibly indicated. The connections are shown in Fig. 7. This arrangement is equivalent to the thermo-couple-galvanometer scheme discussed above, and possesses the advantage that the increase in effective resistance of the wave-meter, due to it, is less than in the former scheme and the sharpness of tuning is therefore better. It possesses the disadvantage, however, of requiring an external shunt connection to be made across the variable condenser, decreasing the accuracy of the instru-

ment, as has already been discussed for the similar circuit using phones.

The galvanometer indications will be proportional to the mean current (or d.c. component) flowing through it. For large a.c. voltages the currents may be proportional to the voltage, while they are proportional to higher powers of the voltage at very low voltages in fact, proportional to the square of the voltage when it is sufficiently low. This is indicated by the curves in Fig. 60, page 347.

e. Neon Tube.—This indicator depends on the luminous effect which occurs, when the electric potential impressed on a gas at low pressure is increased to a value where cumulative ionization (by impact) occurs. The connections of the tube are indicated in Fig. 8.

As the wave-meter circuit approaches resonance, the drop across the condenser and tube increases, and at resonance become a maximum, under which condition the tube glows at maximum brilliancy. This scheme is simple and determinations are quickly and easily made. The accuracy obtainable, however, is not so good as with the previous circuits, as it is difficult to judge exactly the point of maximum brightness, especially if

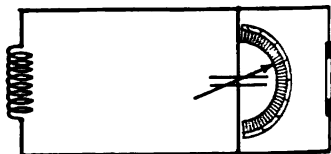

FIG. 8.—When the wave-meter is used in testing a high-powered circuit and a resonance indicator (as contrasted to a measuring device) only is required, a small glass tube filled with a rarefied gas, such as neon, is applicable.

small powers are involved, in which case close coupling may be required to cause the tube to glow, still further decreasing the accuracy of the measurement. Actually this scheme is good only for testing on high-power sets; a buzzer-excited circuit would not produce sufficient current in the wave-meter to make the tube glow, no matter how tight the coupling.

f. Incandescent Lamp.—This device, in its manner of indicating resonance, is similar to the neon tube discussed above. It is, however, connected directly in series in the wave-meter circuit, as indicated in the diagram of connections (Fig. 9). The lamp is a low voltage lamp (2- or 4-volt battery lamp) and is usually connected into the circuit by means of an ordinary small lamp socket, which is short-circuited when the lamp is not in use.

This scheme possesses the same advantages and disadvantages which were mentioned in connection with the neon tube. It also possesses the disadvantages of inserting a considerable additional resistance in the wave-meter circuit, while the neon tube arrangement has the disadvantage of connecting a leakage

of uncertain value across the wave-meter condenser, as discussed before in connection with previous circuits. The effect of the parallel connection of the neon tube is of course to raise the effective series resistance of the wave-meter circuit somewhat, the amount of increase depending upon the intensity of glow in the tube. There is little to choose between the lamp and tube.

Classification of Resonance Indicators.—The above schemes for indicating resonance of the wave-meter circuit may be classified as to whether the results obtained are quantitative or qualitative, and the power of the circuit to which the wave-meter is coupled. Those schemes which permit a curve of high-frequency current (or indication proportional thereto) to be plotted against the wave-length readings on the wave-meter condenser, are considered as quantitative, while those which permit only the resonant wave-length adjustment to be obtained, are considered qualitative.

Those schemes which indicate visibly are, in general, in the quantitative class. The neon tube and incandescent lamp are exceptions to this rule, and are in the qualitative class. The hot-wire ammeter, the thermocouple and d.c. galvanometer, and crystal and galvanometer, are arrangements which will give quantitative results. Audible schemes are usually qualitative, as illustrated by the crystal and phones. It should be noted that this device may be made quantitative by shunting the phones with a variable resistance, as in the audibility meter, but the results obtained are not accurate. It is also possible to obtain quantitative measurements

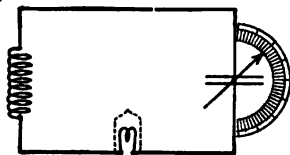

FIG. 9.—In some wave-meters a small, low resistance, incandescent lamp has been used as resonance indicator.

by varying the coupling between the wave-meter and exciting circuit, so as to keep the note heard in the phones at a fixed loudness as the wave-meter condenser is varied. This method is also inaccurate and is seldom used.

The hot-wire ammeter, thermo-couple and galvanometer, neon tube and incandescent lamp are employed where the current in the exciting circuit is of considerable magnitude, as in the case of a transmitting set. For measurements of low power circuits, i.e., receiving circuits, the detector and phone arrangement is the most important, and is used exclusively when quantitative results are not required. The detector and sensitive galvanometer are used when quantitative data are to be obtained.

Use of Special Condenser to Make Wave-meter Scale Uniform.—Since,

$$\lambda_{\text{meters}} = 1885\sqrt{L_{\mu h}C_{\mu f}},$$

the subscripts indicating micro units, where L is usually fixed in value (or variable in fixed steps only) this equation may be re-written as follows:

$$\lambda_{\text{meters}} = 1885\sqrt{aC},$$

or

$$\lambda_{\text{meters}} = K\sqrt{C}, \text{ where } K = 1885\sqrt{a}.$$

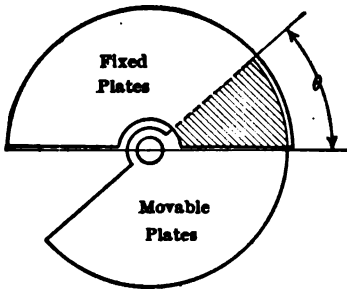

FIG. 10.—With circular plates the capacity of the condenser is nearly proportional to the angle through which the movable plates are rotated.

In the usual type of variable condenser the movable element consists of semicircular plates which may be rotated, so that more or less of their area intersects the area of the fixed element, as shown in Fig. 10.

Since the capacity is proportional to the amount of superimposed areas, which in turn vary directly with the angle of rotation the capacity varies with the angle of rotation, i.e.,

$$C = k\theta,$$

and since

$$\lambda = K\sqrt{C},$$

it follows

$$\lambda = K\sqrt{k\theta} = K'\sqrt{\theta}. \quad \dots \dots \dots (1)$$

Thus if the condenser scale were graduated to read directly in wave-lengths instead of the capacity value, such scale would be crowded at the smaller wave-lengths and opened up at the higher values, which would tend to make the readings difficult and increasingly inaccurate at the

lower wave-length values. These conditions are graphically illustrated in Fig. 11.

The wave-length curve indicates the rapid variation of wave-length with capacity (C) at the smaller capacity values (necessitating a crowded scale), and the very gradual change at the larger values (necessitating an open scale). This variation is uneconomical of space and undesirable because of the probable error it may introduce.

It may be desirable to design the shape of the movable condenser element so that the wave-length shall vary directly with the angle of rotation, i.e.,

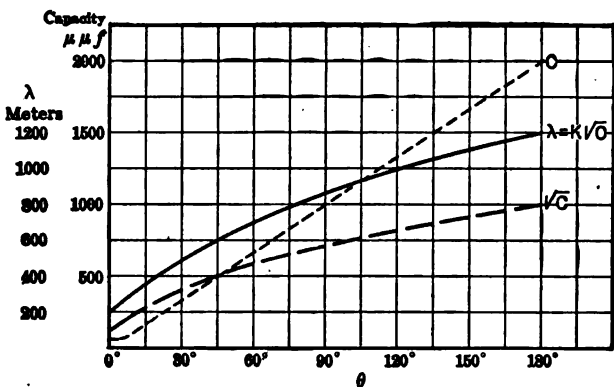

FIG. 11.—A condenser such as that pictured in Fig. 10 will, if used in a wave-meter, give a wave-length calibration scale crowded at the shorter wave-lengths and opening out at the longer wave-lengths.

$$\lambda = k\theta,$$

and the wave-length scale be uniform throughout its length. The required form of the moving condenser plates to produce this relationship may be readily derived as follows:

since

$$\lambda = K\sqrt{C} = k\theta,$$

$$\sqrt{C} = K'\theta \text{ where } K' = \frac{k}{K},$$

or,

$$C = a\theta^2 \text{ where } a = (K')^2.$$

The capacity is also proportional to the area intersected by the movable and fixed elements; this area is expressed by:

$$A = \frac{1}{2} \int r^2 d\theta \text{ (in polar coordinates).} \quad \dots (2)$$

Now since

$$C = K'' A = a\theta^2,$$

we have,

$$A = \frac{C}{K''} = \frac{a\theta^2}{K''} = b\theta^2, \quad \dots \dots \dots (3)$$

where

$$b = \frac{a}{K'''}.$$

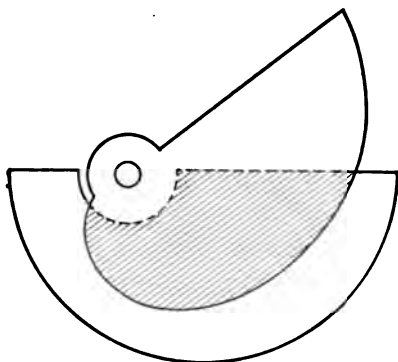

Fig. 12.—By suitably forming the rotating plates and locating the shaft eccentrically the capacity of the condenser may be made to vary as the square of the angle of rotation.

rotation is relatively small at the smaller values of capacity, thus tending to spread the wave-length scale. At the higher values of capacity, the capacity variation per degree rotation, is large, and tends to make the scale close up. Actually, the capacity varies as the square of the deflection and the wave-length scale is uniform over the entire range. These conditions are indicated in Fig. 13.

To provide clearance for the shaft of this moving-plate system a circular area must be cut from the fixed plates. If this is to be taken into account, the equation of the boundary curve of the movable plates must be corrected as follows (assuming the radius of circular area cut from stationary plates equal to r_2):

$$A = \frac{1}{2} \int r^2 d\theta - \frac{1}{2} \int r_2^2 d\theta$$

Differentiating expressions (2) and (3) with respect to θ and equating we obtain

$$\frac{dA}{d\theta} = \frac{1}{2} r^2 = 2b\theta,$$

or,

$$r^2 = 4b\theta,$$

and

$$r = \sqrt{4b\theta} = 2\sqrt{b\theta}. \quad (4)$$

Fig. 12 illustrates the form of the movable plates when designed according to this expression, the fixed element being usually made semicircular for convenience.

It will be seen from the figure that the capacity variation per degree

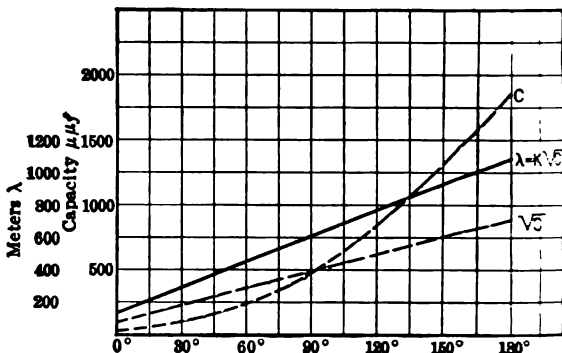

Fig. 13.—With a condenser of the form shown in Fig. 12 the capacity varying as the square of the angle of rotation, the wave-length calibration scale is uniform.

rotation is relatively small at the smaller values of capacity, thus tending to spread the wave-length scale. At the higher values of capacity, the capacity variation per degree rotation, is large, and tends to make the scale close up. Actually, the capacity varies as the square of the deflection and the wave-length scale is uniform over the entire range. These conditions are indicated in Fig. 13.

$$= \frac{1}{2} \int (r^2 - r_2^2) d\theta,$$

then

$$\frac{dA}{d\theta} = \frac{1}{2}(r^2 - r_2^2) = 2b\theta,$$

or

$$r = \sqrt{4b\theta + r_2^2}. \dots \dots \dots (5)$$

This is the form of condenser used in modern wave-meters, having practically superseded the semicircular form, due to its greater convenience and accuracy of reading.

A simpler form, utilizing rectangular plates, but not having commercial application, due to space requirements, is shown in Fig. 14.

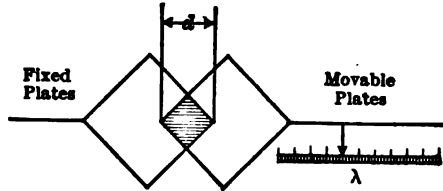

FIG. 14.—A simple form of condenser in which the capacity varies as the square of the setting of the movable plates.

It is readily seen that the intersected area of the fixed and movable elements (and thus the capacity) varies as the square of the distance of movement. Thus the wave-length scale, placed as shown, would have a uniform marking,

as in the case of the rotating plate condenser previously described.

Autodyne Wave-meter.—It has been previously shown, in the description of the "beat" method of receiving undamped waves (see page 514), that the beat frequency reduces to zero when the incoming and local high-frequencies are made equal. Therefore if the local high frequency is known, the incoming frequency is at once determined. This principle is utilized in the so-called autodyne wave-meter illustrated in Fig. 15.

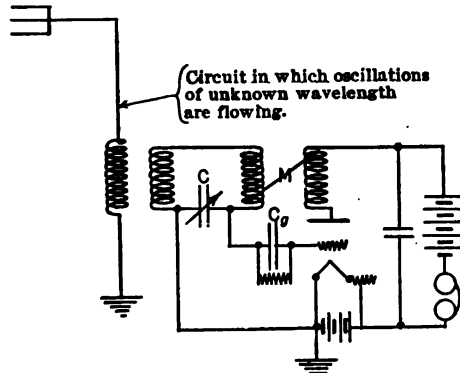

FIG. 15.—If an oscillating tube circuit (calibrated for frequency or wave-length of the closed oscillating circuit) is available it may be used as a autodyne wave-meter; when the beat note (heard in the phones) is reduced to zero, the unknown wave-length is the same as that given by the calibration curve of the oscillating tube.

his calibration must be frequently checked as the constants of the tube change with time. It will be noted that the capacity of the tube from

grid to ground (assuming C_g omitted) is in parallel with C , and this capacity will therefore effect the wave-length of the local oscillations. It has been shown (see page, 432) that

$$C_{\text{grid to ground}} = C_{\text{grid to filament}} + (\mu + 1)C_{\text{grid to plate}}$$

also that μ is changed somewhat when the filament current or plate voltage is changed. Indirectly, therefore, a change in filament current or plate voltage causes a change in the frequency (or wave-length) of the oscillations.

To limit this change of frequency with filament current or plate voltage the grid condenser C_g is inserted in the circuit. C_g being small compared to C_{g-g} (the capacity from grid to ground), and fixed in value, the capacity in shunt across C is practically constant. The total capacity of the oscillating circuit is thus made more nearly independent of C_{g-g} , and the generated frequency thus also made constant and independent of variations in filament current or plate voltage. It is also desirable that the moving element of condenser C should be on the ground side. (See page 635.)

If this wave-meter is used to measure the frequency of an oscillating tube generator, producing upper harmonics in addition to its fundamental, there exists the possibility of an upper harmonic frequency, instead of the fundamental frequency, being measured. This should be avoided by making careful determinations over the entire range of possible values, particularly at the low wave-lengths. The note obtained when the wave-meter is set to the fundamental is much stronger than that obtained with the upper harmonics, which are relatively weak. In fact, they are so weak that this error can only be made when the wave-meter is close to the source of power. At greater distances, only the fundamental will have sufficient power to give an audible note in the wave-meter phones.

Actual Method for Measuring the Wave-length of a Transmitting Set.—The set is first carefully adjusted as for normal operation and the wave-meter then very loosely coupled to the antenna circuit. It is very important that the meter be coupled to a portion of the antenna circuit, where the fluxes set up are truly representative of the high-frequency current flowing. As has already been mentioned in Chapter V, page 330, the complex resultant flux which links the oscillation transformer does not fulfill this requirement and the wave-meter is therefore always coupled to a portion of the circuit remote from the oscillation transformer. It may be coupled to the loading inductance if this is connected in the circuit. It is customary, however, since this loading inductance may not be in service, to insert in the circuit a small inductance of one or two turns only, to which the wave-meter may be conveniently coupled. This coil has an inductance which is negligible in value compared to the total

inductance of the circuit, and hence will not appreciably affect the characteristics of the set. This coil may be arranged for mounting directly on the wave-meter, one terminal being connected to ground, while the other is connected to the antenna through the oscillation transformer.

The coupling between the small inserted inductance, called a search coil, and the wave-meter itself, must always be as loose as possible and yet permit definite indications to be obtained. This is so that the current in the wave-meter may not produce an appreciable reaction back on the circuit whose wave-length is being measured, which would cause its own indications to be in error. This is similar to the case of instruments which are used to measure pressure: a voltmeter must draw so little current as to alter inappreciably the electrical pressure at the points to which it is connected, or a gauge, inserted in a gas tank, must not have so much

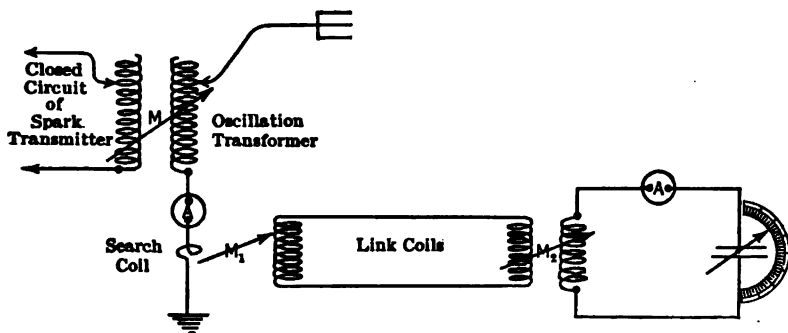

FIG. 16.—In measuring the wave-length of a transmitting set, a search coil (generally one turn) is inserted in the base of the antenna, and the wave meter coupled *very loosely*, to the search coil. The Marconi Co. has used an additional "link" circuit to permit easy adjustment of coupling.

space within itself, as to decrease materially the pressure of the gas which it is supposed to measure.

The simplest manner of varying the coupling is to vary the distance between the wave-meter and the search coil. An intermediate circuit whose coupling to the wave-meter and search coil may be conveniently varied is also largely employed. This arrangement is shown in Fig. 16, and is used by the Marconi Company in their station type wave-meter.

It is very important that very loose coupling be employed when making the initial adjustment of the wave-meter, as otherwise the delicate hot-wire ammeter may be burned out when the resonant adjustment is attained. The coupling may easily be increased when it is found that the value used gives deflections which are too small for accuracy. The best adjustment is that which results in definite, readable indication with minimum coupling.

When the preliminary adjusting of the wave-meter indicates this condition, the adjustment of the set should be carefully repeated, and wave-

length readings taken at each position of maximum current. If the coupling between the antenna and closed circuits is small, but one such point will be obtained, indicating that the energy is concentrated more or less into the one wave-length. If the coupling were increased, two such points would be obtained, the corresponding wave-length readings indicating the length of the "coupling waves" which now exist simultaneously in the circuits. Where a partial quenching action is obtained, three such points may appear, the corresponding wave-length readings representing the fundamental wave-length, at which most energy is radiated, after the quenching action has occurred, and the two coupling waves, at which most energy is radiated before the quenching action takes place.

The above covers specifically a spark transmitter, but the procedure with an undamped wave set is exactly similar. In this case only one point of maximum current will be obtained, and this point will be very sharp and clearly defined, as the energy is radiated at one wave-length only (neglecting upper harmonics), which is fixed by the speed of the generator (Alexanderson, Goldschmidt), or the circuit constants (Poulson arc and vacuum tube).

If, however, the wave-meter be coupled too tightly to a low-powered circuit of the latter type, e.g., an oscillating-tube generator, the reaction of the wave-meter circuit current on the tube circuit will cause the frequency of the tube circuit to change. It may raise or lower the frequency of the tube circuit, depending upon its setting. This condition is evidently undesirable, and the coupling should be reduced until the reaction of the wave-meter on the tube circuit becomes negligible. If the hot-wire ammeter is not sufficiently sensitive to indicate accurately under this condition, it should be replaced by one of the more sensitive type of visible indicators, e.g., thermo-couple and galvanometer.

The antenna ammeter may also be used as the wave-meter indicating device when measuring the wave-lengths of a tube set. Thus assuming the connections shown in Fig. 16 (spark transmitter replaced with a tube generator), as the wave-meter adjustment reaches the resonant value the wave-meter current increases suddenly (although this increase may be too small to deflect the wave-meter hot-wire ammeter), and the losses in the wave-meter become a maximum. Since these losses are supplied from the antenna, this amounts to a sudden increase in the antenna resistance, and the antenna current will therefore suddenly decrease, this decrease being indicated by the antenna ammeter. Thus, this dip in antenna current is an indication that the wave-meter is in resonant adjustment and the wave-length of the set is therefore determined.

Energy Distribution of a Set from a Wave-meter.—In addition to determining the wave-length of the set, i.e., the wave-length at which maximum energy is radiated, the wave-meter may also be used to deter-

mine the distribution of *all* the energy radiated by the set. The procedure is exactly similar to the foregoing, with the exception that instead of noting only the wave-length readings at points of maximum current, readings are taken, at a number of condenser settings, of both the wave-length and the wave-meter current or "current squared" if the hot-wire ammeter scale has been calibrated in this way.

Referring to Fig. 16, as the variable condenser is adjusted to the several wave-lengths in succession, the current in the ammeter will successively increase as the resonant adjustment is approached, and then decrease as

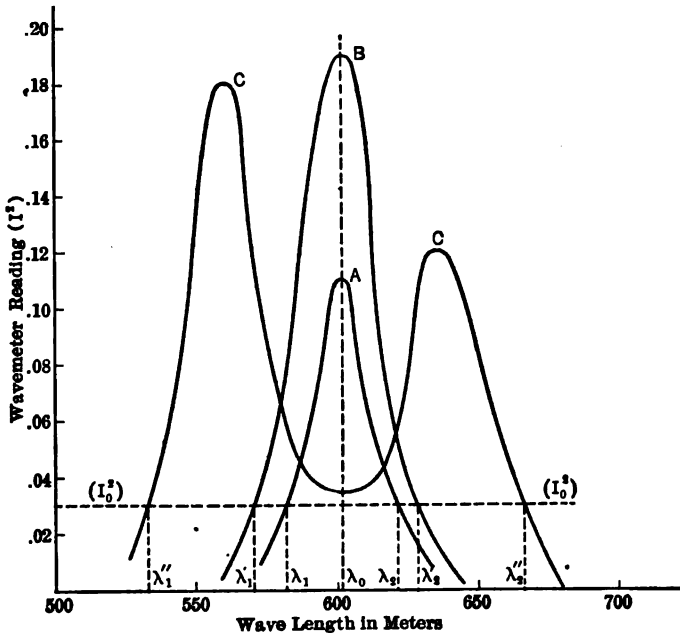

FIG. 17.—Energy distribution curves of a spark transmitter, with three different coupling values used in the oscillation transformer.

the adjustment again departs farther and farther from that of resonance. If the coupling M between the antenna and closed circuits is loose the curve plotted between the ammeter and condenser scale (λ) readings will have the form shown in Fig. 17 (A)¹.

As the coupling M is tightened, the energy radiated at λ_0 , the wave-length for which the set has been adjusted increases, as shown in curve B, but further increase of coupling causes the formation of the coupling waves and a spreading of the energy as shown in curve C. These curves

¹ These curves are the same as those shown in Fig. 46, p. 332, and are here reproduced for convenience.

have already been briefly discussed in Chapter V (see page 326), and are called the "energy-distribution" curves, since they show the amount of energy radiated at the different wave-lengths.

Significance of Energy Distribution Curve.—Considering the wave-meter simply as a calibrated receiving circuit having a very small decrement, the curves indicate proportionately the amount of energy which would be received (and therefore the strength of signal), by each one of a number of such receiving circuits assumed equidistant from the transmitting station, and each tuned to a different wave-length. Thus, that circuit which is tuned to λ_0 (assuming M to be loose or medium coupling) would receive a maximum amount of energy and the strongest signal. This would be the station for which the signal is intended. The other receiving stations would also receive some energy; this energy would decrease, as the adjustment from λ_0 becomes greater and greater, and signals so received, represent interference to the receiving station. If we consider I_0^2 as the energy required for audibility at the several stations, then λ_1 to λ_2 represents the range of tuning over which interference will occur if the transmitter coupling M is loose. Similarly, λ'_1 to λ'_2 , and λ''_1 to λ''_2 represent the range of wave-lengths over which interference occurs as the coupling is tightened. It is therefore evident that tight coupling should be avoided except under emergency conditions (S O S call), so that interference to other receiving stations, which may be tuned to wave-lengths in the neighborhood of λ_0 , be minimized.

It should be kept clearly in mind that the set is radiating energy at all the different wave-lengths, and *each* receiving station is *in tune with the energy* which is causing the signal to be heard. That is, each receiving circuit picks out its own particular wave-length to which it is tuned, and its received signal is proportional to the amount of energy which the transmitter is sending out at that wave-length.

Wave-meter Coupling.—When determining the energy distribution curves for the set, the coupling between the wave-meter and search coil should first be adjusted so that a full scale deflection is obtained on the hot-wire ammeter when the resonant condition is obtained with the transmitter coupling (M , Fig. 16) adjusted to its proper value. This coupling between the wave-meter and search coil should remain undisturbed throughout the determination of the several energy distribution curves. The curves obtained will thus have maximum permissible ordinate values, making any error in their determination a minimum, and the energy radiation under the different coupling adjustments will be comparative in a quantitative as well as a qualitative sense.

Energy Distribution for Undamped Wave-transmitter.—For an undamped wave-transmitter, the energy is all radiated at the fundamental wave-length, neglecting the small amount radiated by the upper harmonics.

which are relatively weak. If the wave-meter circuit had zero decrement, that is, no resistance, the signal would be received by that wave-meter only, which is tuned to λ_0 . The energy distribution curve in this ideal case would be a straight line ordinate at λ_0 (Fig. 18).

Since the wave meter always possesses a decrement, however small, the distribution curve will appear as shown by the curve A, Fig. 18. The greatly decreased interference is indicated by the small difference between λ_1 and λ_2 . Assuming receiving circuits with a decrement equal to that of the wave-meter only those tuned within this range would receive interference, while the set for which the signal is intended receives a stronger

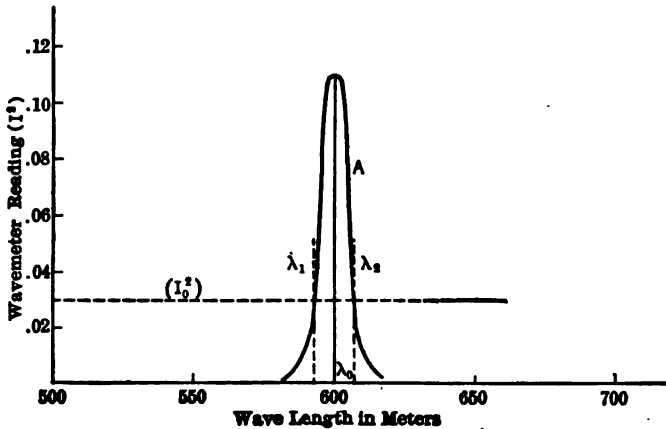

FIG. 18.—The energy distribution curve obtained from an undamped wave transmitter is very narrow, being determined entirely by the decrement of the wave-meter itself; if the wave-meter had zero decrement the energy distribution curve obtained would be a straight vertical line.

signal, due to all the energy being radiated by the transmitter at the wave-length (λ_0) for which the wave-meter is tuned. The greater selectivity and efficiency of the undamped wave-set, as indicated by the above characteristics, are rapidly causing its increasing use in the art, and it may eventually supersede the damped wave-set altogether.

Determination of Decrement of a Spark Transmitter from Energy Distribution Curve and Known Decrement of the Wave-meter.—If we consider a wave-meter circuit coupled loosely to an undamped wave-generator as shown in Fig. 19, then, when the wave-meter circuit is tuned to resonance, its reactance $(L\omega - \frac{1}{C_r\omega})$ is equal to zero and the current is limited only by the resistance in the circuit, or

$$I_r = \frac{E}{R}$$

where E is the voltage induced in the wave-meter circuit. Now, if the condenser adjustment be altered from its resonant value C_r , the reactance in the circuit is no longer equal to zero, that is,

$$L\omega - \frac{l}{C\omega} \neq 0.$$

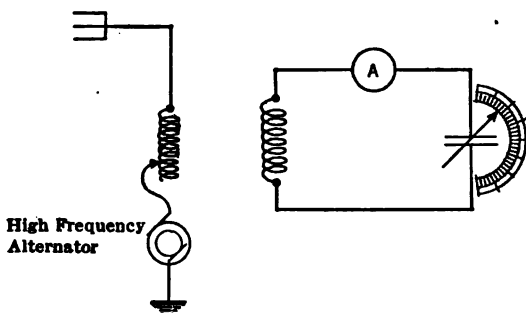

FIG. 19.—Connection of wave-meter to a source of continuous waves for determination of the decrement of the wave-meter itself. Conditions must be so adjusted that as the wave-meter setting is changed the current in the power circuit shows no change.

Since $L\omega = \frac{1}{C_r\omega}$, this reactance may be expressed as,

$$\frac{1}{C_r\omega} - \frac{1}{C\omega} \neq 0,$$

and the current is

$$I = \frac{E}{\sqrt{R^2 + \left(\frac{1}{C_r\omega} - \frac{1}{C\omega}\right)^2}} = \frac{E}{\sqrt{R^2 + \frac{1}{C_r^2\omega^2} \left(\frac{C_r - C}{C}\right)^2}} \quad (6)$$

It may be shown¹ that the decrement is expressed by,

$$\delta = \pi RC_r\omega$$

or,

$$\frac{1}{C_r\omega} = \frac{\pi R}{\delta}$$

¹ From Formula (20), page 214, we have $\delta = \frac{R}{2fL}$,

since $f = \frac{\omega}{2\pi}$, $\delta = \frac{R}{2\omega L} = \frac{\pi R}{\omega L}$,

also $\omega L = \frac{1}{\omega C_r}$, therefore $\delta = \pi RC_r\omega$

Substituting this expression in the above expression for current, we have

$$I = \frac{E}{\sqrt{R^2 + \frac{\pi^2 R^2}{\delta^2} \left(\frac{C_r - C}{C}\right)^2}} \dots \dots \dots (7)$$

and

$$\frac{I_r^2}{I^2} = \frac{\frac{E^2}{R^2}}{\frac{E^2}{R^2 + \frac{\pi^2 R^2}{\delta^2} \left(\frac{C_r - C}{C}\right)^2}} = \frac{R^2 + \frac{\pi^2 R^2}{\delta^2} \left(\frac{C_r - C}{C}\right)^2}{R^2} = 1 + \frac{\pi^2}{\delta^2} \left(\frac{C_r - C}{C}\right)^2$$

Solving this expression, we obtain

$$\delta = \pi \frac{C_r - C}{C} \sqrt{\frac{I^2}{I_r^2 - I^2}} \dots \dots \dots (8)$$

The value of δ so obtained is the decrement of the wave-meter itself. This will be referred to again later in the discussion of wave-meter decrement and its measurement.

For an exciting source, the oscillations of which are damped, e.g., a spark transmitter, it has been shown ¹ that a derivation such as that given above yields an expression which gives the sum of the decrements of the impressed voltage and of the wave-meter itself; that is, we have

$$\delta_1 + \delta_2 = \pi \frac{C_r - C}{C} \sqrt{\frac{I^2}{I_r^2 - I^2}}$$

where δ_1 = the decrement of the circuit under measurement;
 δ_2 = the decrement of the wave-meter circuit.

This formula is sufficiently accurate for all practical purposes, if

1. $\delta_1 + \delta_2$ is small compared to 2π .
2. $\frac{C_r - C}{C}$ is small compared to unity.
3. If the wave-meter is loosely coupled to the wave-meter circuit.

The procedure for determining δ_1 , assuming δ_2 known, may be outlined as follows:

1. An energy distribution curve is obtained as shown in Fig. 20. (Coupling between the closed circuit and the antenna circuit of the transmitting set assumed to be loose.)

2. The value of C_r is then determined from this curve. The value of

¹ See Chapter IV, page 272.

C is preferably obtained for that point of the curve where $I^2 = \frac{I_r^2}{2}$, since then

$$\sqrt{\frac{I^2}{I_r^2 - I^2}} = 1,$$

and the calculation becomes simpler.

3. Knowing C_r and C_1 , as obtained from the curve, and substituting in the equation

$$\delta_1 + \delta_2 = \pi \frac{C_r - C_1}{C_1}, \dots \dots \dots (8a)$$

the value of $\delta_1 + \delta_2$ is readily obtained, from which the known decrement δ_2 of the wave-meter is subtracted to determine the unknown decrement.

It is evident that two values of capacity, one greater and one less than the resonant value; will cause I^2 to become equal to $\frac{I_r^2}{2}$, as indicated in Fig. 20. Therefore, the following expression may also be used:

$$\delta_1 + \delta_2 = \pi \frac{C_2 - C_r}{C_2} \sqrt{\frac{I^2}{I_r^2 - I^2}} \dots \dots \dots (8b)$$

Since the energy distribution curve is never quite symmetrical, the value of δ_1 as determined by the two expressions using C_1 or C_2 , will be slightly different. It is therefore desirable to average the results directly, using the expression

$$\delta_1 + \delta_2 = \pi \frac{C_2 - C_1}{C_2 + C_1} \sqrt{\frac{I^2}{I_r^2 - I^2}} \dots \dots \dots (9)$$

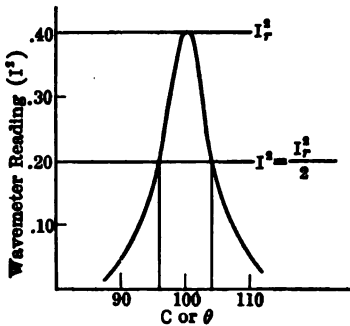

FIG. 20.—In getting decrement from the energy distribution curve the values of capacity are determined for those two points (above and below resonance) which reduced the wave-meter (current)² to one-half its maximum value as well as the capacity required for resonance.

This expression does not involve a measurement of C_r , which is usually more difficult to determine accurately, due to the resonance curve being flat at that point, than either C_2 or C_1 , which are read at a point where I^2 is varying rapidly with capacity. This expression is therefore usually employed in preference to those involving C_r . (Equations (8), (8a), and (8b).)

As an illustration, referring to Fig 20, assume that the coupling between the wave-meter and the search coil has been adjusted, so the wave-meter at resonance reads .40 (I_r^2) at resonance. The capacity is then decreased until the ammeter reads .20 (I^2) and the value of C_1

noted as 96.0. It is immaterial what units the condenser scale reads—whether actual capacity or simply degrees rotation,¹ if the ordinary semi-circular plate condenser is used, as has been assumed in this problem.

The condenser value is then increased through the resonant value to C_2 , at which point the ammeter again reads $I^2 = .20$ and C_2 is noted as 104.

Substituting in Eq. (9) we have,

$$\delta_1 + \delta_2 = \pi \frac{104 - 96.0}{200} = \frac{\pi \times 8}{200} = .125$$

Assuming $\delta_2 = .040$ (this may be obtained from the calibration curves of the instrument or determined as described below), we obtain $\delta_1 = .085$.

If the scale is graduated in wave-lengths and wave-length values are read, the following expression should be used,

$$\delta_1 + \delta_2 = \pi \frac{\lambda_2^2 - \lambda_1^2}{\lambda_2^2 + \lambda_1^2} \sqrt{\frac{I^2}{I_1^2 - I^2}} \dots \dots \dots (10)$$

since $\lambda = K\sqrt{C}$ and $\lambda^2 = K'C$.

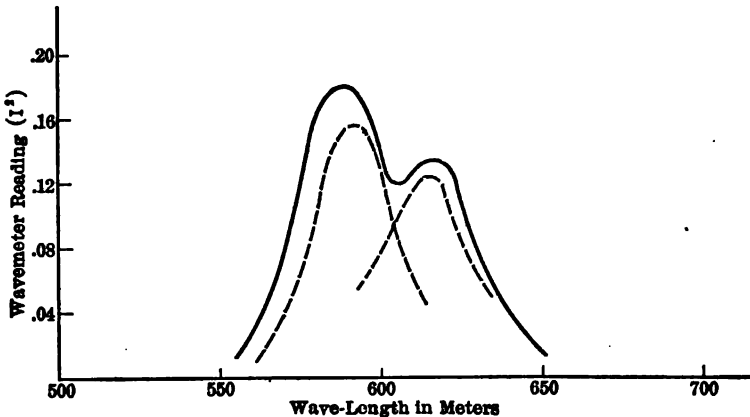

FIG. 21.—If the coupling of the oscillation transformer is too tight a double-humped resonance curve is obtained from the wave-meter reading; the resonance curve for each of the component frequencies of the curves may be obtained by the scheme shown in Fig. 22.

If the coupling of the set is increased to some considerably higher value, a double-peaked energy distribution curve is obtained, due to the separate points of resonance for the two coupling waves. If this curve has well

¹ This statement assumes that the condenser capacity is zero at zero scale setting. In case the amount of capacity with zero setting is appreciable, compared to the actual capacity used, a suitable correction must be made, if the setting of the condenser, instead of actual capacity, is used in the calculation.

separated peaks, as shown in Fig. 17, curve *C*, the decrement of each oscillation may be determined from the two peaks by the method outlined above for the one-peaked curve. The curve may, however, have the appearance illustrated in Fig. 21, in which case this procedure cannot be followed, since both oscillations are simultaneously effective in the wave-meter.

The decrement of each oscillation may then be determined by coupling the wave-meter to the primary and secondary circuits of the set, as shown in Fig. 22.

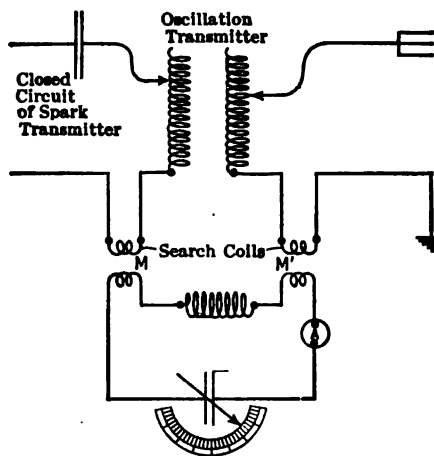

FIG. 22.—By suitably coupling the wave-meter to both closed circuit and antenna of the transmitting set, a resonance curve may be obtained for each of the two frequencies generated by the set.

The higher-frequency currents in the primary and secondary circuits are out of phase approximately 180° and by proper adjustments of the coupling M and M' , these oscillations may be neutralized in the wave-meter circuit. The decrement of the lower-frequency oscillations may then be determined as previously described, after which, one of the coupling coils may be reversed, and the lower-frequency oscillations (which are in phase in the primary and secondary circuits of the set) be thus neutralized and the decrement of the high-frequency oscillations similarly

determined. The energy distribution curves determined for each oscillation will appear somewhat as indicated by the dotted curves in Fig. 21.

Determination of Wave-meter Decrement Using an Undamped Wave Source.—It has already been indicated how the decrement δ_2 of the wave-meter may be obtained by exciting the instrument from an undamped wave-source. In this case,

$$\delta_1 + \delta_2 = \pi \frac{C_2 - C_1}{C_2 + C_1},$$

becomes,

$$\delta_2 = \pi \frac{C_2 - C_1}{C_2 + C_1} = \text{decrement of wave-meter}$$

since,

$$\delta_1 = 0.$$

This measurement may conveniently be made by any one of the several generators of high-frequency continuous oscillations described in

Chapter VII. The high-powered tube circuit is preferable for this purpose, due to the frequency being fixed, and the exciting circuit being of sufficient power to be unaffected by the proximity of the wave-meter circuit. However, in case the tube is not oscillating powerfully, the oscillations may be affected when the wave-meter is coupled to the circuit. To prevent this, it is desirable to use very weak coupling and have an ammeter in the circuit supplying power to the wave-meter circuit. The indication of this meter should remain constant throughout the decrement determination showing that the power generated by the tube was not appreciably affected by the wave-meter tuning.

The wave-meter coupling, if made too great, may also affect the frequency of the tube oscillations as well as their amplitude. The effect of this frequency variation on the decrement determination may be analyzed with the help of Fig. 23.

If the capacity of the wave-meter condenser is less than that required for resonance, then a current will flow in the wave-meter circuit which is leading with respect to the induced e.m.f. The effect of this leading current on the tube circuit is to increase the apparent inductance, causing the wave-meter indication to correspond to a point on the resonance curve of a circuit whose resonant frequency is below that given by C_r . Similarly, a lagging current in the wave-meter circuit (wave-meter capacity greater than resonance value) decreases the apparent inductance, the wave-meter indication corresponding to a point on a resonance curve, the resonant frequency of which is above that given by C_r . These effects have

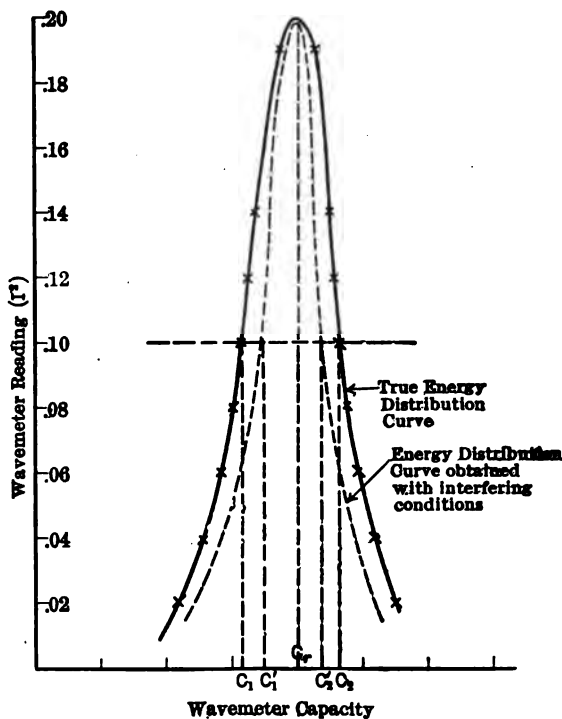

FIG. 23.—If the wave-meter is coupled too tightly (to a low-powered set) the energy distribution curve will be unreliable because of the reactions of the wave-meter on the power circuit.

been mathematically derived in Chapter I, as expressed by Eq. (85, page 91.

The result of this action, as indicated in Fig. 23, is to squeeze the apparent energy distribution curve together. The observed decrement may therefore be quite inaccurate, and will always be less than the true value. This effect should be guarded against by decreasing the coupling to as small a value as possible.

Determination of Wave-meter Decrement Using Impulse Excitation.—Although the above method represents the most direct and simple means for determining δ_2 , undamped wave-generators may not always be available, in which case impulse excitation may be employed. In its ideal application, the condenser of the instrument would first be charged to a given potential, and allowed to discharge through the circuit. A known resistance is then inserted in the wave-meter circuit and the condenser again charged to the same potential as before and permitted to discharge. In both cases the energy dissipated in the circuit is

$$\frac{1}{2}CE^2 = I_1^2R = I_2^2(R + \Delta R),$$

from which

$$R = \Delta R \frac{I^2}{I_1^2 - I_2^2}, \dots \dots \dots (11)$$

where R is the resistance of the wave-meter circuit and ΔR the inserted resistance. I_2^2 and I_1^2 represent, respectively, the reading of the wave-meter ammeter, with and without inserted resistance, these readings being proportional to the square of the wave-meter current. Knowing the capacity C and inductance L of the wave-meter, the decrement is readily obtained from the relations:

$$\delta_2 = \pi RC\omega = \pi \frac{R}{L\omega} = \pi R \sqrt{\frac{C}{L}},$$

for any wave-length.

The above ideal case is approximated closely by some form of impulse excitation, for which a spark transmitting set, equipped with a suitable quenched gap (such as is used in spark transmitters operating on impulse excitation) and with the antenna circuit open, may be conveniently utilized as an impulse generator. The procedure is similar to that described above, but the energy is not exactly equal for the two conditions of different resistance, and a constant K is therefore introduced in the energy expression as follows:

$$I_1^2R = KI_2^2(R + \Delta R)$$

$$R = \Delta R \frac{KI_2^2}{I_1^2 - KI_2^2} \dots \dots \dots (12)$$

It has been shown ¹ that

$$K = 1 + \frac{\Delta\delta}{\delta_1 + \delta_2},$$

where δ_1 is the decrement of the exciting circuit;
 δ_2 is the decrement of the instrument circuit;
 $\Delta\delta$ is the additional decrement due to inserting ΔR in the wave-meter circuit.

For impulse excitation δ_1 is very large compared to δ_2 and K is essentially equal to unity; therefore

$$R = \Delta R \frac{I_2^2}{I_1^2 - I_2^2} \text{ as before.}$$

If resistance is inserted in the circuit until $I_2^2 = \frac{1}{2}I_1^2$, then

$$R = \Delta R$$

and is thus directly and conveniently determined.

The Decremeter.—To facilitate the rapid and accurate measurement of decrement, without necessitating the accurate determination of an energy distribution curve, an instrument called a decremeter has been developed by the Bureau of Standards ² which directly measures the decre-

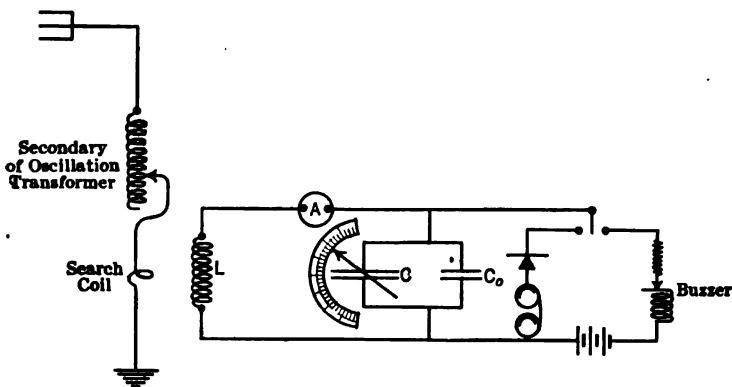

FIG. 24.—Arrangement of circuits in the decremeter.

ment of radio frequency oscillations. This instrument is similar to the wave-meter, but is equipped with a variable condenser of special design, permitting a direct-reading decrement scale to be attached to the rotating element. The connections of the instrument are shown in Fig. 24, which illustrates the similarity to the wave-meter, differing only in that a fixed

¹ Lehrbuch der Drahtlosen Telegraphie, Zenneck, 1913, page 142.

² The instrument is generally called a Kolster decremeter, as Dr. F. A. Kolster was responsible for its development.

capacity is shunted across the special variable condenser. The function of this fixed condenser is described later.

It will be recalled that

$$\delta_1 + \delta_2 = \pi \frac{C_2 - C_1}{C_2 + C_1}, \text{ for } I^2 = \frac{1}{2} I_r^2.$$

The fundamental requirement of a variable condenser which is to be used in the decremeter is that the *fractional change* in its capacity must be directly proportional to the angular movement of the rotating element and independent of the final value of capacity, or,

$$\frac{dC}{C} = m d\theta.$$

$$\therefore \log_e C = m\theta + h,$$

and

$$C = e^{m\theta + h} = a e^{m\theta}, \quad \dots \dots \dots (13)$$

where

$$a = e^h.$$

If $\theta = 0$,

$C_0 = a e^0 = a$ = initial value of capacity. This is the fixed condenser connected across the variable condenser as indicated in Fig. 24 and previously referred to.

The maximum capacity is also,

$$C_{180} = a e^{m2\pi},$$

and the ratio of maximum to minimum capacity is therefore,

$$\frac{C_{180}}{C_0} = \frac{a e^{m2\pi}}{a} = e^{2\pi m} = K. \quad \dots \dots \dots (14)$$

The capacity of the fixed condenser C_0 is determined experimentally and is made of such value as to make K of the most suitable value for the particular requirements of the decremeter. Since K is thus determined, m will be obtained by means of Eq. (14) given above.

A rotary condenser constructed in accordance with the above requirements, with a fixed capacity C_0 connected in parallel, so chosen as to give the desired ratio between the maximum (C_{180}) and minimum capacity (C_0) of the combined condensers, has been found to give a calibration curve in exact agreement with the theoretical value.

The derivation of the equation for the boundary curve of the moving element is as follows:

From Eq. (13)

$$C = a e^{m\theta}.$$

Therefore

$$A = b e^{m\theta},$$

where
and

A is the active area of the moving plate,
 θ is the angular displacement.

Also

$$\frac{dA}{A} = m d\theta,$$

or,

$$dA = b m e^{m\theta} d\theta.$$

But, referring to Fig. 25,

$$dA = \frac{1}{2}(\rho^2 - r^2) d\theta,$$

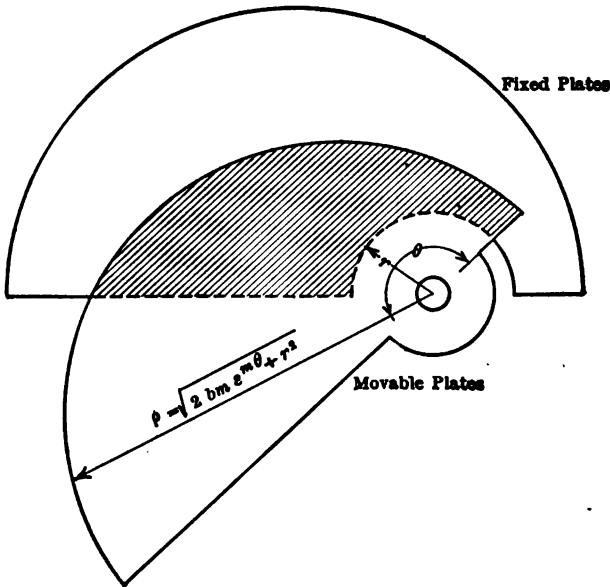

FIG. 25.—Form of plates used in the decimeter condenser.

where

ρ is the radius vector from the axis to the enveloping curve,

and

r is the radius of the circular space occupied by the separating washers between the plates.

Equating the above expressions for dA , we have,

$$\frac{1}{2}(\rho^2 - r^2) d\theta = b m e^{m\theta} d\theta$$

or

$$\rho = \sqrt{2 b m e^{m\theta} + r^2}, \dots \dots \dots (15)$$

where b and m are design constants, which determine the minimum and maximum values of the capacity to be used ($b = K'a$ while m is the same

as in previous expressions). These are arbitrarily chosen to suit the particular requirements of the special instrument.

Fig. 25 illustrates the form of the movable plate when designed in accordance with the above expression. The stationary plate is made semicircular for convenience. In Fig. 26 is shown a view of the inside of a decremeter, showing the peculiarly shaped plates of the condenser. This cut is taken from Circular 74 of the Bureau of Standards, a book every student of radio should possess.

The Manipulation of the Decremeter—Measurement of Decrement—
The manipulation of the decremeter is quite similar to that outlined for

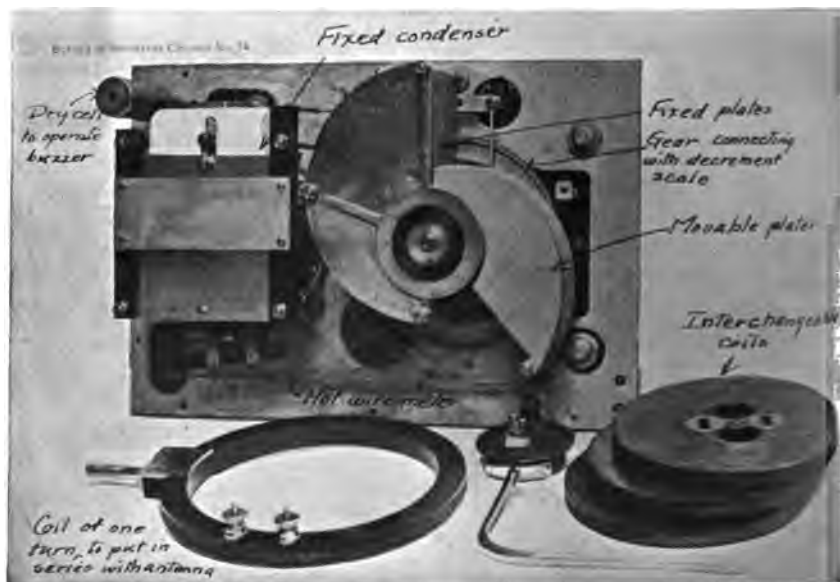

FIG. 26.—Arrangement of the different parts of a Kolster decremeter.

the wave-meter. The instrument is loosely coupled to the exciting circuit as shown in Fig. 24 and tuned to resonance, as indicated by a maximum reading on the hot-wire ammeter, this instrument usually being graduated to read I^2 . The condenser value is then decreased to C_1 , the hot-wire ammeter then reading $\frac{I_1^2}{2}$. The decrement scale is then set to zero and clamped to the condenser shaft, after which the condenser is rotated until the value C_2 is reached, at which point the ammeter indication is again one-half of that obtained at resonance. The reading of the decrement scale then gives the sum of the two circuit decrements δ_1 and δ_2 directly. It has been found that the angular deflection of the condenser

element for commercial decrements is very small, and the decrement scale, if connected directly to the condenser shaft, would be crowded and difficult to read accurately. Therefore it is usual to gear the scale to the condenser shaft, the relative angular motion of the decrement scale and capacity element being about 6 : 1.

The decrement of the meter for all values of C and for each of three fixed inductance coils which may be used is known from curves supplied with the instruments. These decrements vary from about .07 to .02, the larger value corresponding to a large value of C and smallest value of L . The smaller value is obtained with C at its minimum value and the largest inductance inserted in the circuit.

Measurement of Resistance.—Knowing δ_1 , the decrement of the circuit, the resistance is at once known at the frequency of oscillation from the following relations, which have previously been deduced :

$$\delta_1 = \pi R \omega C = \frac{\pi R}{L \omega} = \pi R \sqrt{\frac{C}{L}}$$

The capacity C and inductance L of the circuit, if unknown, are simply determined by means of a wave-meter as outlined on page 814. The decremeter is thus valuable as a means of determining high-frequency resistance.

Measurements of Wave-length.—The Kolster decremeter described above is evidently also applicable to the measurement of wave-lengths, and the variable condenser is therefore equipped with a scale indicating directly the wave-lengths in meters corresponding to the condenser adjustment. The instrument as usually furnished, is equipped with three inductances to cover the range of wave-lengths required, this being about 300 to 2500 meters.

Measurement of Phase Difference of a Condenser.¹—The decremeter may also be used to measure the phase difference of a condenser, since

$$\text{phase difference } \psi = R \omega C = \frac{\Delta \delta}{\pi} \text{ (in radians), (16)}$$

or,

$$\psi = 18.24 \Delta \delta \text{ (in degrees), (16')}$$

where $\Delta \delta$ is the increase in total decrement due to inserting the condenser in the circuit.

The condenser is inserted in the decremeter circuit, which is then tuned to an undamped wave-exciting source. The decrement measured under these conditions is the sum of δ_2 and $\Delta \delta$, where δ_2 may be obtained from the calibration curves furnished with the instrument. Substituting $\Delta \delta$ in the above expressions, the phase difference ψ is readily obtained.

¹ See Chapter II, page 171.

Use of Wave-meter to Measure L and C .—A wave-meter may be used to measure an unknown inductance or capacity, provided a known capacity or inductance respectively are available. The procedure then is simply to connect the unknown inductance and known condenser (or known inductance and unknown condenser), into an oscillatory circuit, as shown in Fig. 27, excited by means of a buzzer. Loosely coupled to this primary circuit is the wave-meter, by means of which the wave-length of the test circuit oscillations may be obtained.

When making this determination, it is important that the coupling between the two circuits be very loose, if accurate results are to be obtained. Also the leads used in making up the test circuit should be as short as possible, to minimize the error due to the distributed capacity (shown in figures in dotted lines), and inductance of the leads which would tend to increase the measured wave-length. It may be found impossible to

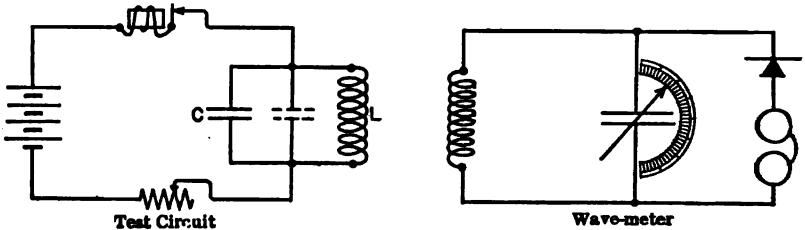

FIG. 27.—Use of wave-meter to measure L or C .

tune out the signal, in which case the coupling should be decreased, and all direct induction effects from the buzzer circuit (to which this continuous note is due) minimized or eliminated by making the buzzer circuit as compact as possible. If no point of maximum note occurs as the wave-meter condenser is varied, it is probable that the wave-length of the test circuit is beyond the range of the instrument. The remedy is evidently to change the known value of inductance (or capacity) in the test circuit, or to try others of the various coils with which the wave-meter is equipped.

After the wave-length has been determined, the unknown value of inductance (or capacity) is given at once by the formula,

$$\lambda_{\text{meters}} = 1885\sqrt{LC},$$

L and C being measured in micro units.

Equivalent results are obtained if the wave-meter is employed as the exciting circuit. The connections are then as shown in Fig. 28. The wave-length of the wave-meter oscillations is varied until a maximum note is heard in the phones across the test circuit, under which condition the natural frequency of both circuits is in agreement.

The same precautions are to be observed in this case as for the preceding method, with especial reference to the phone circuit connected across

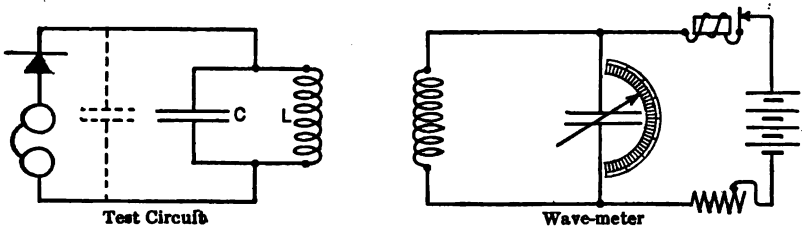

FIG. 28.—Another method of measuring L or C , using the wave-meter as a buzzer excited wave generator, of known calibration. Note that the calibration of a given wave-meter will generally be different when used as here shown than when used as in Fig. 27.

the test circuit. Long, twisted leads must especially be avoided as these will cause large error, due to their distributed capacity (conventionally

shown in dotted lines, Fig. 29) particularly if the test circuit capacity is small. It is to be noted that a wave-meter will have a different calibration when used with a hot-wire meter for indicator, and when detector and phones, or buzzer, is connected in parallel with its condenser. The amount of correction required is greatest for the lowest settings of the wave-meter condenser.

Use of Wave-meter to Measure the Constants of an Antenna. — Another

important measurement involving the use of the wave-meter is that of the constants of an antenna. The loading coils, short-wave condenser and oscillation transformer are first removed from the antenna

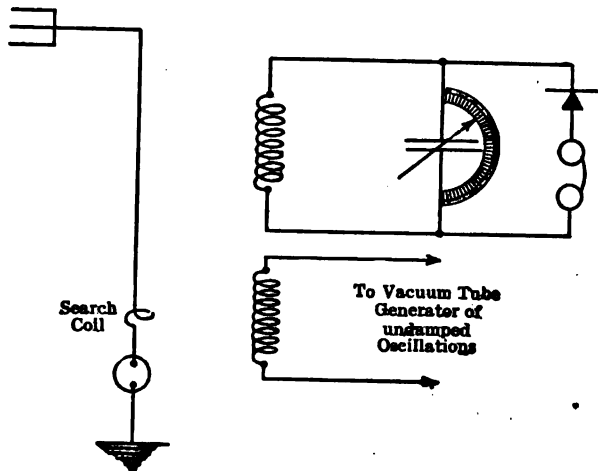

FIG. 29.—To measure the natural wave-length of an antenna the antenna is coupled (by a small search coil) to a source of continuous wave power of variable frequency. When the antenna ammeter reads a maximum, the wave-meter is used to read wave-length of power. If a d.c. generator is used in the plate circuit of the tube generator the phones and detector may be used for getting resonance, the commutation ripples being audible; otherwise an ammeter will be used in the wave-meter circuit.

circuit and a search coil of negligible inductance inserted in the circuit as shown in Fig. 29.

The antenna is then excited by undamped wave-oscillations, using a vacuum-tube generator of sufficient power and with the coupling made loose enough to prevent any appreciable variation of plate current due to reactive effects of the antenna circuit. The generator frequency is varied until the antenna ammeter *A* indicates a maximum and the wave-length of the tube circuit for this adjustment is then determined by means of the wave-meter. This value represents the *natural* wave-length of the antenna, and is expressed by,

$$\lambda_0 = 1885\sqrt{L_0C_0},$$

when L_0 and C_0 are the effective inductance and capacity of the antenna for the quarter wave-length oscillation. In the figure the antenna ammeter represents a sensitive current meter, involving a thermo-couple and galvanometer, or similar device.

To determine L_0 , an additional known inductance L_1 is inserted in the antenna circuit and the new wave-length λ_1 determined for this condition. Thus:¹

$$\lambda_1 = 1885\sqrt{(L_0 + L_1)C_0}.$$

Therefore,

$$\begin{aligned} \frac{\lambda_1^2 - \lambda_0^2}{(1885)^2} &= (L_0 + L_1)C_0 - L_0C_0 \\ &= L_0C_0 + L_1C_0 - L_0C_0 \\ &= L_1C_0 \end{aligned}$$

or²

$$C_0 = \frac{\lambda_1^2 - \lambda_0^2}{(1885)^2 L_1} \dots \dots \dots (17)$$

Substituting this value for C_0 in the above expression for λ_0 , L_0 is obtained as follows:

$$\begin{aligned} \frac{\lambda_0^2}{(1885)^2} &= L_0C_0 = \frac{L_0(\lambda_1^2 - \lambda_0^2)}{(1885)^2 L_1}, \\ L_0 &= \frac{\lambda_0^2 L_1}{\lambda_1^2 - \lambda_0^2} \dots \dots \dots (18) \end{aligned}$$

The following alternative method may also be employed. The known inductance inserted in the circuit is assumed to be the only inductance

¹ In the equations given, the wave-length is expressed in meters, while inductance and capacity are expressed in microhenries and microfarads respectively.

² This deduction is a very simple one and suffices for ordinary purposes. It must be noted, however, that actually C_0 , the same as L_0 , is not a constant, but varies as different values of loading are used. For an analysis of this point see Morecroft, "Some Experiments with Long Electrical Conductors," Proc. I. R. E., Dec., 1917, and Miller "Electrical Oscillations in Antennæ and Inductance Coils, Proc. I. R. E. (June, 1919): also discussion of Miller's paper in Proc. I. R. E., Dec., 1919.

present, i.e., L_0 is negligible compared to L_1 . This requires that L_1 be large enough to give the antenna a wave-length about five times as great as its natural wave-length.

Then we may put

$$\lambda_1 = 1885\sqrt{L_1 C_0},$$

and

$$C_0 = \frac{\lambda_1^2}{1885^2 L_1}.$$

The known inductance is now removed from the circuit and the natural wave-length of the antenna is accurately measured.

Then,

$$\lambda_2 = 1885\sqrt{L_0 C_0},$$

and

$$\frac{\lambda_2^2}{1885^2} = L_0 C_0 = \frac{L_0}{L_1} \cdot \frac{\lambda_1^2}{1885^2},$$

or

$$L_0 = \frac{\lambda_2^2}{\lambda_1^2} L_1.$$

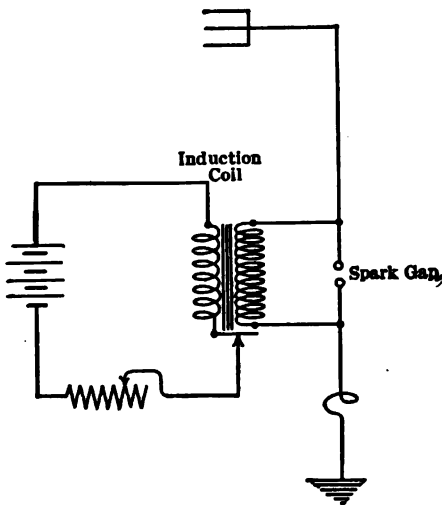

If the value of L_0 obtained from this equation shows it to be negligible compared to L_1 , as assumed, then the determinations for L_0 and C_0 may be accepted. If this is not the case, the obtained value for L_0 must be added to L_1 and the calculation for C_0 repeated.

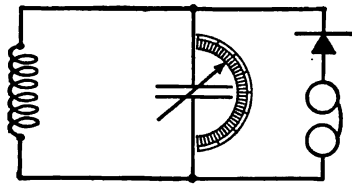

FIG. 30.—In case a very short spark gap, a low-powered induction coil, and very weak coupling are used the phones and crystal detector may be used for getting resonance in the wave-meter, otherwise the ammeter will be used to indicate resonance.

Where undamped oscillations are not available an induction coil or low-powered transformer may be used to excite the circuit as shown in Fig. 30.

In this case the gap resistance has been inserted in the circuit and the observed wave-length may therefore be slightly greater than with the

previous method. An alternative method is shown in Fig. 31, with which arrangement the antenna is charged to battery voltage when the buzzer contact is open and then discharges through the buzzer contact when this closes.

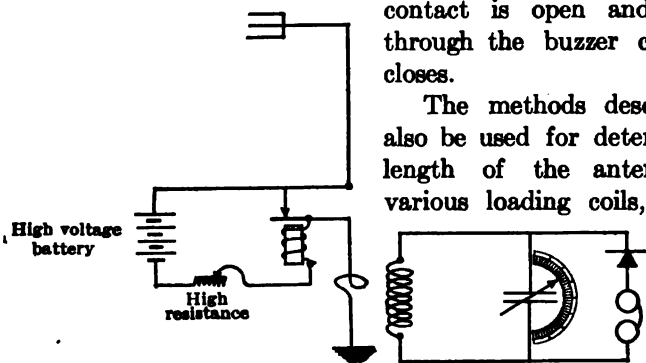

FIG. 31.—Use of buzzer for determining the natural wave-length of an antenna.

In all cases the closed circuit of the transmitting set should be open to prevent interference effects.

When the inductance of the search coil required for coupling to the generator circuit (Fig. 28), is not negligible, the natural wave-length λ_0 cannot be determined directly, but is determined from two measurements as follows:

$$\lambda_1 = 1885\sqrt{(L_0 + L_s)C_0}, \tag{a}$$

where L_s = inductance of search coil,

$$\lambda_2 = 1885\sqrt{(L_0 + L_s + L'_s)C_0}, \tag{b}$$

where L'_s = additional known inductance inserted which is made equal to L_s .

$$\therefore \frac{\lambda_2^2 - \lambda_1^2}{(1885)^2} = L_0C_0 + 2L'_sC_0 - L_0C_0 - L'_sC_0 = C_0L'_s$$

or

$$C_0 = \frac{\lambda_2^2 - \lambda_1^2}{(1885)^2 L'_s} \tag{18}$$

Substituting in (a),

$$\frac{\lambda_1^2}{1885^2} = \frac{(L_0 + L'_s)(\lambda_2^2 - \lambda_1^2)}{1885^2 L'_s},$$

$$L'_s \lambda_1^2 = L_0(\lambda_2^2 - \lambda_1^2) + L'_s(\lambda_2^2 - \lambda_1^2)$$

or

$$L_0 = \frac{L'_s(2\lambda_1^2 - \lambda_2^2)}{\lambda_2^2 - \lambda_1^2} \tag{19}$$

Knowing C_0 and L_0 , the natural wave-length λ_0 is obtained from the relation:

$$\lambda_0 = 1885\sqrt{L_0C_0}.$$

In the above it has been assumed that $L' = L_2$. This is a purely arbitrary relationship and it is usually preferable to make L' , larger than this, say five or ten times L_2 , so that the difference between λ_1 and λ_2 is increased and the experimental errors involved in the measurement thus decreased.

Determination of Mutual Inductance and Coefficient of Coupling.—The wave-meter also forms a convenient instrument for readily determining the mutual inductance existing between the closed and open circuits of

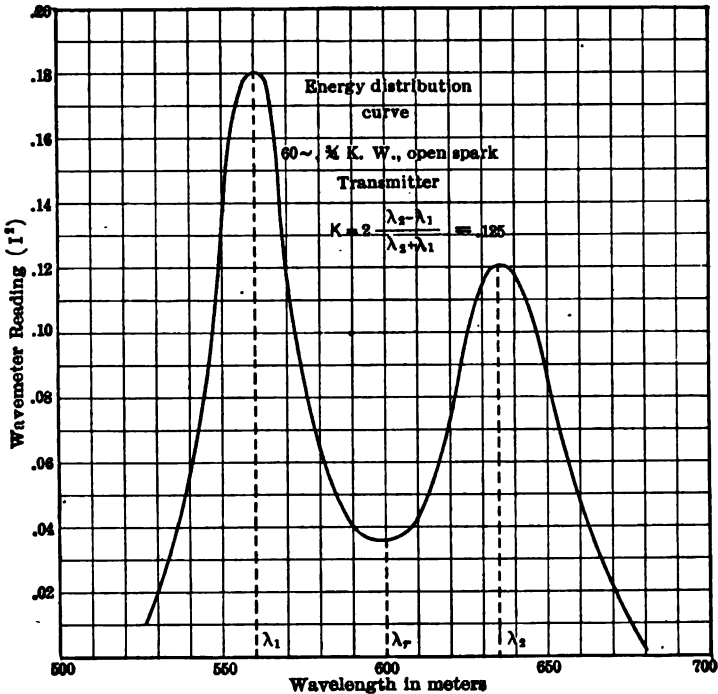

FIG. 32.—From an energy distribution curve, obtained with non-quenching gap, the coefficient of coupling may be obtained from the spacing of the two resonance peaks.

transmitting set. If we know the coefficient of coupling K , the mutual inductance M ($M = K\sqrt{L_1L_2}$, where L_1 and L_2 are the total inductance of the closed and open circuits, respectively) is readily obtained, L_1 and L_2 being determined as described on page 814.

The following two methods may be used:

(a) An energy distribution curve is determined for the set as shown in Fig. 32, from which λ_1 and λ_2 , corresponding to the peaks in the curve, are readily determined.

Since

$$\lambda_1 = \lambda_0 \sqrt{1 - K},$$

and

$$\lambda_2 = \lambda_0 \sqrt{1 + K},$$

we have,

$$\frac{\lambda_1^2}{\lambda_2^2} = \frac{1 - K}{1 + K},$$

$$\lambda_1^2 + \lambda_1^2 K = \lambda_2^2 - \lambda_2^2 K$$

$$(\lambda_2^2 + \lambda_1^2) K = \lambda_2^2 - \lambda_1^2$$

$$K = \frac{\lambda_2^2 - \lambda_1^2}{\lambda_2^2 + \lambda_1^2} \dots \dots \dots (20)$$

Since

$$\lambda_r \text{ is approximately equal to } \frac{\lambda_2 + \lambda_1}{2},$$

and

$$\lambda_r^2 \text{ is approximately equal to } \frac{\lambda_2^2 + \lambda_1^2}{2},$$

we have,

$$K = \frac{(\lambda_2 - \lambda_1)(\lambda_2 + \lambda_1)}{2\lambda_r^2} = \frac{(\lambda_2 - \lambda_1)(2\lambda_r)}{2\lambda_r^2},$$

or

$$K = \frac{\lambda_2 - \lambda_1}{\lambda_r} = 2 \frac{\lambda_2 - \lambda_1}{\lambda_2 + \lambda_1} \dots \dots \dots (21)$$

The latter forms are somewhat simpler than the more accurate expression, as no squared terms are involved. They are, however, accurate enough for most commercial determinations. The last form is perhaps the most desirable, as it eliminates all measurement of λ_r .

(b) The second method is as follows: The oscillation transformer primary and secondary are connected in series in the closed circuit as shown in Fig. 33.

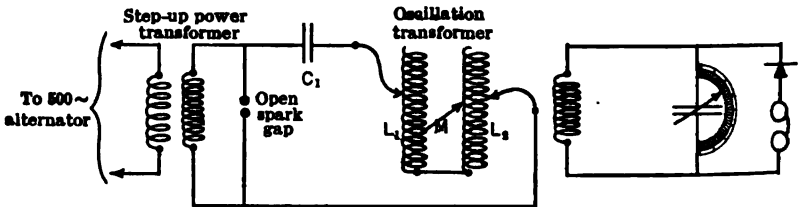

FIG. 33.—Unless a very short spark gap (hence low power) is used the hot-wire ammeter (or similar indicator) would be used in place of the phones and detector.

To get greater accuracy the loading coils should be disconnected and removed from the secondary circuit, so that only those inductances are involved which are coupled during the operation of the set, i.e., the primary and secondary of the oscillation transformer. Damped oscillations

are then set up in this circuit as in the normal operation of the transmitter and the wave-length noted. Calling this wave-length λ_1 , L' , the total inductance in the circuit, is obtained from

$$L' = \frac{\lambda_1^2}{1885^2 C_1} = L_1 \mp 2M + L_2.$$

The connections to one coil are then reversed and the readings repeated. In this case,

$$L'' = \frac{\lambda_2^2}{1885^2 C_1} = L_1 \mp 2M + L_2.$$

Therefore

$$L' - L'' = 4M$$

$$M = \frac{L' - L''}{4} \dots \dots \dots (22)$$

or

$$= \frac{L'' - L'}{4},$$

according as L' is greater than L'' or vice versa.

Then when the set is in normal operation, using loading coils, etc., we find the coupling coefficient from the relation

$$K = \frac{M}{\sqrt{L_1 L_2}}, \dots \dots \dots (23)$$

where L_1 is the total inductance in the primary circuit under normal operation;
 L_2 is the total inductance in the secondary circuit under normal operation, i.e., the inductance of the oscillation transformer secondary + the effective inductance of the antenna + the inductance of the loading coil (if inserted).

The above methods are exactly equivalent in result and may be used indiscriminately. Method (b) is perhaps the better, since the considerable amount of data needed to plot accurately an energy distribution curve is not required. Sometimes, however, this curve is required as illustrating an operating characteristic of the set, and the coupling is then most simply determined by the relationships developed in Method (a).

How to Improvise a Wave-meter.—The varied and important uses of the wave-meter as described on the preceding pages have made it a fundamental and essential part of any radio laboratory or station equipment. Now and then occasions may arise where this instrument may not be available, through loss, damage, etc., and in this case, a "home-made" instrument must be devised. Also, a large majority of amateur operators prefer to construct their own meters for the enjoyment and

experience which such constructive work brings to them. For these reasons it has been considered desirable to give a brief outline of the procedure to be followed.

One of the first points to be decided is: What shall be the maximum wave-length which the wave-meter to be designed is to measure? We will assume this to be 2000 meters. A suitable variable condenser must next be chosen, and as one or more variable condensers are normally available in even the simplest installations we will consider that such condensers are available in this case. The maximum capacity of the several condensers should be measured, either electrically, or from their dimensions, by means of the expression given on page 165, Eq. (30).

The wave-meter condenser should have about .001 microfarad capacity per 1000 meters maximum wave-length to be measured. Thus, for this problem, the capacity should be .002 microfarad and that condenser should be chosen which possesses at least this capacity.

The maximum wave-length and capacity thus being determined, the required inductance is readily obtained from

$$\lambda_{\text{meters}} = 1885\sqrt{L_{\mu\text{h}}C_{\mu\text{f}}}$$

or

$$2000 = 1885\sqrt{L_{\mu\text{h}} \times .002}$$

$$1.125 = L_{\mu\text{h}} \times .002$$

$$L = 563 \text{ microhenries.}$$

This inductance should then be designed (generally in the form of a single layer solenoid) in accordance with the formula given on page 145 Eq. (11). The coil should be wound with finely stranded wire, the individual strands being insulated to minimize the resistance of the wave-meter.

A small hot-wire ammeter (0-100 milliamperes preferable) should

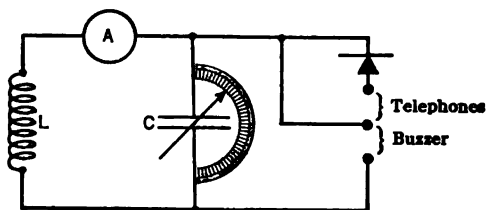

FIG. 34.—A convenient arrangement of terminals for a wave-meter.

then be obtained and assembled with the condenser and coil, the connections being made as shown in Fig. 34.

All connections should be well made and the circuit made as compactly as possible so as to minimize the resistance of the wave-meter. This equipment may

then be enclosed in any wooden box of convenient size, with only the ammeter and condenser index and associated scale visible. Additional

binding posts may be added for phones, detector, and buzzer circuit as shown.

The wave-meter is then ready for calibration, which may be accomplished by coupling the instrument to a transmitter which may be adjusted to radiate at several known wave-lengths. A few points on the scale may be approximately determined by using the wave-meter (with detector and phones as indicating devices), as the closed circuit of a receiving set, coupled very loosely to the antenna. A few stations of known wave-length may generally be heard in this way, and so a few points of calibration obtained. A curve should then be plotted between the known wave-lengths and corresponding positions of the condenser index (the condenser scale is usually graduated in degrees or in 100 divisions to the semicircle). This curve will have an appearance similar to the wave-length curve in Fig. 11. The decrement of the meter may also be measured by one of the methods described above, and should not exceed .10 for an average value of the condenser.

CHAPTER XI

AMPLIFIERS

Amplifiers in General.—An amplifier is, as the name implies, an apparatus for increasing the strength of incoming signals. It performs in modern radio communication, and also in ordinary wire communication, a very important function, in so far as it makes possible the detection of very feeble signals and thus increases the practical range of transmission.

The reader is already familiar with the fact that the signals received in radio transmission consist of very high-frequency currents and voltages which may be of constant or varying amplitude, depending upon the system used. These signals are generally "heard" in telephone receivers by first reducing the frequency of the incoming currents and voltages from a very high value to an "audible value," and thereafter causing the "audio-frequency" currents to flow through the receivers. In using an amplifier either of the following two schemes may be resorted to:

(a) The amplifier may be so connected that the incoming high-frequency currents and voltages are first strengthened and thereafter reduced in frequency.

(b) The amplifier may be so connected as to strengthen the currents and voltages *after* they have been reduced in frequency.

The above forms the basis of the division of amplifiers into two general classes, i.e., "high-frequency" and "low-frequency."

While these two general types of amplifiers are fundamentally the same, yet the constants of the apparatus used in their construction are often so different that the two types cannot, in general, be used interchangeably.

The amplifiers used in radio communication consist invariably of one or more three-electrode vacuum-tubes with other suitable apparatus. As a matter of fact, it was not until the advent of the vacuum-tube that suitable amplifiers could be constructed and operated. The characteristics of a good amplifier should be such that the signal currents are strengthened without any distortion; the vacuum-tube can be made to fulfill these two conditions admirably, and it is practically the only apparatus which can. It will be noted from this brief outline that an amplifier must be a kind of trigger which, actuated by the very weak voltages impressed by the antenna, releases from a local energy supply

amount of energy much greater than that actuating the antenna. The suitability of the three-electrode tube for this purpose is at once evident from the analysis of its action given in Character VI.

The General Characteristics of Triodes.—These have been quite thoroughly discussed in Chapter VI; on pages 570 et seq. the possibility of using a tube as an amplifier was pointed out and an elementary analysis given.

The “static” relation between the plate current and grid and plate potentials was shown to be expressible by

$$I_b = A(E_g + \mu_0 E_c)^{\frac{2}{3}}, \quad \dots \dots \dots (1)$$

and it was also pointed out that, for small variations in the tube potentials, the exponent might be treated as unity.

It was further shown that, if a sufficiently small sine wave e.m.f. was impressed on the grid, the pulsations in the plate current would be sinusoidal in form, and the constant (1/A) acquires the significance of “alternating current plate circuit resistance.”

We then have the equation which was used throughout Chapter VI in analyzing tube action, i.e.:

$$I_p = \frac{1}{R_p}(E_p + \mu_0 E_g), \quad \dots \dots \dots (2)$$

where

- I_p = effective value of alternating component of plate current;
- R_p = alternating current plate circuit resistance;
- E_g = effective value of alternating component of grid voltage;
- E_p = effective value of alternating component of plate voltage.

We must point out again the limitations of the applications of this relation. The steady values (c.c. components) of grid and plate potentials must be so chosen that, for the value of E_g impressed the linear relation of Eq. (2) holds good. This requires in general that E_c and E_b of Eq. (1) above be properly related.

As pointed out on page 577 and illustrated by the curves of Fig. 184, page 576, when there is considerable outside impedance in the plate circuit the plate current changes linearly with respect to E_p over much wider ranges than might be judged from the static characteristic. This is conventionally illustrated in Fig. 1. With no external resistance in the plate circuit the static characteristic of a tube might be as shown by curve A, whereas if a resistance is put in series with the plate (about equal to R_p) and the plate voltage E_p be increased sufficiently to make I_b (for $E_g = 0$) the same

as for curve *A*, then curve *B* will be obtained, which is evidently of such a shape as to satisfy Eq. (2) over a change in E_c from perhaps -4 volts to zero.

Hence if the value of E_c is chosen as -2 volts the tube having characteristics shown in Fig. 1 would operate satisfactorily with an impressed alternating grid signal of 2 volts maximum value.

It will be noticed that, even with the grid potential positive, curve *B* is still nearly straight so that it might seem possible to operate the tube

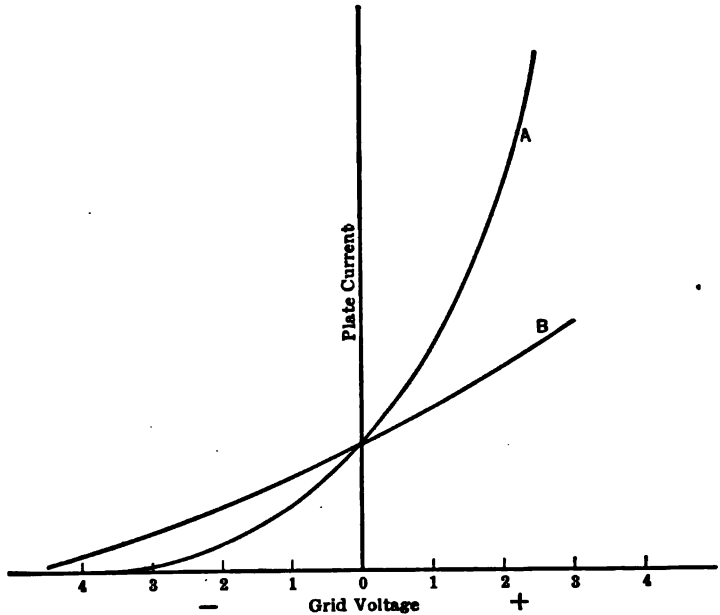

FIG. 1.—Showing the effect on the plate current—grid potential curve of a tube of putting external resistance in the plate circuit; a tube which by itself gives characteristic *A*, will give characteristic *B* if sufficient external resistance is put in the plate circuit and the voltage in this circuit suitably increased.

satisfactorily with signals sufficiently intense to make the grid swing positive. Such is not the case, however; if the grid is allowed to become positive it takes current (it takes negligible current as long as it is negative), and, as will be explained later, this seriously interferes with proper amplification.

In order to keep the grid of an amplifier suitably negative either a small dry battery may be inserted in the grid leak resistance circuit, or the leak resistance may be attached to a point in the filament circuit which is sufficiently negative with respect to the filament. These two schemes are indicated in Fig. 2, *a* and *b*; in scheme *b* an extra resist-

ance R is put in series with the filament having such a resistance that when normal filament flows through it the IR drop is the required amount. In some multi-stage amplifiers (several tubes repeating one into the other) the filaments are all connected in series to the A battery, the filament of the preceding tube may serve as the resistance R , as indicated in Fig. 3. In the operation of tubes as amplifiers the following quantities play a very important part:

- (a) A.C. resistance of plate to filament or output circuit of tube.
- (b) A.C. resistance of grid to filament or input circuit of tube.
- (c) Capacity of grid to filament under static conditions and under actual operating conditions.

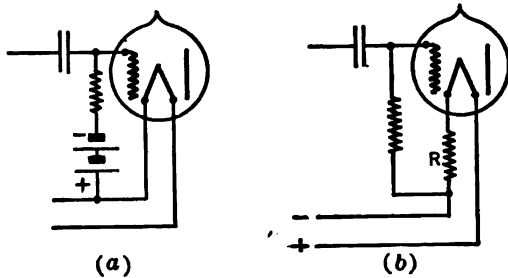

FIG. 2.—To keep the grid of an amplifier tube negative either a small battery of dry cells may be used (a) or a resistance inserted in the negative leg of the filament may be employed (b).

All of the above quantities have been fully discussed in Chapter VI, and the reader will do well, before proceeding with the study of this chapter, to go over the fundamental principles of three-electrode tubes as outlined at the beginning of Chapter VI. The fact should here be emphasized that the capacity of the grid to filament, while small under static conditions, may attain comparatively large values under actual operating conditions.

Again the circuit from plate to filament or grid to filament is made up of a resistance in multiple with a capacity, and, while ordinarily the impedance of either circuit is practically equal to its resistance, there are cases when the frequency is

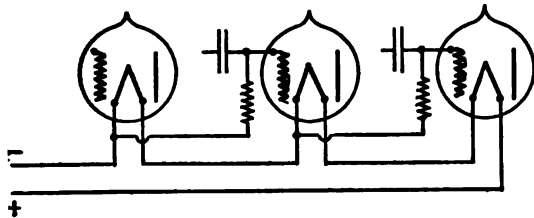

FIG. 3.—In case several tubes are used in cascade it is possible to connect all filaments in series and connect the leak resistances behind the filament of the preceding tube. This makes the grid of each tube negative with respect to its filament by an amount equal to the IR drop of the filaments.

high enough to make the impedance much less than the resistance. That is, the capacity reactance of the circuits, shunting the resistance, may be low enough to determine the impedance of the path.

Effect of External Resistance in the Plate Circuit.—As pointed out in Chapter VI the function of a triode when used as amplifier is to make

available in the external plate circuit a voltage similar to that impressed on the grid, and as much larger as feasible. The amount of increase depends upon the μ_0 of the tube used, and on the impedance introduced in the plate circuit.

If a resistance R is put in the external plate circuit the total impedance of the plate circuit is $R_p + R$. The magnitude of alternating current set up in the plate circuit by a sine voltage E_g , acting between grid and filament is given by

$$I_p = \frac{\mu_0 E_g}{R_p + R} \dots \dots \dots (3)$$

and this alternating current flowing through the resistance R gives an available voltage in the plate circuit of

$$I_p R = E_g \mu_0 \frac{R}{R_p + R} \dots \dots \dots (4)$$

This is indicated in Fig. 4 and experimental curves showing how the amplifying power of a tube varies with the value of R used are given in Fig. 181 of Chapter VI.

It is evident that if resistance is used in the plate circuit, more voltage must be supplied by the B battery to maintain the plate voltage at its proper value. Unless this is done the expected amplification $\mu_0 \frac{R}{R_p + R}$

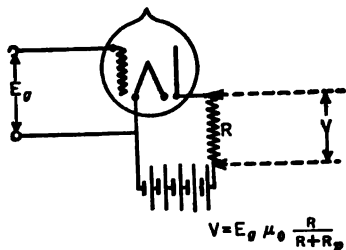

FIG. 4.—Amount of amplified voltage with resistance in plate circuit.

does not increase with R as rapidly as might be expected because as R is increased the plate voltage (which is equal to $E_b - I_p R$) decreases and as pointed out on page 425, this gives an increase in R_p . Hence if resistance is used in the plate circuit of an amplifying tube the B battery e.m.f. must be considerably greater than rated plate voltage of the tube, ordinarily two or three times as much. If the external resistance R is taken equal to the tube resistance R_p , the B battery must have a voltage twice as great

as the rated plate voltage of the tube, and the amount of voltage amplification obtainable is $\frac{\mu_0}{2}$.

The amplifying power of a tube of having the grid at different potentials, E_c , is well brought out by the curves of Fig. 183, page 575. It is there seen that not only must a proper plate resistance be used, but also the grid must be at a proper potential if the maximum possible amplification is to be obtained.

Effect of Reactance in the Plate Circuit.—If we use in the plate circuit, a low-resistance reactance, instead of a resistance, the amplifying qualities of the tube are much better. Thus if we put in series with the plate, $Z = R + j\omega L$, we shall then have the relation shown in Fig. 5. We must have from Eq. (2)

$$I_p = \frac{\mu_0 E_g}{\sqrt{(R_p + R)^2 + \omega L^2}}$$

and hence the available drop in the external circuit is

$$E_g \mu_0 \frac{Z}{\sqrt{(R_p + R)^2 + \omega L^2}} \dots \dots \dots (5)$$

It is to be pointed out here that R and L are the alternating current constants of coil Z , measured under the conditions which obtain in the actual use of the coil; i.e., R and L must be measured in an a.c. bridge (or similar scheme) with the frequency and magnitude of voltage to which the coil is subjected when used in the tube circuit. Also when these measurements are made there must be flowing through the coil a continuous current equal to the average plate current, I_b . These precautions in determining Z are not necessary if an air core coil is used, but this is seldom the case; generally an iron core coil is used.

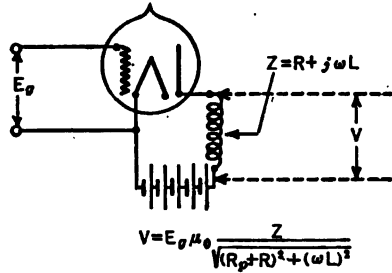

FIG. 5.—Amount of amplified voltage with inductance in plate circuit.

If now the resistance R is small compared to R_p and ωL we can write the voltage amplification of the tube and circuit as

$$I_p \omega L = E_g \mu_0 \frac{\omega L}{\sqrt{R_p^2 + \omega L^2}} \dots \dots \dots (6)$$

The voltage amplification,

$$\mu_0 \frac{\omega L}{\sqrt{R_p^2 + \omega L^2}},$$

may be made nearly equal to μ_0 , by making ωL sufficiently large and at the same time the B battery need have a voltage only equal to the actual voltage of the tube (on the assumption that the resistance of the coil is negligible compared to R_p).

Classification of Amplifiers.—An amplifier generally consists of two or more vacuum tubes so arranged that the varying signal voltage is impressed upon the grid of the first tube, thus producing a variation of the plate current in this tube; this varying plate current is, then, made

to produce a varying voltage between the grid and filament of the second tube, and, similarly, the varying voltage is relayed from the second to the third tube, etc., until the plate circuit of the last tube is reached, wherein are placed the telephone receivers or any other device used for making the signals readable. From this brief description it is plain that the signals must be "repeated" from one tube into the next. Amplifiers, either for low-frequency or for high-frequency, are divided into the following classes, according to the arrangement used for "repeating."

- (1) Transformer-repeating amplifiers.
- (2) Resistance-repeating amplifiers.
- (3) Inductance-repeating amplifiers.

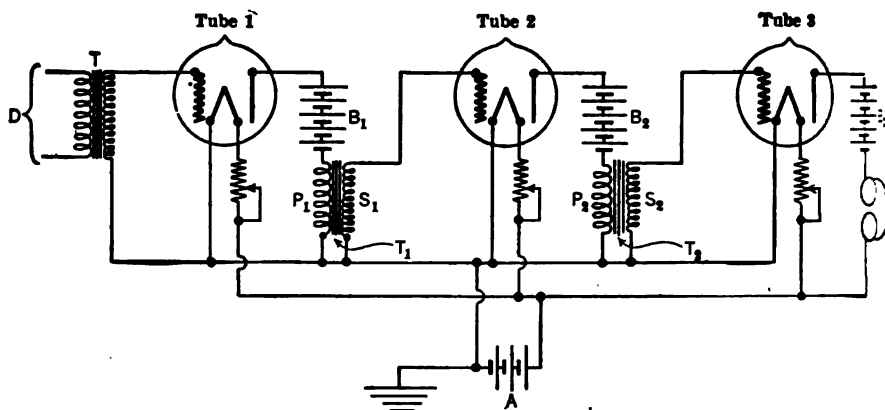

FIG. 6.—A transformer repeating amplifier for audio-frequencies.

A tube, together with all co-acting apparatus, is known in amplifier work as a "stage of amplification"; and an amplifier consisting of n tubes is known as an n -stage amplifier.

The two terminals of the amplifier upon which the incoming signal voltages are impressed are known as the "input" terminals, while the two terminals across which exist the amplified signal voltages are known as the "output" terminals.

Transformer-repeating Amplifiers.—These are generally used for amplifying audio-frequency signals and we will discuss their principle of operation by referring to Fig. 6, which is intended to represent an audio-frequency transformer-repeating, three-stage amplifier.

The audio-frequency varying voltage is connected at D and stepped up by means of the transformer T , after which it is applied between the grid and filament of the first tube; this produces a corresponding variation of the plate current of Tube 1. The varying current flowing through the primary P_1 of the transformer T_1 induces an e.m.f. in the secondary

S_1 . This e.m.f. is applied to the grid and filament of the second tube, and thus the varying signal voltage is "repeated" from the first into the second tube and finally from the second into the third tube, the varying plate current of which is caused to affect the telephone receivers.

It will be at once apparent that in an arrangement of this kind, while each tube itself is always amplifying, the advantage of this may be lost by a poor repeating device. The object to be gained is, of course, to make the varying voltage between the grid and filament of each tube greater than for the preceding tube. This requires correct proportioning of the primary and secondary of the repeating transformers T_1, T_2 ; otherwise the grid-filament voltage of the second tube may be but slightly larger, or even smaller, than for the first tube. This is not an unusual occurrence in poorly designed "amplifiers."

We will study the repeating action from the first into the second tube. For the sake of simplicity we may assume that the repeating transformer has neither leakage inductance nor resistance and also that the magnetizing current is zero; this is equivalent to saying that the transformer is ideal. In so far as the alternating current relations of the circuit are concerned, such a transformer may, if the secondary is loaded by means of a non-inductive resistance, be replaced by a fictitious resistance placed in the primary and equal to the secondary circuit resistance divided by the square of the ratio of transformation. Let:

E_{g1} = effective value of alternating voltage between grid and filament of Tube 1;

E_{g2} = effective value of alternating voltage between grid and filament of Tube 2;

R_{p1} = plate-filament a.c. resistance of Tube 1;

R_{g2} = grid-filament a.c. resistance of Tube 2;

μ_0 = amplifying constant of Tube 1;

V = effective value of alternating voltage across primary of repeating transformer, T_1 ;

n = repeating transformer ratio expressed as the ratio of secondary to primary voltage.

The above quantities are illustrated in Fig. 7. The action of E_{g1} upon the plate current of Tube 1 is the same as if an alternating voltage equal to $\mu_0 E_{g1}$ had been impressed upon the plate circuit, in addition to the battery e.m.f. This alternating voltage $\mu_0 E_{g1}$ is impressed upon a circuit which may be simplified as shown in Fig. 8 and consisting of the plate resistance of the first tube in series with the equivalent resistance of the repeating transformer transferred to the primary. This is probably the simplest way to treat the problem when the coupling between the primary and secondary of the transformer is tight and the load circuit of the trans-

former is resistive only. For the more general case, i.e., leaky transformer and reactive secondary load, the action of the tube is best analyzed by using for the external impedance in the plate circuit the resistance and reactance of the primary of the transformer as calculated from the general equations given on pages 86-87.

From Fig. 8 the following equation is easily derived:

$$V = \frac{R_{p2}}{n^2} \mu_0 E_{g1} = \frac{\mu_0 R_{p2}}{n^2 R_{p1} + R_{p2}} E_{g1} \dots \dots \dots (7)$$

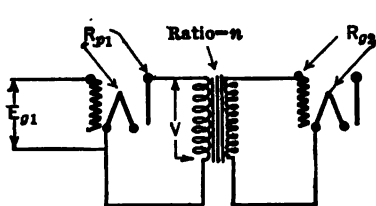

FIG. 7.

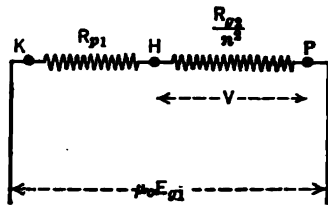

FIG. 8.

FIG. 7.—Circuit detail of the amplifier shown in Fig. 6.

FIG. 8.—Under ideal conditions (transformer requiring no magnetizing current, having zero internal impedance, and secondary load resistive only) the circuit of Fig. 7 may be replaced by the one above.

The voltage between grid and filament of the second tube is equal to the voltage across the transformer primary multiplied by the ratio of transformation; thus:

$$E_{g2} = nV = \frac{\mu_0 n R_{p2}}{n^2 R_{p1} + R_{p2}} E_{g1} \dots \dots \dots (8)$$

and

$$\frac{E_{g2}}{E_{g1}} = \frac{\mu_0 n R_{p2}}{n^2 R_{p1} + R_{p2}} \dots \dots \dots (9)$$

Eq. (9) may be written as:

$$\frac{E_{g2}}{E_{g1}} = \frac{\mu_0 n a}{n^2 + a} \dots \dots \dots (10)$$

where

$$a = \frac{R_{p2}}{R_{p1}}$$

It will be noted from Eq. (10) that the ratio $\frac{E_{g2}}{E_{g1}}$ varies directly with the amplifying constant of the first tube and it also varies in a complex manner with R_{p2}/R_{p1} and with n . It will further be noted that:

1st. If μ_0 and n are kept constant and the ratio $\frac{R_{p2}}{R_{p1}}$ increased from

a low value, then $\frac{E_{g2}}{E_{g1}}$ will constantly increase towards the limiting value $\mu_0 n$ which will be theoretically reached when $\frac{R_{g2}}{R_{g1}} = \infty$.

2d. If μ_0 and $\frac{R_{g2}}{R_{g1}}$ are kept constant and the value of n changed then $\frac{E_{g2}}{E_{g1}}$ may be shown to have a maximum when:

$$n^2 = \frac{R_{g2}}{R_{g1}} \dots \dots \dots (11)$$

It follows that the resistance R_{g2} should be made as high as possible, and that, once this has been done, a transformer should be chosen with a transformation ratio about equal to $\sqrt{\frac{R_{g2}}{R_{g1}}}$. It is not always possible adequately to satisfy this latter condition, as will be more fully explained later. The resistance R_{g2} is made high by preventing the potential of the grid of Tube 2 from ever becoming positive, for, in this case, the grid-filament resistance is theoretically infinite; this is accomplished by keeping the grid at a negative potential by a suitably connected battery, or by any of the circuit arrangements already explained on page 827. Practically, on account of gas in the tube and the leakage from grid to filament outside of the tube, the grid-filament resistance, while very large, is at the most of the order of one million to 10 million ohms, and may in some cases be as low as a few hundred thousand ohms. For the ideal value of n^2 the ratio $\frac{E_{g2}}{E_{g1}}$ would be found by substituting (11) in (10); thus:

$$\frac{E_{g2}}{E_{g1}} = \mu_0 \frac{n}{2} \dots \dots \dots (12)$$

If the tubes used for the various stages of amplification are similar, which is almost always the case, the transformers may have the same ratio throughout.

The results indicated by Eqs. (11) and (12) have been obtained on the basis of ideal transformers having neither leakage inductance nor coil resistance and requiring no magnetizing current. The effect of all of these in an actual transformer would be such as to alter the best value of the transformation ratio, and, more than this, to diminish the ideal ratio E_{g2}/E_{g1} as given by Eq. (12). The leakage inductance and coil resistance of the transformer can be made quite small and negligible as compared with the resistance R_{g2} , and their effect will, therefore, be but small. On the other hand, it is very important to make the magnetizing current very small, or, in other words, to make the no-load reactance of

the transformer primary very high. This will be made clearer by a study of the diagram Fig. 9, which is similar to Fig. 8, with the exception of the introduction of X_0 in multiple with R_{p1}/n^2 , where: X_0 = reactance of transformer primary at no load.

A resistance should, in the above diagram, be inserted in series with X_0 to represent the core losses, but we have omitted it for the sake of simplicity and also because in such transformers the core losses are made negligibly small.

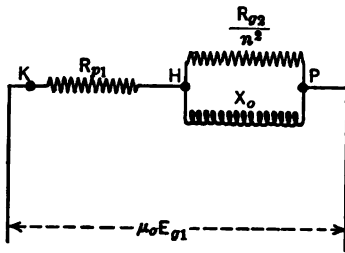

FIG. 9.—In order to take care of the magnetizing current of the transformer the diagram of Fig. 8 must be changed as above, the value of X_0 being equal to the primary reactance with secondary open.

The diagram shows that X_0 is in multiple with R_{p2}/n^2 and therefore diminishes the equivalent impedance of the circuit $H-P$; if, then, X_0 were very low the voltage drop across $H-P$ and, therefore the secondary voltage (E_{g2}) would be small. It is important, then, to make X_0 as high as possible, or, in other words the primary must have a very large number of turns. There is a point, however, beyond which it is uneconomical to increase

the value of X_0 , since the gain in amplification is too small to make it worth while. To show this we have worked out the theoretical curves of Fig. 10, after having assumed the following:

$$\mu_0 = 6,$$

$$R_p = 10,000.$$

For R_{p1} two different values were chosen, i.e.:

$$R_{p1} = 250,000 \text{ ohms and } R_{p1} = 1,000,000 \text{ ohms.}$$

For R_{p1} of 250,000 ohms the best transformer ratio for an ideal transformer is found, from Formula (11), to be: $\sqrt{\frac{250,000}{10,000}} = 5$, and, similarly

for R_{p1} of 1,000,000 the best transformer ratio would be $\sqrt{\frac{1,000,000}{10,000}} = 10$.

From Formula (12) we have:

$$\text{Maximum possible value of } \frac{E_{g2}}{E_{g1}} \text{ for } R_{p1} \text{ of } 250,000 = 6 \times \frac{1}{3} = 15.$$

$$\text{Maximum possible value of } \frac{E_{g2}}{E_{g1}} \text{ for } R_{p1} \text{ of } 1,000,000 = 6 \times \frac{1}{2} = 30.$$

The points on the curves have been plotted by assuming different values of X_0 and then obtaining the voltage across $H-P$ and also the secondary voltage E_{o_2} , after which E_{o_2}/E_{o_1} was computed. The assumption was made that the transformer had no leakage inductance, no coil resistances, and no core losses. Curves were drawn for two different

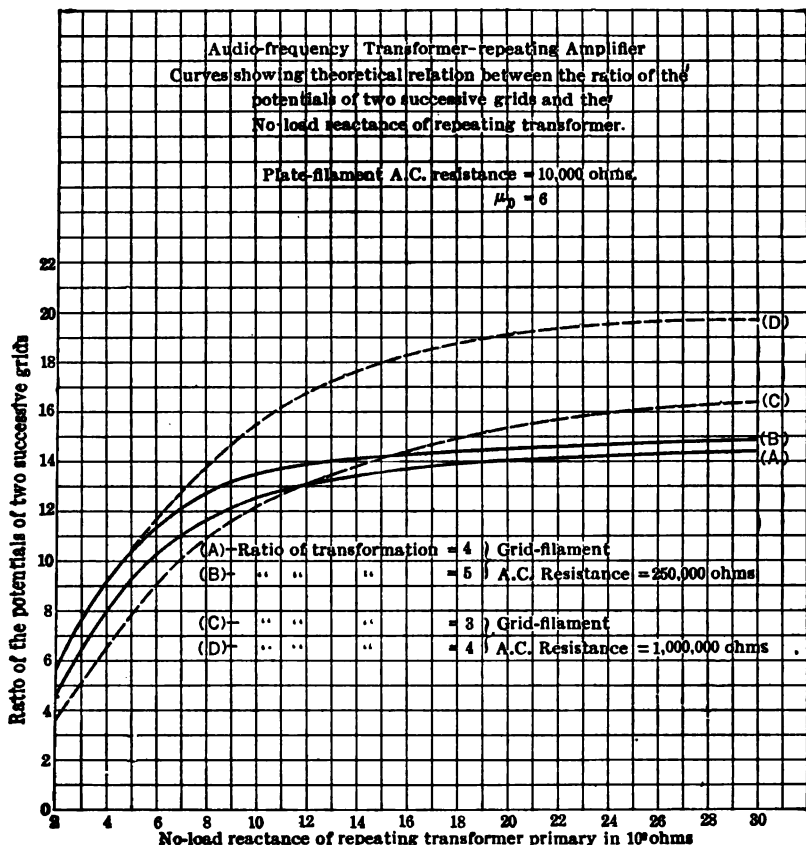

Fig. 10.—Calculated values of voltage amplification using transformers of different ratios and two different values of input circuit resistance of the second tube. The curves show the effect of varying the no-load reactance of the primary of the transformer abscisse being no-load reactance in thousand ohms.

ratios of transformation, i.e., 4 and 5 for R_{o_1} of 250,000 and 3 and 4 for R_{o_1} of 1,000,000 ohms. They show:

1st. That for low values of X_0 the ratio E_{o_2}/E_{o_1} may be very small, even smaller than the amplifying factor of the tube, which is in this case . Thus, a transformer with low no-load reactance might make the result of two tubes no better, or even worse, than for one tube alone.

2d. That for R_{p_1} of 10^6 ohms the ratio of E_{s_1}/E_{p_1} is larger than for R_{p_1} of 250,000 ohms, for the same transformer ratio, even though the value of n used for R_{p_1} of 250,000 ohms is much nearer the ideal value than for R_{p_1} of 10^6 ohms.

3d. Beyond certain values of X_0 the ratio E_{s_1}/E_{p_1} does not increase much with increase of X_0 . Not only is it of no advantage to increase the reactance X_0 above a certain amount, but it is actually disadvantageous. The X_0 is, of course, increased by increasing the cross-section of the core or the number of turns in the primary winding. The former of these expedients is objectionable because it increases the space requirements. As regards increasing the number of primary turns, it must be noted that, if this is done, the secondary turns must be proportionately increased if the ratio of transformation, n , is to be constant. Now, the higher the number of transformer turns the higher become the internal resistance and leakage reactance of the transformer, which have so far been neglected in our discussion.

A high internal transformer impedance may produce a large internal drop due to the "load" attached to secondary, i.e., the grid-filament resistance and reactance of the tube into which the transformer is repeating, and also the *internal distributed capacity of the secondary winding itself*; the final result would be that the voltage applied to the grid-filament might be far less than that calculated on the basis of negligible internal transformer drop. This may be summed up by stating that, for a given frequency, the higher the number of turns used the more does the ratio of terminal voltages (secondary to primary) depart from the turn ratio n , being only a fractional part of n . In fact, it is possible to increase the transformer turns to such an extent (more especially if the ratio be high, say: 10 to 1), that the terminal voltage of the secondary (when used in the tube circuit) is *less than the voltage impressed upon the primary winding*. The above phenomenon may take place if the number of turns is kept constant and the frequency raised. In practice the value of X_0 for an amplifier to be used at constant audio-frequency is made equal to about once or twice the value of the plate-filament a.c. resistance.

4th. The higher the ratio of transformation the greater the amplification. In connection with this it will be noted, however, that a point may be reached beyond which it is uneconomical to increase the ratio, since the gain in amplification is too small, as for example in the case of curves *A* and *B* for transformer ratios of 4 and 5 respectively. As a matter of fact if we consider that, for a constant number of primary turns, the increase in ratio is obtained by increasing the number of secondary turns and that simultaneously the internal impedance of the transformer and effect of the distributed capacity of the secondary are increased, it will be apparent that, due to the large internal drop, the voltage across the sec-

ondary may be smaller for a high than for a low ratio of transformation. This effect has already been pointed out in connection with the value of X_0 and plays such an important part in connection with the trans-

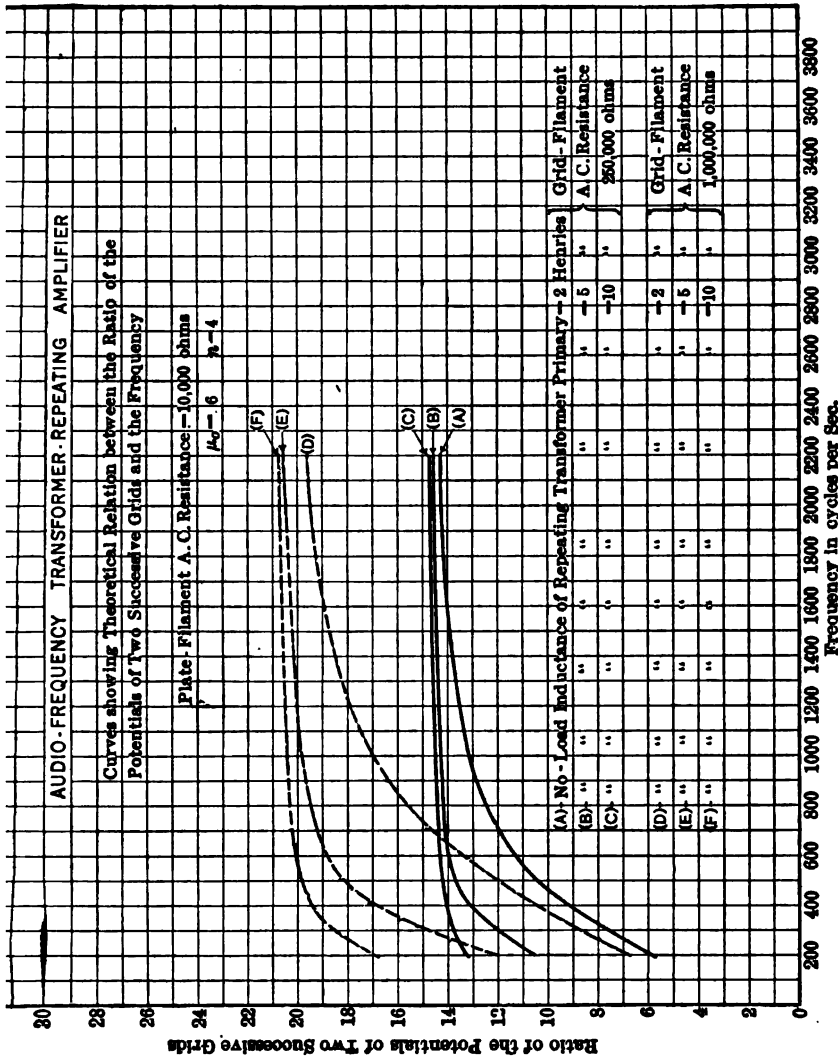

Fig. 11.—Effect of frequency on amplifying power of tube and transformer, for two different values of input resistances of the second tube.

formation ratio that it has been found advisable, in practice, to keep the value of this ratio below about 4 or 5.

By means of the curves of Fig. 10 we have plotted another set of curves which is given as Fig. 11, and which shows how the frequency affects the

ratio of E_{g2}/E_{g1} for different values of no-load inductance of the primary of the repeating transformer. The values chosen for this inductance are 2, 5, 10 henries. The curves bring out the following very important facts:

1st. For every value of inductance there is a frequency, below which the amplifying action of the tube and transformer varies very widely, and above which the amplifying action varies but little.

2d. If the frequency is too low the amplifying action may be very poor; hence an amplifier may work very well on comparatively high audio-frequency and fail to work on lower frequencies.

3d. If the amplifier is to be used over a wide range of frequencies, as in the case of amplification of telephone or radiophone currents, then it is extremely important to choose a value of transformer inductance such that the amplifying action will be nearly the same over the entire range of frequencies, otherwise the low-frequency components would suffer, and speech would thereby be distorted. Thus, assuming, as is generally done, that the speech frequencies vary over an average range of 300 to 2000 or more cycles per second, an inductance of 10 henries would, in our case, be sufficiently high to amplify all frequencies equally well, provided that the internal leakage reactance and capacity do not come into the question; any higher inductance than this would not produce sufficient gain either in amplification or in equality of amplification for different frequencies to warrant its use, in fact due to its high internal drop it would probably make the amplification of the higher frequencies poorer.

4th. Much greater amplification is obtained at nearly all frequencies and nearly all values of no-load primary inductance for R_p of 1,000,000 ohms than for R_p of 250,000 ohms.

Our analysis shows that, while theoretically, the ratio of transformation should be equal to $\sqrt{R_p/R_g}$, and the value of X_0 should be very large, yet, practically, the transformation ratio should not be made much larger than 4 or 5 and X_0 should not be much larger than once or twice the plate-filament resistance. Where the amplifier is to be used for telephone currents it is important that the primary no-load inductance of the repeating transformer be chosen high. In every case a large grid-filament resistance is effective in producing large amplifications, and this condition should always be striven for by preventing the grid from assuming a positive potential.

In the case of the first transformer T (see Fig. 6) it may be shown by a method similar to that used for the other transformers that the ideal ratio of transformation is given by:

$$S = \sqrt{\frac{R_p}{R}} \dots \dots \dots (15)$$

where S = ratio of secondary to primary voltage for transformer T ;
 R = Resistance connected in series with the primary of transformer T .

The resistance R may be that of the plate-filament circuit of some other tube or of a telephone line or anything else which may be in series with the transformer primary.

Again, as in the case of the other transformers, the no-load inductance of the primary should be high, and the ratio S should not be made so high as to permit the internal capacity of the transformer to have much effect.

Construction of Transformers for Low-frequency Amplifiers.—In order to make the no-load reactance of the primary of the transformer high it should be constructed with a good quality of iron suffering but small losses and having high permeability. The flux leakage of the primary and secondary coils should be very low.

The main difficulty in connection with a transformer of this type is to so arrange the windings that they will have as little distributed capacity as possible. In view of the necessity of saving space the large reactances of the coils are obtained by the use of a very large number of layers of fine wire placed on a comparatively small core; hence the difficulty of making the capacity between layers small. Ordinarily sheets of insulation are placed between adjacent layers so as to make the distance larger than would otherwise be the case, and thus diminishing the capacity.

It will be readily understood that a large capacity connected either across the secondary or across the primary or both lowers the no-load impedance of the transformer and reduces amplification. As long as the internal capacity of the transformer is small compared to the capacity of the input circuit to which the secondary is connected, it will be of little importance in determining the behavior of the amplifier.

Impedance of Telephone Receivers.—The receivers used in the plate circuit of the last tube of the amplifier should be suitably chosen. The impedance of a telephone receiver is made up of the following four components:

- 1st. The static reactance.
- 2d. The static effective resistance.
- 3d. The motional reactance.
- 4th The motional resistance.

The first two components are due to the constants of the electric and magnetic circuits of the receiver and the losses taking place therein and

are the effective reactance and resistance measured with the diaphragm "locked."

The motional reactance and resistance are produced by the motion of the diaphragm and are to be added to the static reactance and resistance respectively. It is plain that the motional resistance is the resist-

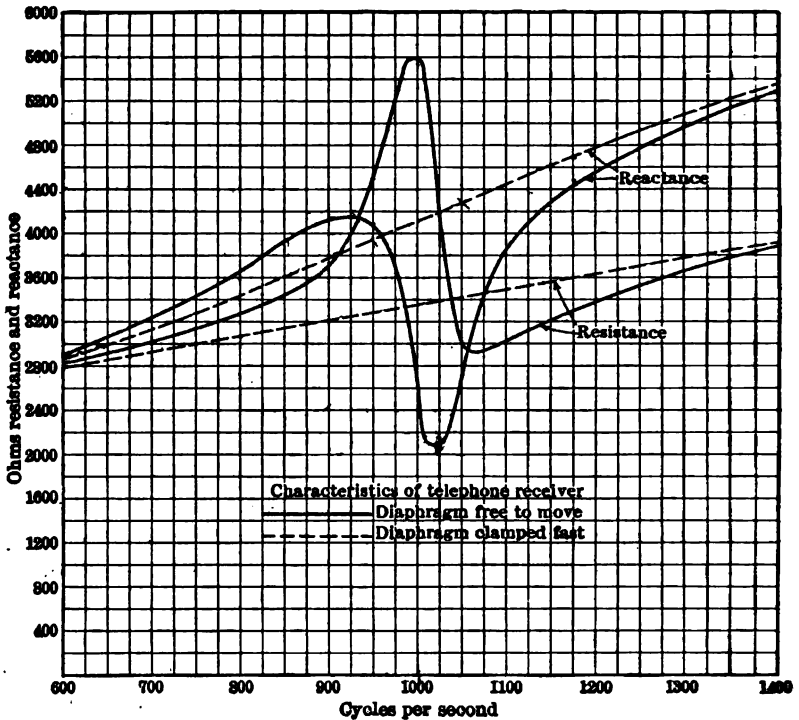

FIG. 12.—Resistance and reactance of such a receiver as is used in radio work as a function of the frequency; one set of curves gives the characteristics with diaphragm free to move and the other with it clamped tight.

ance equivalent of the power expended in moving the diaphragm to and fro part of which is useful in producing sound; in other words, for a certain receiver, the greater the motional resistance the greater will be the receiver response to a certain value of incoming alternating current. The value of this resistance varies with the frequency and is a maximum at about 900 to 1000 cycles per second. Curves are given in Fig. 12, showing the relation between frequency and resistance and reactance of a receiver with the diaphragm locked and with the diaphragm vibrating.¹ In view

¹ It must be pointed out that where the motional resistance is negative, the diaphragm is not acting like a generator, giving off electric power due to its motion; the

of the many components of the impedance of a receiver and their variation with the frequency it is difficult to lay down any set rules for the choice of a receiver. We may, however, simplify matters by first assuming that we are dealing with a receiver having nothing but motional resistance.

- Let R_m = motional resistance of receiver;
 R_p = plate-filament a.c. resistance of last tube;
 $\mu_0 E_g$ = effective value of alternating voltage impressed upon the plate circuit of the last tube;
 I_p = effective value of the alternating current component in the plate circuit of the last tube;
 P_m = power expended in R_m .

Then

$$I_p = \frac{\mu_0 E_g}{R_m + R_p},$$

and

$$P_m = I_p^2 R_m = \frac{\mu_0^2 E_g^2}{(R_m + R_p)^2} R_m \dots \dots \dots (14)$$

For maximum response in the receivers the power (P_m) expended in the motional resistance should be a maximum, and since the expression of Eq. (14) is a maximum when $R_m = R_p$, we conclude that if the receiver had nothing but motional resistance then maximum response would be obtained by making the motional resistance equal to the plate-filament a.c. resistance of the last tube.

In the case of a practical receiver containing motional and static resistance and reactance it is apparent that the larger we make the number of turns of copper wire the more we increase all the components of the impedance, including the motional resistance, and the greater is likely to be the receiver response. It is, however, difficult to determine theoretically how far we should go on increasing the number of turns and the total impedance. In practice, a receiver is generally chosen whose total impedance is about equal to the a.c. resistance from plate to filament.

Connections of Transformer-repeating Low-frequency Amplifiers for the Reception of Damped and of Undamped Waves.—The diagram of Fig. 6, page 830, shows in a schematic manner a low frequency transformer repeating amplifier without any connections to any receiving apparatus. Fig. 13 shows how such an amplifier would be connected to another tube for the reception of damped waves or of radiophone

negative motional resistance merely signifies that the diaphragm in motion (in the right motional phase) absorbs less power as eddy currents and hysteresis than if it is locked and so unable to move.

messages. Fig. 14 shows a crystal detector receiver for damped waves and the manner in which it would be attached to the amplifier, while

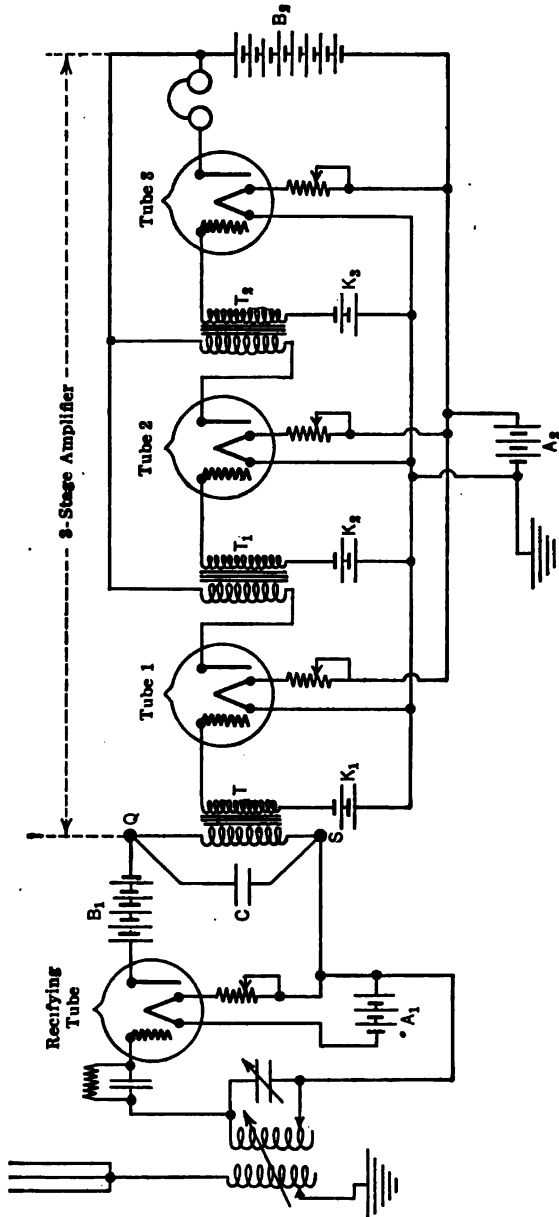

Fig. 13.—Connection of tube detector receiving set to the amplifier.

Fig. 15 shows an autodyne tube receiver for undamped waves and the manner in which it would be connected to the amplifier. Considering

Fig. 13 it will be noted that the rectifying tube is connected in the standard manner already discussed in Chapter VI, page 451, with a grid condenser and leak resistance, and that,

in this case, the telephone receivers, which would ordinarily be connected to the points *Q* and *S*, have been replaced by the amplifier. The condenser *C* is of a fairly large capacity (5000 μmf or more) and is used for the purpose of carrying whatever high-frequency currents flow in the plate circuit of the rectifying tube; these high-frequency currents flow readily through the low impedance which the condenser *C* has at high-frequency, while,

on the other hand, the audio-frequency currents which are to be amplified take the path of the primary of the transformer *T*. As a matter of fact the repeating transformers such as *T*, *T*₁, *T*₂, have such a high distributed capacity, on account of

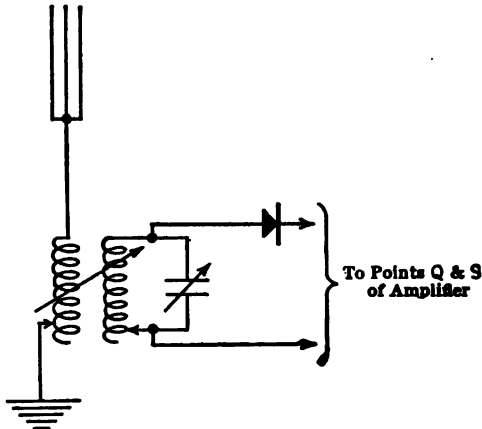

FIG. 14.—How a crystal detector set would be connected to the amplifier.

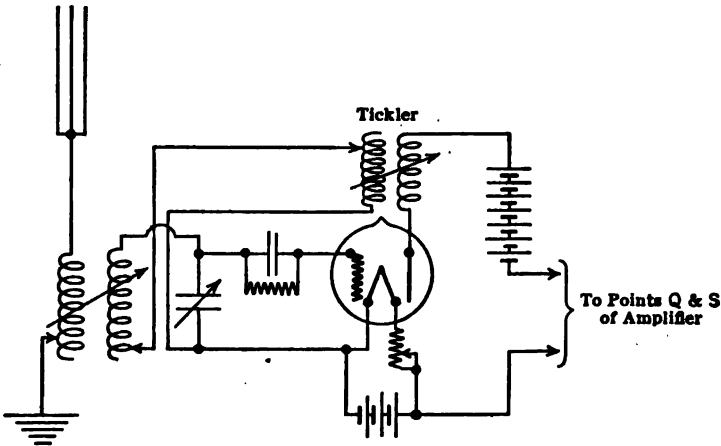

FIG. 15.—How an autodyne tube receiving continuous wave signals would be connected to the amplifier.

the very large number of layers of wire enclosed in a small space, that the by-pass capacity *C* may often be dispensed with, in which case the distributed capacity of transformer *T* carries the high-frequency currents.

The amplifier shown in Fig. 13 has batteries K_1 , K_2 , K_3 in series with the grids for the purpose of keeping them at an average negative potential; it will also be noted that a single battery (A_2) is being used for the filaments of all the amplifying tubes, and that the battery B_2 feeds the plates of all the amplifying tubes. Instead of using the grid batteries K_1 , K_2 , K_3 the lower ends of the secondaries of the repeating transformers may be connected to the filament battery circuit at a point of suitable negative potential. This has been discussed on page 827 and is exemplified in the amplifier circuit of Fig. 16, page 845. Figs. 14 and 15 hardly need any explanation and show in every case that the amplifier is connected in place of the telephone receivers.

Transformer-repeating Amplifiers for High Frequencies.—These are similar to the amplifiers for audio frequency with the exception of different electrical constants for the transformers, made necessary by the use of radio frequencies. A diagram is given in Fig. 16 showing a three-stage high-frequency transformer-amplifier connected for the reception of undamped waves. It will be noted that the grid of the first amplifying tube is connected directly across the receiving tuning condenser. Q and S are the input terminals of the amplifier while Q_1 and S_1 are the output terminals; the latter are shown connected to an autodyne rectifying tube, and the telephone receivers are placed in the plate circuit of the rectifying tube. The grids are maintained at an average negative potential by making use of proper resistances in series with the negative sides of the filaments. If grid batteries should be used instead they should be connected on the lower side of the secondaries of the repeating transformers; if connected next to the grid they will increase the free capacity of the grid connection and thus reduce to some extent the voltage impressed on the grid itself.

This type of amplifier is not a very efficient one, and, in fact, we might say that it is almost impossible to construct an efficient amplifier for very high frequencies. We will discuss the main features and difficulties encountered in this amplifier, and will find later that these difficulties exist in all types of high-frequency amplifiers.

The repeating transformers T_1 , T_2 , T_3 are generally constructed without any iron, in order to prevent the excessive eddy current and hysteresis losses which would take place at radio frequencies.

The optimum electrical constants of the transformers cannot be derived on the same basis as for the repeating transformers of the low-frequency amplifiers for the reason that the high-frequency transformers do not approach, even to a small extent, the ideal transformer without leakage. Consider the plate and grid circuits of two adjacent amplifying tubes as represented in Fig. 17. Assume, for the sake of simplicity, that the grid takes no current, or, in other words that its resistance is infinite. We will

Let

- μ_0 = amplifying constant of first tube;
- E_{g1} = alternating grid voltage of 1st tube;
- E_{g2} = alternating grid voltage of 2d tube;
- I_p = alternating component of plate current of 1st tube;
- ω = angular velocity of radio frequency currents;
- M = mutual inductance between L_1 and L_2 ;
- k = coefficient of coupling between L_1 and $L_2 = \frac{M}{\sqrt{L_1 L_2}}$

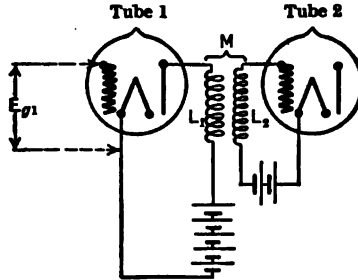

FIG. 17.—Circuit detail of the high-frequency transformer.

Since the circuit of L_2 is assumed of infinite impedance it follows that E_{g2} is equal to the e.m.f. induced in L_2 , or

$$E_{g2} = \omega M I_p = \omega I_p k \sqrt{L_1 L_2}$$

but

$$I_p = \frac{\mu_0 E_{g1}}{\sqrt{(\omega^2 L_1^2 + R_p^2)}}$$

therefore

$$E_{g2} = \frac{\mu_0 \omega E_{g1} k \sqrt{L_1 L_2}}{\sqrt{(\omega^2 L_1^2 + R_p^2)}}$$

and

$$\frac{E_{g2}}{E_{g1}} = \frac{\mu_0 \omega k \sqrt{L_1 L_2}}{\sqrt{(\omega^2 L_1^2 + R_p^2)}} \dots \dots \dots (15)$$

The ratio E_{g2}/E_{g1} varies directly with k and $\sqrt{L_2}$ but it varies in a complex manner with L_1 . If all other quantities are kept constant and L_1 only varied, it may be shown that E_{g2}/E_{g1} is a maximum when

$$\omega L_1 = R_p \dots \dots \dots (16)$$

If

$$R_p = 10,000 \text{ ohms (previously assumed value)}$$

and

$$\omega = 3 \times 10^6 \text{ (about 600 meters wave-length)}$$

then, for maximum value of E_{g2}/E_{g1} ,

$$L_1 = \frac{10,000 \times 10^6}{3 \times 10^6} = 3300 \text{ microhenries.}$$

An inductance of 3300 microhenries cannot be constructed to have an internal capacity which is negligible at a frequency of 500,000 cycles per second, especially if the space requirements prohibit much space between layers. Even if such internal capacity is very small, say, 20 $\mu\mu\text{f}$, the natural wave-length of the coil would be given by:

$$\text{natural wave-length of coil } L_1 = 1.885 \times \sqrt{3300 \times 20} = 485 \text{ meters.}$$

In other words, the coil whose inductance is L_1 may have a natural wave-length within the range of wave-lengths of the signals received by the amplifier. It follows that when the wave-length of the incoming signal is equal to the natural wave-length of the coil L_1 , then the coil will act like a high resistance: this equivalent high resistance of the coil, connected in series with the smaller plate resistance, R_p , will cause the changing $\mu_0 E_{\sigma_1}$ to be impressed practically wholly upon the coil L_1 , and hence the repeating action from L_1 into L_2 will be very good at the wave-length under consideration. For other wave-lengths than that equal to the natural wave-length of L_1 the repeating action will not be so good and may be very poor. This is, of course, objectionable.

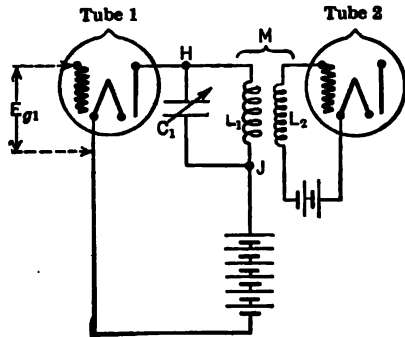

FIG. 18.—When receiving fixed wave-lengths the use of a condenser C_1 in parallel with a low-inductance primary, is preferable to a primary which by itself has suitably high reactance.

The remedy to the above may be found in making L_1 small and placing a tuning condenser in multiple with it, as shown in Fig. 18. The tuning condenser C_1 would be adjusted so that L_1-C_1 are tuned to the incoming frequency. When this is done the resistance between the points H and J would be so large that the resistance of the plate to filament of the first tube may be neglected. The results will be the same as if the voltage $\mu_0 E_{\sigma_1}$ were applied directly across $H-J$ without any drop in the plate circuit. Assume this to be the case and let:

I_1 = alternating component of current in L_1 ;

$$I_1 = \frac{\mu_0 E_{\sigma_1}}{\omega L_1};$$

$$E_{\sigma_2} = \omega M I_1 = \omega I_1 k \sqrt{L_1 L_2} = \frac{\omega k \mu_0 E_{\sigma_1} \sqrt{L_1 L_2}}{\omega L_1}$$

$$= \frac{\mu_0 k E_{\sigma_1} \sqrt{L_2}}{\sqrt{L_1}},$$

and

$$\frac{E_{g_2}}{E_{g_1}} = \frac{\mu_0 k \sqrt{L_2}}{\sqrt{L_1}} \dots \dots \dots (17)$$

This last equation shows that when L_1-C_1 is tuned to the incoming frequency the ratio E_{g_2}/E_{g_1} varies inversely as $\sqrt{L_1}$; hence it is advisable to make L_1 very small, a condition which is very desirable, since then the distributed capacity is negligible. There is, however, a limit to decreasing L_1 , in view of the fact that the resistance of a multiple resonating circuit such as L_1-C_1 will, after decreasing L_1 below a certain value, decrease and will thus cause a much lower voltage to be applied across the points $H-J$ of Fig. 18. This effect can be calculated from Eq. (50), page 72, from which it may be seen that the effective resistance of the parallel circuit, at resonance, depends upon the ratio of L to R ; the smaller L is made the lower in the ratio L/R unless large well-stranded conductors are used.

As regards L_2 , it should be made large, yet if it be so made its distributed capacity may be such as to practically short-circuit the grid-filament of the second tube and make the ratio E_{g_2}/E_{g_1} practically zero. Hence, it is advisable to keep L_2 as small as is consistent with reasonable amplification. We will illustrate by means of the following example:

Take

$$\begin{aligned} \mu_0 &= 6; \\ k &= 0.3; \\ L_1 &= 36 \mu h; \\ L_2 &= 256 \mu H. \end{aligned}$$

Then

$$\frac{E_{g_2}}{E_{g_1}} = \frac{6 \times 0.3 \times \sqrt{256}}{\sqrt{36}} = 4.8,$$

which is a small value as compared with 8.5 to 9.5 for audio-frequency amplifier.

Of course we could increase L_2 above 256, but, in so doing, its distributed capacity would begin to affect the grid voltage adversely and nothing would be gained by the increase in L_2 .

The effect of the grid-filament capacity must now be considered. This capacity is comparatively small under static conditions but, as shown on page 432, Chapter VI, it increases very much under the conditions present in amplifiers; of course the reactance of this capacity is in parallel with the grid-filament circuit and causes the voltage across the grid to fall to a small value, in spite of all the precautions which we may have been taken in designing the repeating transformer. As a matter of fact it is shown in Chapter VI that the higher the alternating voltage produced

at the output terminals of the tube the lower becomes the capacity reactance of the input circuit, or, in other words, the better the repeating transformer the poorer may the amplification be. Thus the capacity of the input circuit of an amplifying tube, may be 50 to 75 $\mu\mu\text{f}$. Assuming a value of 50 $\mu\mu\text{f}$ the reactance of this capacity at 600 meters would be only 6400 ohms!

This is the most important difficulty encountered in the design and construction of all high-frequency amplifiers, a difficulty which makes such amplifiers, especially for short wave-lengths, very difficult to construct. The only remedy is to reduce the capacity of the input circuit or, in other words, to make the area of the grid as small as feasible, and keep the wires connecting to the grid as far from the other wires of the tube as possible and use a tube having a low μ_0 . Some very small tubes have been built for high-frequency amplifiers with these ideas incorporated.¹ The μ_0 of such tubes is generally low, probably not more than 3.

In case tuned plate circuits are used for a high-frequency amplifier it is evident that unless all the tuning condensers are controlled by one handle the adjustment of the amplifier for signals of various frequencies would be tedious and difficult.

Resistance-repeating Amplifiers.—We will first discuss this type of amplifier relative to audio-frequency amplification. The diagram of Fig. 19 shows such an amplifier for three stages. The incoming signal voltage is applied to the points QS and is caused to affect the grid of Tube 1 through the means of the high resistance R . The grid and filament of Tube 1 are connected across the resistance R through the comparatively large condenser C_1 ; a leak resistance r_1 is connected from the grid to the filament. The purpose of the leak resistance and of the condenser C_1 will be explained later, but it will be presently understood that any variations of potential difference across R will be impressed upon the input circuit of Tube 1 with the exception of any drop of potential which may take place in the condenser C_1 .

The variations of the grid potential of Tube 1 will cause a corresponding variation of the plate current in this tube, and hence a varying difference of potential will exist across the high resistance R_1 . Since the point o is at constant potential it is plain that the potential difference between the points k and o will be varied and, as the battery resistance is comparatively low, the variation of this potential difference must necessarily be very nearly the same as that across R_1 .

The grid and filament of Tube 2 are connected across k and o through the comparatively large condenser C_2 , and, therefore, any variation in the potential difference across k and o will be impressed upon the grid

¹ Such a tube is shown at O in Fig. 21 of Chapter VI, page 389.

of Tube 2, or, in other words the signal will be repeated into the second tube by means of the repeating resistance R_1 .

In a similar manner the signal will be repeated from Tube 2 to 3, where it will be picked up on the receivers. The purpose of the grid

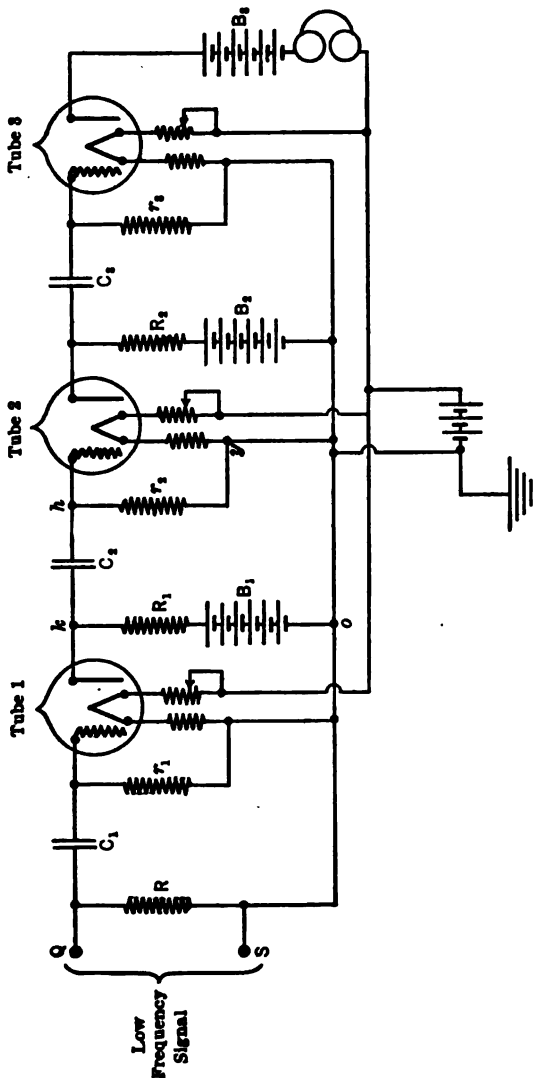

Fig. 19.—A resistance-repeating amplifier of three stages.

condensers C_2 and C_3 is to insulate the grids of Tubes 2 and 3 respectively from the batteries B_1 and B_2 . Thus, if condenser C_2 were removed it is plain that the grid of Tube 2 would then be connected to battery B_1 through the resistance R_1 , and the battery would impress such a high positive potential upon the grid as to probably spoil the tube. A similar reasoning applies to the case of grid condenser C_1 in so far as it insulates the grid of tube 1 from any high direct electromotive force which may be to the left of the points QS ; sometimes, as will be shown later, it is possible to dispense with the grid condenser C_1 and the resistances r_1 and R for the first tube.

As regards the leak resistances r_1 , r_2 , r_3 they are made neces-

sary by the use of the insulating grid condensers C_1 , C_2 , and C_3 . It has already been found in Chapter VI, page 410, that, when a condenser is connected in series with the grid, if the grid is very highly insulated, the operation of the tube is very uncertain. The accumulation of electrons

in the grid generally forces it to assume a negative potential of one or two volts, this amount depending upon filament current, etc. If a sudden pulse of e.m.f. (such as given by a "stray") is impressed on the grid it probably will accumulate sufficient electrons to force the plate current to zero and *this accumulated charge of electrons in the grid has no way of escaping.*

Of course as long as the plate current of one tube is zero the amplifier is "dead"; it is said to be "paralyzed," or "blocked." The grid of a triode should never be left "free" or "floating," as the behavior of the tube will then always be erratic. As to just how much leak resistance is required from grid to ground to make the tube stable depends upon the size of the tube and degree to which it has been pumped; it may be anything between 10^5 and 10^7 ohms for the small tubes used for amplifiers.

Suitable Values of Repeating Resistances.—Confining our attention to the repeating resistance from tube 1 to tube 2, i.e. R_1 (Fig. 19) let:

E_{g_1} = effective value of alternating voltage impressed upon the grid of first tube;

E_{g_2} = effective value of alternating voltage impressed upon the grid of second tube;

I_p = effective value of alternating component of plate current of Tube 1;

μ_0 = amplifying constant of Tube 1;

R_p = a.c. resistance of plate-filament for first tube.

If we assume that the impedance of the circuit $k-C_2-h-g-o$ is very high as compared with the resistance R_1 , then the impedance between the points k and o will be made up practically entirely of the resistance R_1 , hence we may write:

$$I_p = \frac{\mu_0 E_{g_1}}{R_p + R_1} \dots \dots \dots (18)$$

gain, assuming that the reactance C_2 is very low as compared with that of the grid-filament of tube 2, there will be a negligible drop of potential over C_2 and the voltage of the grid to filament for Tube 2 will be given by:

$$E_{g_2} = I_p R_1 = \frac{\mu_0 E_{g_1} R_1}{R_p + R_1} \dots \dots \dots (19)$$

and

$$\frac{E_{g_2}}{E_{g_1}} = \frac{\mu_0 R_1}{R_p + R_1} \dots \dots \dots (20)$$

Eq. (19) shows that the ratio E_{g_2}/E_{g_1} increases continuously with increase of R_1 and it approaches a maximum which will be reached when R_1 is so large that R_p may be neglected; this maximum will be given by:

$$\text{Maximum possible value of } \frac{E_{g_2}}{E_{g_1}} = \mu_0. \dots \dots \dots (21)$$

This result is to be compared with that given by Eq. (12) and applying to the case of a repeating transformer amplifier, for which:

$$\text{Maximum possible } \frac{E_{g_2}}{E_{g_1}} = \frac{n}{\mu_0 2} \dots \dots \dots (21a)$$

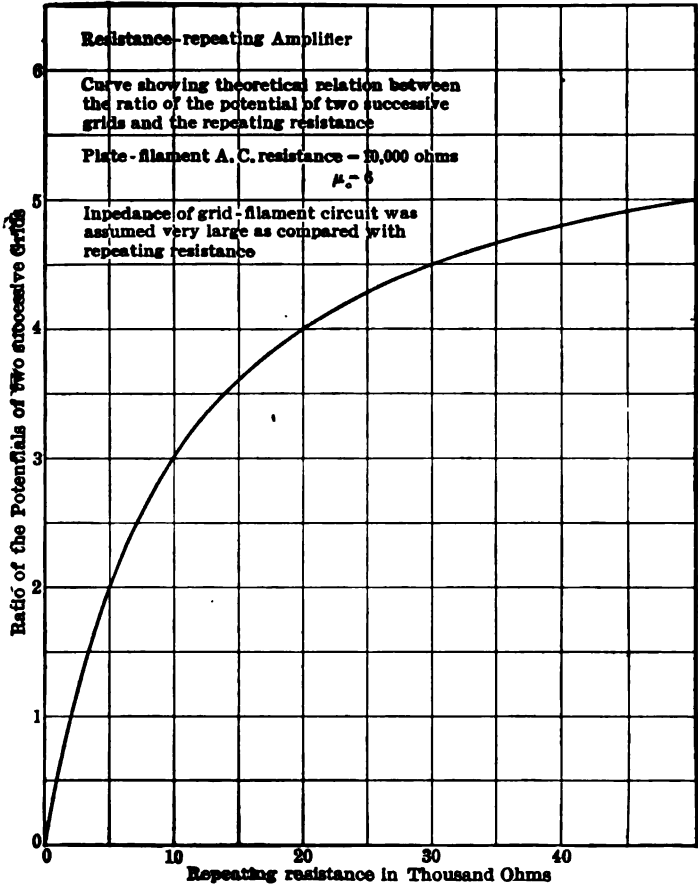

FIG. 20.—Variation in the amplifying power of a resistance-repeating tube as the value of the external resistance used in the plate circuit is varied.

In order to study more fully the relation expressed by Eq. (20) we have plotted curve, Fig. 20, for which:

$$\mu_0 = 6$$

$$R_p = 10,000.$$

The curve shows that it is hardly worth while to increase R_1 beyond about 30,000 ohms for this particular tube, for the gain in E_{g_2}/E_{g_1} is

thereafter too small for even very large increases of R_1 . Furthermore, it must not be forgotten that the insertion of a resistance in series with the plate requires a corresponding increase in the voltage of the B battery as previously pointed out. As a matter of fact such a tube would probably not be used with more than 20,000 ohms in the plate circuit. This would require a B battery of twice the voltage required if there was no IR drop in the external plate circuit and will give a voltage amplification of $2/3$ of μ_0 (in the above case, 4).

As regards the first repeating resistance R it may be shown that it should be very high as compared with the resistance in series with it; the latter may be the plate-filament resistance of another tube or the resistance of a telephone line, etc.

The repeating resistances used are made up in units of small dimensions, approximately $\frac{1}{4}$ inch in diameter and 2 to 3 inches in length. There are three general types in use: Type 1 consists of a tube of insulating material wound with high resistance wire and coated with enamel; it is made up in units up to about 5000 ohms. Type 2 consists of a tube of insulating material wound with a few turns of carbon filament containing a large percentage of clay and thus having a very high resistance; it is made up in units up to 50,000 ohms. Type 3 consists of an evacuated glass tube upon the inside walls of which there is "sputtered" a film of tungsten which is very thin and therefore of very high resistance; it is made up in units up to 2,000,000 ohms.

In every case it must be kept in mind that no matter what type of resistance is used for repeating purposes it must have a current-carrying capacity such as will enable it to carry the average current flowing in the plate circuit of the tube wherein it is to be connected without overheating. Thus, in the case of a tube whose average plate current is 4 milliamperes a repeating resistance of 50,000 ohms should be able to dissipate 0.8 watt without overheating.

The repeating resistance should have negligible distributed capacity, or, this would lower the value of its impedance and cause a reduction in the amplification.

Another important point regarding the resistances used for repeating comes up in connection with internal noises in an amplifier. It seems that some of the high resistance units are "microphonic," that is, their resistance continually varies by a very small amount. It will be at once evident that such a resistance will give rise to noises in the amplifier, specially if the microphonic resistance is in one of the first stages of the amplifier. In general the higher the resistance the more likely is it to be microphonic.

Suitable Value of Grid Condenser.—The grid condenser must have a small reactance as compared with the circuit from grid to filament, which

circuit consists of the leak resistance and the capacity and resistance of grid to filament; the point to keep in mind is that the variation of potential difference existing between the points k and o (see Fig. 19) should be made to suffer but a negligible drop over the reactance of the grid condenser, so that it may be applied very nearly in its entirety to the grid-filament circuit. For audio-frequencies the reactance of the capacity of the grid to filament is very high, i.e., one to two million ohms and does not appreciably affect the impedance between the grid and filament, which is almost entirely made up of the leak resistance and the internal grid to filament resistance in multiple, which make up a resistance of the order of 200,000 ohms. In this case the grid condenser may be allowed to have a reactance of 50,000 ohms without seriously affecting the grid voltage, or, in other words, for, say, 1000 cycles per sec. the capacity of the grid condenser may be about $\frac{1}{50,000} \times 6280$ or, roughly, 3000 $\mu\mu\text{f}$.

If, however, the amplifier is used for high frequencies,¹ say $\lambda = 600$ meters, then the impedance of grid to filament is made up almost wholly of the grid-filament capacity reactance, which, for the amplifying tubes generally used, is of the order of about 6000 ohms, hence the grid condenser reactance should be of the order of about 1500 ohms or less; its capacity may then be as low as 200 $\mu\mu\text{f}$ without decreasing the value of E_n more than 20 per cent. It is then apparent that smaller values of grid condenser capacity may be used at high than at low frequencies. In any case it is not advisable to use any larger capacity than just necessary, for in doing so, the amplifier is too likely to block for longer periods of time than necessary. If a pulse of e.m.f. is impressed on the amplifier all of these repeating condensers will become charged and so cut the various plate currents to probably zero. Before the amplifier can function the plate currents must come back to normal value and this requires that all these condensers (C_1, C_2, C_3 , etc.) discharge themselves. The time required for discharge is fixed by the time constants, RC , of these condensers. Moreover if C_3 and C_2 discharge themselves before C_1 does they will charge up again when C_1 discharges, due to this discharge sending another pulse of e.m.f. through the amplifier. It is then evident that the time constant RC should be only a small fraction of the time between two "dots" of a signal, for example, if the blocking is not to interfere with reading the signal. Hence RC must be made small and this must be accomplished by making C as small as permissible because if the leak resistance R is made small it would decrease the impedance of the grid-filament circuit so much that too large a proportion of the voltage $I_p R_1$ would be used up across the grid

¹ It must be pointed out that the amplifier as arranged in Fig. 19 will not amplify high-frequency spark signals; the condensers in series with the grids rectify the wave-trains so that in the later stages of the amplifier, only low-frequency signals occur.

condenser, thus cutting down the voltage impressed on the grid. The proper relative values of R and C to keep RC small must therefore be a compromise.

Suitable Value of Leak Resistance.—The leak resistance should be as high as possible without causing any of the tubes to “block.” The blocking would occur in case the grid became so negative as to make the plate current zero; the signal would, then, not go through until some of the electrons had escaped off the grid.

It is very difficult to lay down any exact rules or formulæ as to the best value of the leak resistance since some of the quantities which affect it, such as the number of electrons collected on the grid are somewhat indeterminate. It should be kept in mind, however, that a low leak resistance reduces the total impedance between points k and o on Fig. 19 and hence makes the drop over the repeating resistance very small, thus diminishing the amplification, and that a high leak resistance may cause the tube to “block.” In most amplifiers the leak resistance is in the neighborhood of 1 to 5 million ohms.

The resistances commonly used for “leaks” are made up of a thin strip of cardboard, clamped between two terminals, over which there is a coating of dried ink extending between the two terminals. The whole is enclosed in a glass tube. India ink is a poor conductor, and such a type of resistance as here described may be made up in units ranging from $\frac{1}{2}$ to 5 million ohms, depending upon the thickness and length of the ink line. Of course the power capacity of such resistances is extremely limited, and care should be taken not to overload them; they are meant to be used on low-voltage tubes only.

Another type of resistance used for “leaks” is the glass tube with the tungsten film deposited thereon already described on page 853.

As regards the connections of the low-frequency resistance-repeating amplifier to the rectifying devices for damped or undamped waves they are exactly similar to the connections for the low-frequency transformer-repeating amplifier shown in Figs 13, 14, 15.

In every case the rectifying device, be it for damped or undamped waves, is to be connected to the input points Q and S (Fig. 19) of the resistance-repeating amplifier.

Resistance-repeating Amplifier for High Frequency.—The connections of this type of amplifier for the purpose of receiving undamped waves are shown in Fig. 21, where the last tube is an autodyne rectifying tube. The input terminals of the amplifier are shown at QS and the output terminals at Q_1S_1 . The varying signal voltage existing across the terminals of the receiving condenser C is applied to the grid of the first tube and repeated from tube to tube, and it is finally made to affect the grid of the rectifying or autodyne tube after several stages of amplifica-

tion. It will be noted that the grid-filament of the autodyne tube is connected not only across the output terminals of the amplifier but also across

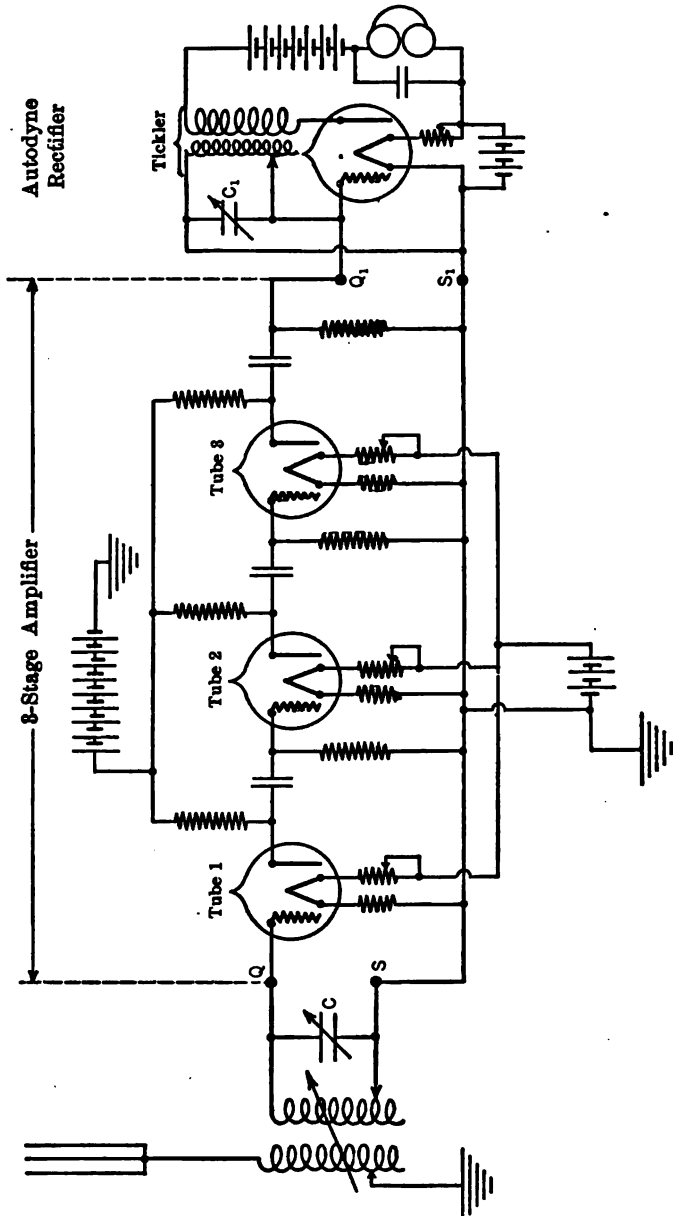

Fig. 21.—Resistance-repeating amplifier connected for reception of continuous wave signals.

the condenser C_1 of the local oscillating circuit; hence it will have impress upon it both the local oscillations and the incoming antenna oscillations

In the case of the incoming waves being damped the same arrangement may be used as shown in Fig. 21, after reducing the coupling between the grid and plate coils of the rectifying tube to the point where no oscillations are generated by it. The rectifying tube may, in the case of damped waves, be connected in the simpler manner shown by Fig. 22. The high frequency resistance-repeating amplifier is in no way different from the low-frequency amplifier of the same type and the two may be used interchangeably. The only point that must be noted in this respect is that the grid condenser may be made much smaller for the high-frequency than for the low-frequency amplifier, as already discussed on page 854, and, furthermore, it is very important that in the high-frequency amplifier the repeating-resistances be made with the least amount of distributed capacity, otherwise their impedance will be lowered and the amplification diminished.

As in the case of the transformer-repeating high-frequency amplifier the resistance-repeating amplifier suffers from the fact that at high radio frequencies the condensive reactance of the grid-filament circuit becomes so low as practically to short-circuit the repeating resistance, and consequently reduces the amplifying action. Thus a resistance-repeating amplifier which operates very successfully at audio-frequency may fail to amplify at all at radio frequency, not because of any fault of the amplifier, but because of the capacity of the grid to filament of each tube.

Inductance-repeating Amplifiers.—This type is similar to the resistance-repeating amplifier, except that instead of a resistance in the plate circuit of each amplifying tube an inductance is used whose reactance at the frequency for which the amplifier is designed, is high. The theory upon which the repeating action from tube to tube is based is exactly the same as for the resistance-repeating amplifier and will not be gone into here again. This method of repeating has an advantage over resistance repeating in so far as the repeating inductance offers but little opposition to the flow of the direct current through the plate circuit and hence the *B* battery may be of lower voltage than if resistance repeating is used. For this reason the inductance-repeating amplifier is to be preferred to the resistance repeater for low frequencies; but for high fre-

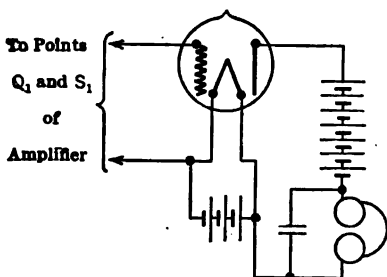

FIG. 22.—In case the resistance-repeating amplifier is used to amplify spark signals it will be found unnecessary to use a rectifying tube with condenser in series with grid for detector; the high-frequency signal will be changed to radio-frequency before going through the amplifier very far.

quencies the distributed capacity of the inductance introduces difficulties which make it less desirable than the resistance repeater.

Suitable Value of Repeating Inductance.—Let X_1 = reactance of the repeating inductance at the given frequency. Then, using the same symbols and making the same assumptions as in the similar discussion on the repeating resistance given on page 851, we have:

$$\frac{E_{r_1}}{E_{r_2}} = \frac{\mu_0 X_1}{\sqrt{R_p^2 + X_1^2}} \dots \dots \dots (22)$$

The value of the ratio E_{r_1}/E_{r_2} increases continuously with increase of X_1 and has a maximum of μ_0 which will take place when $X_1 = \infty$. The relation between E_{r_1}/E_{r_2} and X_1 for a typical case is shown by the curve of Fig. 23, for which $\mu_0 = 6$ and $R_p = 10,000$ ohms. Comparing this curve with the similar one for the resistance repeater (Fig. 20), it will be noted that the value of E_{r_1}/E_{r_2} rises much more sharply for the inductance repeater than for the other, and, as a matter of fact, for the same value of repeating impedance the resistance amplifier gives a smaller ratio E_{r_1}/E_{r_2} than the inductance amplifier.

The curve shows that there is very little to be gained by using a repeating reactance larger than about 20,000 ohms, or twice the resistance of the plate to filament. On the basis of 20,000 ohms for the repeating reactance the inductance would need be about 3 henries for 1000 cycles per second and 0.006 henry for 600 meters.

Of course the repeating inductance for audio-frequency is built on an iron core in view of its very large value. The construction of this inductance is regulated by the same principles as the construction of the repeating transformers for audio-frequency amplifiers, i.e., low iron losses and small distributed capacity together with small dimensions.

In the case of the inductance for 600 meters, as given above, it will be noted that it is almost impossible to build an ironless inductance of 0.006 henry to fit in a comparatively small space and with little distributed capacity. The effect of the distributed capacity is to cause best repeating action to take place at a wave-length equal to the natural wave-length of the repeating coil; for other wave-lengths the repeating action will not be so good and may be very poor. A similar difficulty was noted in connection with the radio-frequency repeating-transformer amplifier, as discussed on page 848. A straight inductance-repeating amplifier is very poor for short wave-amplification. It may be improved, however, by connecting a variable condenser across the repeating inductance and adjusting it so that the condenser and inductance are tuned to the incoming frequency; the equivalent impedance of the combination will then be very high, while the value of the inductance may be made quite low and the condenser may be relied upon to tune up to the required frequency.

A similar tuned plate-circuit impedance has already been discussed for the case of transformer amplifiers.

Fields of Use of Radio-frequency and Audio-frequency Amplifiers.—For amplifying wire telephone or wire telegraph currents the audio-frequency amplifier is, of course, to be used. For receiving radio-tele-

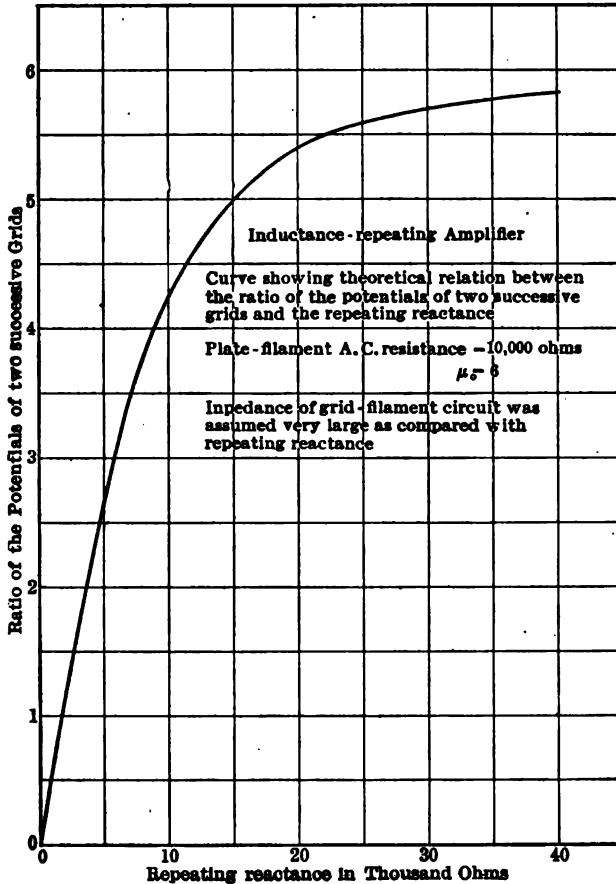

FIG. 23.—Amplifying characteristics of a tube using an inductance in the plate circuit; the amplification obtainable is much greater than with the same number of ohms of resistance.

graph or radio-telephone currents it is a question as to whether to amplify the received high-frequency currents first and then rectify them or to rectify them first and then amplify them. The former of these two methods requires the use of a radio-frequency amplifier and the latter of an audio-frequency amplifier. The advantage of using a radio-frequency amplifier lies in the fact that atmospheric disturbances and

other so-called "static interferences," which are always more or less seriously affecting the reception of signals, produce *audio-frequency currents*, which are amplified but little, or not at all by the radio-frequency amplifier; therefore, in this case, the final effect upon the telephone receivers, or any other device used for detecting the signals, is due more to the amplified radio-frequency signal currents than to the unamplified low-frequency interfering currents. On the other hand, in the case of the audio-frequency amplifier, this will amplify not only the rectified radio-frequency signal currents, but the atmospheric disturbances as well, so that the telephone receivers will be subjected to both the signal and the interfering currents which have been equally well amplified. It would seem, then, as if the radio-frequency amplifier would have the field entirely to itself, but, unfortunately, the radio-frequency amplifier is, as has already been pointed out, very difficult of construction for low, or even moderate, wave-lengths, on account of the effect of the grid-filament capacity of the tubes upon amplification. Tubes have been built where the grid-filament capacity has been reduced to a very low value and they have been employed with some success in the construction of high-frequency amplifiers, but they are still in the experimental stage. An amplifier quite extensively used during the war had three high-frequency air core transformer-repeating stages feeding into a detecting tube which in turn fed into a three-stage low-frequency amplifier. (The advantage of amplifying the high-frequency signal as much as possible before putting it into the detector tube will be realized at once when it is remembered that the detecting efficiency of a three-electrode tube increases with the *square* of the signal voltage.) The overall voltage amplification of this set was probably of the order of 10,000.

With the tubes at present available a good amplifier may be constructed for frequencies of the order of 50,000 cycles per second, and since this frequency is very much higher than that of most atmospheric disturbances, the latter will not be amplified, as much as the signal currents of 50,000 cycles will be. In an amplifier originated by E. H. Armstrong the difficulty of amplifying a high-frequency signal has been ingeniously overcome; in it the incoming high-frequency currents are first reduced by the heterodyne or autodyne method to about 50,000 cycles per second, then amplified through a number of stages and finally reduced again by another and last autodyne process to audio-frequency and transferred to the receivers. The arrangement is shown in a simple form in the schematic diagram of Fig. 24. It might seem that such an arrangement is very complicated to handle, but, as a matter of fact, it is no more so than the ordinary single tube autodyne set for receiving undamped waves. For it will be noted that the inductances and capacities in the second autodyne tube are fixed, and their values are originally adjusted so that, when

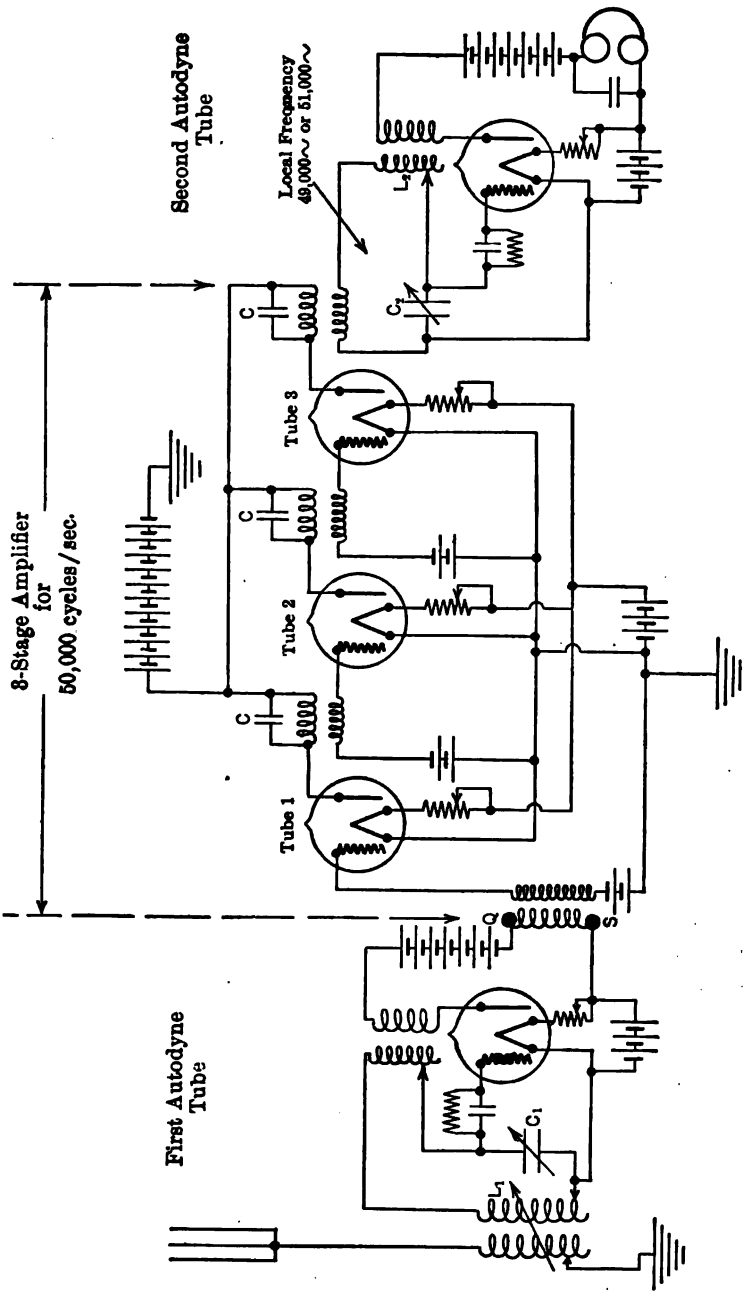

Fig. 24.—In this amplifier, due to Armstrong, the incoming high-frequency currents are first reduced (by beat reception and rectification) to about 50,000 cycles per second; this frequency is then amplified and at the output of the amplifier is made to act on an autodyne detector to produce audible signals.

electromotive forces of 50,000 cycles are induced in the circuit of L_2-C_2 by the amplifier, the telephone receivers will be subjected to a rectified current of 1000 cycles; in other words, the last autodyne tube is definitely adjusted to oscillate at a frequency of either 49,000 or 51,000 cycles per second. The only operation that the operator needs to perform, then, is to adjust the receiving inductance L_1 and receiving capacity C_1 so that the signal may be heard in the phones; when this is the case the frequency of the currents passing through the amplifier is either 50,000 or 48,000 cycles (assuming that the last autodyne tube is adjusted to oscillate at 49,000 cycles per second).

As already pointed out in the discussion of the transformer-repeating amplifier for radio-frequencies given on page 845, the plate circuits of the various amplifier tubes may be tuned to the frequency to be amplified, by means of condensers placed across the primaries of the repeating transformers. This may be very easily done in the case of the Armstrong amplifier without subtracting from the flexibility of the apparatus, since the condensers C, C, C shown in Fig. 24 need not be variable, but adjusted once for all to resonate, together with the primaries of the transformers, to 50,000 cycles.

Instead of a transformer-repeating amplifier one may use a resistance-repeating or else an inductance-repeating amplifier whose plate circuits have preferably been tuned to 50,000 cycles by means of fixed condensers connected across the repeating inductances.

If the amplifier be either a transformer-repeating or an inductance-repeating one the transformers or the inductances may, for this comparatively low radio frequency, be constructed with iron cores provided the laminations be made very thin (laminations of the thickness of 1.5 mils have been used) or still better, iron dust;¹ in this case the number of turns necessary to give the required reactance at 50,000 cycles for a tube of $R_p = 10,000$ ohms need be comparatively small and they can easily be constructed. If transformers or inductances with iron are used it is not necessary to tune the plate circuits by means of condensers, for the required reactance may be obtained without them. But if no iron is used the number of turns of the repeating transformers or inductances would have to be made so large as to require the use of shunting condensers around the coils to bring the impedance up to the required value.

The effect of the grid-filament capacity in a 50,000-cycle amplifier is, of course, not negligible, as in the audio-frequency amplifier, but it is not such as to affect seriously the amplifying action. Thus, assuming, as we did previously, the grid-filament capacity to be $50 \mu\mu f$, we have:

Reactance of grid-filament capacity at 50,000 cycles per sec. = 64,000 ohms, which reactance, while not as high as might be desired, is yet suf-

¹ See page 138.

ficiently high to prevent serious interference with the action of the repeating devices, provided the tube itself has a sufficiently low plate resistance, say $R_p = 10,000$ ohms.

Desirability of Different Characteristics for Various Stages of Amplification.—It has already been shown that the manner in which an amplifier operates is to cause an increase of voltage to be applied across the grid and the filament of any one tube over that for the preceding tube, so that finally the variations of the grid potential of the very last tube are many times larger than for the first tube. Thus, assuming a low-frequency transformer amplifier in which the ratio of grid voltages of two succeeding tubes is, say, 7 and, assuming, in addition, that the same ratio is maintained from the first to the last tube, then, we have:

Ratio of grid voltage of last tube of an n tube amplifier to grid voltage of first tube $= 7^{n-1}$.

We give below the values of 7^{n-1} for various values of n .

Number of tubes	7^{n-1}
3	49
5	2,400
7	118,000

It is apparent, therefore, that, as the number of tubes increases, the grid voltage applied to the end tubes increases enormously. It might seem, therefore, that different types of tubes should be used for succeeding stages, but such is not the case unless some loud-speaking apparatus is to be operated from the amplifier. In that case it is quite likely that the last tube of the amplifier will feed into a group of low-resistance tubes connected in parallel.

In one successful amplifier there were two tubes in cascade, each giving with its associated circuit a voltage amplification of 32, the two thus amplifying the impressed voltage about 1000 times. This amplified signal was supplied to the grids of three other tubes all connected in parallel. The μ_0 of these tubes was about 4 and their a.c. plate resistance 1500 ohms. Thus the three plate circuits in parallel had a resistance of only 500 ohms. In the common plate circuit was the primary of a step-up transformer having a ratio of 30 to 1, this voltage being supplied to a very high impedance load. The overall voltage amplification of this outfit was about 30,000.

For ordinary amplifiers of radio signals, however, it is not necessary to change the type of tube used in the various stages because, for the loudest signal an operator could stand the grid of the last tube of the amplifier need have an impressed e.m.f. of perhaps 1 volt; a comfortably loud signal is obtained with a fraction of this value. As practically any but the very highest impedance tubes operate very satisfactorily with

an impressed grid voltage even greater than this it is evident that it is entirely needless to change the type of tube.

Filters.¹—By the term “filter” is understood a network, or combination of resistances, inductances, and condensers (or merely two of these kinds of circuits) which “passes through” signals of one frequency better than it does others; in other words it is a selective conductor of some sort. If filters have resistances and inductances, or resistances and condensers, they are aperiodic, having no natural period of their own. If they contain inductances and condensers they may be periodic (i.e.,

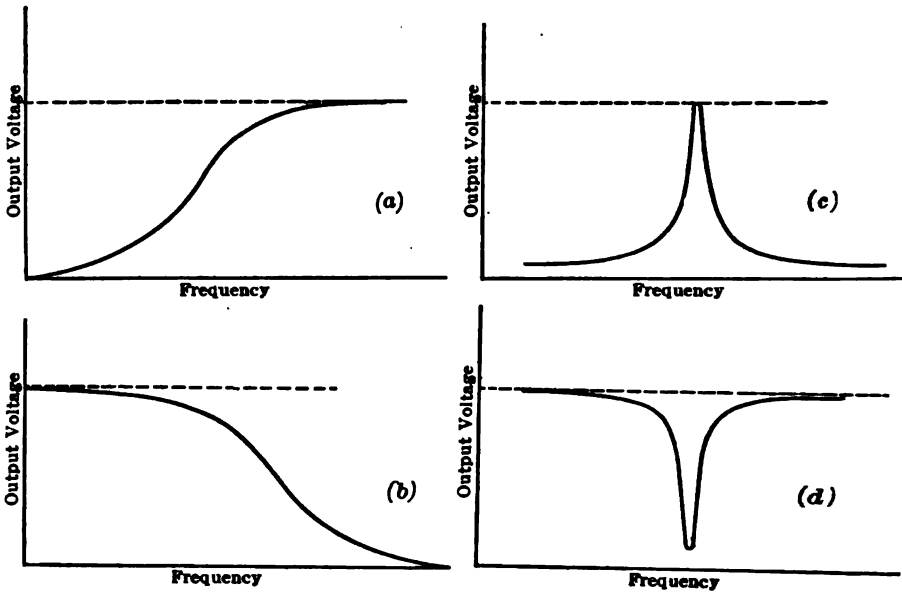

FIG. 25.—Characteristics of different types of filters *a* and *b* having either resistance and capacity or resistance and inductance while *c* and *d* must have resistance, inductance, and capacity properly combined.

having one or more natural periods of oscillation) depending upon how much resistance is associated with the network.

The characteristic of a filter is generally given by supposing a signal of fixed amplitude and variable frequency to be impressed on the input terminals and plotting against frequency, the voltage at the output terminals. For different types of filters we may get characteristics such as indicated in Fig. 25, (*a*), (*b*), (*c*), and (*d*). The first two (*a* and *b*) have only resistance and inductance or resistance and capacity used in

¹ For an excellent mathematical discussion of the properties of various types of filters the reader is referred to Chapter XVI of Pierce's "Electric Oscillations and Electric Waves."

their structure, while the other two have inductance, resistance and capacity.

A filter is generally applied to high-frequency amplifiers and may be constructed to serve either one or both of two different purposes, i.e.:

(1) To prevent signals from all transmitting stations, except one, from being amplified, and hence to keep interfering signals from reaching the operator's ear.

(2) To prevent currents due to "strays," "static," etc., from being amplified as much as they would otherwise be and hence to keep static interference from reaching the operator's ear.

These two purposes of the filter might be carried out as shown in Fig. 26. This figure represents a high-frequency resistance-repeating amplifier. It will be noted that all incoming currents which go past the tuned receiving circuit (*a*), will produce varying voltages across the grid-filament of the first tube and be thereby amplified into the plate circuit of this tube. Across the points *Y* and *O* there is connected the circuit $C_3-H_1-K_1-O$; the circuit from H_1 to K_1 consists of L_1-C_1 in multiple with the grid condenser C_4 , the leak resistance r_1 and the grid-filament of the second tube. For the sake of convenience this part of the amplifier circuit is reproduced in Fig. 27. The condenser C_3 serves the purpose of keeping the battery B_1 from sending any direct current into the circuit from H_1 to *O*, and may be made quite large, so as to have a low reactance at as low a frequency as 1000 cycles per second or less. The circuit L_1-C_1 is one that is tuned to the frequency which it is desired to amplify, and, of course, at this frequency it has a very high impedance, while at all other frequencies, higher or lower, it offers a lower impedance.

The characteristic of this filter is given by curve (*c*) of Fig. 25. The result is that the circuit of C_3, H_1, L_1-C_1, K_1 will practically short-circuit the resistance from *Y* to *O* at all frequencies except the one to which L_1 and C_1 are tuned, and, therefore, the repeating resistance R_1 will repeat but poorly all frequencies except the desired one. Of course the frequencies nearest the desired one will be repeated, though not strongly, into the second tube and these frequencies are still further weakened in the process of repeating from the second into the third tube, so that, finally, the output currents will contain the component of the original input currents of the desired frequency strongly amplified and components of other frequencies very much weakened or totally suppressed.

It will be noted that this type of filter acts as a barrier not only to high-frequency interfering currents, but also to low-frequency static interference. It has the objection of requiring the filtering circuits L_1-C_1, L_2-C_2 , etc., to be tuned to the incoming signal frequency, and, if this is a variable one, the tuning complicates the operation of receiving. The steady state impedance from H_1 to K_1 of the parallel circuit L_1-C_1 , is

about as shown in curve *c* of Fig. 28, where f_0 is the frequency of the signal which it is desired to amplify. The exact expression from which the curve can be plotted is given on the bottom of p. 71. It must be noted

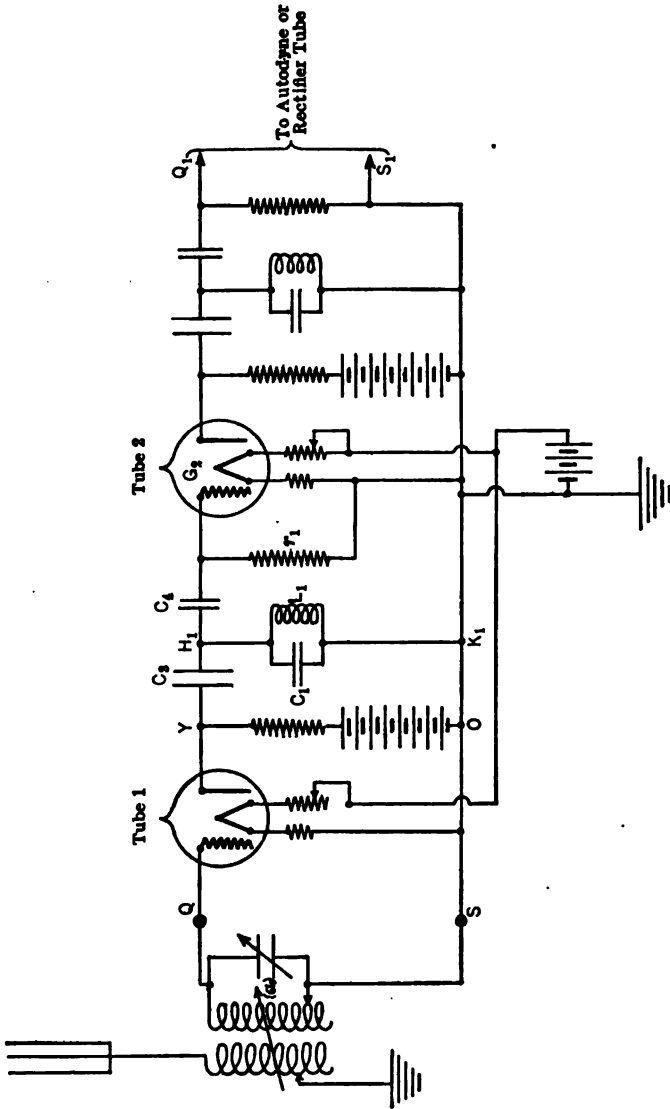

FIG. 26.—An amplifier using a short filter between successive tubes.

that this impedance curve holds only for the steady state, and hence gives no idea as to how the circuit will react to pulses or highly damped signals. In fact just because of the behavior of this circuit to pulses it is really a very poor filter to use with an amplifier for reasons now to be given.

It was shown on pages 268 et seq. that when a damped wave of e.m.f. is used for exciting a tuned circuit two distinct effects are produced. A forced current, of the same frequency as the impressed e.m.f., flows in the circuit, and another current of the same frequency as the natural frequency of the circuit is also set up. The relative amplitudes of these two currents are discussed in Chapter IV, page 270. It is therefore evident that any impulsive e.m.f. will start the circuit L_1-C_1 oscillating at its natural frequency which is practically the same frequency as that for which the amplifier is best adjusted; this pulse of e.m.f. (atmospheric disturbance) will therefore be sent through tube

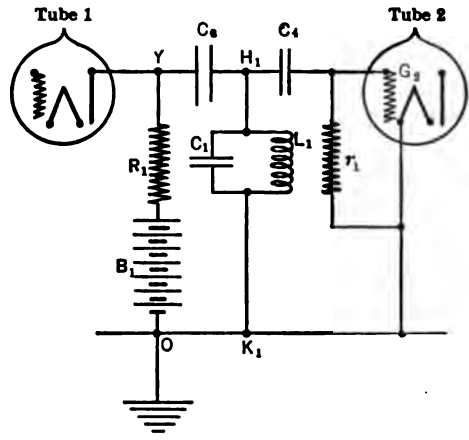
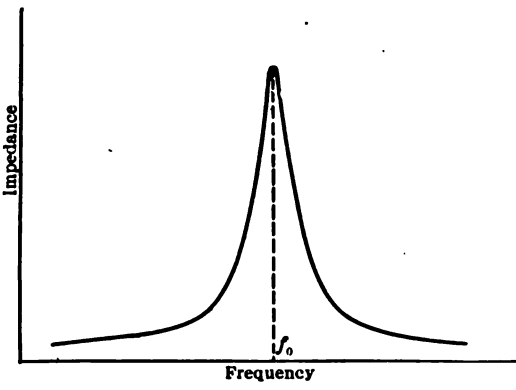

FIG. 27.—Circuit detail to show action of filter; the circuit between H_1 and K_1 practically short circuits any frequency except that for which it is tuned.

of the amplifier as a pulse but after passing the filter L_1-C_1 it will be propagated through the rest of the amplifier as a *damped wave-signal* of practically the same frequency as that for which the amplifier is adjusted,



g. 28.—The impedance between H_1 and K_1 varies with impressed frequency as shown here; the lower the resistance in the L_1-C_1 circuit the sharper is this resonance curve.

the damping of this spurious signal being fixed by the damping constant of circuit L_1-C_1 .

This is an effect which must be carefully guarded against in the design of amplifiers. With suitable filtering circuits the pulse A, Fig. 29, can be so affected that it comes through the amplifier with much less amplification than the signal B. But if tuned filter circuits are

ed it may be that the pulse will be changed to a damped signal and be applied to practically the same extent as the signal B.

This tuned type of filter is excellent for differentiating between two

continuous wave-signals of nearly the same frequency. For a continuous wave-signal (the "dot" of which lasts for several hundred cycles of the signaling frequency) curves like those of Fig. 25 give a correct idea of the relative selectivity of the filter, and, as the selection takes place progressively as it goes from one section of the filter (L_1-C_1) to the others (L_2-C_2 , etc.), the disturbing signal is completely nullified. If for example the desired signal is f_0 and the interfering signal is f' , it may be that

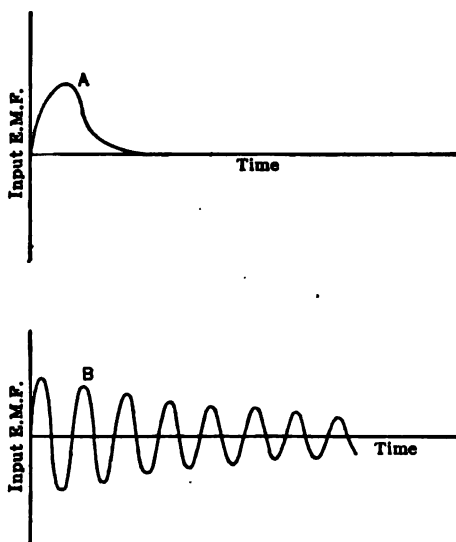

FIG. 29.—In a well-designed amplifier the pulse *A* will come through much less amplified than the signal *B* for which the amplifier is designed; when filters using inductance and capacity are used, however, tuned to the signal *B*, it is likely that the pulse *A* will be changed into a damped wave signal, of same frequency as *B*, and will be amplified as much.

one section of the filter will cut down the interference to .2 of its initial value and the desired signal to .98 of its impressed value. After going through three sections of such a filter the signal will be cut down to $.98^3$ or about .94 of its impressed value, whereas the interfering signal will be reduced to $.2^3 = .008$ of its impressed value. If the amplifying power of the tubes (apart from the filtering arrangement) is 100 times in voltage, the signal will come through the amplifier with a voltage amplitude 94 times as great as its input amplitude, whereas the interference would have but .8 of its input amplitude.

For differentiating between spark stations the relative selectivity is not as good, because of the natural oscillations

set up in the filter sections by the interfering signal; in fact for separating highly damped spark signals this filter is of practically no value.

Non-resonant Filters.—A simpler filter which acts to weed out low-frequency interference much more than it does high-frequency signals is the one shown in Fig. 30.

This diagram is similar to the one of Fig. 26 except that the resistance R'_1 is here substituted for the tuned circuit L_1-C_1 of Fig. 26. The general characteristic of this type of filter is shown in Fig. 25, curve (a). If a given amplitude of voltage of variable frequency, is impressed across the points *QS* (of Fig. 30) and the resultant voltage across *M-N* is

measured it will be found to have somewhat the form of the curve (a) of Fig. 26.

While no definite design of such a filter can be given here (it depend-

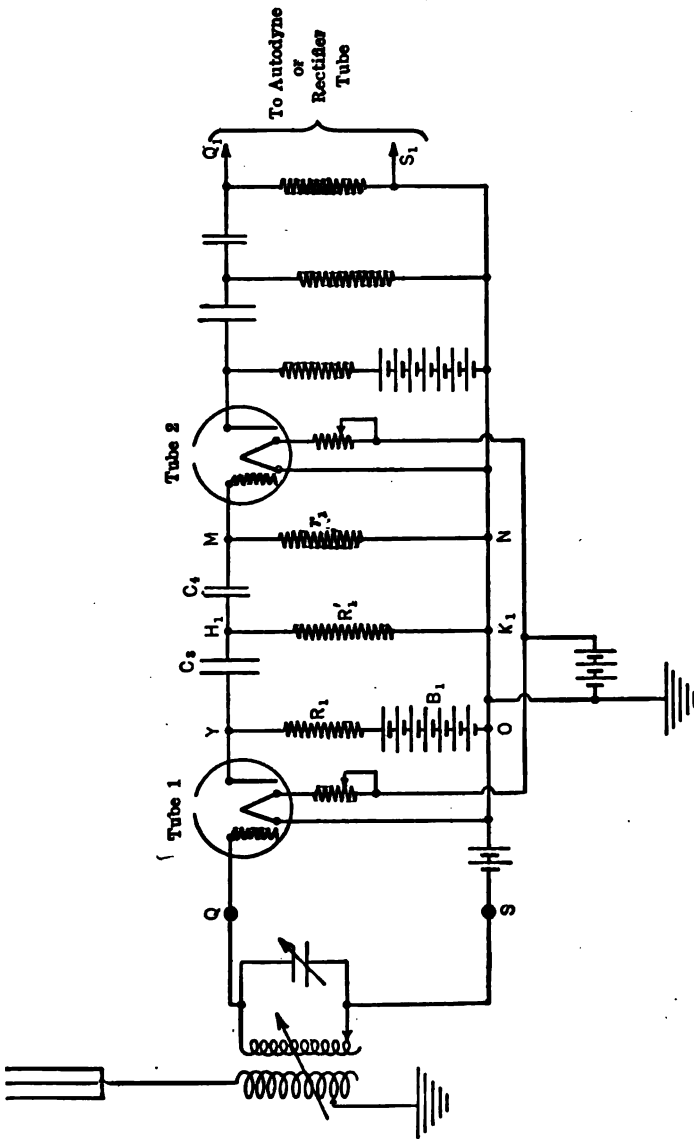

FIG. 30.—Aperiodic filters, such as the one used in this amplifier, while not as selective as those of the tuned type, are much more serviceable when much atmospheric disturbance is present.

g upon the tubes used, etc.) it has proved satisfactory to make the reactance of C_3 and C_4 for the signal frequency about one-fifth of the resistance R'_1 . In addition to this consideration the reactance of C_3 and C_4 in

series must be small compared to the impedance between points $M-N$, and, furthermore, the impedance of the network $C_3-R'_1-C_4-r_1$, etc., as measured between the points $Y-O$ must be high compared to the resistance R_1 ; and this resistance R_1 should be about equal to the resistance of the plate circuit of the tube. With this design of filter and amplifier circuit the voltage amplification per stage is about $\mu_0/3$.

As an example of how a filter of this kind differentiates between signals of different frequencies a case has been worked out in Fig. 31. Points $O-Y$ on the figure would normally connect across the plate circuit resistance of one tube, and points $M-N$

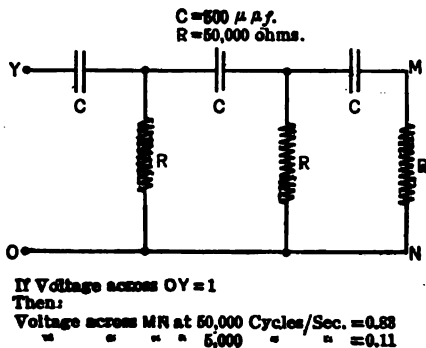

FIG. 31.—A section of a resistance capacity filter, through which 50,000 cycles is propagated with but little attenuation, whereas 5000 cycles is cut down to one-tenth of its incoming amplitude.

be small, at this frequency, compared to the inductive reactance of the coils (perhaps one-tenth as much). Iron core coils may be used, the dimensions of L_1 , L_2 , etc., being necessarily much larger than L_3 , L_4 , etc., because of the greater current they have to carry.

Stability of Amplifiers—"Squealing."—An amplifier, especially if of the inductance or transformer-repeating type, is very likely to produce in the telephone receivers audio-frequency sustained notes which are entirely independent of the incoming signals; this action is known as "squealing," and is extremely objectionable and very difficult to overcome. The squealing of an amplifier is generally due to the fact that the circuits of the various tubes are capable of oscillating, and may oscillate if the conditions are favorable; this applies to both high-frequency and low-frequency amplifiers. Thus assume, for the sake of clearness, that a single tube is connected by itself as it would be connected were it used in the low-frequency transformer-repeating amplifier of Fig. 13, page 842, and let Fig. 33 represent it. The coils of the repeating transformers T_1 and T_2 have a large amount of distributed capacity, and hence

would connect to the input circuit of the next tube of the amplifier.

Power from Generators for Amplifiers.—By using a suitable filter it is possible to use a small generator for lighting the filaments or for furnishing the plate current of an amplifier. Such an arrangement is indicated in Fig. 32. The amount of filter required will depend upon the quality of commutation of the machine. As the ordinary commutation frequency is about 1000 per second the reactance of each condenser used in shunting the line should

the circuit may be roughly represented by its equivalent of Fig. 34. It will be noted that L_1C_1 is an oscillating circuit and the grid is connected across it; furthermore the circuit L_2-C_2 may have a high impedance to currents of the natural frequency of the circuit L_1-C_1 . Any oscillations started in L_1-C_1 will produce a change in grid potential which will pro-

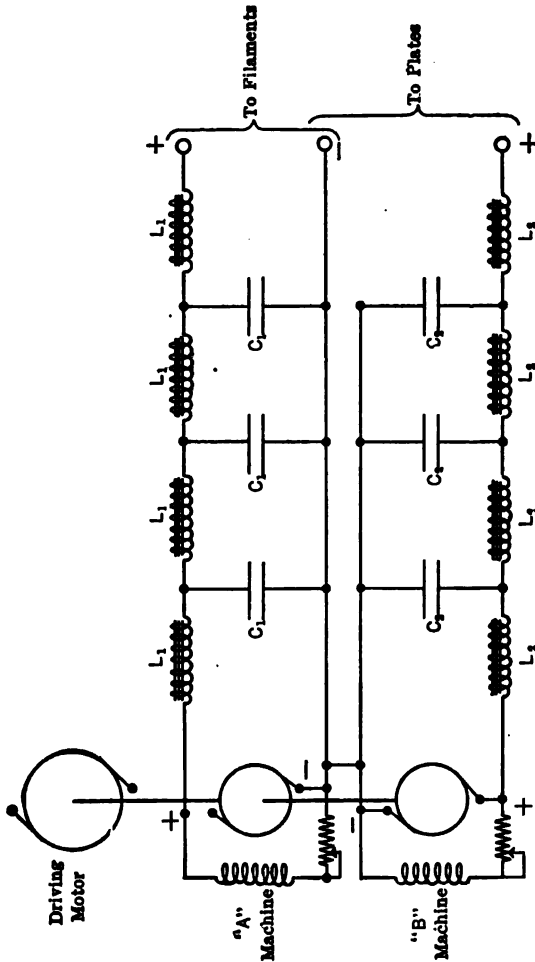

FIG. 32.—Generators may be used for the filament and plate circuits of amplifiers, provided suitable filters are used to cut out the ripples due to commutation.

duce a change in plate current; the latter will cause a variation of plate potential to take place, in view of the impedance of L_2-C_2 being connected in series with the plate battery, and finally the variation of plate potential may, through the capacity of plate to filament and grid to filament, react back upon the grid, and may impress a higher voltage across the circuit L_1-C_1 than at first existed. Such a condition would, of course,

be favorable to the maintenance of currents of the natural frequency of L_1-C_1 .

The tube may also oscillate at the natural frequency of L_2-C_2 ; whether it oscillates at the frequency of L_1-C_1 or of L_2-C_2 depends entirely upon which of these frequencies gives correct phases of e.m.f.'s and the smaller losses in the entire circuit.

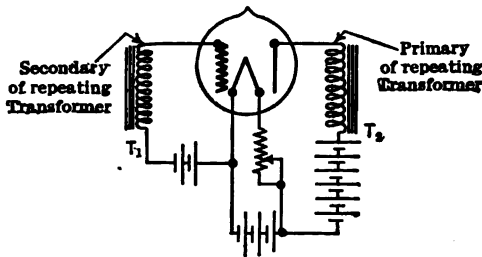

FIG. 33.—Circuit detail of a transformer repeating amplifier; it may well be that, due to internal capacities of the coils (giving the circuit a natural period) and the coupling between plate and grid circuit inside the tube, self-sustained oscillations are set up in the circuit.

If the frequency at which the tube oscillates is audible, the currents produced thereby will be heard in the telephones connected in the plate circuit of the last tube of the amplifier, and will thus produce squealing. If the frequency is inaudible the telephone will give no indication of the presence of such currents, but they will seriously interfere with the amplifying action of the tubes.

In the case of a high-frequency transformer-repeating amplifier the tube circuits may also oscillate, but they will do so at radio frequencies and will not be heard, but the efficiency of the amplifier as a whole may be seriously impaired by the presence of these interfering currents.

On the other hand inductance repeating high-frequency amplifiers, oscillating at radio frequency, sometimes produce an audible tone in the telephones due to the fact that the grid condensers may, as a result of the oscillations, become so highly negative as to cause the plate current to become zero and thus stop the oscillations; after a time the electrons collected on the grid will leak off and the plate current will start flowing; but the oscillations will again start in and again make the plate current zero, etc. This starting and stopping of the oscillations, with consequent pulsations in plate current, may take place at audio-frequency, in which case the amplifier will "squeal." This phenomenon is similar to the one fully discussed on page 523 in connection with oscillating receiving tubes equipped with grid condensers.

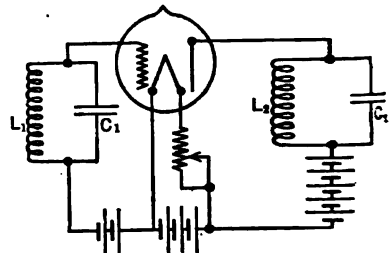

FIG. 34.—The transformer coils of Fig. 33, with their internal capacities give a circuit as shown here.

In the discussion given above we have, for the sake of simplicity

considered the action taking place in each individual tube, which may be caused to oscillate due to the varying currents in the plate circuit of that one tube reacting back upon the oscillating circuit to which the grid and filament of the same tube are connected. Of course each tube may be caused to oscillate in the same manner at the same or a slightly different frequency from every other. What does happen, however, is that all tubes are subjected to one single frequency and the value of this frequency is the one at which it is "easiest" for the entire amplifier to oscillate, that is, the one frequency at which the losses in the whole amplifier (for a given strength of oscillation) are a minimum; of course if these losses are greater than can be supplied by the plate battery through the reactions of each plate upon each grid circuit the amplifier will fail to oscillate at that frequency or at any other frequency for which this condition prevails.

It may happen, however, that the output circuit of the amplifier is coupled, either magnetically or electrostatically, or both, to the input circuit, in which case the amplifier may oscillate, even if it would not otherwise do so. Thus, consider the three-stage transformer-repeating amplifier of Fig. 6, which is similar to that of Fig. 13. Assume that oscillatory currents start in the secondary of transformer T ; these currents will be repeated and amplified from tube to tube; if now the plate circuit of the last tube is so related to the grid circuit of the first that the varying currents in the former can produce varying voltages in the latter, which are sufficiently large and in the right phase to increase and sustain the currents started in the secondary of transformer T , then the amplifier will oscillate. It will be easily understood that if there is coupling between the output and input circuit it is not a necessary condition, in order for the amplifier to oscillate, that the oscillations shall start in the grid circuit of the first tube, for, they may start in the grid circuit or even the plate circuit of any one of the tubes, including the last, and, in every case, the amplifying action of the apparatus may make it likely that oscillations be sustained, even if the coupling between the output and input circuits is feeble.

Again, while in the preceding paragraphs we have assumed that the plate circuit of the last tube is coupled to the grid circuit of the first tube the amplifier may oscillate even if the plate circuit of an intermediate tube is coupled to the grid circuit of the first tube or, in general, it may oscillate if the plate circuit of any one tube is coupled to the grid circuit of any of the preceding tubes. For, as long as any currents started in the oscillatory circuit of any one tube are sustained by the reactions of the other tubes the amplifier as a whole may oscillate.

Remedies for Amplifier Squealing.—It must be stated at the outset that the more an amplifier amplifies the more likely it is to squeal; in other words, a silent amplifier is not necessarily better than one which

shows tendency to self oscillation; in fact if a series of tubes connected in cascade show no tendency to squeal it is likely that the combination is so adjusted that the overall amplification is much lower than it should be. Even when all precautions against squealing have been taken it may be found upon testing the amplifier that it squeals most objectionably. In general the following points should be observed:

(a) An amplifier without any oscillatory circuits is not very apt to squeal. A resistance-repeating amplifier may be constructed practically without any oscillatory circuits, although it must be understood that even a short pair of wires from an oscillatory circuit, with a very high natural frequency to be sure, but nevertheless an oscillatory circuit. Hence even a resistance amplifier may oscillate at very high frequency and yet be "heard" if the grid condensers intermittently "block" the plate current. Resistance-repeating amplifiers (with an overall voltage amplification of about 25,000) have been constructed which do not squeal.

(b) Under no circumstances should the output and input circuits of an amplifier be coupled together even in the feeblest manner. It is best to use for both of these circuits short twisted leads and the output and input circuits should be kept as far apart as possible. The twisted leads should be "shielded" by enclosing them in a grounded flexible metallic casing. As a matter of fact it is advisable that all plate circuit leads be kept from being coupled to grid circuit leads of previous tubes; hence the leads inside of the amplifier box should be run with this very important point in view.

(c) Each tube and its holder should be placed in a shielded chamber, the surfaces of which are covered with copper connected to ground; this prevents any electrostatic or magnetic field from one tube from appreciably affecting the adjacent tubes or, in other words, it prevents coupling between adjacent tubes, since the energy contained in any varying fields produced by one tube is absorbed by the currents created in the surrounding copper. This precaution should always be taken in the case of high-frequency amplifiers especially.

(d) Wherever possible, separate plate batteries and filament batteries should be used for each tube, for in this manner a means of coupling between the tubes is done away with. Unfortunately, separate batteries for all tubes add so much to the weight, size, and cost of an amplifier as to make the arrangement impossible for any but special laboratory work. In any case both of these batteries should be of as low a resistance as feasible.

(e) All leads should be rigidly held in their proper places and all connections be well soldered.

Even when all these precautions have been taken it may be that an amplifier known to be correctly built, and of previous good behavior

gives loud "sputtering" noises in the telephones, even when the input circuit is short-circuited. This may be due to a "bad" tube somewhere in the amplifier (to be discussed in the next section) or it may be due to either the *A* or *B* batteries. A storage battery is practically always used for filament heating, so it is evident that this battery has a low resistance, but it will be found that if a good amplifier (high amplification) is used with an *A* battery nearly discharged (say lower than 1.8 volts for a lead cell) all sorts of odd noises may be heard in the amplifier, whereas if a normally charged *A* battery is substituted the amplifier is quiet.

The same remark holds true regarding the *B* battery to an even greater degree; the small dry cells generally used for the plate battery develop a very high variable resistance towards the end of their life, and if there is one such "worn-out" cell in the battery it will result in very bad noises in the amplifier. A test of the cells with a *low resistance* voltmeter will at once show of the defective cell.

Tube Noises.—Another feature which causes considerable difficulty in the operation of an amplifier is the "noise" produced by the tubes. The reader will realize that any slight change in the currents flowing in the plate or filament circuit of an amplifier tube, especially if it be one of the first tubes, may be so amplified as to finally produce a very large change in the plate current of the last tube, and hence a loud click in the phones. Sometimes these clicks are frequent and almost deafening as compared with the signals, hence very objectionable. As a matter of fact these noises form one of the limitations of amplifiers in so far as the number of stages is concerned, since it is almost impossible to prevent minute changes of currents in the first tubes, which, if repeated and amplified through a large number of stages, may finally "swamp" the legitimate signals. These minute changes of current in the tube circuits may take place due to several causes, the most common of which are:

- (1) Sudden slight changes in the electromotive forces of the various batteries (discussed in previous section).
- (2) Mechanical vibration of the elements of the tubes.
- (3) A slight amount of gas causing ionization, or, what is more difficult to overcome, actual irregularities in the rate of emission of electrons from the filaments. This is probably due to surface impurities of the hot filament.

It is evident that mechanical vibrations of the tube elements will vary the distance between the grid and filament and, of course, the plate current will change accordingly; the same is true of any changes in the distance between plate and filament and plate and grid. Hence the elements should be firmly supported. Of course, no matter how firmly

supported, they may always be made to vibrate, though imperceptibly, and yet enough to be detected by the amplifier; hence the care must be exercised in supporting the elements. The importance of this point was not at first fully realized, and tubes were used for aeroplane work the elements of which were not sufficiently well supported, with the result that an amplifier consisting of these tubes became practically useless. The matter of supporting the tubes themselves is extremely important in this connection and should be given the greatest attention. Amplifier tubes are generally supported on thick pieces of soft spongy rubber or else on light springs; the point to strive after is to obtain a support such that if the tube as a whole is caused to vibrate it will do so at a very low, inaudible, frequency, and, furthermore, it will not be able to communicate the vibrations to the elements of the tubes, the natural frequency of which is very high in view of the rigid suspension of the elements.

It will be realized that the behavior of the first tube of a multi-stage amplifier must be extremely regular if it is to produce inappreciable noises in the telephones at the output end. Assuming an amplifier which multiplies the input voltage by 10^4 having a resistance (or reactance) in the first plate circuit of 50,000 ohms and assuming that a voltage of .02 on the grid of the last tube will give an audible signal in the telephones, it may be seen that a change in current in the plate circuit of the first tube of only 10^{-10} ampere will produce an audible noise. This might be a variation in the plate current of the first tube of only one part in ten million! But if we try to conceive of the surface conditions of the hot metal from which the electrons are being boiled out, it seems impossible that the emission of electrons should be steady enough to eliminate such a slight irregularity. In fact it seems that with present tubes a much larger variation of the plate current is continually occurring.

Again any outside disturbances impressed on the input terminals even as small as 10^{-6} volt will produce an audible noise in the telephone.

We may therefore conclude that if the input circuit of an amplifier is not subject to interfering signals as great as 10^{-6} volt an amplifier may usefully be employed with a voltage amplification of between 10^4 and 10^5 , if quiet tubes are used in the first stages; with present tubes more than this (or as much as this in most cases) is not worth while; the signal may be made louder by using perhaps one or two more tubes, but in general it is no more readable.

Arrangement of Apparatus in Amplifiers.—In Fig. 35 is shown a three-stage audio-frequency amplifier using transformer repeating. The tubes used have $\mu_0 = 7$ and the transformer ratio is about 3.5; in series with the negative lead from each filament is a small piece of resistance wire, so that the grids are held at a negative potential, with respect to each filament. The filaments are in parallel the currents being controlled by

a common rheostat; the battery used in the plate circuit (the same battery serves all tubes) should be about 40 volts. An over-all voltage amplification of about 3000 is obtained, but there is generally an audible tube noise present, making it useless for reading very weak signals.

In Figs. 36 and 37 is shown a very carefully designed amplifier having its best performance for a signal of 6000 meters wave-length. Inductance repeating is used, the coils being toroids with iron-dust cores; they have a reactance of about 50,000 ohms. The tubes used have μ_0 equal to 35 and use a plate potential of 130 volts. The total voltage ampli-

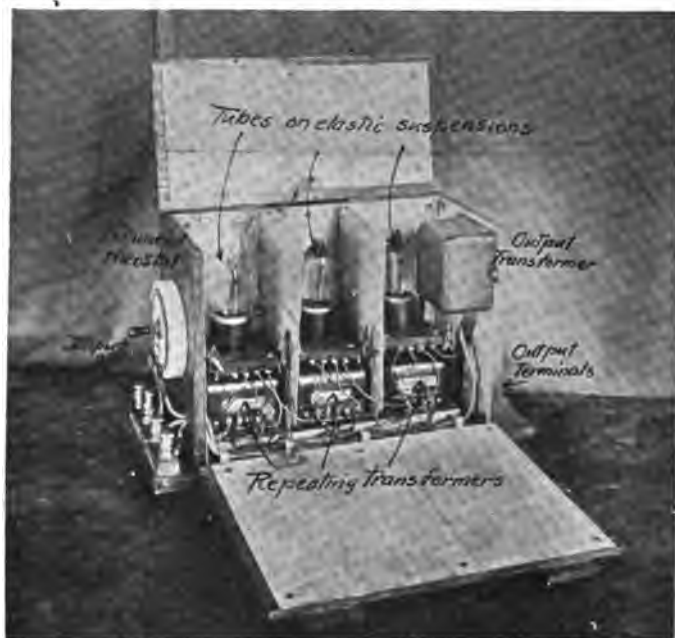

FIG. 35.—A compact transformer-repeating audio-frequency amplifier; the tubes are in spring suspensions, each in its separate metallic compartment. It has a voltage amplification of about 3000.

fication possible, without squealing, is about 50,000, but its useful amplification for very weak signals, is only about 5000.

This question of *useful* amplification is seldom mentioned in texts, but is really very important. It may be that two amplifiers are compared in the laboratory and it is found that one gives a voltage amplification ten times as much as the other. It may be that this comparative figure checks when different tests are made so that there is no doubt regarding its accuracy. It might be then assumed that if a signal giving a certain current in the antenna is just readable with amplifier A (the

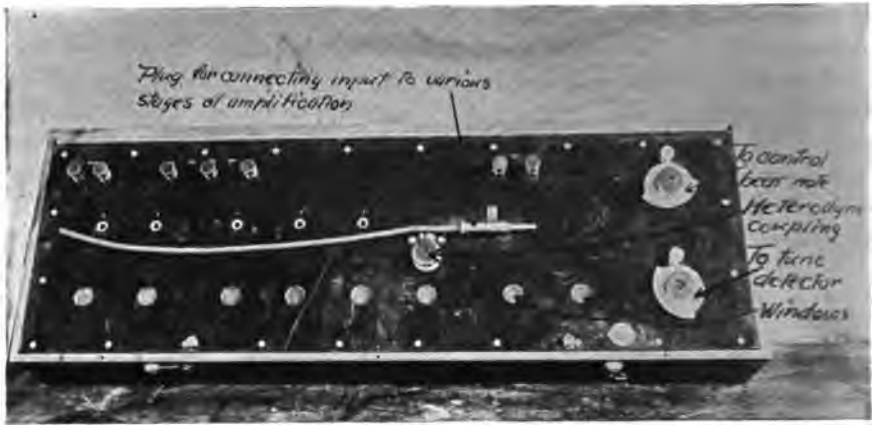

FIG. 36.—External appearance of a very well-designed amplifier for a frequency of 50,000 cycles; the input circuit can be connected to various stages by means of the plug and flexible cord. The total amplification of this instrument is about 50,000 but it can seldom be used efficiently with an amplification greater than about 5000 because of tube noises.

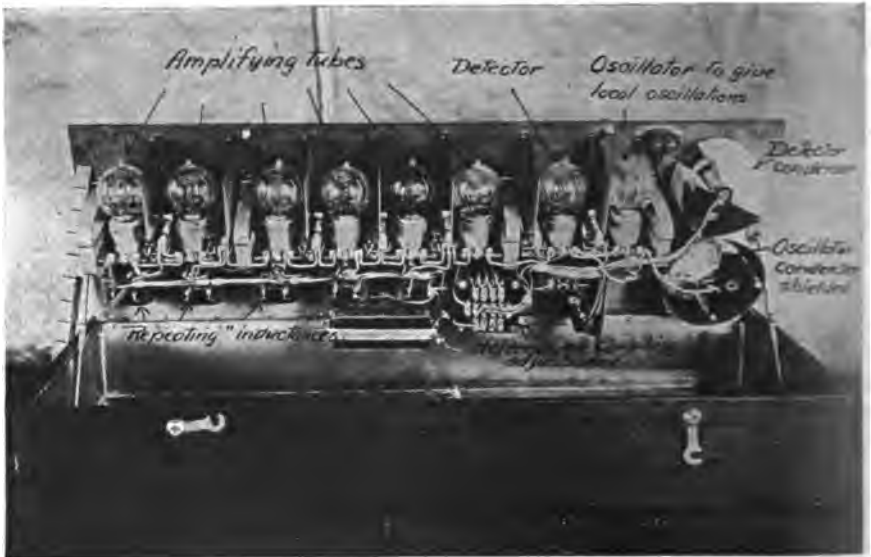

FIG. 37.—Arrangement of the apparatus of the amplifier shown in Fig. 36.

poorer one) that when amplifier *B* is used the signal would be readable if the antenna current were decreased to one-tenth its former value. It will probably be found, however, that when amplifier *B* is used an antenna current about one-half that used with amplifier *A* is the least audible signal, instead of one-tenth, as is naturally assumed. The reason for this is the "background" of noise (from tubes and other sources) present to a greater extent with *B* than with *A*. And the presence of the noisy background requires a much stronger signal in the phones when using amplifier *B* than is required when *A* is used.

CHAPTER XII

EXPERIMENTS WITH RADIO CIRCUITS

In this chapter is indicated a brief course of selected experiments to be performed in the radio laboratory. As in any branch of engineering, a laboratory course, to parallel the theoretical studies, is essential if the principles and actions of the apparatus investigated are to be fully understood and the greatest good obtained.

The experiments have been selected primarily to give the student training in the manipulation and operation of vacuum tubes in their several applications of detection, amplification, generation, and modulation; the first few experiments, however, are designed to investigate the action of coupled circuits, receiving circuits and spark transmitters. The apparatus requirements have been made as simple as possible consistent with satisfactory results, and most of the equipment specified should be found readily available in any laboratory intended for investigation of radio engineering problems.

EXPERIMENT NO. 1

Object

To investigate the phenomena of resonance in a simple series circuit and in two circuits coupled together by mutual inductance. To find the effect of coupling upon the form of the resonance curve and to study the effect of mistuning the secondary circuit.

Apparatus¹

Two fixed condensers C_1 and C_2 . (These should be of suitable value and may be equal in value, although not necessarily so.)

Two fixed inductances L_1 and L_2 . (These inductances should have such value that, when combined with C_1 and C_2 respectively, the oscillation frequencies are at the middle of the range of frequencies obtainable with the alternator available.)

¹ In this experiment, as well as those which follow, suitable values of apparatus constants have been suggested wherever considered desirable, and in the specific directions for each test, such suggested apparatus has been considered as available.

Alternator. (The speed should be widely variable so that a wide range of frequencies may be covered.)

One alternating current voltmeter.

Two alternating current ammeters (to measure primary and secondary current).

Frequency indicator. (Tachometer or speed counter will probably be found convenient as the voltage may be too low for the commercial frequency meter.)

One variable non-inductive resistance.

Operation

NOTE: In each test the terminal voltage of the alternator should be held constant throughout. A preliminary run should be made to insure all meters reading on scale at the resonant frequency and to prevent damage to meters and apparatus.

Test No. 1.—(a) Obtain the resonance curve for the circuit connected as shown in Fig. 1, using as low resistance in the circuit as possible.

(b) Repeat test 1 (a) with same alternator voltage, using a high resistance in the circuit.

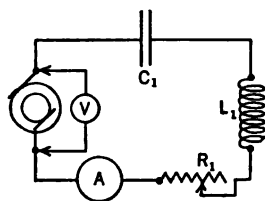

FIG. 1.

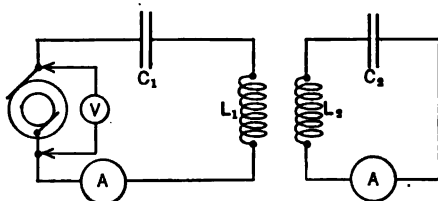

FIG. 2.

Readings of current and frequency should be taken, about ten or twelve readings at least being taken over the range of available frequencies. The readings may be spread out where the current changes but little with frequency and should be concentrated on the more rapidly curving portions of the resonance curve.

Test No. 2.—(a) Determine the resonance curves for coupled circuits connected as shown in Fig. 2, the primary and secondary circuits being tuned. A suitable alternator voltage will be about twice the value used in test 1. Use a coefficient of coupling K of approximately 0.05. If necessary, measure M , L_1 and L_2 , in order to determine K ($K = \frac{M}{\sqrt{L_1 L_2}}$).

Read the current in each circuit and frequency, as the frequency is varied, following the procedure indicated for Test No. 1.

(b) Repeat Test No. 2 (a), using a coefficient of coupling of approximately 0.15.

(c) Repeat Test No. 2 (a), using a coefficient of coupling of approximately 0.40.

Test No. 3.—Using a high value of coupling (say 0.40), determine the resonance curves for coupled circuits, with the secondary circuit mistuned about 50 per cent. (Increase or decrease C_2 so that $=\sqrt{L_2C_2} = 1.5\sqrt{L_1C_1}$ or $.5\sqrt{L_1C_1}$, choosing that variation which may be most convenient to make with the apparatus at hand.)

Curves

Plot resonance curves for each of the six runs specified above. Illustrative curves are shown in Chapter I, Figs. 53, 54 and 95. For tests Nos. 2 and 3, calculate ω' and ω'' , using formulæ (101), (102), (103) and (104), Chapter I. It is suggested that the student review that part of Chapter I dealing with coupled circuits before attempting to carry out the foregoing tests.

EXPERIMENT NO. 2

Object

Use of a buzzer-wave generator; setting up and adjusting a receiving circuit using a crystal detector; characteristic curves of a crystal rectifier by continuous current test; operation of a crystal rectifier on alternating current.

Apparatus

- Two dry cells.
- Fixed inductance L' (about 150 microhenries).
- Fixed capacity C' (about .005 microfarad).
- Buzzer rheostat.
- Buzzer.
- Variable inductance L (0–5000 microhenries).
- Variable capacity C (0–.0010 microfarad).
- Phones.
- Crystal rectifier.
- Micro-ammeter (0–1000 micro-amperes).
- Potentiometer.
- Low-reading d.c. voltmeter.
- Source of low potential alternating current. (May be conveniently obtained from an alternator operated with its field circuit open.)
- Low-reading a.c. voltmeter.

Operation

Test 1.—Connect the buzzer wave-generator in accordance with Fig. 3. Vary the buzzer adjustment and series resistance until a pure musical note is obtained.

Test 2.—Connect the receiver circuit in accordance with Fig. 4. Couple this circuit closely to the buzzer generator, and adjust the rectifying crystal until a loud signal is heard in the phones. Jar the crystal and note how easily its adjustment is spoiled. Note how easy or difficult it is to find another good rectifying point on the crystal. :

Test 3.—With tight coupling, and holding the inductance constant, vary the capacity until resonance is obtained (maximum signal in phones). Note the range of condenser adjustment over which the signal is heard. This is a measure of the *selectivity*. (See Note.) Repeat this test with various values of coupling, and note the relation between selectivity and coupling.

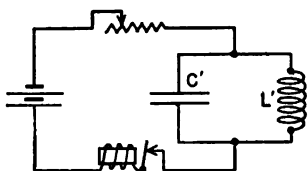

FIG. 3.

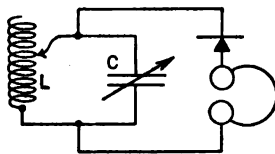

FIG. 4.

NOTE: A circuit is said to be *selective* when it is necessary (in order to get a maximum strength of signal) to adjust closely the value of inductance or capacity being used for tuning the circuit. If the signal is of about the same strength for widely different values of the tuning condenser or inductance, the circuit is said to be non-selective; or it may be said that the tuning is *broad* for such a circuit, while a *selective* circuit is said to have *sharp* tuning. A circuit which has no natural period is said to be "aperiodic."

Test 4.—With loose coupling make the inductance as low as possible, obtain resonance by varying the condenser, and note the strength of signals and selectivity. Repeat, using a very high inductance. Compare the strength of signals and selectivity in the two cases.

Test 5.—Obtain the continuous current characteristic of the rectifier (in this case a crystal), making the connections as indicated in Fig. 5. Vary the voltage impressed on the crystal from plus one volt to minus one volt. Get a reading of the current for each 0.1 volt between the limits named. The above test should be made for a point on the crystal which shows good rectification in the receiving circuit of Fig. 4. Obtain another curve for a second point on the crystal which shows poor detection

when tried with the buzzer. Make a note of which side of the detector is positive when the larger current flows.

Test 6.—Replace the battery shown in Fig. 5 by a low potential alternating current source and connect the a.c. voltmeter directly across this source.

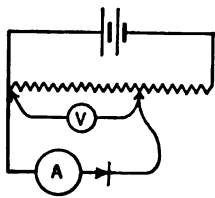

FIG. 5.

Starting with a potentiometer setting which gives the lowest voltage, get a series of readings of the micro-ammeter and of the impressed voltage, and note how the rectification varies with the impressed voltage. The voltage impressed across the crystal and galvanometer is to be calculated from the measured voltage of the a.c. generator and the position of the potentiometer contact; the resistance used in the potentiometer must, of course, be low compared to that of the crystal.

QUESTIONS

1. If in a buzzer circuit $L = 100$ microhenries and $C = .0004$ microfarad, what is the wave-length? If $C = .0002$ microfarad, what value must L have to generate a wave-length of 600 meters?

2. Judging from your experimental results is tight coupling or loose coupling generally desirable under actual field conditions where much interference is likely to occur?

3. A circuit is tuned for an incoming signal with certain values of L and C . If L is increased four times what change must be made in C to maintain the tuning?

4. What three characteristics should a good crystal rectifier possess?

EXPERIMENT NO. 3

Object

Study of the wave-meter; use of the meter for measuring the wave-length of low- and high-powered circuits, i.e., receiving and transmitting circuits; measurement of inductance and capacity by means of the wave-meter, using the meter as a detecting circuit or as a calibrated wave-generator.

Apparatus

Two dry cells.

Coil *A*—standard fixed inductance (about 50 microhenries).

Coil *B*—unknown fixed inductance (one designed for low voltage service).

Coil *C*—unknown fixed inductance (antenna loading coil or one coil of an oscillation transformer).

Condenser *D*—unknown fixed condenser. (Small capacity intended for low voltage service.)

Condenser *E*—unknown fixed condenser. (Condenser used for high voltage service, e.g., in the closed circuit of a spark transmitter, 2 or 3 Leyden jars in parallel would be suitable.)

Condenser *F*—unknown variable condenser (such as used in receiving circuit—is to be adjusted only for maximum capacity).

Wave-meter (range to at least 1000 meters).

Buzzer.

Buzzer rheostat.

Crystal rectifier.

Source of power for high power test (Test No. 7). This is most conveniently obtained by disconnecting the normal closed circuit capacity and inductance from an ordinary spark transmitter, no change being made in the low-tension circuit, step-up transformer or spark gap connections. (See Fig. 7.)

Operation

Test 1. Inspection of Wave-meter.—Open and inspect in detail whatever wave-meter may be available. Draw a diagram of the connections, and study carefully the various parts. Note how the *unilateral* connection of the detector and phones may be obtained.

Test 2. Measurement of Capacity.—Set up a buzzer-excited circuit as indicated in Fig. 6 and consisting of *A* and *D*. (See Note.) Measure by means of the wave-meter, the wavelength of the oscillations generated, using no tighter coupling than necessary (weak coupling is necessary if an accurate setting of the wave-meter is to be obtained). From the measured wavelength and the known value of the inductance calculate the capacity of the condenser.

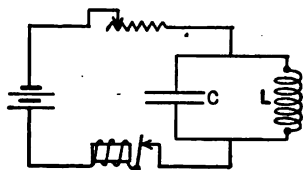

FIG. 6.

NOTE: In this and in subsequent tests make connections with short leads. Use particularly short leads in the oscillating circuits. The capacity of the leads connecting the condenser to the inductance or to the detector circuit or to the buzzer acts as part of the capacity of the oscillating circuit, thus making the capacity of the circuit greater than that of the condenser and giving an error proportional to the capacity of the leads. The error depends upon the value of the capacity of the condenser; for large condensers the effect is small, but for condensers of 100 micro-microfarads or less an error of 25 per cent may easily be made.

A similar error occurs due to the inductance of the leads in the oscillating circuit.

Test 3. Measurement of Capacity.—Repeat Test 2, substituting condenser *E* for condenser *D*.

Test 4. Measurement of Capacity; Computation of Capacity from Dimensions.—Repeat Test 2, substituting condenser *F* (set for maximum capacity) for condenser *D*. Before performing this test take apart condenser *F*, obtain the dimensions and number of plates, and compute capacity. Compare the computed with the measured capacity.

Test 5. Measurement of Inductance; Computation of Inductance from Dimensions.—Calculate the value of inductance of Coil *B* from its dimensions, and then measure it, using for a standard capacity such a combination of condensers *D*, *E*, and *F* as will produce a wave-length within the range of the wave-meter. This value of wave-length is to be calculated from the known values of the capacities and the computed value of the inductance.

Test 6. Wave-length of an Oscillating Circuit Excited by a Buzzer.—Measure the wave-length produced by the combination of Coil *C* and condenser *E*, using a buzzer circuit as in previous tests.

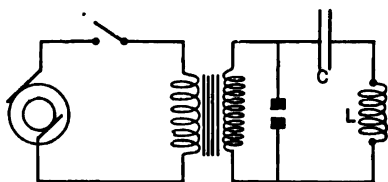

FIG. 7.

Test 7. Wave-length of an Oscillating Circuit Excited by a Power-set.—Transfer *C* and *E* to the high-power circuit shown in Fig. 7, and again measure the wave-length. It should be found that the wave-length for tests 6 and 7 is the same.

Test 8. The Wave-meter as a Wave-generator.—Connect the wave-meter as a wave-generator as indicated in Fig. 8 and couple to it the oscillating circuit consisting of coil *A* and condenser *D*, with detector and phones as shown in the figure. Vary the wave-length generated by the wave-meter until the test circuit indicates resonance; the wave-length of the test circuit is then read from the wave-meter. From this and the known inductance compute the capacity. It should be found that the capacity thus obtained agrees with that found in Test 2, when the wave-meter was used as the detecting circuit. What small difference occurs is due to the capacity and inductance of leads, personal error, etc.

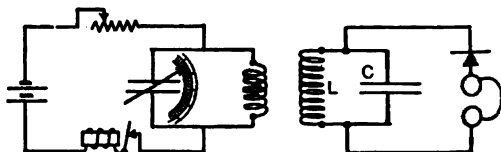

FIG. 8.

QUESTIONS

1. If the wave-length of a circuit is to be increased from 600 meters to 2500 meters how much must the L of the circuit be increased, the C of the circuit remaining the same?

2. The maximum capacity of the condenser of a certain wave-meter is 5500 micro-micro-farads. Its maximum wave-length is 6200 meters. What is the inductance of the coil used? If the range of the meter is to be increased to 12,000 meters how much inductance must be added to that of the meter?

3. A solenoidal coil has a winding 5 inches long, 25 turns to the inch, and is 4 inches in diameter. What is L in cm. and in microhenries and in millihenries?

4. A sliding plate condenser has eleven fixed plates and ten movable plates. The plates are 3 inches by $4\frac{1}{2}$ inches and the separation of adjacent plates is $\frac{1}{32}$ inch. What is the capacity in cm. and in microfarads?

EXPERIMENT NO. 4

Object

To set up and adjust a transmitting set, using inductive coupling; to investigate the effect on antenna current of tuning the antenna circuit to the closed circuit; effect of coupling on the amount of antenna current and wave-lengths radiated; energy distribution curve; determination of the decrement of the set; conductive coupling.

Apparatus

Source of alternating current supply (500~ or 60~) and step-up power transformer designed for radio service (about 1 kw. rating). Spark gap (plain open gap). Oscillation transformer (the inductances used may be of the flat spiral type, should be insulated for high voltages, and have a maximum inductance of about 40-50 microhenries).

High-voltage condensers for primary and secondary circuits. (These may conveniently consist of Leyden jars, properly connected. The amount of capacity will depend on the wave-length for which it is decided to adjust the set, but will probably not exceed .005 to .010 microfarad for either circuit.)

Hot-wire ammeter for antenna circuit.

Wave-meter.

Loading inductance (may or may not be needed, depending on relative values of closed and open circuit inductance and capacity).

Loading resistance (may be found necessary to limit current in antenna circuit to a safe value and will probably not be more than 5 or 10 ohms).

Switch for controlling the low-voltage supply to the step-up transformer (usually a S. P. S. T. switch).

Operation. Inductively Coupled Transmitter

Test 1. Connections.—Make connections as shown in Fig. 9 with the exception of the antenna circuit, which is to be left open; use short wires arranged in direct and orderly fashion. The high-voltage wiring between the power transformer and the primary winding of the oscillation transformer is dangerous, and must be so arranged that accidental contact with it is not likely. Before turning power on the set ask the instructor to look over the connections and to set the spark gap to a suitable length.

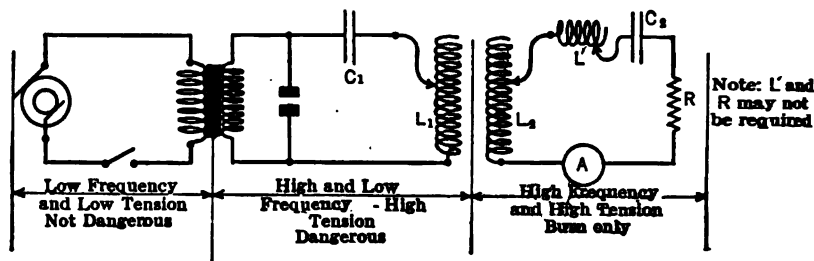

FIG. 9.

Test 2. Adjustment of Closed Circuit.—When the gap is sparking properly, place the wave-meter in proximity to the primary of the oscillation transformer and read the wave-length which is being generated. Change the amount of inductance used until the set is generating the wave-length for which the set is to be adjusted. Keep the antenna circuit open.

Test 3. Tuning of Antenna Circuit to Closed Circuit.—Close the antenna circuit or secondary oscillating circuit. In one of the connecting wires take two or three turns, making a loose coil about 3 inches in diameter. This coil is for exciting the wave-meter; it must be left fixed and treated as part of the inductance of the secondary circuit; although its inductance is small it will generally be large enough to effect the wave-length of the set and so must not be altered when investigating the effect of other changes in the circuit. It might seem that the wave-meter should be coupled to the secondary of the oscillation transformer to read the wave-length of this circuit, but this must not be done; the wave-meter indication when excited by the magnetic field of the oscillation transformer may lead to entirely incorrect conclusions. The coil used for exciting the wave-meter will be known as the "search-coil."

Tune the secondary to the primary circuit in the following manner with loose coupling: Vary the number of turns used in the secondary until the ammeter shows maximum current; at this point the secondary and primary circuits are tuned. Check this by adjusting the secondary turns so as to give maximum secondary current and reading the wave-length; it will be found to be the same as that to which the primary has been adjusted. Hence if the primary circuit of a set is calibrated it is not necessary to have a wave-meter to tune the secondary circuit; an ammeter in this circuit is all that is necessary.

Test 4. Relation of Antenna Current to Turns of Secondary of Oscillation Transformer.—To show more exactly the effect of tuning on the antenna current obtain a series of readings between antenna current and number of secondary turns, and plot a curve. Before getting this series of readings adjust the coupling of the oscillation transformer so that with *tuned circuits* the ammeter reads well up on its scale. This is to make certain that the maximum deflection will not exceed the range of the instrument.

Test 5. Energy Distribution Curves.—With the two circuits properly tuned, and tight coupling in the oscillation transformer, couple the wave-meter loosely to the search coil. Vary the setting of the wave-meter until a maximum reading of the wave-meter ammeter is obtained; increase the coupling of the meter to search coil until the wave-meter ammeter reads about one-half full scale value. Keep the adjustment of the wave-meter coupling constant while getting the three runs indicated in the next paragraph.

Take a series of readings of the wave-meter ammeter for various settings of the wave-meter condenser; get enough points to plot an accurate curve between wave-meter settings and ammeter readings. This curve shows the energy distribution of the oscillations in the secondary circuit. The wave-meter corresponds to a tuned receiving set and its indications show how strong a signal (relatively) variously tuned receiving stations would receive from this transmitting set. Get similar energy distribution curves for medium coupling and for loose coupling.

It will be found that for tight coupling two distinct waves are generated, neither of them being that for which the set is tuned. One of them is higher than the proper wave-length and one of them is lower. The amount by which the two waves differ depends upon the coupling, the difference diminishing as the coupling is weakened; for very weak coupling they merge together.

Test 6. Effect of Coupling upon Antenna Current and upon Energy Radiated at Tuned Wave-length.—Set the wave-meter to the tuned wave-length, vary the coupling between the primary and secondary of the oscillation transformer, and read the antenna ammeter and the wave-

meter ammeter for various values of coupling. It will generally be found that the antenna current continually rises as the coupling is increased, but the *amount of energy radiated at the true wave-length of the set* (indicated by the reading of the wave-meter ammeter, the wave-meter being a tuned receiving set) will be a maximum at some value of coupling considerably less than the maximum obtainable with the set. This is a very important point; a set should not be adjusted for maximum antenna current, but to *radiate a maximum power at that wave-length for which the set is tuned* (and hence that for which the listening stations are tuned.)

Test 7. Conductively Coupled Transmitter.—Carry out the tuning test for a *conductively coupled* oscillation transformer, using the primary of the transformer for the coupler, and making connections as in Fig. 10. Adjust the primary to the same wave-length for which the set was adjusted in Test 2, with the antenna circuit open. Close the antenna circuit and

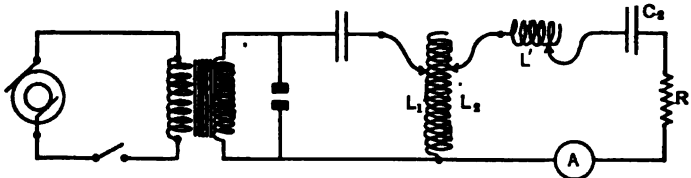

FIG. 10.

adjust the turns included in this circuit until the antenna ammeter gives a maximum indication. With this adjustment take an energy distribution curve by means of the wave-meter.

Test 8. Adjustment of the Spark Gap.—Carry out the following tests on spark gap adjustment with the antenna circuit open. Place a suitable hot-wire ammeter in the primary of the oscillation transformer. Set the gap to $\frac{1}{16}$ inch, and note current and character of sparking; repeat the gap settings of $\frac{1}{8}$, $\frac{3}{16}$, $\frac{1}{4}$, $\frac{5}{16}$, $\frac{3}{8}$ inch. It will be noted that if the gap is made too short for the voltage the set is generating the spark will change from a white snappy spark to a more or less transparent arc. This is especially true if the gap surfaces are rough and dirty.

The arcing type of spark makes a transmitting set practically inoperative because of the very small amount of high-frequency power generated with such a spark. If the gap of a set acts in this manner it should first be cleaned thoroughly and then the voltage of the set reduced or the length of the gap increased. It will be noted in support of this statement that when the gap has the arcing character the reading of the hot-wire ammeter, showing the amount of high-frequency current, is small compared to the reading when the spark has the snappy, noisy, and white appearance.

QUESTIONS

1. A spark gap is set to break down at 5000 volts; the closed circuit condenser has a capacity of .0009 microfarad; there are 350 sparks per second. How many watts of high-frequency power are generated in the closed circuit? If 60 per cent of this power is transferred to the antenna circuit and the effective resistance of the antenna is 8 ohms, what will the antenna ammeter read?

2. An open spark set is tuned for 410 meters; the coupling is 30 per cent. What wave-lengths are radiated? If the coupling is decreased to 8 per cent what two waves would be radiated? Would they appear as two waves with an ordinary receiving set?

3. Calculate the decrement of your transmitting set for one of the adjustments for which an energy distribution curve was obtained, using that curve showing the purest radiation. Assume the wave-meter decrement is .03, if it is not known.

4. From the energy distribution curve for the tightest coupling used in your experiment calculate the percent coupling for that adjustment?

EXPERIMENT NO. 5

Object

To measure the natural wave-length, inductance and capacity of an antenna and its variation with loading, etc. If time permits, to measure antenna resistance.

Apparatus

Large and small antenna, variable known inductance of about 4000 microhenries. Receiving coupler, phones, and detectors to set up aperiodic detecting circuit, wave-meter for wave-generator. Variable known condenser from about .001 microfarad to zero.

Operation

Test 1. To measure the natural wave-length of an antenna we use two other circuits coupled loosely to the antenna and so arranged that no energy can get directly from one into the other.

The wave-meter, used as a wave-generator, is coupled to the antenna, using only one or two small turns in the antenna for the coupling. The detecting circuit made up of one or two turns of the primary of a coupler in the antenna and all of the secondary coil, used with crystal detector and phone, forms the detecting circuit.

This detecting circuit responds equally well to all frequencies, being aperiodic. The antenna will absorb most energy from the wave-meter driver when the natural period of the antenna and that being generated by the wave-meter are the same.

The aperiodic circuit will, therefore, give a maximum of noise in the phones when the wave meter is impressing on the antenna a wave of its own natural frequency. This is then read directly from the wave-meter.

Carry out this test for both antennæ, using as small an amount of added inductance (for coupling) as is possible.

Test 2. To measure the capacity of the antenna, measure its wave-length (by method just described) when enough known inductance has been added in the base of the antenna and increase its wave-length at least four times. Knowing the value of this added inductance (and neglecting the inductance of the antenna itself) the capacity of the antenna is calculated.

Knowing the capacity of the antenna and also the natural wave-length (no added inductance) the inductance of the antenna may be calculated.

The capacity of the antenna may then be more accurately calculated by using the total inductance (the known inductance added in the base plus the antenna inductance). This corrected value will generally check the approximate value, obtained by neglecting the antenna inductance, within 1 or 2 per cent.

Test 3. The wave-length of the antenna is to be measured for various values of loading inductance and for various values of series condenser, exactly as was described above.

About ten points should be obtained for each curve, so selecting the values of inductance and condenser that the points obtained are uniformly distributed with respect to wave-length.

If time permits make the third run by putting a maximum loading in the antenna and shunt the condenser across the loading coil. Find the wave-length of the antenna for a very low value of capacity shunted around the inductance and take several more readings of antenna wave-length as the amount of shunted capacity is gradually increased.

Test 4.—The resistance of an antenna is obtained (for any given wave-length) by exciting from a sending set, having a hot-wire ammeter in the base of the antenna. Use no more power than is necessary to give a good deflection on the lowest range hot-wire meter available. Now add in series with the antenna (at its base) a non-inductive resistance of sufficient value to cut down the current in the antenna to 50 per cent its former value, leaving the exciting circuit exactly the same.

Neglecting a certain small correction, the value of which depends upon the ratio of the decrements of the antenna circuit and driving circuit, the value of the added resistance is just equal to the antenna resistance.

In case a quenched gap is used in the exciting circuit, the value of resistance obtained should be increased by about 20 per cent.

Another method for getting the resistance is by getting the decrement of the antenna at various wave-lengths, using quenched spark excitation. The resistance is then obtained by the relation

$$\delta = \pi R \sqrt{C/L}$$

If C and L are not known the decrement may be obtained after a small non-inductive resistance has been added in the base of the antenna. This combined with the decrement obtained before the addition of resistance, will give the antenna resistance even if L and C are not known.

The tests outlined above are for damped wave excitation; the results of the test should be checked by measurements with continuous wave excitation after Ex. 11 has been carried out.

QUESTIONS

1. Why is it necessary to use few turns in the coupling coils, when measuring natural wave-length? How could you tell (approximately) the natural wave-length of a ship's antenna? About how much is the capacity of a ship's antenna?

2. How many microhenries of inductance would you add in the base of such an antenna to increase the wave-length to 1000 meters? to 2500 meters?

3. Using the same width spreader, how much might the capacity of a 4-wire aerial be increased by increasing the number of wires to eight? Explain.

4. Would the capacity of a ship's aerial change as coal is taken on board? Why? How much? How much would such a change, alter the natural length of the aerial?

5. Why are aerials always operated at a wave-length greater than the natural wave-length?

6. Of what two general components is the total resistance of antenna composed?

7. How do these vary with the wave-length radiated from the antenna?

8. Explain the difference between the shape of resistance curves of a land station and a ship station?

9. If a land station shows a high ground resistance, how would you attempt to remedy it? Why is a high ground resistance objectionable?

10. Show by sketches the distribution of current and voltage in an antenna for the three cases, first, antenna, by itself; second, antenna with loading coil in base; third, antenna with series condenser in base.

11. Explain how the series condenser cuts down the natural wavelength of an antenna.

12. What is the effect on the antenna resistance of adding loading coil in base of antenna and also of adding series condenser?

13. How will the decrement of an antenna vary as the amount of loading inductance is increased?

14. What is likely to happen to a series condenser in the base of an antenna? Why? How may it be prevented?

15. In what part of a ship's antenna is the current a maximum?

EXPERIMENT NO. 6

Object

To determine the continuous current characteristics of a three-electrode tube, using a tube suitable for receiving and amplifying radio signals. Free grid potential. Effect of low plate voltage or low filament current on the characteristics of the tube. Effect of reversed plate battery or reversed filament battery.

Apparatus

One vacuum tube (receiving type, as for instance, the Western Electric Co.'s VT-1, or General Electric Co.'s VT-11).

Vacuum tube receptacle.

Two dry cells (to be used for grid potential).

Ammeter (for filament current).

Milliammeter (for plate current).

Micro-ammeter (for grid current).

Potentiometer (should be of high resistance).

Voltmeter (for reading plate voltage).

Low range voltmeter. (For reading grid voltage. If voltmeter for measuring plate voltage is equipped with low-range scale, this instrument will not be required.)

Rheostat for filament circuit.

Dry battery for plate circuit (about 40 volts).

Storage battery (for filament circuit).

Operation

Test 1. Tube Characteristic under Normal Conditions of Plate Voltage and Filament Current.—Grid voltage vs. plate current and Grid voltage vs. Grid current curves should be plotted for each of the tests indicated, plotting current on the Y axis.

Connect the tube in accordance with Fig. 11 with the negative side of the filament as the common junction. With plate voltage about 20 volts, filament current = 1.1 ampere, vary grid potential from +2 to -2 volts in steps of 0.2 volt, and read plate current and grid current for each adjustment of grid voltage.

Test 2. Free Grid Potential under Normal Conditions of Plate Current.—

Determine the free grid potential by reading the plate current with grid entirely disconnected from the rest of the circuit. From this reading of the plate current and the tube characteristic curve obtained in Test 1, the free grid potential may be obtained.

Test 3. Tube Characteristic with Reduced Plate Voltage.—Repeat Tests 1 and 2, using about half plate voltage, filament current = 1.1 ampere.

Test 4. Tube Characteristic with Reduced Filament Current.—Repeat Tests 1 and 2, using normal plate voltage, filament current = 0.8 ampere.

Test 5. Tube Characteristic under Normal Conditions of Plate Voltage and Filament Current with Plate Battery Reversed.—Repeat Tests 1 and 2 with plate battery reversed.

Test 6. Tube Characteristic under Normal Conditions of Plate Voltage and Filament Current with Filament Battery Reversed.—Repeat Tests 1 and 2 with filament battery reversed, the positive side of filament now being the common junction.

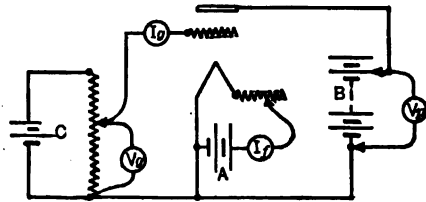

FIG. 11.

QUESTIONS

1. What is the normal resistance of the plate circuit of the type of tube used in this experiment?
2. What is meant by the space charge in a vacuum tube and what is the effect of the grid potential upon its action?
3. What effect does a low plate voltage have upon the characteristic curves of a tube? What effect does a low filament current have?
4. What is the effect upon the characteristic curves of a tube of using as the common junction the positive side of the filament instead of the negative?

EXPERIMENT NO. 7

Object

Study of the connections and use of the three-electrode vacuum tube as a detector of high-frequency damped waves with and without suitable grid condenser. Effect of the grid condenser leak. Effect of using too

large or too small a grid condenser. Effect of filament current and plate voltage upon the detector action of the tube. Effect of reversed plate battery or reversed filament battery. Comparison of the vacuum tube and rectifying crystal as detectors.

Apparatus

Vacuum tube (similar to that used in Experiment No. 6).

Vacuum tube receptacle.

Storage battery for filament circuit.

Dry battery for plate circuit (about 40 volts).

Two dry cells for buzzer circuit.

Ammeter for filament circuit.

Voltmeter for measuring plate voltage.

Phones.

Buzzer and rheostat.

Two fixed inductances (about 50 and 150 microhenries).

One fixed condenser for buzzer circuit (about .002 microfarad).

One fixed condenser for shunting phones (about .005 microfarad).

Three fixed condensers for grid circuit (about .005, .0001 and 1 microfarad).

Three leak resistances for grid circuit (about 2 megohms, 50,000 ohms and 10,000 ohms).

One variable condenser (about .001 microfarad maximum capacity).

One crystal rectifier.

One filament circuit rheostat.

Two D. P. D. T. switches (one to be a reversing switch).

One S. P. S. T. switch.

Operation

Caution.—In making the tests indicated below, it is important that the receiving circuit be excited only by the *high-frequency oscillations* generated by the buzzer-wave generator. If the receiving circuit is placed near to the buzzer leads, which are carrying pulsating current of audible frequency, current of this frequency will be induced directly into the receiving circuit, and so heard in the phones. The signal thus received cannot be tuned out and may result in wrong conclusions. It is, therefore, important that the buzzer leads be short and kept remote from the receiving circuit.

If an audibility meter is available it may be used in connection with the phones, and its indications may be used instead of varying the coupling between receiving circuit and buzzer generator. The audibility meter must be of the constant impedance type.

Test 8. Detector Action of Tube with Different Grid Leak Resistances, All Other Conditions Normal.—Repeat Test 2 using grid leak resistances equal to 2 megohms, 50,000 ohms, 12,000 ohms, 0 ohm, and infinite resistance (open circuit).

Test 9. Detector Action of the Tube without a Grid Condenser under Different Conditions of Plate Voltage and Filament Current.—Try different values of plate voltage and filament current to see if good rectification may be obtained without the grid condenser. When best adjustment has been found note sensitiveness as compared with that of Test 2.

QUESTIONS

1. When no grid condenser is used, why is it difficult to find a good rectifying adjustment of the tube?
2. Why would the tube detect poorly when a grid condenser is used without a leak resistance, assuming no leak in the tube?
3. Why does a grid condenser with suitable leak make the rectifying action of the tube certain for a wide range of values of plate voltage and filament current?
4. A certain tube with grid condenser and leak rectifies well when the group frequency of the incoming waves is 120; it rectifies very poorly when the group frequency is 1000? Explain.

EXPERIMENT NO. 8

Object

To determine (a) the geometric amplifying factor (μ_0) of the tube and its variation with filament current and plate voltage; (b) the amplifying factor (μ), which represents the true amplification obtained when the output circuit of the tube is loaded, and its variation with external resistance in the plate circuit; (c) the internal plate circuit resistance (R_p) of a three-electrode vacuum tube and its variation with filament current and plate voltage.

Apparatus

Vacuum tube (similar to that suggested for experiment No. 6).

Vacuum tube receptacle.

Storage battery for filament.

Source of high-frequency current. (About 1000~. Source should be ungrounded. An oscillating tube generator may be conveniently used or a small alternator.)

Plate battery (40-volt dry battery).

Phones.

Variable resistance R (from 0 to 20,000 ohms). A plug box resistance is suitable.

Grid circuit battery (five or six dry cells in series).

Potentiometer (to consist of two plug resistance boxes connected in series— r_1 and r_2).

Hot-wire milliammeter (to be connected in series with potentiometer).

Operation ¹

Throughout the following tests (with exception of test No. 1 (d)) the grid voltage should be adjusted to a certain value and held constant at this value. This value may be arbitrarily chosen, although it is desirable to make E_c of that value which has been found to give the best performance with the tube, e.g., for reception or amplification.

Test 1.—Determination of μ_0 .

(a) With normal filament current and plate voltage, open switch S , close switch S' , and adjust r_1 , and r_2 until no sound is heard in the phones. Under these conditions:

$$\mu_0 i r_1 = i r_2$$

where i = the audio-frequency current through r_1 and r_2 , therefore,

$$\mu_0 = \frac{i r_2}{i r_1} = \frac{r_2}{r_1}$$

Since r_2 and r_1 are known, μ_0 is thus readily determined.

(b) Repeat the above determination holding the filament current constant at normal value and varying the plate voltage in fixed steps.

(c) Repeat the above determination, holding the plate voltage constant at normal value and varying the filament current in fixed steps.

(d) Repeat, holding plate voltage and filament current normal and varying E_c , the grid voltage through as wide range as convenient.

Plot the readings taken in runs b, c, and d.

¹ The student should refer to Chapter VI for detailed definitions of μ_0 , μ and r_p , and explanation of their variation and significance.

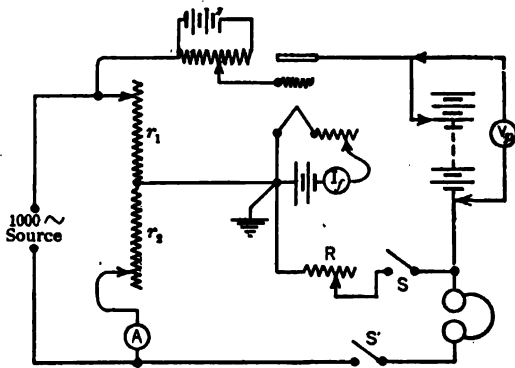

FIG. 13.

Test 2.—Determination of μ .

(a) With switch S closed and S' open and R set at the value at which μ is to be measured, vary r_2 or r_1 until when S' is closed no note is heard in the phones. Under this condition the alternating voltage drop across R is equal to the alternating voltage drop across r_2

or

$$i_p R = i r_2 = \mu i r_1,$$

and

$$\mu = \frac{r_2}{r_1}.$$

(b) Repeat test (a) with various values of R and plot results obtained.

NOTE: As R is increased E_b must be increased to keep E_p at its rated value (E_p represents the voltage impressed between plate and filament). To do this, note what plate current flows when R is made equal to 0 and E_b is at rated value for the tube. Then keep I_p at this value by increasing E_b as R is increased.

E_p must be kept small and should not exceed 0.1 volt. To make sure of this, the milliammeter A is connected in series with the potentiometer. From its indications and the known value of r_1 , the value of E_p ($=i r_1$) is readily obtained.

Test 3.—Determination of the internal resistance (R_p) of the tube.

(a) With normal values of filament current and plate voltage close switches S and S' . Adjust potentiometer resistance so that $r_1 = r_2$ and vary R until no note is heard in the phones. Under this condition

$$R_p = (\mu_0 - 1)R$$

where μ_0 is known from the results obtained in Test 1.

(b) Repeat test (a) using various values of plate voltage, holding the filament current constant at normal value.

(c) Repeat test (a) using various values of filament current, holding the plate voltage constant at normal value.

In case it is not feasible to get a balance with $r_1 = r_2$ then a suitable ratio of $r_1 - r_2$ may be chosen, in which case we have:

$$R_p = \left(\frac{r_1}{r_2} \mu_0 - 1 \right) R.$$

The results of tests b and c should be plotted.

EXPERIMENT NO. 9

Object

To measure the power output of an oscillating tube generator (with separate excitation) and its variation with plate voltage, filament current, excitation and plate circuit external resistance.

This test may be carried out at radio frequencies or at audio-frequencies (in fact 60-cycle excitation may be used). The values given for the supply voltage, resistances, etc., are made suitable for one of the smaller tubes mentioned below.

Apparatus

Vacuum tube. (For these tests a power tube should preferably be used. The Western Electric Company, VT-2 or General Electric Company, VT-12 or 14 would be suitable. Still better is a larger tube, such as the *G. E.* type *P* or type *U* plotron.)

Vacuum tube receptacle.

Dry battery for grid circuit (about 20 volts).

Source of alternating voltage for exciting grid circuit. (This may be conveniently obtained by means of another oscillating tube circuit.)

Ammeter for filament circuit.

Rheostat for filament circuit.

D.c. milliammeter for grid circuit (*E*).

D.c. milliammeter for plate circuit (*A*).

Hot-wire milliammeter for plate circuit (*A'*).

Plate battery or d.c. generator (since the normal plate voltage will be about 300 volts, the generator would probably be most convenient).

Shunting condenser for plate battery and ammeter (about 1 microfarad).

High value fixed inductance for plate circuit. This must be sufficiently large to give, at the frequency used, an impedance several times as large as the R_p of the tube used.

Condenser for load circuit (should have such capacity as will make its reactance small compared to the tube resistance at the frequency used).

Variable non-inductive resistance for load circuit. This should be adjustable in steps and should have a maximum value two or three times as large as the a.c. resistance of the plate circuit (output circuit) of the tube used.

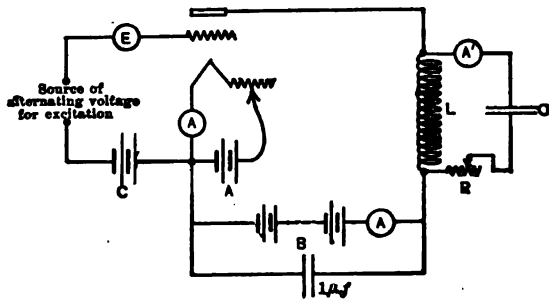

FIG. 14.

Operation

In all of the tests outlined below care must be exercised that the amount of power expended on the plate or grid is not greater than the safe rating for the tube used.

Part I.—The action of the tube will first be investigated with the plate circuit untuned since this is the easier circuit to manipulate. The large value of inductance should be inserted in the plate circuit during the following tests.

Test 1.—With suitable values of E_s , E_c ¹ and R , and with E_p normal, note the output of the tube and its variation as the filament current is varied, plotting your results in the form of a curve. A proper value for R makes it equal to the normal value of R_p .

Test 2. Repeat Test 1, varying the plate voltage instead of the filament current.

Test 3.—Repeat Test 1, varying E_p instead of the filament current. (In this test E_c must be varied so as to get maximum output at each setting of E_s , without, however, exceeding the safe rating of the tube.)

Test 4.—With all conditions normal, determine the variation in output of the tube, as the resistance (R) in the output circuit is varied.

In all of the foregoing tests the high-frequency power in the output circuit is given by

$$P = i^2 R$$

where i is the current measured by the ammeter A' . Due to the high impedance of L to high-frequency currents, it may be reasonably assumed that practically no high-frequency current passes through this branch.

Part II.—The characteristics of the generator when using a tuned-plate circuit will next be investigated. The high inductance should therefore be replaced by the low inductance to permit tuning the parallel circuit LC to radio frequencies. A suitable low inductance, such that the capacity used in parallel with it will permit tuning (parallel resonance) to the frequency used for grid excitation.

Test 1.—With all conditions normal, e.g., E_p , I_f , E_c of proper value, and E_s held fixed at a certain value, find the effect on the output of the tube of tuning or of not tuning the output circuit to the input frequency, using a low value of R .

¹ E_c should be held constant at some value which has previously been found to be most suitable for the tube when acting as a generator with all conditions normal. This will generally be about 80 per cent of the *maximum* value of the excitation voltage.

Test 2.—With the plate circuit tuned and all conditions normal, determine the variation in output with variation in R' , calculating for each value of R' the load circuit resistance as follows:

$$R'_{\text{load circuit}} = \frac{L}{C} \frac{1}{R} \quad (\text{see page 72}),$$

where L = inductance in henries;
 C = capacity in farads;
 R = actual resistance in the oscillating circuit.

Test 3.—With the load circuit adjusted for maximum output, find the effect of varying E_c , both above and below its normal value.

Plot curves showing the results obtained.

EXPERIMENT NO. 10

Object

Study of the power tube as applied to a typical oscillating circuit,¹ such as might be applicable to a radio telephone set. Effect of the plate inductance, the condenser in series with the antenna, the resistance in the oscillating circuit, the degree of coupling of the plate to the oscillating circuit, the plate voltage, the filament current, the grid condenser, the grid leak, and the grid potential.

Apparatus

Vacuum tube (similar to that used in Experiment No. 9).

Vacuum-tube receptacle.

Ammeter for filament circuit.

Rheostat for filament circuit.

Plate battery or d.c. generator (about 300 volts).

Ammeter for plate circuit.

Condenser for shunting plate battery and ammeter (about 1 microfarad).

Hot-wire ammeter for antenna circuit (may conveniently be a galvanometer and thermo-couple with a maximum range of about 0.5 ampere).

Wave-meter of suitable range.

Dummy antenna. (The constants of this antenna are arbitrarily chosen. A representative one would be:

$L = 40$ microhenries

$C = 400$ micro-microfarads (mica)

$R = 8$ ohms.)

¹The circuit which is investigated in this experiment is discussed on page 561 et seq. and the student should thoroughly review the theory and principles of operation as given there, before attempting to perform the tests specified.

Special low resistance inductance (L), variable in about 12 equal steps, for oscillating circuit (total inductance may be about 2000 microhenries).

Special condenser (C_1), variable in twelve equal steps, for oscillating circuit. (Maximum capacity may be approximately 3000 or 4000 micro-microfarads.) This condenser, the same as C above, should have negligible losses, preferably made with mica.

Variable plate circuit inductance (maximum value about 5000 or 10,000 microhenries).

Grid circuit battery (about 20 volts, with grid to be made negative).

Various grid condensers (from 100 micro-microfarads to 1 microfarad).

Various grid leak resistances (from 12,000 to 2,000,000 ohms).

Resistance for insertion into oscillating circuit (about 50 ohms).

All of above values are suitable for a VT-2 or VT-14 tube and the result obtained indicate the behavior of one of these tubes when used for signaling between aeroplanes and similar service.

Operation

Test 1. Adjustment of Plate Inductance.—Make connections as in Fig. 15, place the coupling contact M at D and the wave-length contact

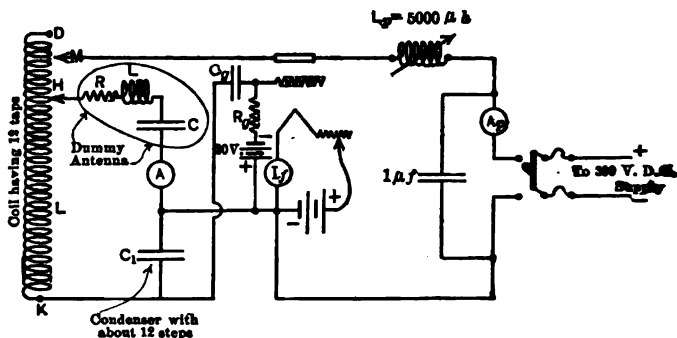

FIG. 15.

H at the third step away from D , use $C_g = 500 \mu\mu f$, $R_g = 12,000$ ohms, $C_1 = 1200 \mu\mu f$. Vary the plate inductance L_p , from its minimum to its maximum value and read A and A_p for each point on the inductance L_p . Note that the circuit can be made to oscillate for a limited range of values of L_p , and that when it starts to oscillate the plate current decreases. Note the value of L_p , giving maximum current in the oscillating circuit, and use it in the following tests.

Test 2. Effect of the Condenser in Series with the Antenna.—With all other adjustments as in Test 1 vary the capacity C_1 in series with the antenna from $50 \mu\mu f$ to $3200 \mu\mu f$ in the following steps: 50, 100, 200

400, 800, 1200, 1600, 2000, 2400, 2800, 3200, and read A , also measure the wave-length. Do not increase C_1 beyond the point where the circuit refuses to oscillate. Note that the circuit cannot be made to oscillate for certain values of C_1 , also that the value of C_1 affects the wave-length. Note the value of C_1 which gives the maximum current in the oscillating circuit and use it in the following tests.

Test 3. Effect of High Resistance in the Oscillating Circuit.—With all other adjustments as in Test 2 introduce a resistance of 50 ohms in the oscillating circuit and note A . Compare this reading of A with that obtained in Test 2 for best adjustment of C_1 .

Test 4. Effect of Shifting the Wave-length Contact H .—With all other adjustments as in Test 2 shift the wave-length contact H from point D towards K in steps, and note the step number, the reading of A , and also measure the wave-length. Note that, although this is primarily a wave-length adjustment, yet the coupling of the plate circuit to the oscillating circuit is also varied and hence the current in the oscillating circuit is varied.

Test 5. Effect of Shifting the Coupling Contact M .—With all other adjustments as in Test 2 shift the coupling contact M from D towards K in steps and note the step number, the reading of A and also the wave-length. Note that when the coupling contact is moved about half way down, the tube stops oscillating. The adjustment for this test is primarily a coupling adjustment, and should only affect the current in the oscillating circuit, the wave-length being but slightly affected.

Test 6. Effect of Plate Voltage.—With all other adjustments as in Test 2 vary the plate voltage from its normal value both up and down and note A . Be careful not to exceed the safe plate voltage and watts.

Test 7. Effect of Filament Current.—With all other adjustments as in Test 2 decrease the filament current in steps from its normal value to 1.0 ampere and note A . Note that A decreases with decreasing filament current.

Test 8. Effect of Value of Grid Condenser.—With all other adjustments as in Test 2 make the grid condenser C_g 100 $\mu\mu f$, 500 $\mu\mu f$, 5000 $\mu\mu f$, 1.0 μf , and note A and A_p . Note the best value of C_g .

Test 9. Effect of Value of Leak Resistance.—With all other adjustments as in Test 2 make the value of the leak resistance R_p infinite (open circuit), 2 megohms, 50,000 ohms, 10,000 ohms, and zero and read A and A_p . Note the best value of R_p .

Test 10. Effect of Holding the Grid at Different Negative Potential.—With all other adjustments as in Test 2 vary the e.m.f. in series with the leak resistance from zero to 30 volts in several steps and read A and A_p . Note that as this e.m.f. is increased the reading of A may decrease somewhat, but the reading of A_p decreases much more.

1. Why is it that in Test 1 too low an inductance in the plate circuit will prevent the tube from oscillating?
2. Why is it in Test 2 either too low or too high a value of C_1 will prevent the tube from oscillating?
3. From your results of Experiments 9 and 10 what is the effect of holding the grid at various negative potentials upon the output and efficiency of the tube?

EXPERIMENT NO. 11

Object

To measure the high-frequency resistance of a simple radio circuit and to determine the variation of this resistance with change in frequency.

Apparatus

Standard inductance whose inductance is practically independent of frequency (about 500 microhenries).

Standard variable condenser whose capacity is practically independent of frequency (about 0—.005 microfarad). (An oil-filled condenser is most desirable due to the large capacities obtainable and decreased losses.)

Hot-wire ammeter, of low range.

Known resistance R , which does not vary with frequency; radio cable of German silver strands is most suitable for this.

Source of undamped high-frequency current whose frequency may be varied from perhaps 50,000 to 300,000 cycles per second. (The oscillating tube circuit considered in Experiment No. 10, or its equivalent, may be conveniently used for this purpose.)

Wave-meter.

Operation

NOTE: When making the following tests, it is important to have sufficient power generated by the tube and transferred to the test circuit so that the currents will be reasonably large and easily read on the hot-wire ammeter. This will aid in minimizing the errors involved in the measurement, the accuracy of which depends largely on the precision with which the current is measured. It is also necessary to keep E , the e.m.f. induced in the test circuit, constant in value throughout the measurements.

¹ The student is referred to Bulletin No. 74, published by the Bureau of Standards, pages 180-187, for a complete treatment and discussion of these measurements.

Where tuned circuits are specified, particular care should be taken to insure the resonant condition being actually obtained; otherwise considerable error will be introduced into the results.

Test 1.—Determine the resistance of the circuit containing L , C , and the ammeter by means of the “resistance substitution” method, connections to be made as shown in Fig. 16.

Set the variable condenser C to some certain value and with the known resistance R omitted from the circuit vary the constants of the exciting tube circuit until resonance is obtained as indicated by a maximum reading on the hot-wire ammeter. Under this condition:

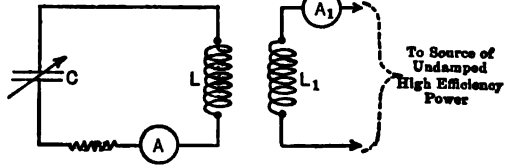

FIG. 16.

$$I = \frac{E}{R_x} \dots \dots \dots (1)$$

where E is the e.m.f. introduced into the circuit by induction in the coil L .

Then insert the known resistance R into the circuit as shown, and slightly re-tune the circuit, if necessary; again note the current, which now equals:

$$I_1 = \frac{E}{R_x + R} \dots \dots \dots (2)$$

(The reading of A_1 , and relative positions of L and L_1 must be the same as when making the previous measurement.)

Combining this expression with Eq. (1) we obtain the value of circuit resistance (R_x) as:

$$R_x = \frac{R}{\frac{I}{I_1} - 1}$$

Measure the wave-length of the set to get the frequency.

Test 2.—Determine the resistance of the circuit for the same frequency as in Test 1, using the “reactance substitution” method, using the same connections as above, without the extra resistance.

Carry out the first step specified in Test 1, setting the variable condenser to the same value of capacity and carefully adjusting the exciting source until tuned conditions are obtained. As before:

$$I_r = \frac{E}{R_x} \text{ or } I_r^2 = \frac{E^2}{R_x^2} \dots \dots \dots (1')$$

Then insert reactance in the circuit by changing the setting of the variable condenser until a considerable change in the current has taken

place. (Be sure that the current through the primary exciting coil is not changed during this adjustment; if it does vary, as indicated by a hot-wire ammeter in the tube circuit, the proper adjustment should be made to hold it constant.)

Under the new condition:

$$I_1^2 = \frac{E^2}{R_s^2 + X_1^2} \dots \dots \dots (3)$$

Combining (1') and (3) we obtain:

$$R_s = X_1 \sqrt{\frac{I_1^2}{I_r^2 - I_1^2}}$$

In this case:

$$X_1 = \pm \left(\frac{1}{2\pi f C_r} - \frac{1}{2\pi f C_1} \right) \text{ and } R_s = \pm \frac{(C_r - C_1)}{\omega C_r C_1} \sqrt{\frac{I_1^2}{I_r^2 - I_1^2}} \dots \dots (4)$$

L being known, *C_r* and *C₁* can both be readily determined by noting the resonant frequency of the circuit and then determining this frequency by wave-meter.

The resistance of the circuit (*R_s*) as obtained by this test should check the result of the previous measurement since all circuit apparatus and the frequency has remained the same.

Test 3.—Determine the resistance at eight or ten different frequencies from 50,000 up to 300,000 cycles per second, using either of the two methods just outlined.

Plot the results in the form of a curve, using frequencies as abscissa and the corresponding resistance as ordinates.

EXPERIMENT NO. 12

Object

Study of the oscillating tube receiving circuit; methods of detecting when a tube circuit is oscillating by indication of the plate current ammeter and by phone indication; effect of the degree of coupling, the oscillating circuit capacity, the oscillating circuit resistance, the plate voltage and filament current, upon the oscillations; periodic phone clicks produced in the oscillating tube circuit with grid condenser with improper adjustments; use of the oscillating tube circuit for the reception of continuous-wave signals; use of the regenerative action of the tickler coil for the amplification of damped-wave signals.

Apparatus

Vacuum tube (similar to that used in Experiment No. 6).

Vacuum-tube receptacle.

Storage battery, ammeter, and rheostat for filament circuit.

Dry battery for plate circuit (about 40 volts).

Galvanometer or sensitive milliammeter for plate current.

Voltmeter for plate voltage.

Phones.

Variable condenser (*C*) for oscillating circuit (one with a maximum capacity of about 1000 micro-microfarads would be suitable).

Coupler (an ordinary receiving coupler may be conveniently used, the primary or "tickler" coil having about 500 microhenries while the secondary may have about 4000 microhenries).

Resistance to introduce into oscillating circuit (about 50 ohms).

Shunting condenser for phones, plate, battery and ammeter (about .005 microfarad).

Grid condensers, similar to those specified in Experiment No. 7 (about .005, .0001 and 1 microfarad in capacity).

Grid leak resistances, similar to those specified in Experiment No. 7 (about 2 megohms, 50,000 and 10,000 ohms).

Source of continuous high-frequency oscillations (see Experiment No. 10 for tube circuit which may be used for this purpose).

Source of damped high-frequency oscillations (use buzzer wave generator).

Operation

Test 1.—Effect of the beginning of oscillations upon the plate current and upon the phones when no grid condenser is used.

Make connections as in Fig. 17. Make the plate voltage and filament current normal. Set for the weakest coupling possible between the tickler and the oscillating-circuit inductance.

This is done by using very few turns for the tickler coil and having the two coils of the coupler as far apart as possible. In case one of the coils of the coupler revolves, weakest coupling is had when the two coils are at right angles. Set the condenser in the oscillating circuit at 10 per cent of its maximum value; now increase the coupling by bringing the

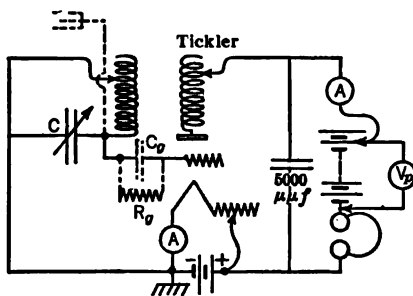

FIG. 17.

movable coil more and more within the field of the fixed coil, and note any change in the plate current and noise in the phones. When the coupling reaches a certain critical value, oscillations will start,

providing the two coils of the coupler have the proper relative polarities. The starting of the oscillations produces a sudden change in the plate current and a resultant noise in the phones; this noise has a peculiar quality, something like the plucking of a rubber band, and is sometimes difficult to detect.

In case no indication of oscillation occurs, even when the coils of the coupler are close together, increase the number of turns in the tickler coil. If the circuit still refuses to oscillate, it is almost certain that the relative polarity of the two coils of the coupler is incorrect, in which case reverse the connections to either coil and repeat the test, noting the phone click at the beginning of the oscillations, also the plate current before and after the oscillations have started.

Repeat the test with normal plate voltage and a filament current of about 75 per cent of normal, and again with normal filament current and a plate voltage of about 75 per cent normal.

Test 2.—Effect of the beginning of oscillations upon the plate current and upon the phones when a grid condenser and suitable leak resistance are used.

In the circuit of Fig. 17 introduce a grid condenser of 100 μmf and a grid leak resistance of 2 megohms and repeat Test 1 with normal plate voltage and filament current; also with normal plate voltage and reduced filament current, and with reduced plate voltage and normal filament current.

Test 3.—Oscillating condition as indicated by the "finger test" when no grid condenser is used.

With all adjustments as in Test 1 increase the coupling until oscillations start. After the oscillating condition has been reached the phones are quiet; they do not indicate the presence of the oscillations. The oscillating condition may, however, be tested for as follows: With the thumb on the common junction of filament and grid circuits touch the grid with one finger; this should give a click in the phones. Take the finger off from the grid, and the phones should give a click. Now reverse the connections to the tickler so that the circuit does not oscillate, and try the "finger test" as before; it will be noted that no click is heard in the phones either when the finger is placed on the grid or when removed from it.

Test 4.—Oscillating condition as indicated by the "finger test" when a grid condenser and leak are used.

Repeat Test 3 after introducing a grid condenser of 100 μmf and leak resistance of 2 megohms. Note that when the circuit is oscillating a click is heard in the phones both when the finger is placed on the grid and when removed therefrom.

On the other hand, when the circuit is not oscillating, although a

click is heard when the finger touches the grid, it will be found that there is little or no click when the finger is removed; this, however, may not always be the case, and the finger test in this case is not reliable.

Repeat the "finger test" both with and without grid condenser sufficiently to become convinced of the following summary of facts:

Condition of Circuit.	Finger Placed on Grid.	Finger Removed.
No grid condenser and no oscillations. . .	No click	No click
No grid condenser and with oscillations. . .	Click	Click
With grid condenser and no oscillations. . .	Click	Very likely to click
With grid condenser and oscillations. . . .	Click	Click

Check up the points listed in the above table which are borne out by experiment.

Test 5.—Effect of a high resistance in the oscillating circuit upon the coupling necessary to produce oscillations.

With all other conditions as in Test 1, find the position of the movable coil of the coupler necessary to start oscillations and note it. Introduce 50 ohms in the oscillating circuit and repeat the test.

Test 6.—Effect of the value of the capacity in the oscillating circuit upon the coupling necessary to produce oscillations.

With all other adjustments as in Test 1, note and record the position of the movable coil of the coupler necessary to start oscillations with oscillating circuit condenser set at 100 per cent, 60 per cent, and 10 per cent of its maximum value. Note that the smaller the capacity of the oscillating circuit the easier it is to start oscillations as indicated by the weaker coupling needed.

Test 7.—Effect of low plate voltage or low filament current upon the coupling necessary to produce oscillations.

With all other adjustments as in Test 1, note and record the position of the movable coil of the coupler necessary to start oscillations for the following conditions:

Plate voltage = normal value. Filament current = normal value.

Plate voltage = normal value. Filament current = 75% normal value.

Plate voltage = 75% normal value. Filament current = normal value.

Test 8. Periodic Phone Clicks when Grid Condenser is Used.—With normal plate voltage and filament current, grid condenser = 100 $\mu\mu f$, leak resistance = 2 megohms and tight coupling, start with the condenser in the oscillating circuit set at its maximum value, decrease it slowly, and note the reading of condenser when periodic clicks start. If the periodicity of the clicks is high enough, a musical note results and gives what is known as "squealing" or "singing" of the tube. Without changing

the leak resistance, determine the setting of the oscillating circuit condenser necessary to start periodic clicks with tight coupling for the following values of grid condenser: $1\mu f$, $5,000\ \mu\mu f$, $100\ \mu\mu f$. Also note the frequency of the clicks. Repeat the test with constant grid condenser of $100\ \mu\mu f$ and grid leak resistance of: infinity (open circuit), 2 megohms, 50,000 ohms, 10,000 ohms and zero.

Test 9. Reception of Undamped Wave-telegraphy by Means of the Oscillating Tube.—Set the circuit oscillating with conditions as in Test 1 and receive the undamped wave-signal sent out by an oscillating tube generator set up as in Experiment 10. (A small antenna should be connected to the point *H* on the transmitter and on the receiving circuit as shown to increase the energy received.) This is done by adjusting the oscillating circuit condenser until nearly in tune with the transmitter, when a "whistle" will be heard in the phones.

By interrupting the oscillations of the transmitter, signals may easily be transmitted.

Test 10. Regenerative Action of the Tickler Coil.—**Reception of Damped Waves.**—With all other adjustments as in Test 9, make the coupling much below that which will start oscillations, and tune by means of the condenser to receive the damped wave-signals sent out by the source of damped high-frequency oscillations. Note that the reception takes place when the tube is not oscillating. Gradually increase the coupling, continually retuning the receiving circuit for the incoming signal and note the great increase in the signal strength due to the regenerative action of the tickler coil as the coupling is increased. Too great a coupling results in oscillations and the musical quality of the signal is spoiled; it is therefore best to receive with the circuit just out of the oscillating condition, when the regenerative action of the tickler in amplifying the received signals will be a maximum.

NOTE: If poor signals are received due to the poor rectification of the tube, introduce normal grid condenser and grid leak.

QUESTIONS

1. From the results of Tests 1 and 2 what may the plate current do when oscillations start if no grid condenser is used, and if a grid condenser is used?
2. From the results of your tests what is the effect upon the strength of oscillations of: loose coupling, large resistance and large capacity in oscillating circuit, low plate voltage, and low filament current?
3. What is the reason for the singing of the tube when a grid condenser is used, and how may it be avoided?
4. An incoming undamped wave signal of a wave-length of 1000

meters is being received; the inductance in the receiving oscillating circuit is 400 microhenries; what must the capacity be in order to receive a beat note of 2000 beats per second?

EXPERIMENT NO. 13

Object

(a) Study of the low-frequency amplifier equipped with inductance "repeater." Investigation of the effect of the value of the inductance in the plate circuit upon amplifying power; effect of the value of grid condenser and grid leak resistance upon amplifying power: and effect of plate voltage and filament current.

(b) Study of the low-frequency amplifier equipped with transformer "repeater."

Apparatus

Two vacuum tubes (similar to the tube investigated in Experiment No. 6).

Two vacuum-tube receptacles.

Storage battery, ammeters and rheostat for filament circuit.

Dry battery for plate circuit (about 40 volts).

Voltmeter for measuring plate voltage.

Phones.

Buzzer wave generator. (This is exactly similar to the equipment described in Experiment No. 7, to be mounted on a small board to permit the whole circuit to be readily moved.)

Variable tuning condenser C (about .001 microfarad maximum value).

Fixed inductance L (about 150 microhenries).

Fixed inductance for Test 4. (Secondary of receiving coupler having about 4 millihenries inductance would be suitable.)

Grid condensers (Test 6). (.0001, .0005, .005 and 1.0 microfarad would be suitable. These condensers have already been used in previous experiments.)

Grid leak resistances (Test 7). (50,000 ohms and 2 megohms resistances may be used.)

D. P. D. T. switch.

Crystal detector (for use in Tests 9 and 10).

Shunting condenser for plate circuit (about .01 microfarad).

Grid condenser and leak resistance for receiving tube grid circuit (to be normal value for the tube: .0001 microfarad and 2 megohms would probably be satisfactory).

Grid condenser and leak resistance for amplifying tube grid circuit (.0005 microfarad and 1 megohm respectively).

Low air-core inductance (about 3000–5000 microhenries).

Iron core inductance for "repeating." (An inductance of 10 to 15 henries is required. This may be obtained in the form of an iron-cored and iron-shielded inductance wound with very fine wire, the whole being about 4 inches long and $1\frac{1}{4}$ inches in diameter. The d.c. resistance will be about 2000 ohms.)

Two iron-cored transformers for "repeating" (Tests 9 and 10). (Suitable transformers may be obtained which are contained in a case about $3\times 3\times 2$ inches. The inductance of the primary and secondary windings is about 3 and 30 henries respectively, and the turn ratio 3.2.

Operation

Test 1. Connection of a Tube Detector and Single-stage Low-frequency Amplifier with Inductance Repeater.—Make connections as per Fig. 18. Use for *G* a high-inductance coil of about 15 henries, for *K*

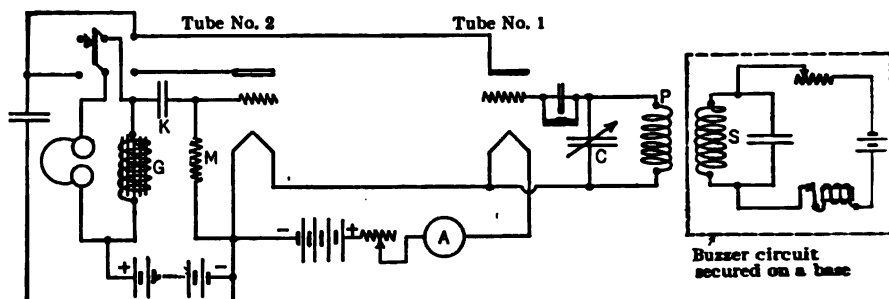

FIG. 18.

a 500- $\mu\mu\text{f}$ condenser, and for *M* a 1-megohm resistance. Note that tube No. 1 is being used as a detector of high-frequency damped waves, while tube No. 2 is being used as an amplifier of the low-frequency currents flowing in the plate circuit of tube No. 1. The double-throw switch permits the phones to be connected in the plate circuit of the first tube or of the second tube. Make the grid condenser of the first tube 100 $\mu\mu\text{f}$ and the grid leak 2 megohms.

Test 2. Measurement of the Sensitiveness of the First Tube as a Detector.—Connect the phones into the plate circuit of the first tube, make the filament current and plate voltage normal, and by means of the variable condenser tune to the buzzer signal. Move the entire buzzer circuit until the distance between the buzzer circuit inductance and the receiving circuit inductance (denoted by *P* and *S* in Fig. 18) is such that the phones give a "just audible" signal when the two circuits are in tune:

note and record the distance between the two inductances. This distance is, to a certain degree, a measure of the sensitiveness of the tube.

Test 3. Sensitiveness of the Two Tubes with Normal Repeating Inductance.—Place phones into the plate circuit of the second tube. Use for *G*, *K* and *M* (see Fig. 18) the values specified in Test 1. With all other conditions normal, measure the distance *P-S* necessary to make the signal just audible.

Test 4. Sensitiveness of the Two Tubes with Low Repeating Inductance.—Use for *G* the low air core inductance, and repeat Test 3 with all other conditions the same as in Test 3.

Test 5. Sensitiveness of the Two Tubes with Resistance Repeater.—Use for *G* a 50,000-ohm resistance and repeat Test 3 with all other conditions the same as in Test 3.

Test 6. Effect of the Grid Condenser of the Second Tube upon Amplification.—With all other conditions as in Test 3, measure the sensitiveness of the two tubes for values of the capacity in the grid of the second tube of 100 $\mu\mu\text{f}$, 500 $\mu\mu\text{f}$, 5000 $\mu\mu\text{f}$, and 1.0 μf .

Test 7. Effect of the Grid Leak Resistance of the Second Tube on Amplification.—With all other conditions as in Test 3, measure the sensitiveness of the two tubes for values of the leak resistance *M* (see Fig. 19) of infinity, 2 megohms, 50,000 ohms, and zero.

Test 8. Effect of Low Plate Voltage or Low Filament Current upon Amplification.—With all other conditions as in Test 3, measure the sensitiveness of the two tubes with plate voltage about 75 per cent of normal and normal filament current; also with normal plate voltage and reduced filament current.

Test 9. Connections of a Low-frequency Amplifier with Transformer Repeater.—Make connections as in Fig. 19. Note that the rectifying

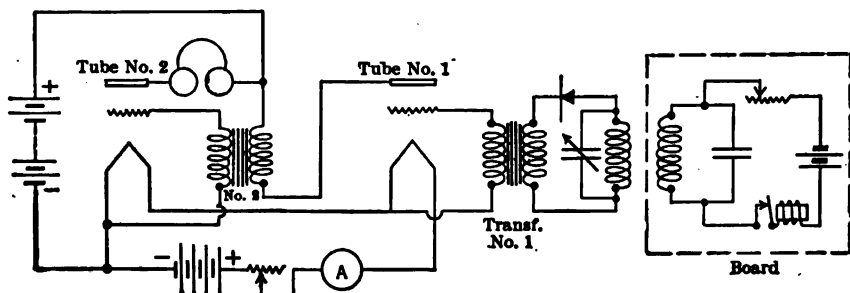

FIG. 19.

will, in this case, be done by the crystal and the amplifying by the step-up transformers and by the tubes.

Test 10. Sensitiveness of the Low-frequency Amplifier with Transformer Repeater.—Use normal filament current and plate voltage. Disconnect the primary of transformer 1, and in its place connect the phones; measure the sensitiveness of the crystal detector alone. Reconnect the primary of transformer 1, and connect the phones in place of the primary of transformer 2; measure the sensitiveness of the combination of crystal detector, transformer 1, tube 1. Again reconnect the primary of transformer 2, and connect the phones in the plate circuit of the second tube; measure the sensitiveness of the combination of crystal detector and two-stage amplifier.

NOTE: In the foregoing tests the relative sensitiveness of the various arrangements may be obtained by shunting the telephones, instead of by separating *P* and *S*; the shunt used should be of the "constant impedance" type.

QUESTIONS

1. In the diagram of Fig. 1, what is the object of the following?
 - (a) The condenser and leak resistance in the grid circuit of the first tube.
 - (b) The inductance (*G*) in the plate circuit of the first tube.
 - (c) The condenser (*C'*) in the plate of the first tube.
 - (d) The condenser (*K*) and leak resistance (*M*) in the grid of the second tube.
2. From your results of Test 4, what is the effect upon amplification of a low repeating inductance? From the results of Tests 3 and 5, how does resistance repeating compare with inductance repeating?
3. From the results of Tests 6 and 7, what are the best values of the grid condenser and grid leak resistance for the second tube?
4. From your results, how does the two-tube low-frequency amplifier with transformer repeater (Test 10) compare with the two-tube detector and low-frequency amplifier with inductance repeater?

EXPERIMENT NO. 14

Object

Study of the radio-telephone transmitter and receiver, utilizing equipment giving a range of transmission of 20 to 30 miles. The apparatus is small, of light weight, and readily portable, and has found a wide application for establishing communication in military aeronautics. Investigation of the effect of improper adjustment of the voltage of the grid of the modulating tube and of the modulating inductance.

Apparatus

1. *The Receiver*.—The receiver consists of a detecting and amplifying tube connected as shown in Fig. 20. This circuit is identical to that illustrated in Fig. 18, Experiment 13, and the apparatus required is as previously specified. The D. P. D. T. switch is omitted, or may be considered permanently thrown to the right (for amplifying action) in Fig. 18. The several capacities and grid leaks should have approximately the values indicated in the diagram.

2. *The Transmitter*.—The oscillating tube generator and its associated circuit is identical to that studied in Experiment 10, and much of the equipment specified in that experiment may be utilized. For the modulator element the following additional apparatus is required and used as indicated in Fig. 21.

Vacuum tube and receptacle (similar to the oscillator, as specified in Experiment 10).

Ordinary telephone transmitter.

Dry cells for telephone transmitter local circuit (five No 6 dry cells should give satisfactory results).

S. P. S. T. switch for transmitter circuit.

Step-up audio-frequency transformer for coupling transmitter circuit to modulator grid circuit. (This transformer measures about $3 \times 3 \times 2\frac{1}{2}$ inches and is of the closed iron core type. The inductance of the primary and secondary windings would be about .04 and 160 henries respectively, the resistance of the primary is 2 ohms while the turn ratio is approximately 60.)

Grid battery for modulator tube (about 40 volts).

“Modulating” inductance. (This is a high inductance having between 1 and 2 henries. The coil is about $2\frac{1}{2}$ inches high and $1\frac{1}{2}$ inches in diameter, has an iron core and is assembled within a surrounding soft iron shield. The d.c. resistance will be about 90 ohms.)

Low inductance. (The inductance may be any value which may be available as long as it is considerably less than the preceding inductance which represents the “normal” value.)

Antennæ for transmitter and receiver. (These are easily made, each consisting of 20 or 30 feet of wire well insulated and supported from the ceiling of the laboratory, above the apparatus. The “lead in” wire may consist simply of a voltmeter lead clipped onto this horizontal wire and properly connected to the circuit beneath.)

Operation

Before proceeding with the tests indicated below, the student should review thoroughly the theory of action of the above circuits, as described in Chapters VIII and XI.

of the wave-length contact and of the condenser in multiple with the antenna (C_1). Now talk into the telephone transmitter with your lips about 1 inch from the mouth of the transmitter, while the receiving operator endeavors to receive the speech by adjusting the variable condenser so as to "tune in" with the transmitting set. The manipulation of the two circuits to secure best results is not simple, but the adjustments should be persevered in until the best transmission of speech of which these circuits are capable is obtained. Be sure that the circuit constants permit the two circuits to be "tuned."

Test 3. Transmission of Speech under Abnormal Conditions of Potential of the Modulating Tube Grid.—Repeat Test 2 after adjusting the potential of the grid of the modulating tube to -4 volts. Note the quality of the transmission.

Test 4. Transmission of Speech with Too Low a Modulating Inductance.—Repeat Test 2 after substituting for the modulating inductance an inductance of very low value. Note the quality of the transmission.

QUESTIONS

1. In the diagram of Fig. 21 what is the purpose of the iron-cored inductance in series with the plate battery?
2. Why must the potential of the grid of the modulating tube be adjusted to a certain value for correct transmission of speech?
3. What was the quality of the transmission in Test 3, and why?
4. What was the quality of the transmission in Test 4, and why?

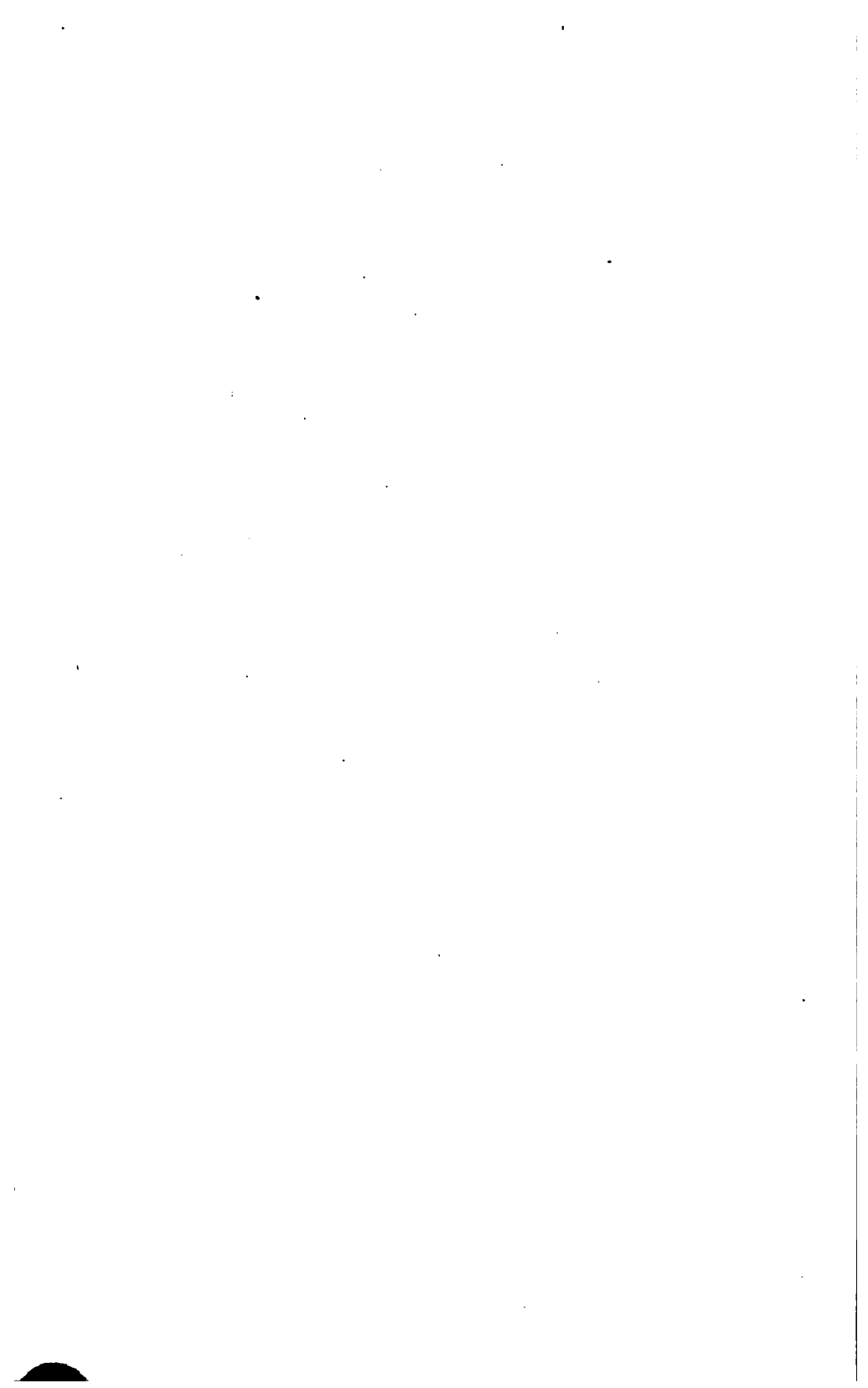

INDEX

A

	PAGE
Adjustment of oscillating detectors, peculiarities of	522
Aerial	694
Alexanderson alternator, construction and action of	594
Alexanderson's barrage receiver	688
scheme of modulation	689
Alternating current supply for the plate of a tube	529
effective value of	17
wave-shape of	17
Alternator, armature reaction of	291
high frequency for continuous-wave telegraphy	593
inductor type	289
internal impedance of	290
used for spark transmitter, action of	287
use of consequent poles in construction of	290
Amplification, distortionless, of a tube, conditions for	572
Amplifying factor of vacuum tube, experimental determination of	898
Ampere-turns	18
Amplifier, characteristics of three-electrode tube	570
classification of	824-829
connections of, for reception of damped and undamped waves	841
effect of R and L in plate circuit on action of	827-829
fields of use of radio and audio frequency types	859
inductance repeating	857
low-frequency, experimental study of	913
resistance repeating	849
stability of	870
test for quality of	577
transformer repeating	830
tube characteristics for different stages	863
tube noises in operation of	875
Amplifiers, arrangement of apparatus in	876
Amplifying power of a tube as affected by grid potential and plate circuit voltage	575
average potential of grid	574
measurement of	417
Amplitude of vacuum tube oscillations in the steady state	495
Antenna, coil, as directional radiator	711
receiver	722
constants, experimental determination of	891
"loading"	760

	PAGE
Antenna, natural wave-length of.....	751
pulse excitation of an.....	780
radiation, law of.....	730
reactance.....	757
receiving, current in.....	738
resistance.....	140, 746
setting up steady state in.....	776
Antennæ, comparative merits of different types of.....	743
distribution of current and voltage in.....	755, 760, 763
effective height of.....	716
for aeroplanes and airships.....	723
underwater.....	726
ground.....	729
simple, mechanism of radiation by means of.....	694
various types of.....	713
Arc generator or converter (Poulsen) construction of.....	589
Poulsen, theory and action of.....	580
resistance of.....	136
Armstrong, E. H., type of high frequency amplifier due to.....	860
amplification measurements by.....	518
Attenuation of propagated waves.....	196
Audio circuit of spark transmitter, analysis of action of.....	301
Austin, L. W., formula for range of radio-signal transmission.....	357
Austin's formula, analysis of.....	200
for receiving antenna current.....	196
Autodyne method of reception of continuous-wave signals.....	483, 514, 635
wave-meter.....	795

B

"Balancing out" schemes for simultaneous transmission and reception.....	687
Baldwin receiver, construction and action of.....	342
Barrage receiver.....	688, 690
Battery, polarizing, function of, with crystal rectifiers.....	343
Beat frequency, control of, in reception of continuous wave signals, using hetero-	
dyne method.....	638
in coupled circuits.....	246
receiver of continuous wave signals.....	634
Bellini and Tosi goniometer.....	767
Bridge for high-frequency measurements.....	428
Buzzer wave generator, use of.....	882

C

Capacity.....	29
electrostatic, general discussion of.....	161
of conducting, isolated sphere in air.....	162
two flat circular parallel plates in air.....	162
single vertical wire in space.....	162
horizontal wire, earth as other plate.....	162

	PAGE
Capacity of two horizontal overhead wires with respect to each other	164
wire antenna	164
a multi-plate condenser	165
internal, of a two-layer solenoid	171
multiple-layer coil	175
mutual, of two horizontal wires	163
required in closed circuit of spark transmitter, calculation of	299
specific inductive	31
Carrier frequency for radio-telephony	649
values of, for radio-telephony	653
Chaffee, E. L., quenched spark gap of	317
Charged body	2
Charges, bound and free	6
induced	6, 7
positive and negative, difference between	8
Child's formula for plate current in a two-electrode vacuum tube	377
Circuits having resistance and iron-core inductance	53
with distributed capacity and inductance, characteristics of	107
Coil antenna	714, 720, 725
as directional radiator and receiver	711, 722
for submarines	727
Condenser, bridging, application of	349
charge and discharge of	37
charging of	29
discharge, oscillatory, frequency of	212
through R and L , criterion for oscillations	211
effect of condenser leakage on	210
theory of	202
equivalent series or shunt resistance of	168
grid, in connection with use of vacuum tube in self-heterodyne circuit	643
losses occurring in	166
phase difference of	171
special form of, for wave-meter	792
variable, forms of	165
Condensers, construction of, for use in spark transmitters	297
power, characteristics of	169
Conductor, constitution of	364
Conductors	11
Consequent poles, use of, in radio alternator	290
Continuous-wave generators, efficiency of	619
forms of	580
receivers, action of	631
chopper	631
Goldschmidt tone wheel	632
oscillating vacuum tube	634
rotating plate condenser	634
tikker	634
signals, reception of	629
telegraphy, advantages of	188, 578
use of radiophone transmitting set for	627
transmitters, methods of signaling with	620

	PAGE
Counterpoise.....	694, 745
Coupled circuits, amplitude relations in (Chaffee, E. L.).....	230
analysis of oscillations in.....	226
determination of the two frequencies of oscillation.....	227
form of current in, if primary circuit is opened at the right time.....	247
formula for damping factors and decrements of current in.....	237
wave-length of oscillations.....	231
frequency of beats in.....	246
general case of three.....	229
oscillatory discharge in one circuit and non-oscillatory discharge in the other.....	249
possibility of no beats without quenching gap.....	246
shape and frequency of actual current in.....	238
vector representation of current in.....	242
oscillatory circuits, mechanical analogue of.....	223
pendulums, analysis of motion of.....	225
Coupling, capacitive.....	80, 84, 279
coefficient of.....	27, 79
conductive.....	279
direct.....	81
inductive.....	80
effect of variation of, in tuned circuits.....	103
of grid and plate circuits of an oscillating tube by capacity.....	503
a vacuum tube by capacity, critical value of, for oscillations.....	506
input and output circuits of a vacuum tube, critical value of, for oscillations.....	492
test for detecting oscillating condition of tubes.....	520, 522
various kinds of.....	79
Critical coupling of oscillating tube as affected by condenser in series with grid.....	518
Crystal rectifiers, characteristics of.....	343
laboratory investigation of.....	882
Current, continuous and alternating.....	14
direction of flow of.....	11
distribution in conductor carrying high-frequency current.....	113
electric, nature of.....	8
in a circuit containing resistance and a condenser in series.....	57
inductance and capacity in series.....	58
with resistance only.....	32, 42
an inductive circuit.....	32, 45
a condenser.....	55
coil receiving antenna.....	740
parallel circuits.....	66
simple receiving antenna.....	738
vs. frequency in an inductive circuit.....	49
inductively-coupled circuits.....	89
Currents, decaying, effect of, on neighboring circuits.....	35
in a parallel resonant circuit, oscillogram of.....	75

D

	PAGE
Damped wave, current, voltage and energy in	215
train, effective value of current in	221
Damping coefficient, definition of	214
Decrement	62
effect of, on quality of received speech in radio-telephony	678
measurement of, with wavemeter	801
Decremeter, construction and uses of (Kolster)	809
Detecting efficiency of three-electrode tube, measurement of	465
tube requirements	465
Detection of damped waves by means of regenerative tube circuit	525, 526
radio signals, visual, audible	336
undamped waves by means of oscillating vacuum tube with no grid condenser	483, 514
undamped waves by means of oscillating vacuum tube with grid condenser	486
undamped waves by means of an oscillating tube, analysis of	514
Detector action of three-electrode tube with grid condenser, analysis of	455
illustrated by oscillograms	462
of three-electrode tube with grid condenser as affected by fre- quency and decrement of signal	461
vacuum tube type	350
Detectors, action of	338
Direction finders	766
elimination of "180° uncertainty" in	772
incomplete extinction of signals in	775
reliability of	775
Distance, transmission of radio telegraphic signals	357
Dynatron	534

E

Effect of high and low grid excitation upon the form of E_p and I_p of a separately excited power tube	541
high and low load resistance upon the form of E_p and I_p of a separately excited power tube	543
the local oscillations of a tube detector of undamped waves upon strength of signals	516
Efficiency, calculated, of a separately excited power tube for various forms of plate current	552
calculated, of a separately excited power tube for various plate voltages	552
measured, of a separately excited power tube	554
of a three-electrode tube as a detector, analysis of	446
Electric fields	3
represented by lines	4
Electricity, nature of	1
Electro-magnetic waves, discussion of	181, 702
Electro-motive force	10
induced	23

	PAGE
Electron bombardment in vacuum tubes.....	390
emission affected by condition of hot surface.....	367
from a conductor.....	364
filament <i>vs.</i> filament current.....	379
power required for.....	371
stream as constituting an electric current.....	698
Electrons.....	1
current due to velocity of.....	369
distribution of, near surface of a hot metal.....	368
emitted from a hot body, theoretical prediction of number of.....	364
number of, removable from an atom.....	3
velocity of emission of, from a hot metal.....	368
Elimination of undesired frequencies in oscillating tube circuits.....	512
Energy distribution curve of spark transmitter.....	325, 331, 799
undamped wave transmitter.....	800
of radiated electric and magnetic fields.....	182, 696
water particles in water waves.....	181
stored in a charged condenser.....	31
magnetic field.....	26
supply of spark transmitter, forms of.....	281
Evacuation of a vacuum tube.....	393
Excitation of spark transmitter, forms of.....	280
separate, for a group of vacuum tubes.....	532

F

Fan antenna.....	713, 718
Fence wire as receiving antenna.....	730
Field, electric, due to an antenna, intensity of.....	703, 707
electric, in motion.....	696
electric, open and closed.....	5, 699
magnetic.....	18
magnetic, due to an antenna, intensity of.....	703, 707
magnetic, in motion.....	696
magnetic, open and closed.....	698, 699
energy stored in.....	26
induction.....	182, 703
radiation.....	182, 704
radiated, at any distance from an antenna consisting of a vertical wire.....	705
a coil antenna.....	708
Fields, electric.....	3
represented by lines.....	4
Filament of a vacuum tube, unequal currents in.....	379, 403
resistance of.....	404
Filaments for vacuum tubes, tungsten and oxide coated.....	400
Filters, use of, in amplifiers.....	864
"Fleming" valve.....	372
Fluorescence in vacuum tubes with oxide coated filaments.....	392
"Freak" transmission.....	200
Frequency changers, application of rectifier elements to.....	616
types of.....	608

	PAGE
Frequency changers, types of, for tripling frequency (Joly).....	608
(Taylor).....	611
for doubling frequency (Epstein-Vallouri).....	609
(Pohl).....	610
losses of.....	613
audio.....	186
effect of upon input capacity and conductance of a tube.....	439
of oscillating tube current for capacity coupling of grid and plate circuits.....	506
an oscillating tube, constancy of.....	514
radio.....	186
transformation.....	607
tripling, use of wabbling neutral for obtaining.....	613
Finger test for detecting oscillating condition of tubes.....	520, 522

G

Gas in tungsten filament tubes, tendency of, to disappear.....	396
a vacuum tube, effect of.....	390
detection of.....	394
Generator, electric.....	16
Generators of high frequency, undamped waves, types of.....	580
use of, for power supply to amplifiers.....	870
Goldschmidt alternator, construction of.....	606
theory of action of.....	599
Goniometer, Bellini and Tosi.....	767
Grid.....	381
action of, in three-electrode tubes.....	382
condenser for three-electrode tube when used as detector of damped waves.....	451
value of, for tubes used as detectors.....	455, 461
current in well-evacuated three-electrode vacuum tube.....	399
normal potential of.....	454
potential of a three-electrode tube when acting as detector with grid condenser.....	464
free.....	402, 410
Ground antennæ.....	729

H

Harmonics, upper, effect of, in reception of continuous-wave signals, using heterodyne receiver.....	639
Harp antenna.....	713
Heating of the plate of a three-electrode tube.....	473
Heising's scheme of modulation.....	664, 665
Heterodyne reception of undamped waves.....	483, 517, 635
"Hysteresis" in vacuum tubes.....	397

I

Impedance, definition.....	47
of a branched circuit containing L and R in one branch and C and R in the other.....	68
circuit containing L , R and C in series.....	68

	PAGE
Impulse excitation of a parallel resonant circuit.....	266
oscillating circuit.....	259
Inductance, in grid and plate circuits of an oscillating tube, effect of, upon the operation of tube.....	570
mutual, of two single turns, coaxial.....	156
coaxial, circular coils of rectangular cross-section....	156
solenoids.....	157
of two overhead parallel wires, grounded, at same height from ground.	157
between two concentric coils, as one rotates.....	158
coaxial spirals.....	160
self-, discussion of.....	143
of a single straight vertical wire distant from all other conductors.	144
circular turn of round wire.....	145
-layer solenoid closely wound.....	145
flat spiral.....	147
flat square coil.....	151
toroidal coil of rectangular cross-section.....	149
circular cross-section.....	150
single-layer square coil.....	150
multi-layer coils of rectangular cross-section.....	152
two-wire antennae.....	157
variable, design of.....	153
Induction coil, action of.....	282
Inductor alternator, action of.....	287
Input circuit of a tube.....	421
capacity and conductance of, vs. plate circuit resistance....	435
conductance of, vs. filament current.....	429
plate voltage.....	430
grid potential.....	431
effective capacity of.....	434
geometrical capacity of.....	432
negative conductance of.....	437
resistance of.....	428
used as a detector, equivalent of.....	454
Insulators.....	11
disruptive strength of.....	13
effect of temperature on disruptive strength of.....	13
Interference, discussion of.....	191, 193
Interrupter action, requirements of.....	282
"hammer break" type.....	282
Interrupters for primary circuit of induction coils, types of.....	287
Ionisation, danger of, to vacuum tubes.....	392
in vacuum tubes.....	390
Iron-core coils, resistance of.....	134

K

Kenotron.....	373
Kenotrons used for rectifying alternating current for supply to plate of a vacuum tube.....	529
Kolster, F. A., decimeter, construction and uses.....	809

L

	PAGE
"L," inverted, type of antenna.....	713, 716, 718
Leak resistance for three-electrode tube when used as detector of damped waves... value of, for tube used as a detector.....	451 455
Leyden jar, use of, in spark transmitter.....	298, 299
Limitations of transmission formulae.....	744
"Loading" an antenna.....	760
Logarithmic decrement, definition of..... formula for..... graphs for three-electrode tubes.....	214 214, 215 421
Loop antenna for submarine.....	727

M

Magnetic field..... effect of iron in.....	18 19
Marconi, multi-gap generator of continuous waves.....	616
Mercury rectifier.....	372
Meters in alternating current circuits.....	44
Microphone, liquid..... transmitter.....	656 655
Miller, J. M., method for measuring μ_0 of a tube..... A.C. output resistance of a tube.....	417 426
Modulated current..... wave, analysis of.....	649 674
Modulating frequency.....	649
Modulation, analysis of..... percentage of..... requirements for..... sch mes for.....	657 660 656, 668 661
Motor, speed of, for driving radio alternator..... types of, for driving radio alternator.....	334 290
Multiple-tuned antenna.....	714, 719
Multiplex radio-telephony.....	680
Mutual induction.....	26

N

Natural period of multi-layer coils.....	177
Neutralisation schemes for simultaneous transmission and reception.....	687
Noises in oscillating tube detector circuit.....	523

O

Oscillating conditions of a tube, criteria for..... power tube circuit, laboratory study of characteristics of..... tubes in multiple..... receiving set for radio-telephony..... tube circuits of very high frequency..... receiving circuit, laboratory investigation of.....	520 903 527 677 511 908
--	--

	PAGE
Oscillating tube under conditions of oscillating current comparable in value with plate current.....	503
tube, use as a continuous wave generator.....	617
Oscillation transformer, construction of.....	318
experimental investigation of power output.....	900
with oscillating circuit in grid circuit.....	510
vacuum tube, adjustment for maximum output.....	501
as a detector of undamped waves.....	483
circuits, analysis of.....	487
conditions for maximum output of.....	471, 497
efficiency of.....	468, 471
elementary analysis of.....	469
excitation of.....	469
output of.....	471
uses of.....	468
current and power of, vs. exciting grid voltage...	490
conditions necessary for self-excitation.....	478
Oscillations of a vacuum tube, effect of, on grid and plate currents.....	500
tube, effect of, upon plate current.....	519
vacuum tube at other than desired frequency.....	502, 512
stability of.....	498
starting and stopping.....	499
types of (of arc generators).....	586
Oscillograph.....	33
Oscillatory circuit, current and voltage relations in.....	213
excited by a damped sine wave, analysis of.....	268
being connected to a line of alternating e.m.f., theory of.....	252
continuous voltage, theory of.....	249
damped sine waves, resonance curve of.....	227
energy stored in inductance, theory of.....	250
pulse, analysis of.....	259
condition of a vacuum tube, prediction of, by placing total resistance equal to zero.....	492
currents of a spark transmitter, discussion of.....	321
discharge, frequency and damping of, as affected by neighboring circuits.....	222
through a spark gap.....	218
Output circuit of a tube.....	421
impedance of a tube.....	423
resistance of a tube.....	423
A.C., measurement of.....	424
P	
Phase.....	42
of the grid voltage of a self-excited tube, possibility of variation of.....	562
relation of electric and magnetic fields in electro-magnetic radiation....	702, 705
relations, effect of, on the possible power output of vacuum tube generator..	476
of voltages and current in a vacuum-tube generator.....	474, 493
Pliodynatron.....	534

	PAGE
Potential difference.....	11
gradient between plate and filament of a two-electrode vacuum tube....	377
Poulsen arc, theory and action of.....	580
Power, amount sent out and received.....	198
factor.....	48
in a circuit excited by pulsating current.....	40
continuous current circuit.....	38
an inductive circuit.....	47
a resistance circuit.....	43
transmitted and received.....	198
used in the plate of a three-electrode tube.....	473
Production of current in antenna, methods for.....	711
Protective equipment of spark transmitter.....	278
Pulse excitation of oscillating circuit.....	259

Q

Quality of speech received by radio-telephony as affected by decrement.....	678
Quenched gap, construction of.....	314
theory of action of.....	247

R

Radiation.....	182
mechanism of, by means of simple antenna.....	694
of light from a hot filament compared to radiation from an antenna....	734
power from an antenna, law of.....	730
a coil antenna, law of.....	735
resistance.....	737
Radio-compass service or ships.....	771
Radiophone sets.....	684, 692
Radiophone transmitting set, use of, for undamped wave telegraphy.....	627
Radio-telephony, fundamental idea.....	189
Radio-telephone transmitter and receiver, experimental study of.....	916
Reactance, definition.....	47
Receiving circuits ..	190
adjustment of, for damped wave signals.....	350, 882
for damped wave signals.....	340
station, essential elements of a.....	189, 336
Reception of undamped waves by means of oscillating tubes.....	483, 514
Rectification by three-electrode tube without grid condenser, as shown by oscillograms.....	445
Rectifying detectors, action of.....	338
Resistance.....	14, 21, 111
and reactance of the primary of an inductively-coupled circuit as affected by secondary.....	93
effective.....	40
high frequency, general concept of.....	111
laboratory measurement of.....	906
of antenna.....	746
coils, effect of neighboring circuits on.....	133

	PAGE
Resistance of iron-core coils.....	134
spark and arc.....	136
the circuits of a three-electrode tube and its variation.....	421
Resonance.....	40
curves for coupled circuits.....	99
form of.....	101
curve of an oscillatory circuit excited by damped sine waves.....	272
in a circuit to which another is magnetically coupled.....	85
simple series circuit, laboratory investigation of.....	880
circuits with capacitive coupling.....	105
series, with varying capacity.....	62
transformer, definition of.....	296
Resonant adjustment of the audio circuit of a spark transmitter.....	295
circuit, effect of periodic disturbances in a.....	257
frequencies in coupled circuits.....	94
frequency of parallel circuits.....	78
multiple circuit.....	73
curves of reactances and resistance for.....	76
Richardson's formula for electron emission.....	385

S

Saturation current.....	367, 373
Selectivity, general discussion of.....	191
Self-heterodyne method of reception of continuous-wave signals.....	635
Self-induction, coefficient of.....	25
of a coil as affected by presence of a short-circuited neighboring coil.....	28
Short-wave condenser, function of.....	278
Shunting condenser used with induction coil, action of.....	283
Signal, day and night variation in strength of.....	197
seasonal variation in strength of.....	198
selection of.....	350
Signaling with high frequency, continuous-wave generators, methods of.....	620
Simultaneous radiophone transmission and reception.....	686
sending and receiving, essential elements required for.....	192
Skid-fin antenna for aeroplanes.....	724
Skin effect, analysis of.....	117
discussion of.....	113
elimination of.....	122
in coils.....	125
Space charge in vacuum tubes.....	376, 380
Spark gap, care of.....	333
Chaffee type.....	317
classification of, for spark transmitter.....	309
non-synchronous type.....	313
open type, operating conditions of.....	309
quenched.....	247-314
synchronous rotating type, description and operation of.....	311
resistance of.....	136
telegraphy, definition of.....	187
transmitter, adjustment of.....	328

	PAGE
Spark transmitter, capacity and inductance required in closed and open circuits . . .	834
description of	275
experimental investigation of	887
Specific inductive capacity, table of values	167
Static	193
Steady state in an antenna, setting up of	776
Stone, J. S., equation for spark-gap resistance	219
Strays, classification of	193
elimination of	194

T

"T" antenna	713, 716, 725
Time constant of an inductive circuit	33
a condenser circuit	38
Telephone receivers, construction and action of	340
impedance of	839
Telephony, radio multiplex	680
current in transmitting antenna	648
receiver	652
receiving antenna	650
field of use	646
principle of operation of transmitter	647
receiver	649
power required to cover distances	683
receiving system for	673
sources of power for	654
transmission of speech	651
Temp rature, maximum safe, for tungsten filaments	371
Transformer, "open core," description of	296
power for spark transmitter	292
Transformers, construction of, for low-frequency amplifiers	839
Transmission, distance of radio signal	357
formule, limitations of	744
Transient conditions in a circuit consisting of L , R and C in series, analysis of	252
current in an inductive circuit	49
a circuit consisting of resistance and a condenser in series	58
on switching a resistance circuit to an A.C. line	45
phenomena in audio circuit of spark transmitter, analysis of	304
Transmitter for radio-telephony, best resistance for	660
Transmitters for radio-telephony	654
Tree as receiving antenna	730
Tube, three-electrode	381
as detector of damped waves	440
a source of alternating current	467
power converter, detailed study of, when self-excited	561
separately excited	539
characteristics of, with positive common junction and with negative common junction	459
two-electrode as voltage regulator for a variable speed generator	373
characteristic curves of	373

	PAGE
Tube, vacuum, two-electrode.....	371
Tubes, limits of operation of.....	389
three-electrode, characteristic curves of.....	401
for high power telephone sets.....	669
in radio-telephony.....	662
fields of, use of.....	387
hydraulic model of.....	385
potential distribution in.....	382
relations between currents and potentials in.....	415
resistance of circuits of, and its variation.....	421
various types of.....	388
with small amount of gas, characteristic curves of.....	397
vacuum, special forms of.....	534
"Tungar" rectifier.....	372

U

Umbrella antenna.....	713
Unequal currents in the filament of a vacuum tube.....	379, 403
Unilateral connection of wavemeter.....	786
Unipotential emitting surface for a vacuum tube.....	379
Units of electrical quantities.....	20

V

Vacuum tube, experimental determination of amplifying factor and internal plate circuit resistance.....	898
investigation of characteristic curves of.....	894
study of its characteristics when used as a detector of damped waves.....	895
generator, measurement of power output of.....	900
transmitting sets, arrangement of apparatus in.....	645
use as a detector.....	350
Voltage amplification factor of a three-electrode tube.....	384, 417
determination of.....	417

W

Wattmeter.....	49
Wave-length.....	183
natural, of antenna.....	751
of electro-magnetic radiations.....	213
Wave-lengths, range of, for radio communication.....	187
used in spark telegraphy.....	356
Wave-meter, autodyne type.....	795
devices and schemes for indicating resonance.....	783
condenser, special form of.....	792
crystal detector and phones.....	785
hot-wire ammeter.....	784
incandescent lamp.....	791
neon tube.....	790
crystal detector and galvanometer.....	790
thermo-couple and galvanometer.....	788

	PAGE
Wave-meter, experiment on uses of the.....	884
how to improvise a.....	821
principle and construction of.....	781
use of, to determine decrement.....	801
mutual inductance and coefficient of coupling....	819
measure antenna constants.....	815
inductance and capacity.....	814
wave-length and energy distribution curves....	796-798
Wave motion, discussion of.....	179
propagation, equation for.....	183
velocity of.....	184
Waves, attenuation of.....	196
damped.....	186
electromagnetic, discussion of.....	181, 702
transmission of, in water.....	728
number of, in a train, formula for.....	220
stationary, on antenna.....	756
undamped.....	186
various types of, used in radio communication.....	185
water.....	179
Wave-shape of alternating currents.....	16
Wave-trains.....	186

2



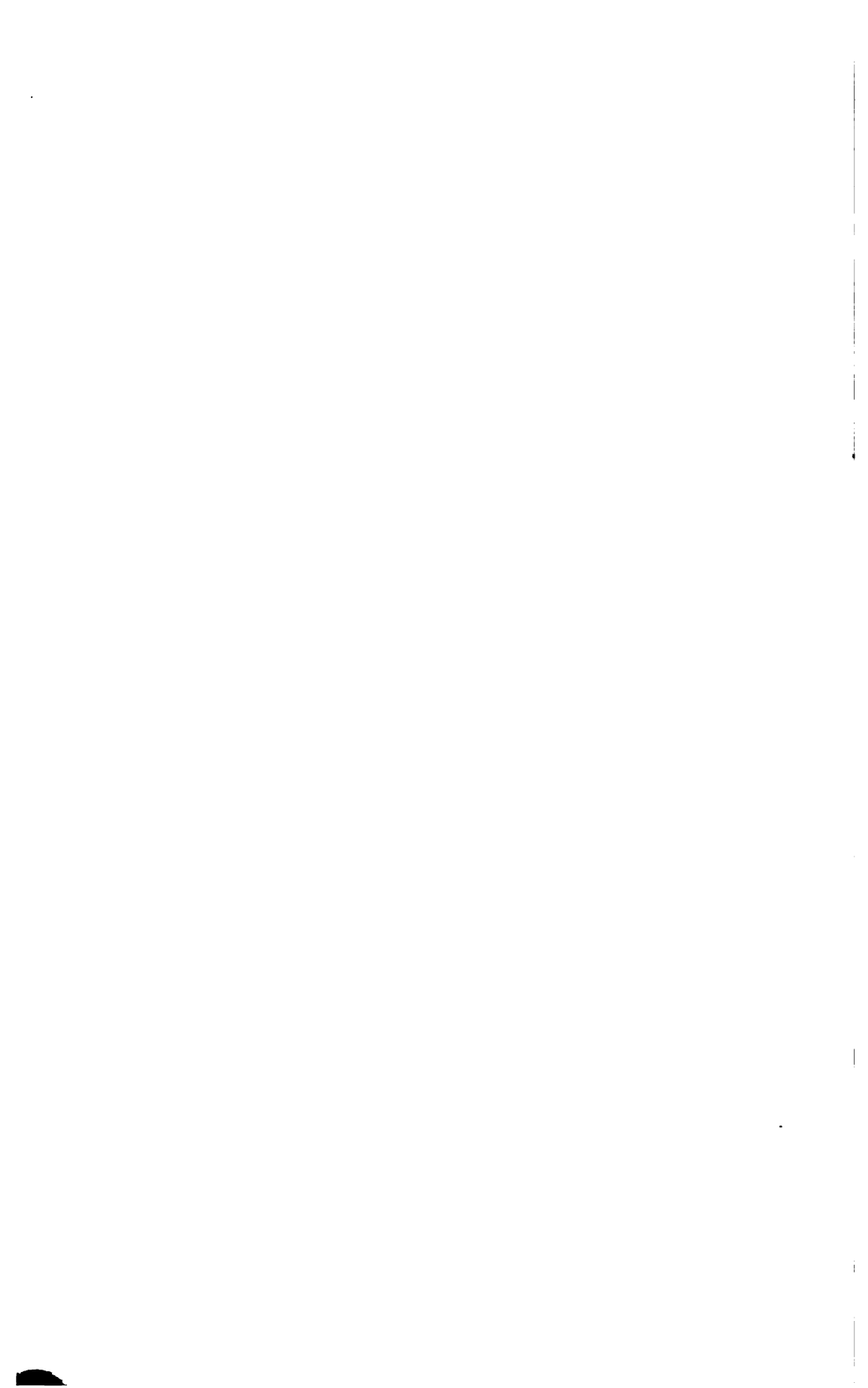

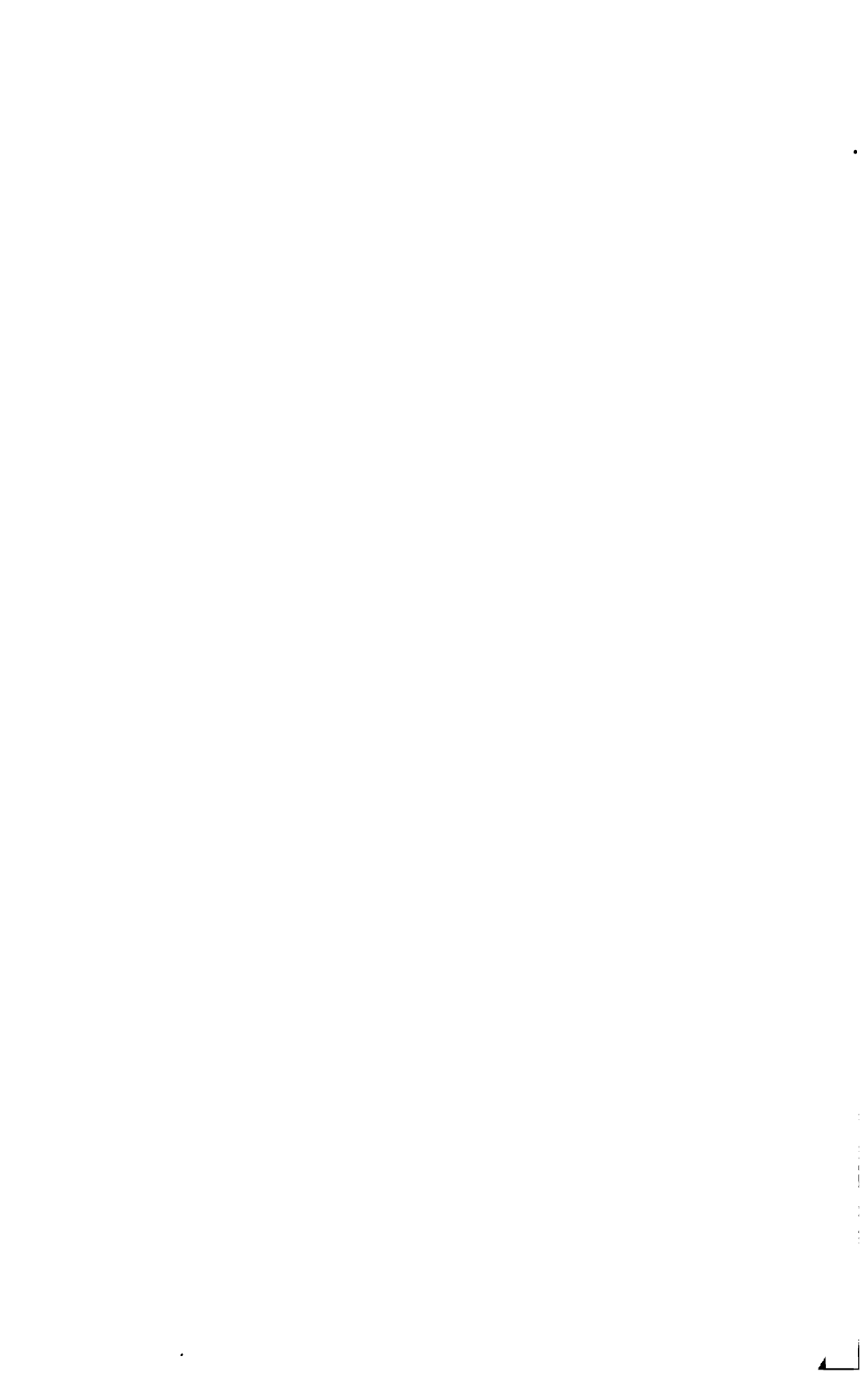

Book should be re
y on or before the
slow.
f five cents a day
g it beyond th

on promptly



3 2044 044 466 548



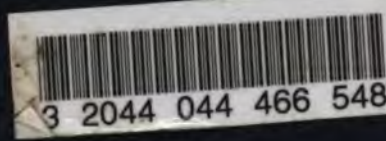

3 2044 044 466 548